

DINING SIDE CHAIR

ASSEMBLY INSTRUCTIONS



ASSEMBLY TIPS:

1. Remove hardware from box and sort by size.
2. Please check to see that all hardware and parts are present prior to start of assembly.
3. Please follow attached instructions in the same sequence as numbered to assure fast & easy assembly.



Warning!



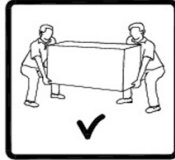

1. Don't attempt to repair or modify parts that are broken or defective. Please contact the store immediately.
2. This product is for home use only and not intended for commercial establishments.





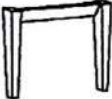

ASSEMBLY TIME

15 MINUTES

PARTS IDENTIFICATION

	PART NAME	FIGURE	QTY
A	BACK FRAME		1PC
B	FRONT LEG FRAME		1PC
C	LEFT SIDE RAIL		1PC
D	RIGHT SIDE RAIL		1PC
E	SEAT CUSHION		1PC

HARDWARE IDENTIFICATION

	HARDWARE NAME	FIGURE	QTY
1	ALLEN WRENCH (4MM - BLK)		1PC
2	BOLT (Φ4/17" x 2" - RBW)		6PCS
3	NYLON WASHER (3/5" x 3/5" - BLK)		6PCS
4	FLAT HEAD SCREW (Φ3/19" x 1" - RBW)		4PCS

NOTE : QUANTITIES SHOWN ARE FOR ONE CHAIR

**NOTE : PHILLIPS HEAD SCREW DRIVER IS REQUIRED IN THE ASSEMBLY PROCESS;
HOWEVER, MANUFACTURER DOES NOT PROVIDE THIS ITEM.**

ASSEMBLY INSTRUCTIONS

STEP 1

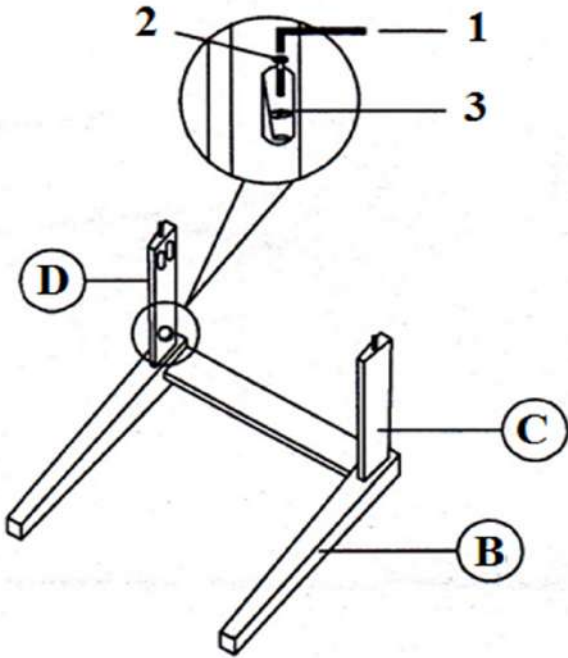

STEP 2

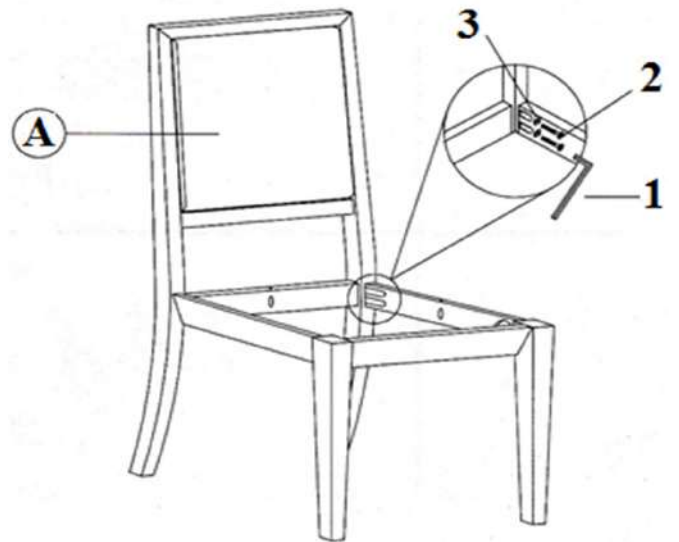

STEP 3

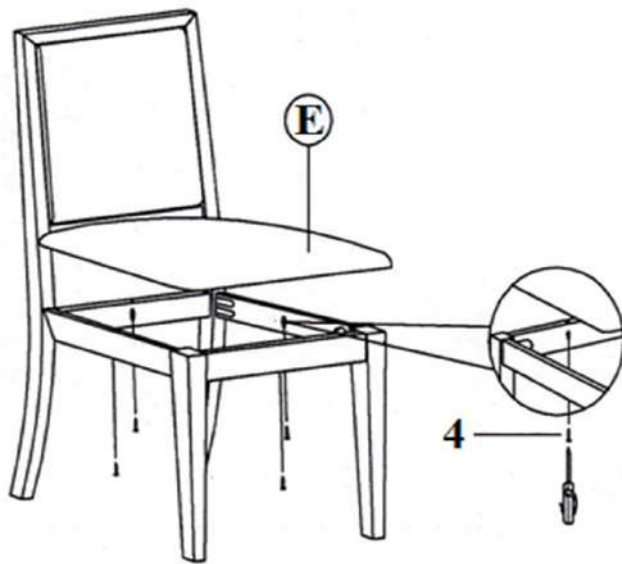

STEP 4 COMPLETE

