

ASSEMBLY INSTRUCTIONS

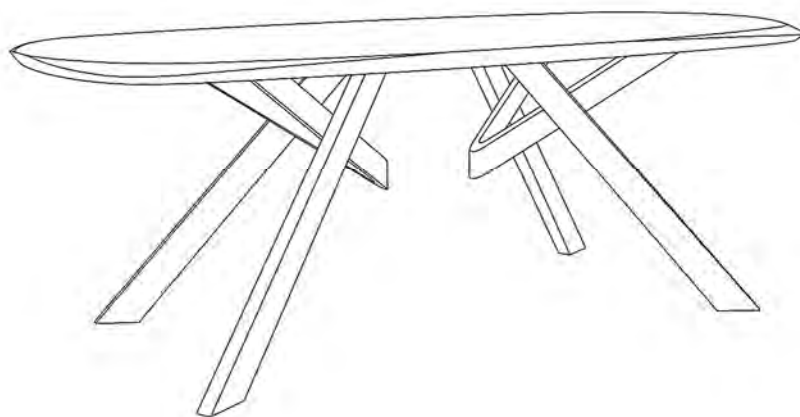

TOOLS REQUIRED

(Included)
Allen Wrench



2 - People

ASSEMBLY RATING



EASY ————— DIFFICULT

The Assembly Rating is a 5-point system showing the level of effort needed to assemble a specific product.



CHECK BEFORE STARTING

Are you missing anything?

Double-check all parts, hardware and accessories listed are all accounted for.

Check out our Quick Tips!

We recommend reviewing the pre-assembly handouts. Even experts need a refresher now and then!

Should we send any replacements?

Are there any irregularities or flaws in the parts? We can send replacements!

Prep Time!

Please review the assembly instructions and all diagrams prior to assembling.

PRE ASSEMBLY INTRODUCTION

We understand building ready-to-assemble furniture can be a challenging experience for some. To help avoid confusion, we have provided some helpful tips that may speed up the process.



Teamwork

ALWAYS have at least two people to help with transporting and assembling the product to avoid potential injury and/or damage.



Suitable Location

Assembling near the area of the intended location is highly recommended.



Sufficient Space

Make sure you have enough space to move around during the assembly.



Avoid Scratches

Use cardboard, blankets or a carpeted area while assembling furniture to prevent to prevent scratches and damages.

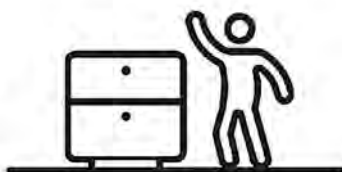

Flat Surface

Make sure the furniture rests on a flat and level surface with each leg evenly touching the floor.

ASSEMBLY AND CARE ADVICE



FAILURE TO FOLLOW THE GUIDELINES BELOW MAY RESULT IN INJURY AND/OR PROPERTY DAMAGE.



Position each part correctly and insert screws or bolts into their respective holes.

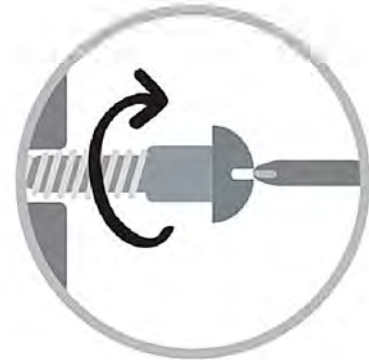

Turn clockwise to tighten and only tighten when step is completed or when instructed to do so.



Use the appropriate hand tools or power tools for assembly. Select steps, such as tightening screws and/or bolts, may require hand tools to avoid causing damage during assembly.



Save the instructions and store any supplied tools for later maintenance.



After two weeks, check and tighten any loose hardware and repeat again every six months thereafter.

IT IS THE USER'S RESPONSIBILITY TO MAINTAIN THE FURNITURE. THE HARDWARE MAY LOOSEN OVER TIME AND MAY CAUSE THE FURNITURE TO BE WOBBLY AND UNABLE TO SUPPORT ITS INTENDED WEIGHT CAPACITY. THIS MAY LEAD TO COLLAPSE AND MAY CAUSE SERIOUS INJURY.

DINING TABLE

NO. 001 002 003 004 005 006 007 008 009 010



- Please keep instructions for future reference.
- Check the quantity and irregularity of parts and hardware before you start.

PARTS

1 1pc

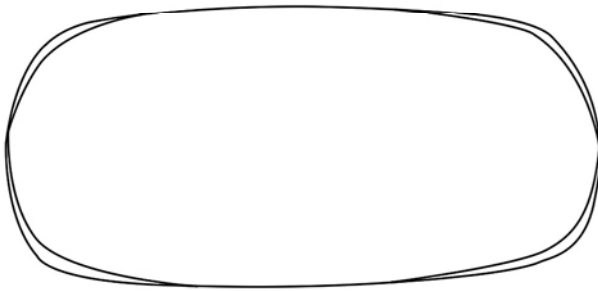
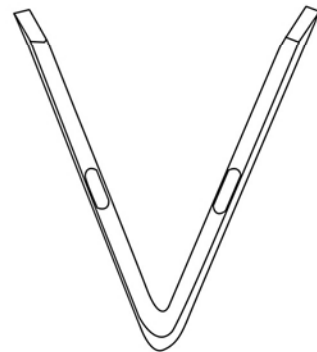

TABLE TOP

2 2pcs



V LEG SUPPORT

3 2pcs



TABLE LEG - LEFT

4 2pcs

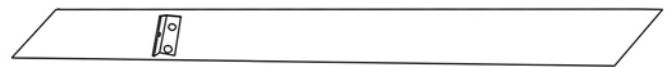
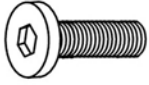

TABLE LEG - RIGHT

HARDWARE

A 4pcs



JCBC BOLT
M6 x 20MM

B 4pcs



LOCK WASHER
M6

C 4pcs



FLAT WASHER
M6

D 1pc



ALLEN KEY
M4

E 16pcs

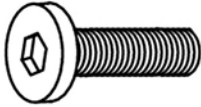

JCBB BOLT
M8 x 30MM

F 4pcs

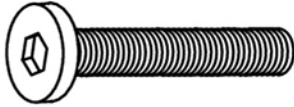

JCBB BOLT
M8 x 45MM

G 20pcs

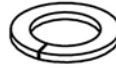

LOCK WASHER
M8

H 20pcs



FLAT WASHER
M8

I 1pc



ALLEN KEY
M5

J 4pcs

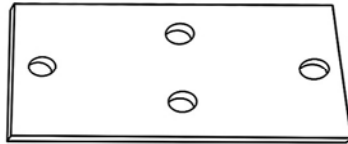

METAL PLATE

ASSEMBLY INSTRUCTIONS

1

- Part ③ x 2pcs
- Part ④ x 2pcs
- Hardware ⑤ x 8pcs
- Hardware ⑥ x 8pcs
- Hardware ⑦ x 8pcs
- Hardware ⑧ x 1pc
- Hardware ⑨ x 4pcs

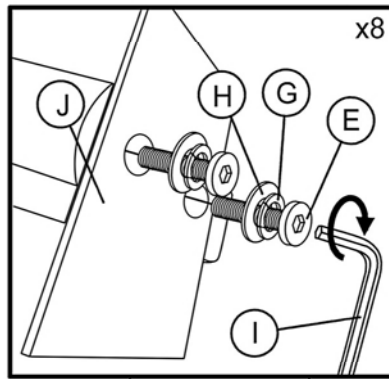

Attach the metal plate (#J) to the table leg (#3) and (#4) with allen key (#I) and by using bolt (#E) with lock washer (#G) and flat washer (#H).

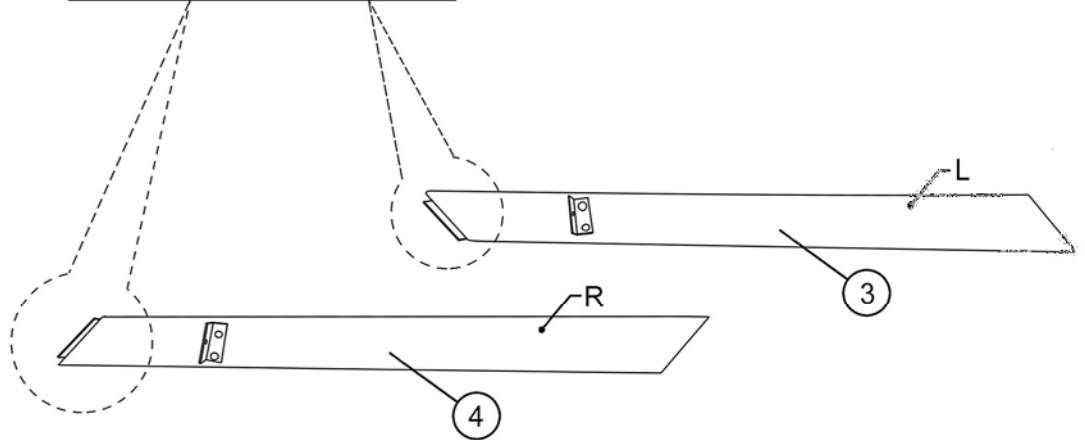

2

- Part ② x 2pcs
- Part ③ x 2pcs
- Part ④ x 2pcs
- Hardware ⑩ x 4pcs
- Hardware ⑪ x 4pcs
- Hardware ⑫ x 4pcs
- Hardware ⑬ x 1pc

Attach the v leg support (#2) at the center of the table leg (#3) and (#4) and start inserting bolts (#A) with lock washer (#B) and flat washer (#C) by using allen key (#D).

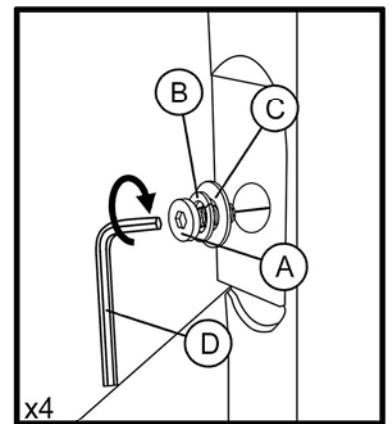
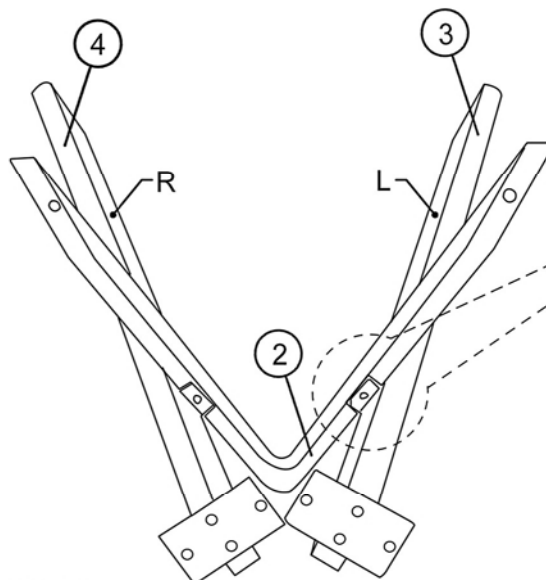

Do not tighten these JCBC Bolt.

ASSEMBLY INSTRUCTIONS

3

- Part ① x 1pc
- Hardware ⑤ x 8pcs
- Hardware ⑦ x 8pcs
- Hardware ⑧ x 8pcs
- Hardware ⑩ x 1pc

Align the metal plates to the table top (#1) and start inserting the bolts(#E) with lock washer (#G) and flat washer (#H) with allen key (#I).

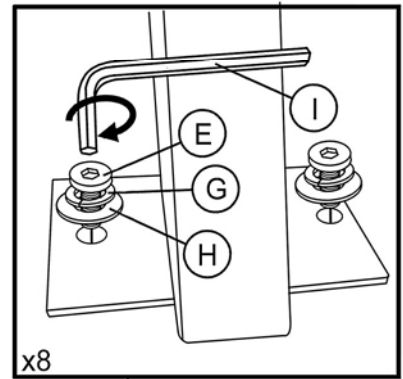
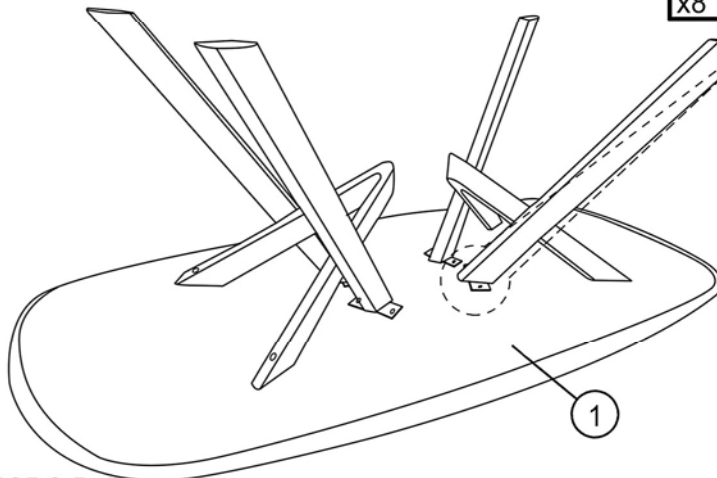

Do not tighten these JCBC Bolt.

4

- Hardware ② x 4pcs
- Hardware ③ x 4pcs
- Hardware ④ x 4pcs
- Hardware ⑥ x 1pc
- Hardware ⑤ x 8pcs
- Hardware ⑦ x 4pcs
- Hardware ⑦ x 12pcs
- Hardware ⑧ x 12pcs
- Hardware ⑩ x 1pc
- Hardware ⑪ x 4pcs

Align the v leg support (#2) to the table top (#1) and start inserting the bolts (#F) with lock washer (#G) and flat washer (#H) with allen key (#I).

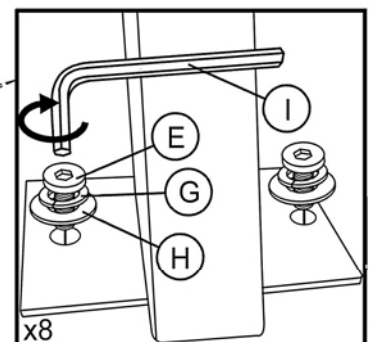
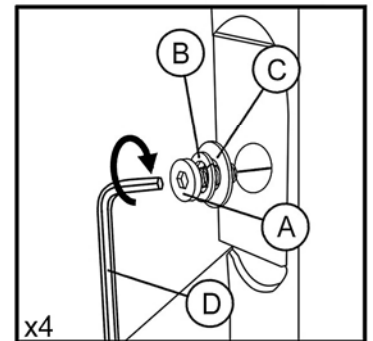
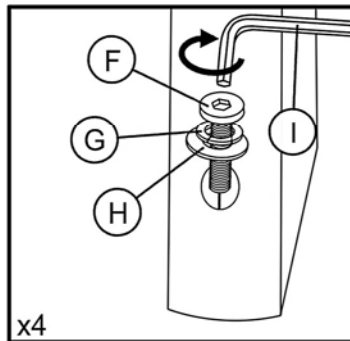
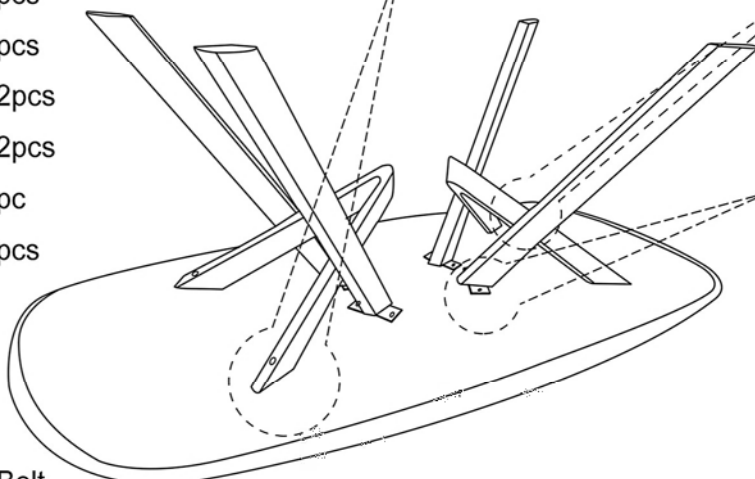

Tighten all JCBC Bolt.

ASSEMBLY INSTRUCTIONS

5

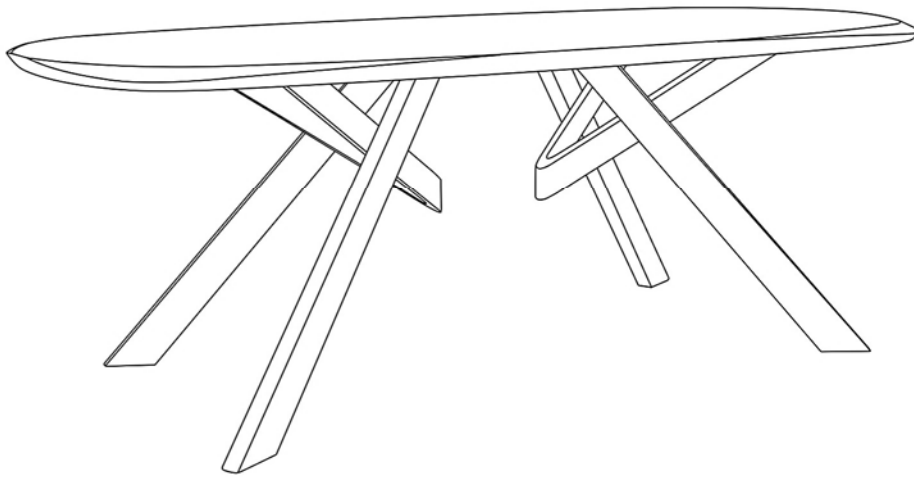

ASSEMBLY COMPLETED



Please ensure the furniture rests on an even and flat surface. If the product wobbles or feels loose, double-check all bolts and/or screws are properly tightened and secured.

✓ **Keep this handy!**
Please retain this instruction manual and any order-related information for future reference.

✓ **Lift, don't drag!**
To avoid damage to product please always LIFT the product when transporting or adjusting the placement.

This product is intended for RESIDENTIAL USE ONLY and not for commercial use.

ASSEMBLY INSTRUCTIONS



TOOLS REQUIRED



Screwdriver
(Not Included)

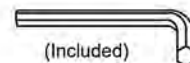

(Included)
Allen Wrench



2 - People

ASSEMBLY RATING



EASY ————— DIFFICULT

The Assembly Rating is a 5-point system showing the level of effort needed to assemble a specific product.



CHECK BEFORE STARTING

Are you missing anything?

Double-check all parts, hardware and accessories listed are all accounted for.

Check out our Quick Tips!

We recommend reviewing the pre-assembly handouts. Even experts need a refresher now and then!

Should we send any replacements?

Are there any irregularities or flaws in the parts? We can send replacements!

Prep Time!

Please review the assembly instructions and all diagrams prior to assembling.

PRE ASSEMBLY INTRODUCTION

We understand building ready-to-assemble furniture can be a challenging experience for some. To help avoid confusion, we have provided some helpful tips that may speed up the process.



Teamwork

ALWAYS have at least two people to help with transporting and assembling the product to avoid potential injury and/or damage.



Suitable Location

Assembling near the area of the intended location is highly recommended.



Sufficient Space

Make sure you have enough space to move around during the assembly.



Avoid Scratches

Use cardboard, blankets or a carpeted area while assembling furniture to prevent to prevent scratches and damages.

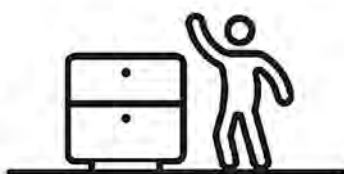

Flat Surface

Make sure the furniture rests on a flat and level surface with each leg evenly touching the floor.

ASSEMBLY AND CARE ADVICE



FAILURE TO FOLLOW THE GUIDELINES BELOW MAY RESULT IN INJURY AND/OR PROPERTY DAMAGE.



Position each part correctly and insert screws or bolts into their respective holes.

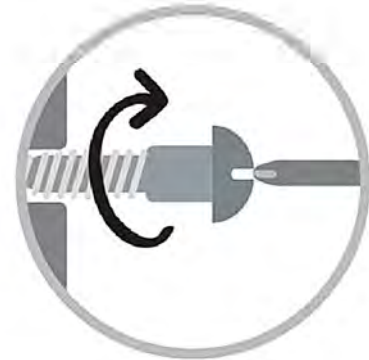

Turn clockwise to tighten and only tighten when step is completed or when instructed to do so.



Use the appropriate hand tools or power tools for assembly. Select steps, such as tightening screws and/or bolts, may require hand tools to avoid causing damage during assembly.



Save the instructions and store any supplied tools for later maintenance.



After two weeks, check and tighten any loose hardware and repeat again every six months thereafter.

IT IS THE USER'S RESPONSIBILITY TO MAINTAIN THE FURNITURE. THE HARDWARE MAY LOOSEN OVER TIME AND MAY CAUSE THE FURNITURE TO BE WOBBLY AND UNABLE TO SUPPORT ITS INTENDED WEIGHT CAPACITY. THIS MAY LEAD TO COLLAPSE AND MAY CAUSE SERIOUS INJURY.

DINING SIDE CHAIR



- Please keep instructions for future reference.
- Check the quantity and irregularity of parts and hardware before you start.

PARTS

1 1pc

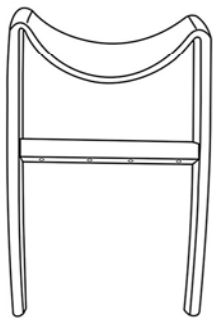

BACK PANEL

2 1pc



SIDE WOOD - LEFT

3 1pc



SIDE WOOD - RIGHT

4 1pc

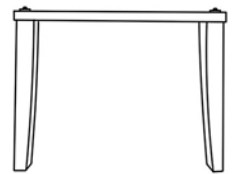

FRONT LEG

5 1pc

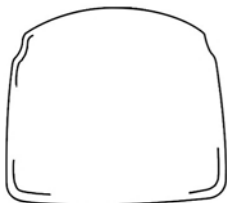

CUSHION SEAT

HARDWARE

A 6pcs

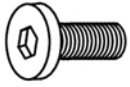

JCBC BOLT
M6 x 35MM

B 4pcs



JCBC BOLT
M6 x 50MM

C 10pcs



LOCK WASHER
M6

D 10pcs



FLAT WASHER
M6

E 6pcs



CSK SCREW
M4 x 32MM

F 1pc



ALLEN KEY
M4

ASSEMBLY INSTRUCTIONS

1

- Part (4) x 1pc
- Part (5) x 1pc
- Hardware (A) x 6pcs
- Hardware (C) x 6pcs
- Hardware (D) x 6pcs
- Hardware (F) x 6pcs

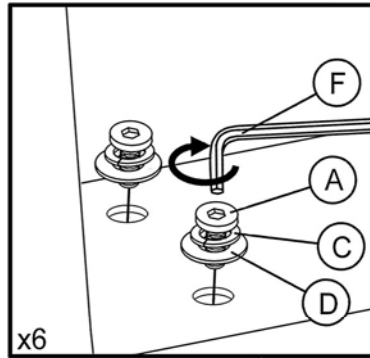

Align front leg (#4) to the cushion seat (#5) and with allen key (#F) secure using bolt (#A) with lock washer (#C) and flat washer (#D).

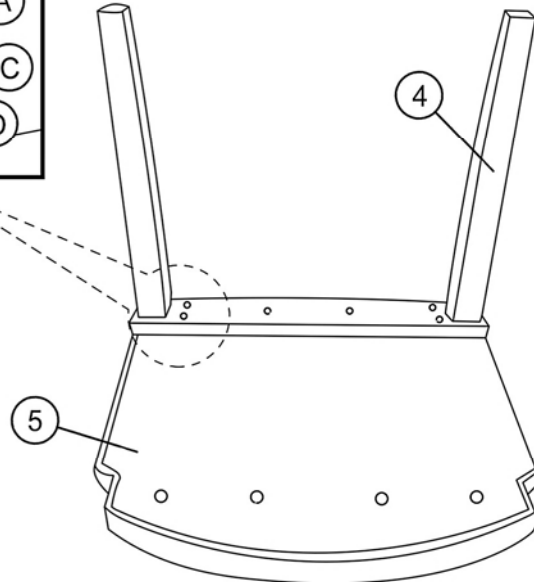

2

- Part (1) x 1pc
- Hardware (B) x 4pcs
- Hardware (C) x 4pcs
- Hardware (D) x 4pcs
- Hardware (F) x 1pc

Align the back panel (#1) to the seat cushion (#5) and by using allen key (#F) secure by using bolt (#B) with lock washer (#C) and flat washer (#D).

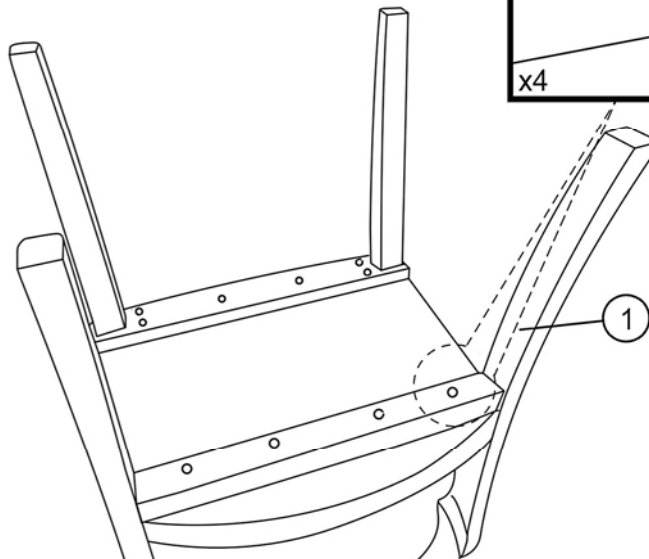
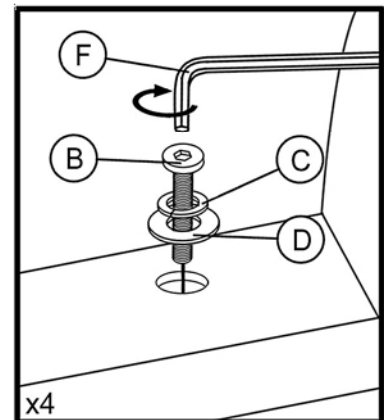

ASSEMBLY INSTRUCTIONS

3

Part ② x 1pc

Part ③ x 1pc

Hardware ④ x 6pcs

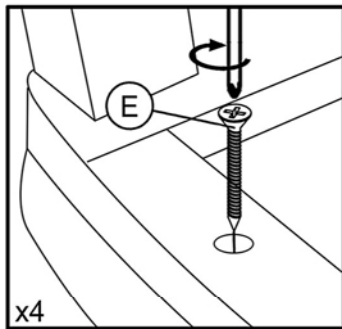

Secure the left and right side wood (#2) and (#3) onto the seat cushion (#5) by using screw (#E).

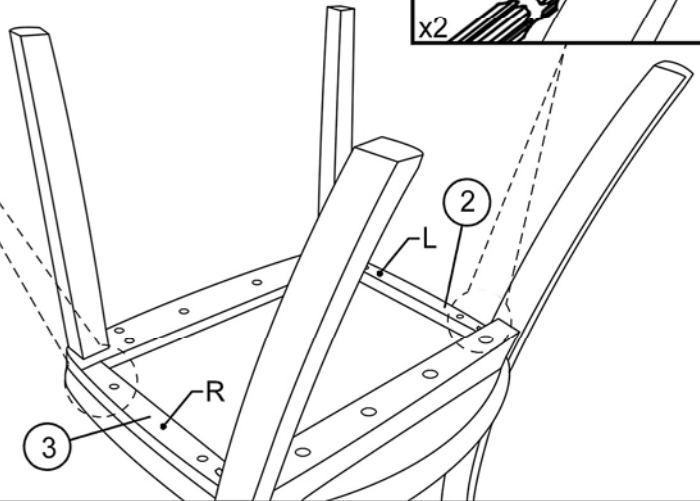
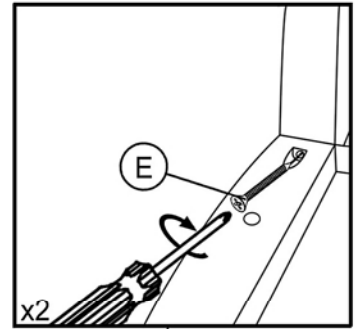

4

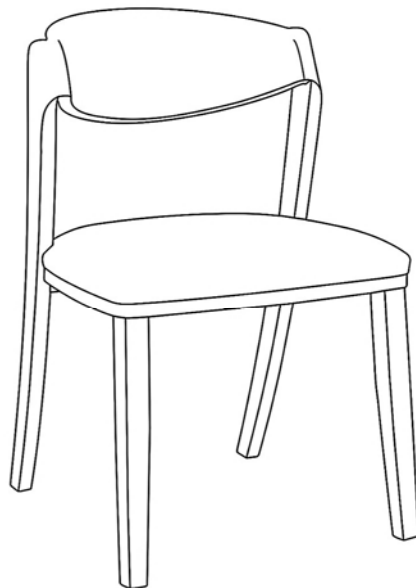

ASSEMBLY COMPLETED

Please ensure the furniture rests on an even and flat surface. If the product wobbles or feels loose, double-check all bolts and/or screws are properly tightened and secured.



Keep this handy!

Please retain this instruction manual and any order-related information for future reference.

Lift, don't drag!

To avoid damage to product please always LIFT the product when transporting or adjusting the placement.

This product is intended for RESIDENTIAL USE ONLY and not for commercial use.