

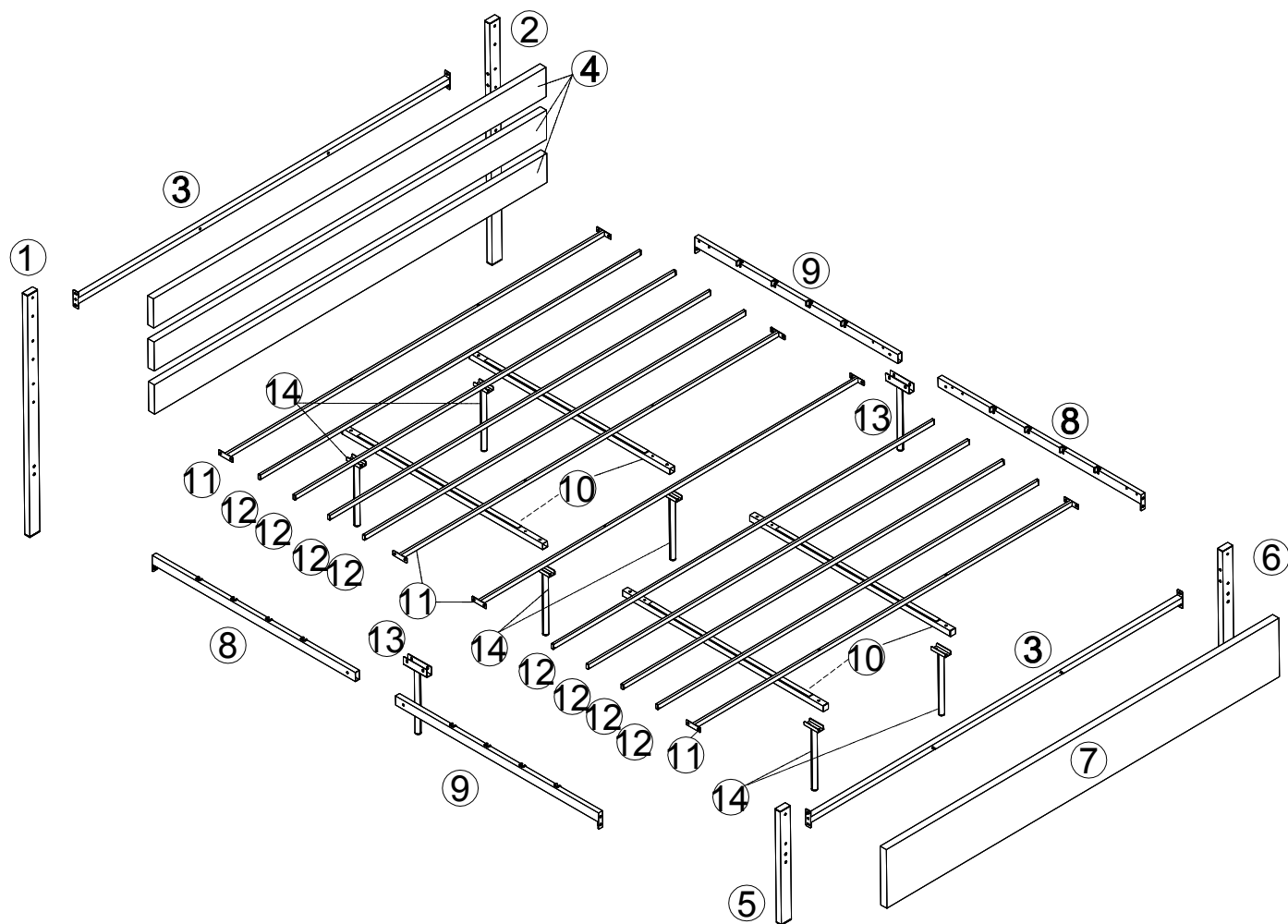

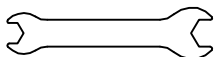





Assembly Instruction

ITEM: Bed Platform (King)

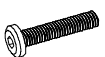
Do not tighten the screws until assembly is completed.
Align all screws with the corresponding pre-drilled holes first and then tighten them one by one



<p>A</p>  <p>1PC</p>	<p>B</p>  <p>Ø8</p> <p>8PCS</p>	<p>C M6*12</p>  <p>28PCS</p>	<p>D M6*35</p>  <p>36PCS</p>
<p>E M6*60</p>  <p>4PCS</p>	<p>F M8*40</p>  <p>8PCS</p>	<p>G</p>  <p>Ø6</p> <p>18PCS</p>	<p>H M8</p>  <p>4PCS</p>
<p>I M6</p>  <p>16PCS</p>	<p>J</p>  <p>4MM</p> <p>2PCS</p>		

Step 1:

C M6*12



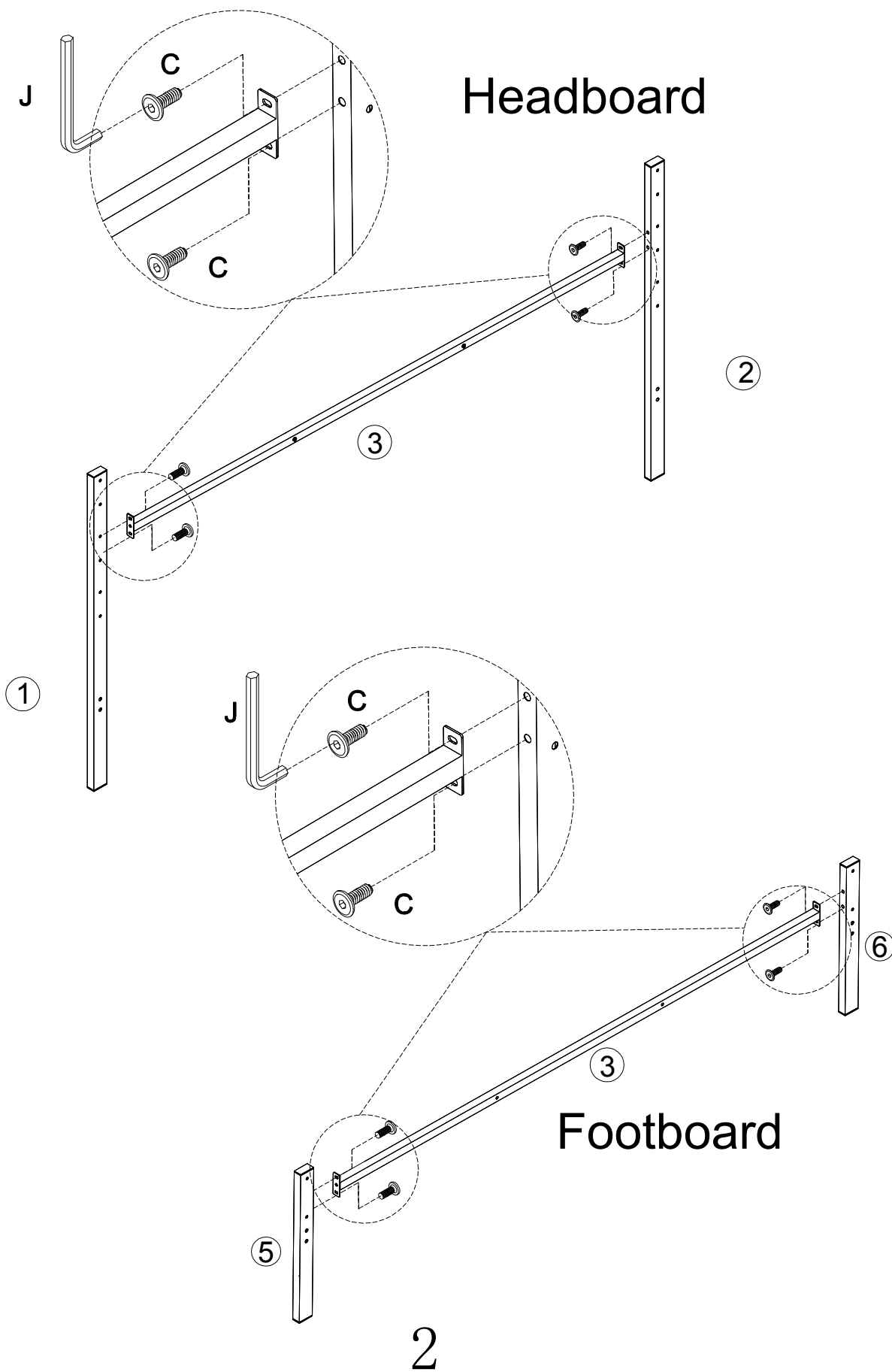

8PCS

J 4MM

1PC

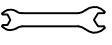
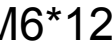
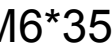

Step 2:

A 	1PC
C M6*12 	4PCS
D M6*35 	4PCS
I  M6	4PCS
G  Ø6	4PCS
J  4MM	1PC

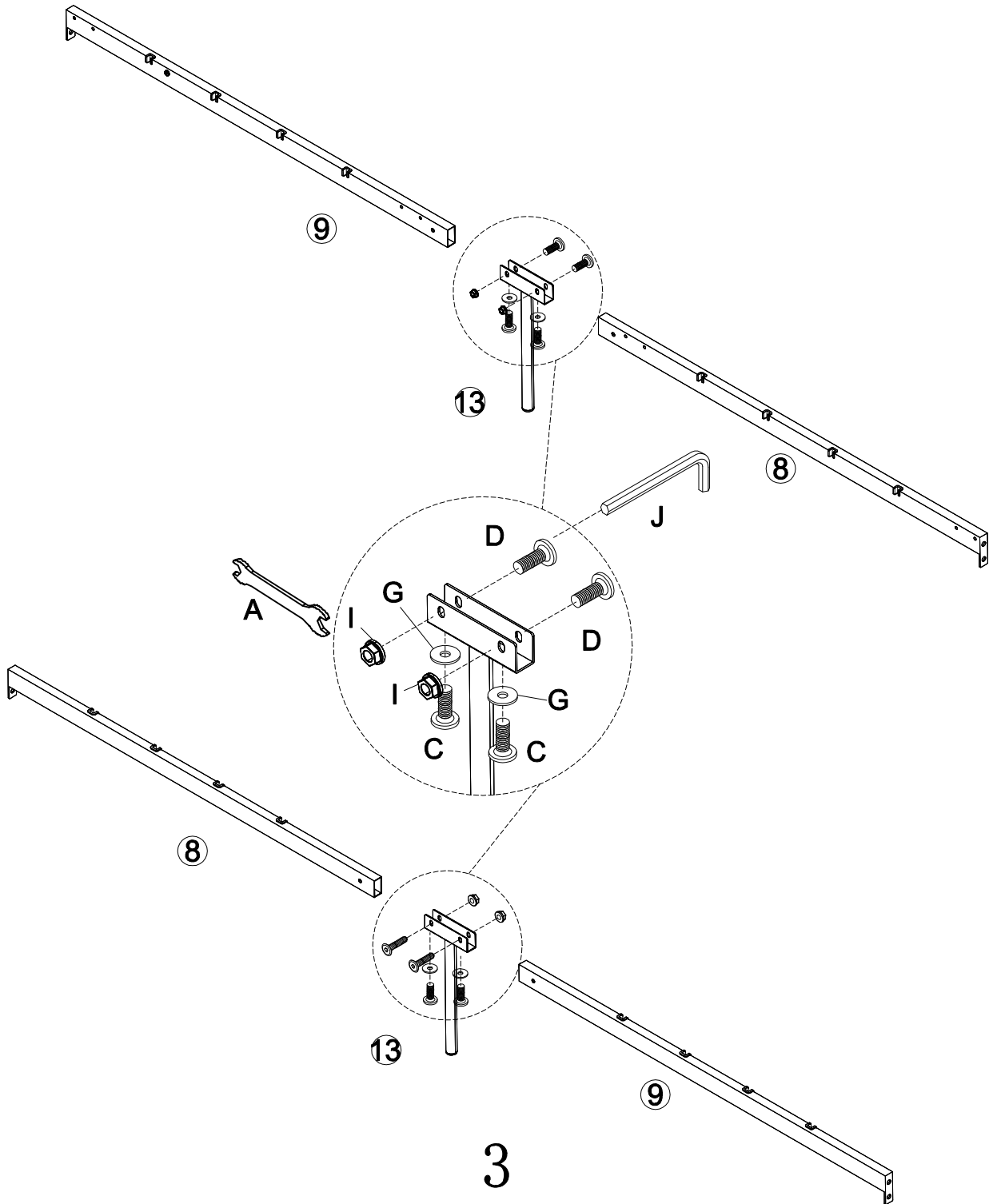

Step 3:

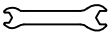
A  1PC

1PC

F M8*40 

8PCS

B  Ø8

8PCS

H  M8

4PCS

J  4MM

1PC

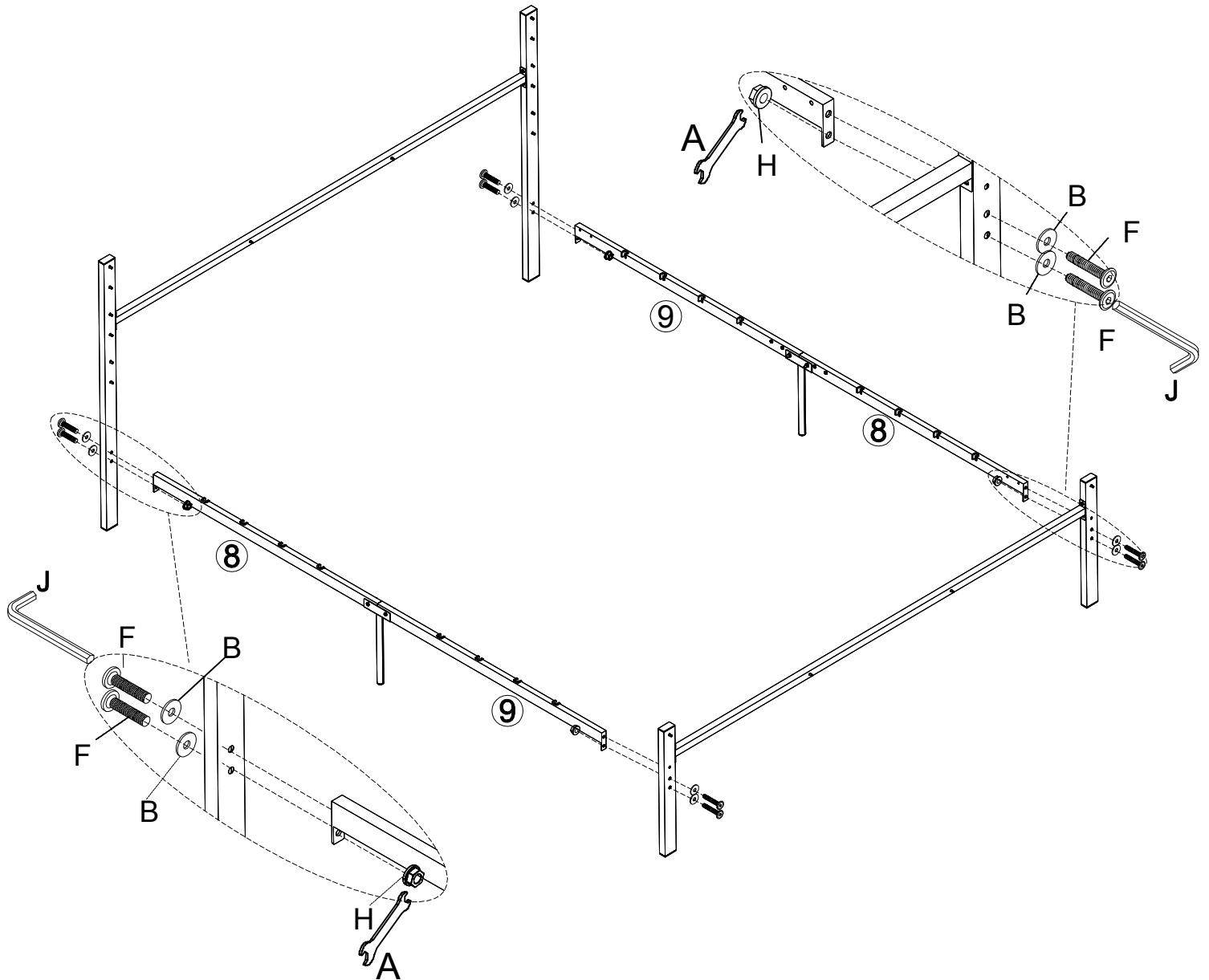

Step4:

D M6*35

14PCS

J  4MM

1PC

G  Ø6

14PCS

After all the screws are screwed into the headboard, then tighten them

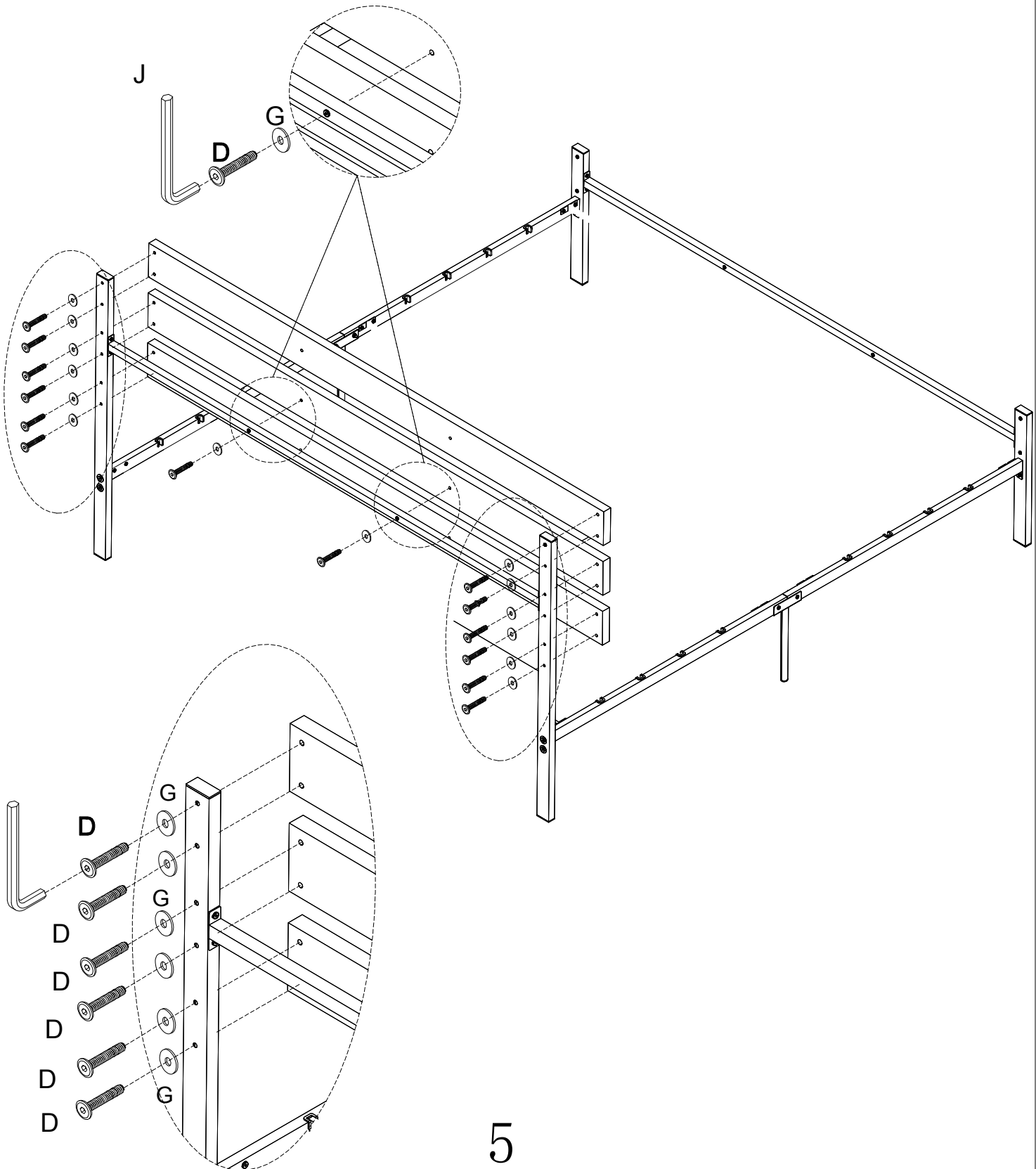

Step5 :

D M6*35

6PCS



J  4MM

1PC

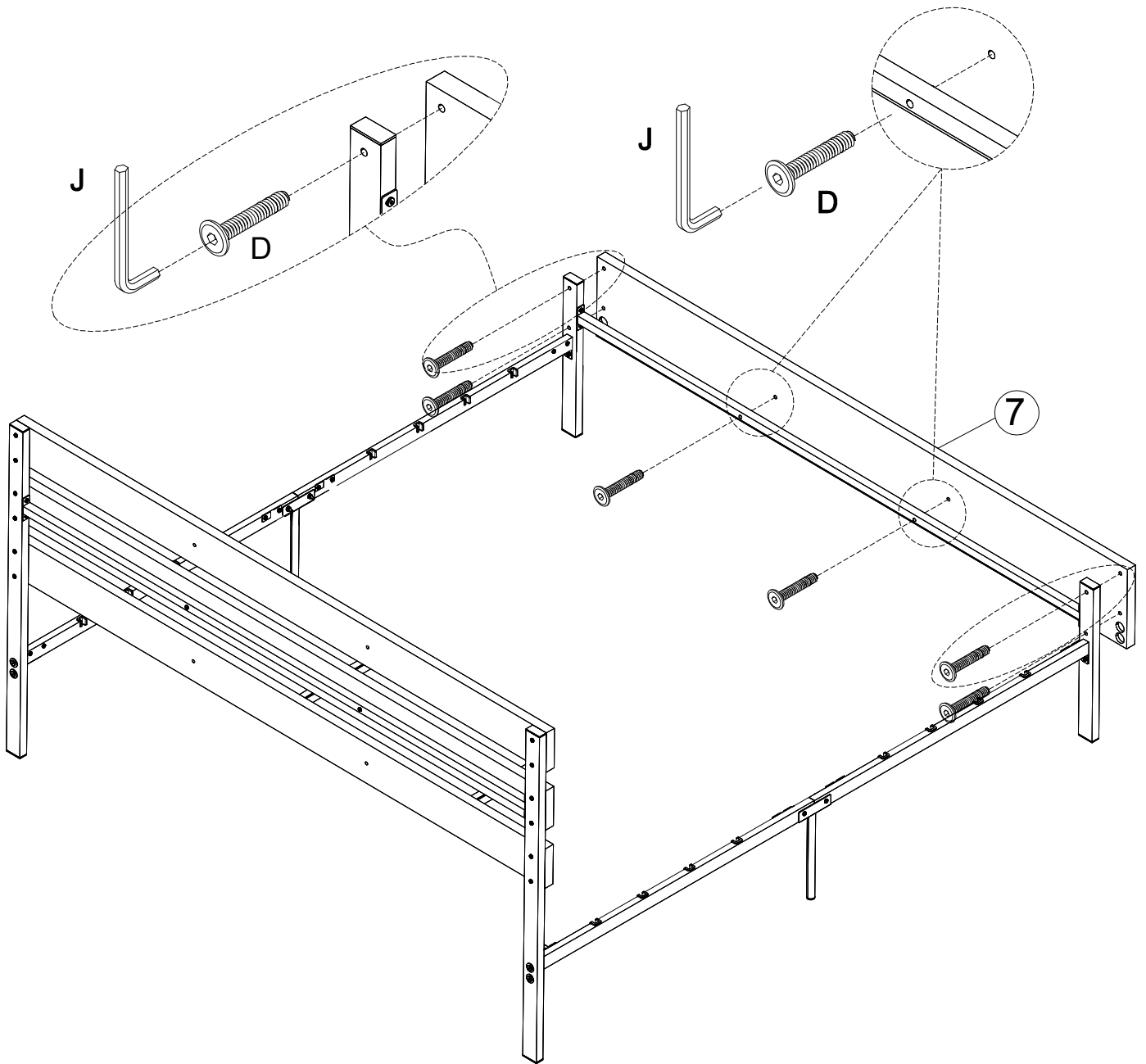
After all the screws are screwed into the footboard, then tighten them



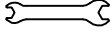

Step6:

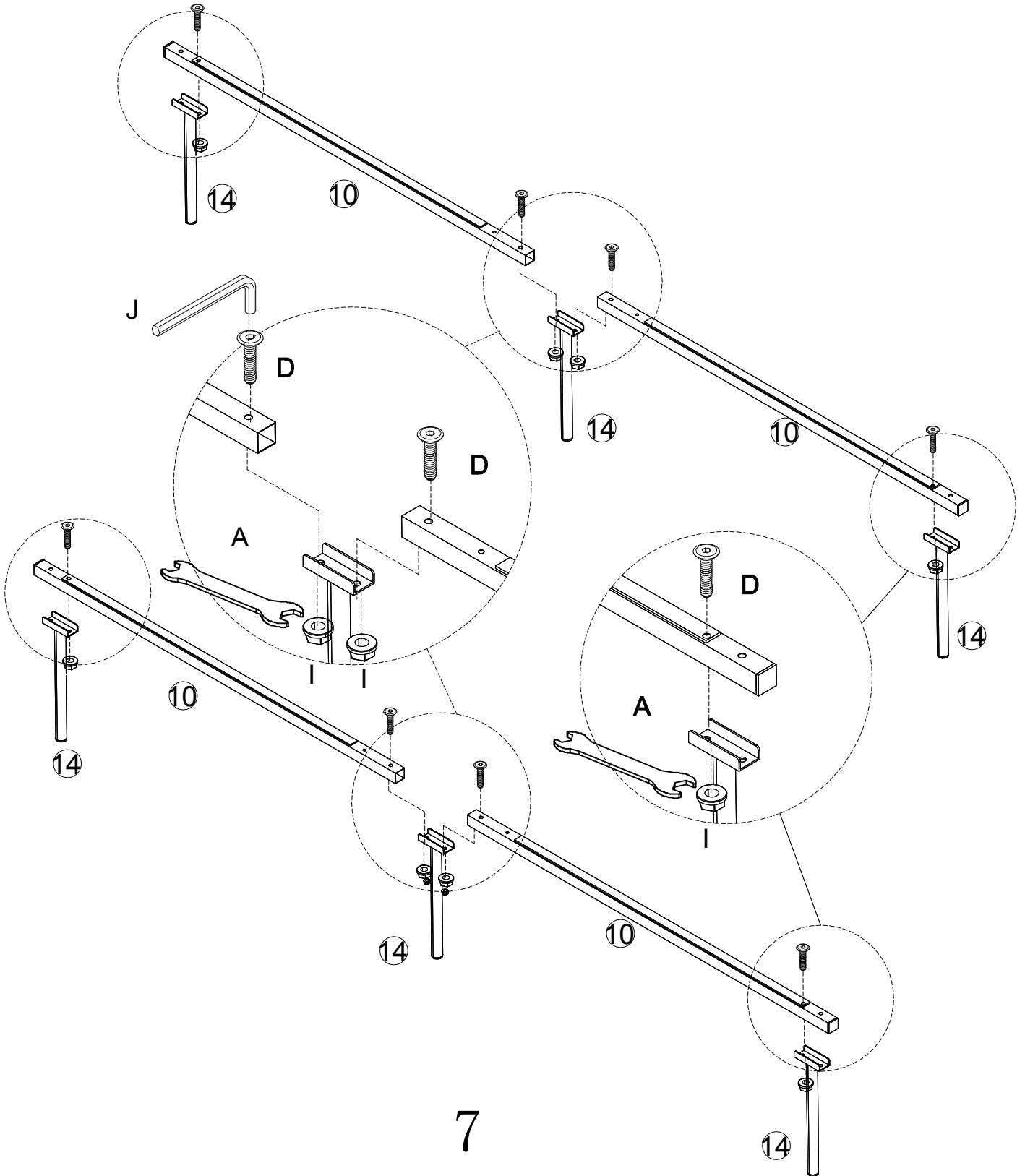
A		1PC
D	M6*35	8PCS
I	 M6	8PCS
J	 4MM	1PC

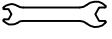

Step7:

A		1PC
E	M6*60	4PCS
D	M6*35	4PCS
I	 M6	4PCS
J	 4MM	1PC

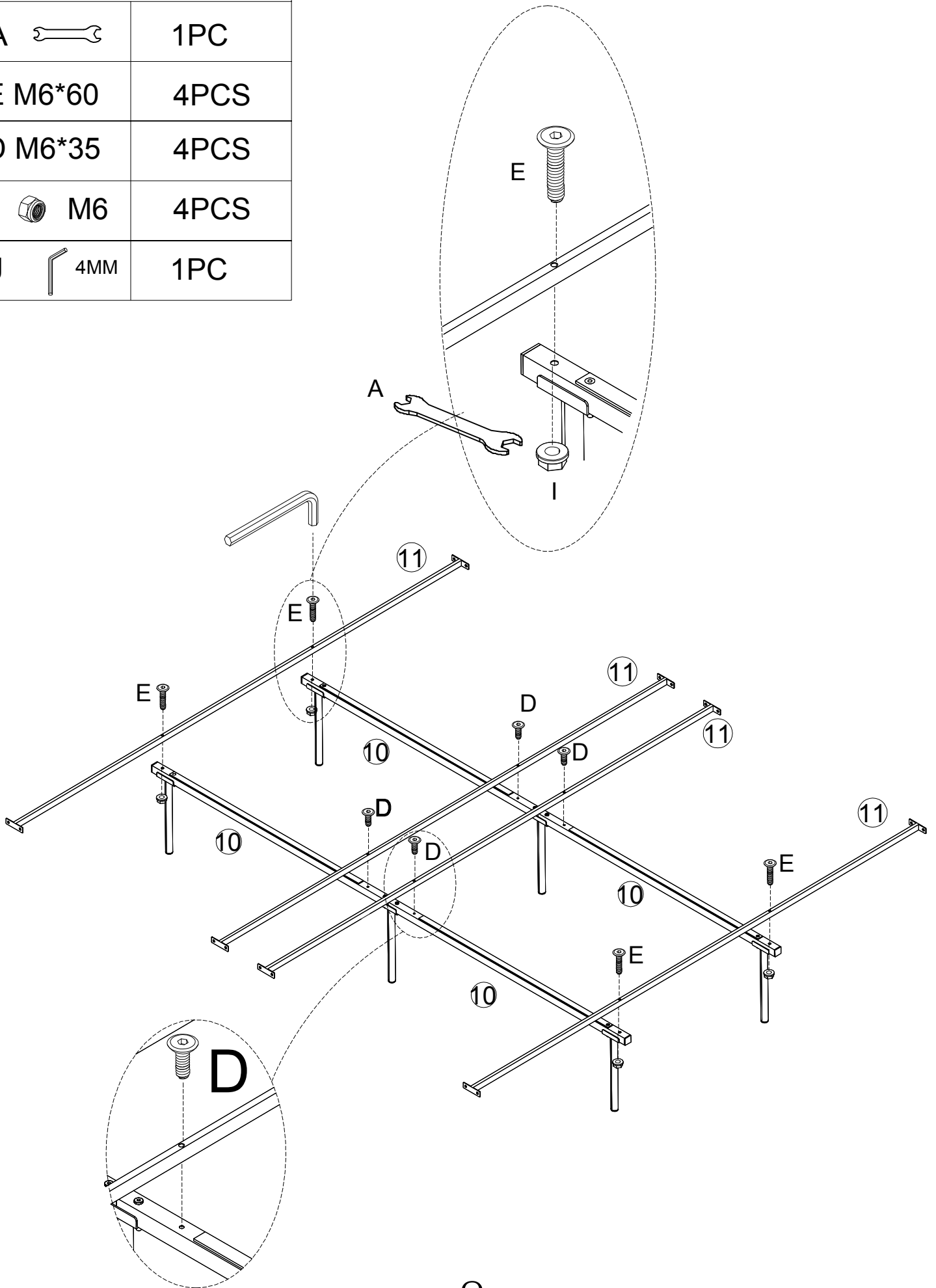

Step8:

C M6*12

16PCS

J 4MM

1PC

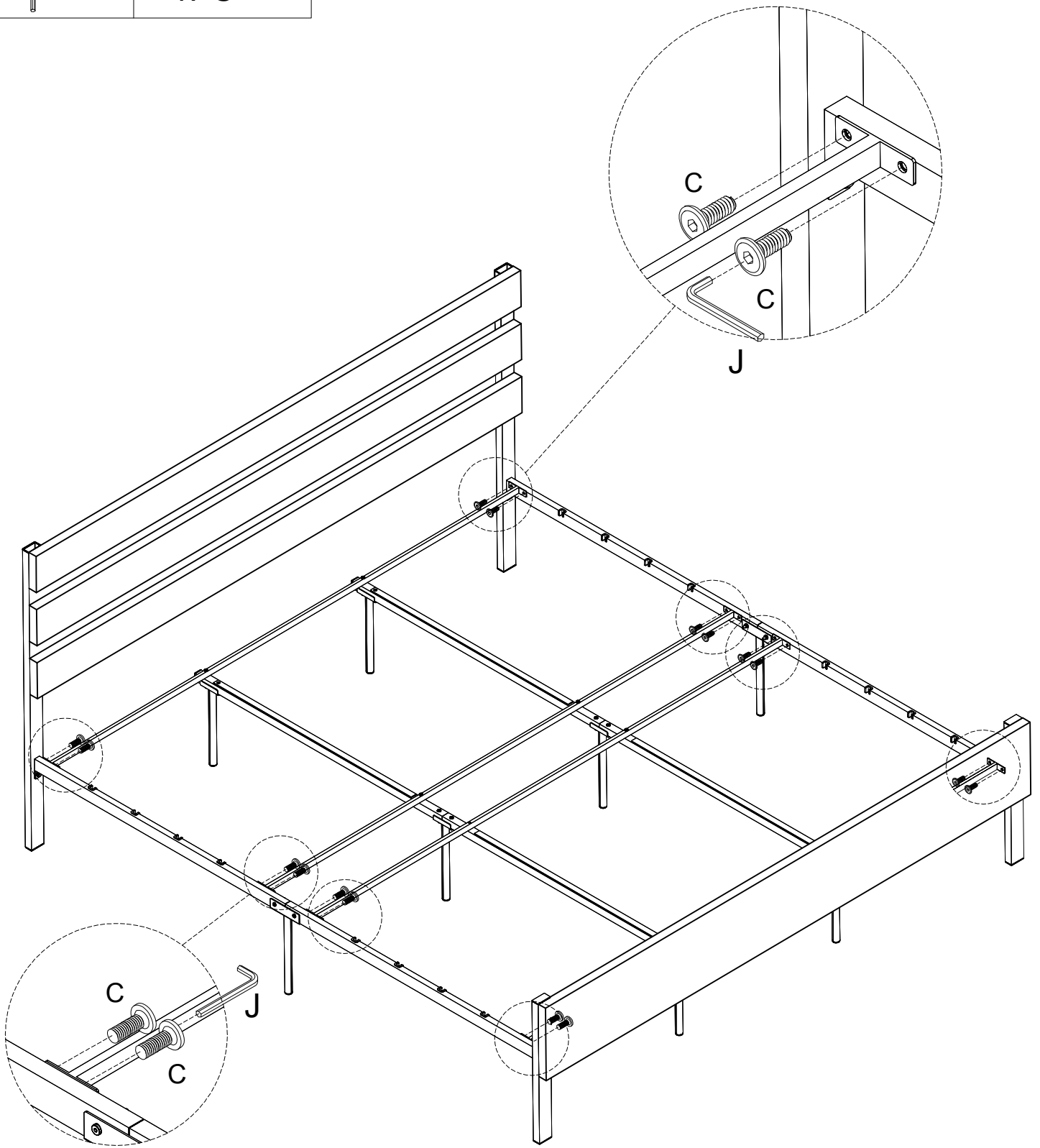

Step 9:

