

Product manual

Gebrauchsanweisung

Manuel du produit

Manual del producto

Manuale del prodotto

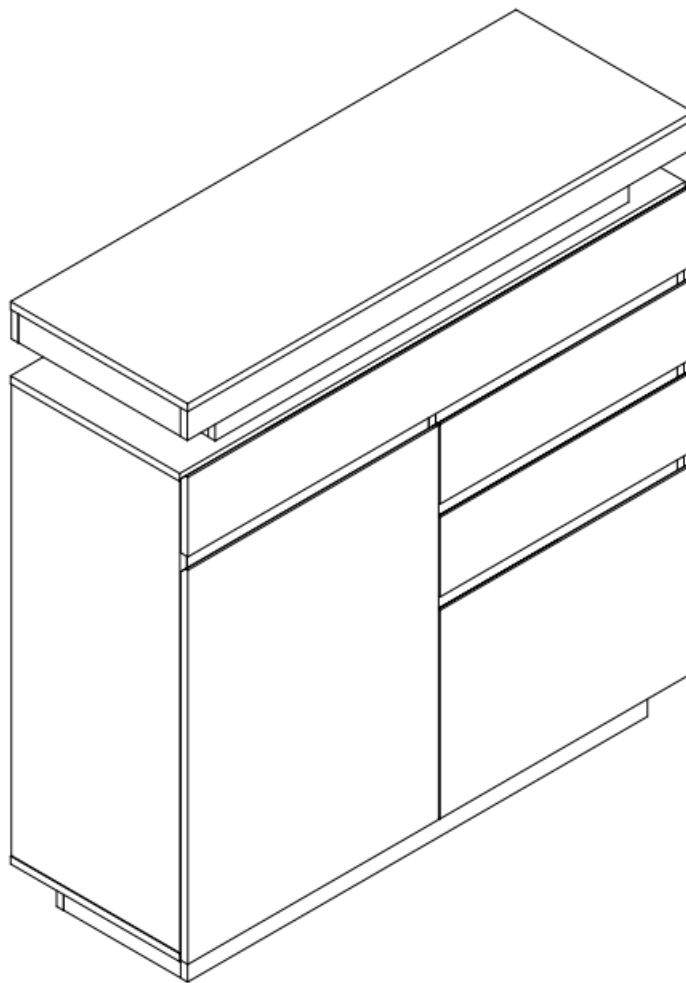

EN:Our product will be delivered to you in 2 packages.The delivery times of these 2 packages may differ,

please be patient and thank you for your understanding

FR:Notre produit vous sera livré en 2 colis.Les délais de livraison de ces 2 colis peuvent différer,soyez patient et merci de votre compréhension.

DE:Unser Produkt wird Ihnen in 2 Paketen geliefert.Die Lieferzeiten dieser 2 Paketekonnenabweichen,bitte haben Sie etwas Geduld und vielen Dank fur Ihr Verstandnis

IT:I nostri prodotti vengono trasportati in due pacchetti. I tempi di consegna dei due pacchetti sono diversi: abbiate pazienza e vi ringrazio per la vostra comprensione.

ES:Nuestro producto se entrega en dos paquetes. El tiempo de entrega de estos dos paquetes es diferente.

Por favor, sea paciente. Gracias por su comprensión.



2PERS



45 MIN

Tool Required Not Provided

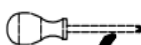
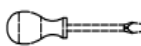

## English

### IMPORTANT ! KEEP FOR FUTURE REFERENCE : READ CAREFULLY

- To be assembled by an adult. Assembly must be checked by an adult before use.
- **WARNING !** Keep all screws, small parts and plastic bags out of the reach of children.
- Properly identify all parts before assembling.
- Anchor unit to stud or wall.
- Always use on a level, even surface.
- Avoid the risk of fire by not placing furniture near sources of ignition or hot items.
- **DO NOT** place hot or cold items directly onto the surface.
- **DO NOT** place the item next to a radiator or direct sunlight.
- **DO NOT** allow children to climb on unit.
- **DO NOT** put the product in a humid environment.

## Deutsch

### WICHTIG ! ZUM SPÄTEREN NACHSCHLAGEN AUFBEWAHREN: SORGFÄLTIG LESEN

- Muss von einem Erwachsenen zusammengebaut werden. Der Zusammenbau muss vor der Benutzung von einem Erwachsenen überprüft werden.
- **WARNUNG!** Bewahren Sie alle Schrauben, Kleinteile und Plastikbeutel außerhalb der Reichweite von Kindern auf.
- Kennzeichnen Sie vor dem Zusammenbau alle Teile ordnungsgemäß.
- Verankern Sie das Gerät an einem Ständer oder einer Wand.
- Benutzen Sie das Gerät immer auf einer ebenen, geraden Fläche.
- Vermeiden Sie das Risiko eines Brandes, indem Sie die Möbel nicht in der Nähe von Zündquellen oder heißen Gegenständen aufstellen.
- Stellen Sie **KEINE** heißen oder kalten Gegenstände direkt auf die Oberfläche.
- Stellen Sie das Gerät **NICHT** in der Nähe eines Heizkörpers oder direkter Sonneneinstrahlung auf.
- Erlauben Sie Kindern **NICHT**, auf das Gerät zu klettern.
- Stellen Sie das Gerät **NICHT** in einer feuchten Umgebung auf.

## Français

### IMPORTANT ! CONSERVER POUR RÉFÉRENCE ULTÉRIEURE : LIRE ATTENTIVEMENT

- A assembler par un adulte. Le montage doit être vérifié par un adulte avant utilisation.
- **ATTENTION !** Conservez toutes les vis, les petites pièces et les sacs en plastique hors de portée des enfants.
- Identifiez correctement toutes les pièces avant de les assembler.
- Fixer l'appareil à un montant ou à un mur.
- Utilisez toujours l'appareil sur une surface plane et uniforme.
- Évitez les risques d'incendie en ne plaçant pas les meubles à proximité de sources d'inflammation ou d'objets chauds.
- **NE PAS** placer d'objets chauds ou froids directement sur la surface.
- **NE PAS** placer l'appareil à côté d'un radiateur ou de la lumière directe du soleil.
- **NE PAS** laisser les enfants grimper sur l'appareil.
- **NE PAS** placer le produit dans un environnement humide.

**Italiano**

**IMPORTANTE! CONSERVARE PER RIFERIMENTO FUTURO: LEGGERE ATTENTAMENTE**

- Deve essere assemblato da un adulto. L'assemblaggio deve essere controllato da un adulto prima dell'uso.
- **AVVERTENZA !** Tenere tutte le viti, le piccole parti e i sacchetti di plastica fuori dalla portata dei bambini.
- Identificare correttamente tutte le parti prima dell'assemblaggio.
- Ancorare l'unità a un pilastro o a una parete.
- Utilizzare sempre su una superficie piana e uniforme.
- Evitare il rischio di incendio non collocando i mobili vicino a fonti di accensione o ad oggetti caldi.
- **NON** collocare oggetti caldi o freddi direttamente sulla superficie.
- **NON** collocare l'apparecchio vicino a un termosifone o alla luce diretta del sole.
- **NON** permettere ai bambini di arrampicarsi sull'unità.
- **NON** collocare il prodotto in un ambiente umido.

**Español**

**¡ IMPORTANTE ! CONSERVELO PARA FUTURAS CONSULTAS: LEA ATENTAMENTE**

- Debe montarlo un adulto. El montaje debe ser comprobado por un adulto antes del uso.
- **ADVERTENCIA** Mantenga todos los tornillos, piezas pequeñas y bolsas de plástico fuera del alcance de los niños.
- Identifique correctamente todas las piezas antes del montaje.
- Ancle la unidad a un montante o pared.
- Utilí celo siempre sobre una superficie plana y nivelada.
- Evite el riesgo de incendio no colocando los muebles cerca de fuentes de ignición o artículos calientes.
- **NO** coloque objetos calientes o fríos directamente sobre la superficie.
- **NO** coloque el mueble cerca de un radiador o de la luz solar directa.
- **NO** permita que los niños se suban a la unidad.
- **NO** coloque el producto en un ambiente húmedo.

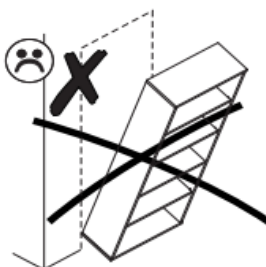
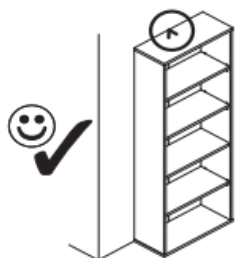

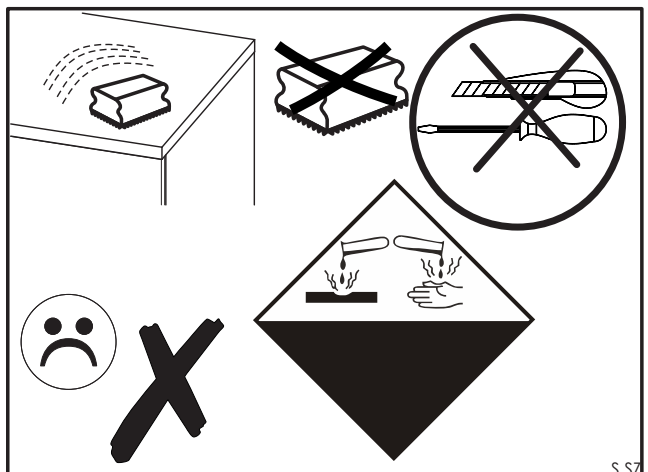
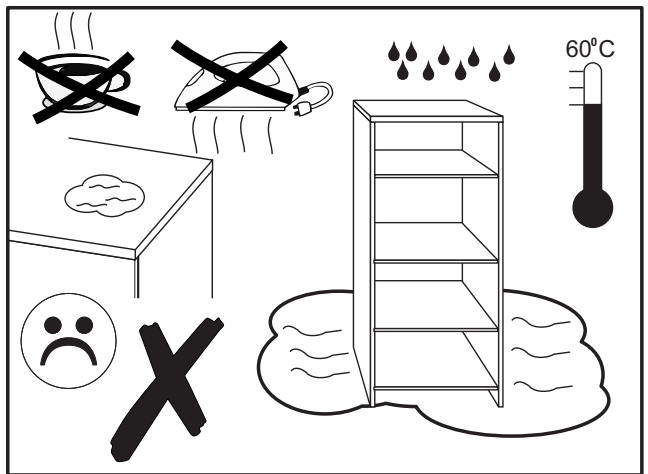
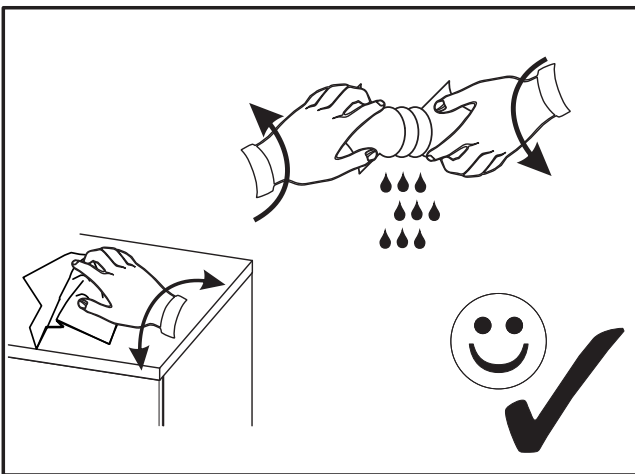
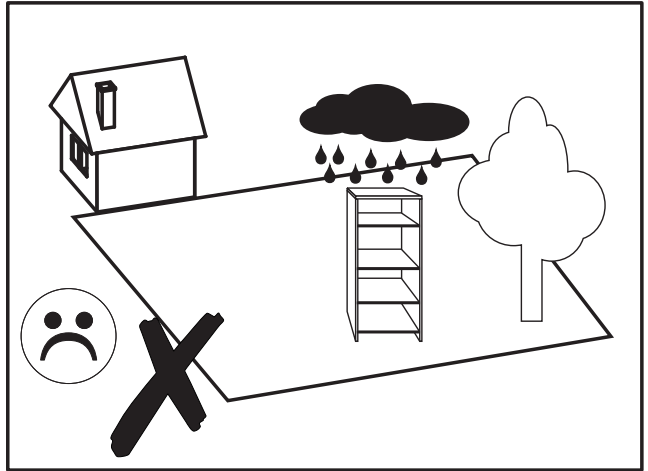
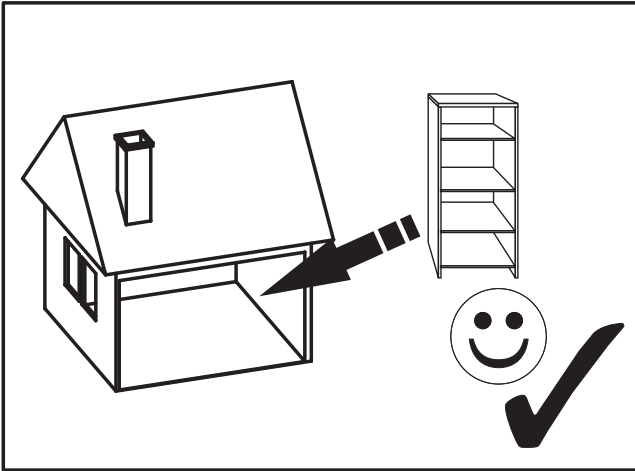

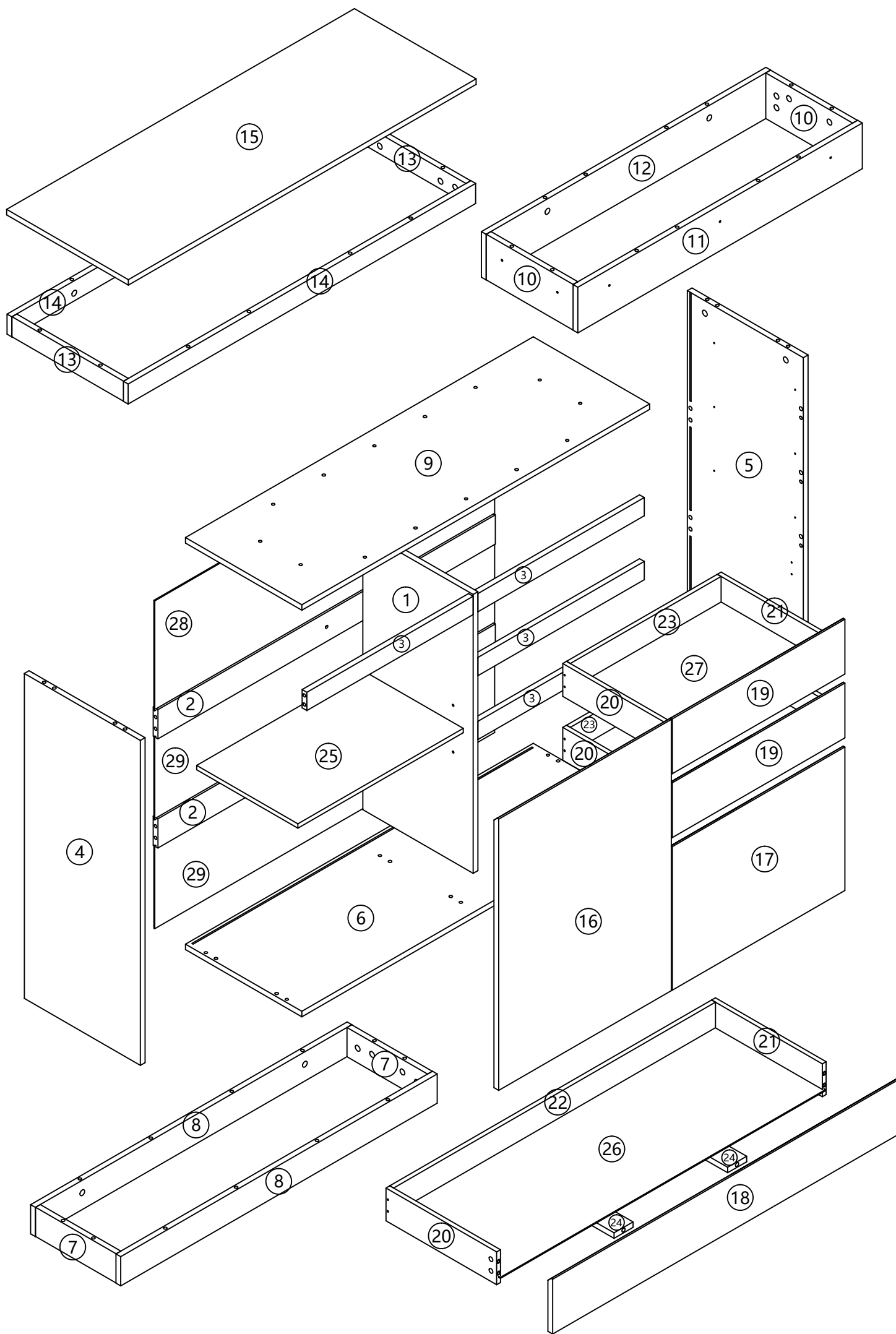

# N601P220641W

2

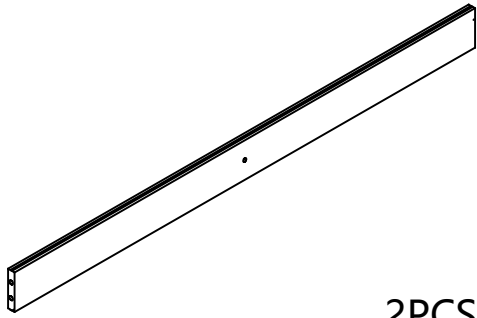

2PCS

6

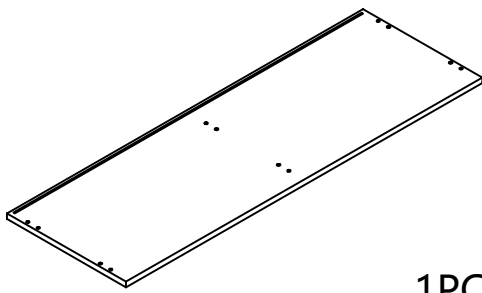

1PC

7

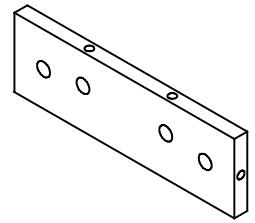

2PCS

8

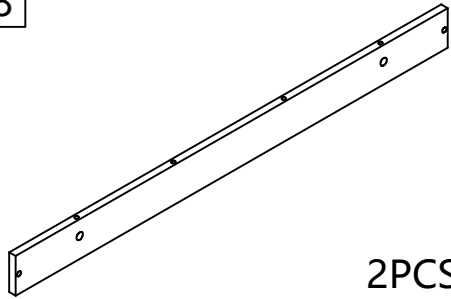

2PCS

9

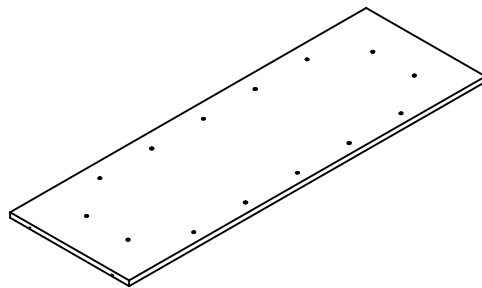

1PC

10

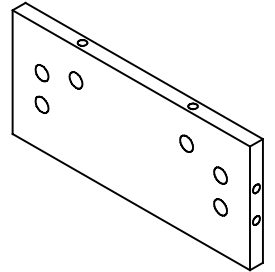

2PCS

11

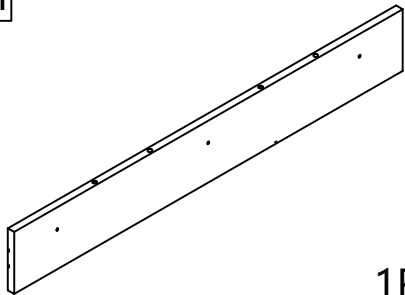

1PC

14

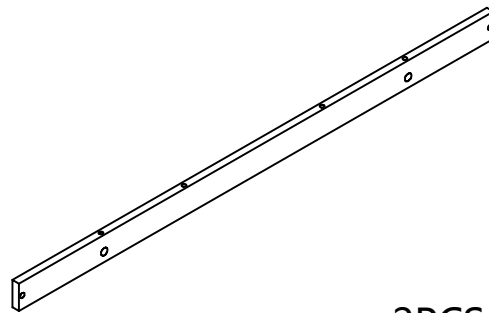

2PCS

15

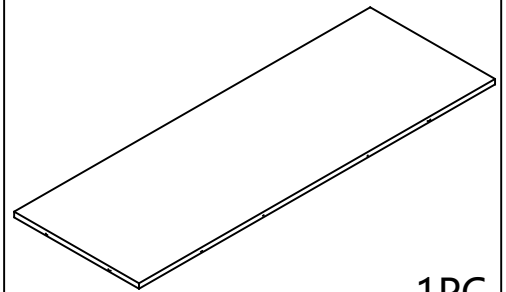

1PC

12

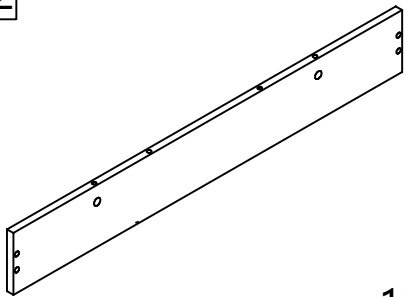

1PC

22

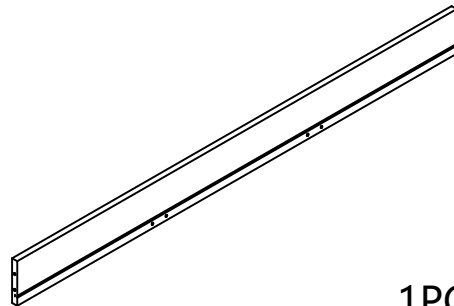

1PC

26

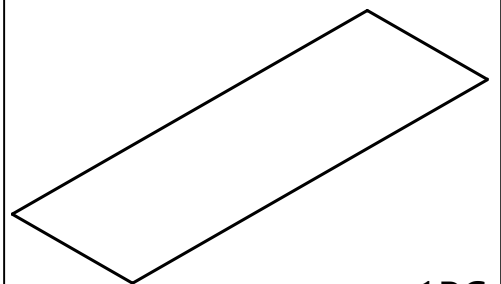

1PC

18

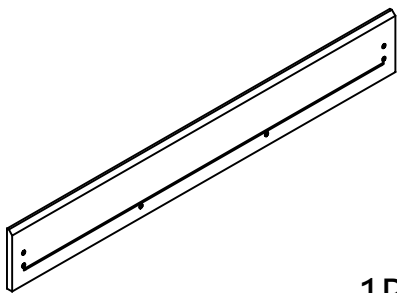

1PC

28

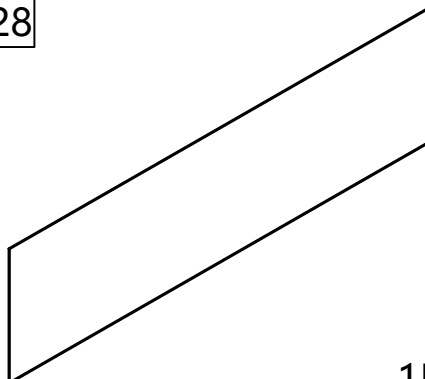

1PC

29

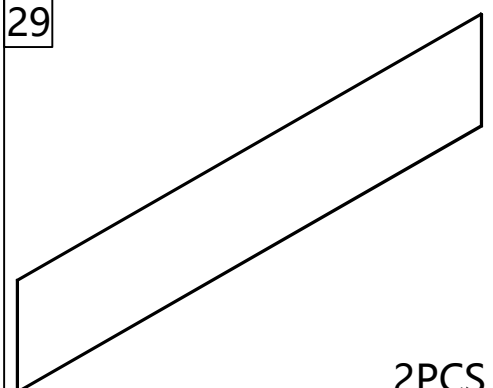

2PCS

27

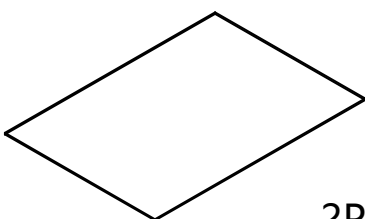

2PCS

# N601P220642W

1

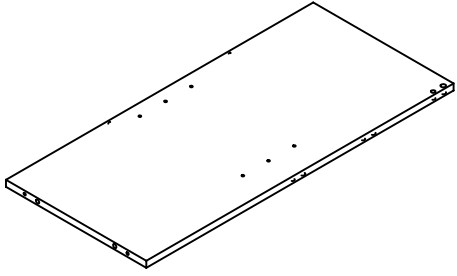

1PC

3

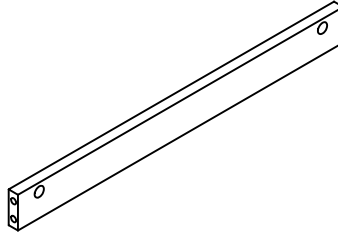

4PCS

4

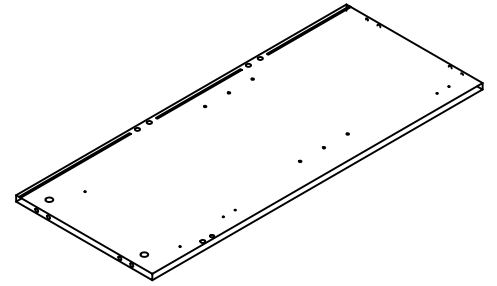

1PC

5

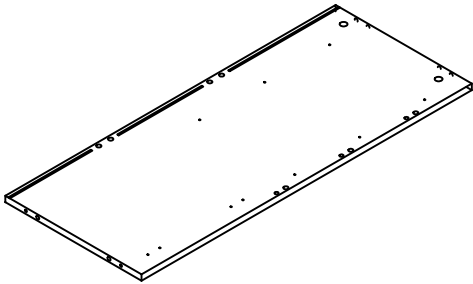

1PC

13

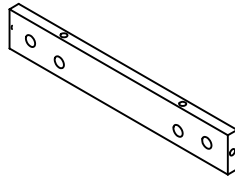

2PC

16

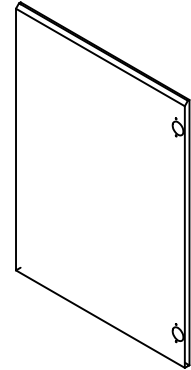

1PC

17

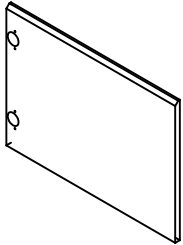

1PC

19

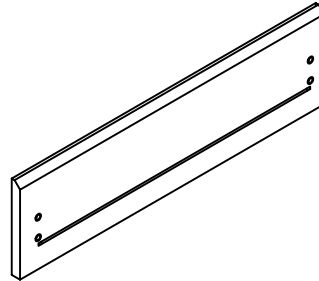

2PCS

20

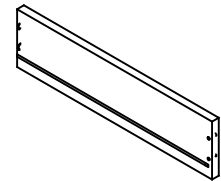

3PCS

21

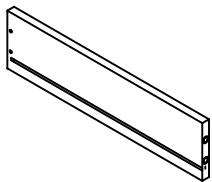

3PCS

23

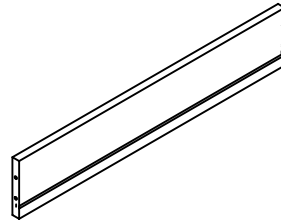

2PCS

24

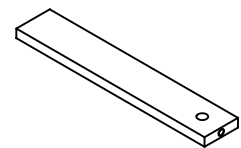





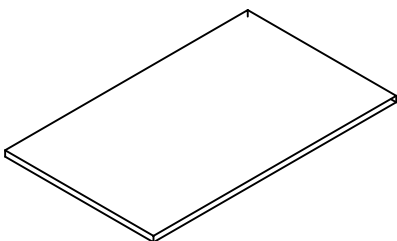

2PCS

25

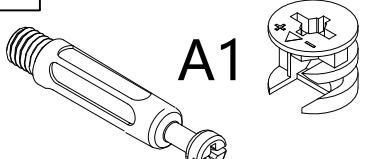
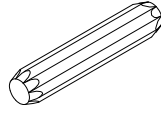

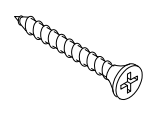
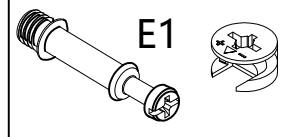
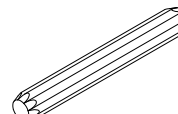
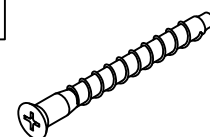
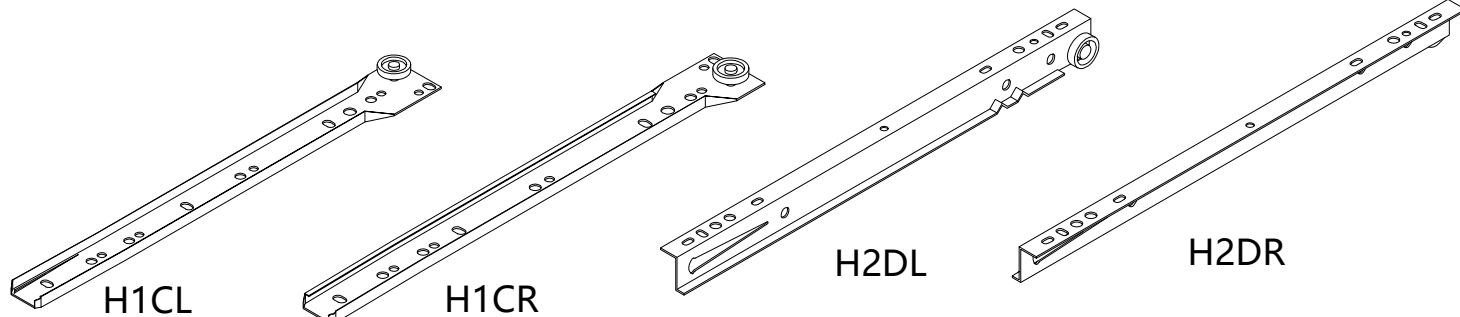
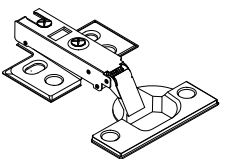
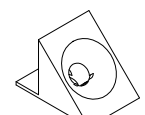
1PC

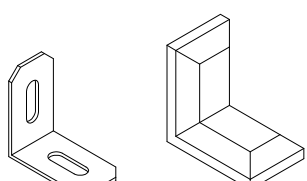
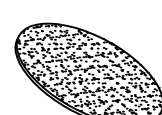
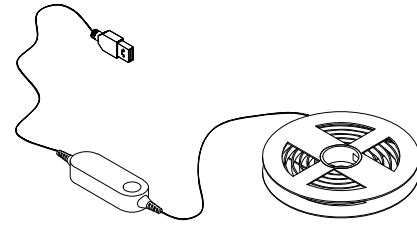
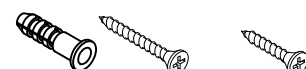
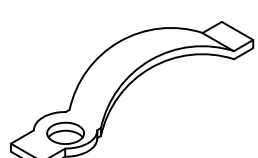
# N601P220642W

<p><b>A</b></p>  <p>A1 A2</p> <p>62STES</p>	<p><b>B</b></p>  <p>8×40mm</p> <p>32PCS</p>	<p><b>C</b></p>  <p>3.5×14mm</p> <p>66PCS</p>	
<p><b>D</b></p>  <p>3.5×35mm</p> <p>16PCS</p>	<p><b>E</b></p>  <p>E1 E2</p> <p>12STES</p>	<p><b>F</b></p>  <p>8×70mm</p> <p>1PC</p>	<p><b>G</b></p>  <p>7x50mm</p> <p>18PCS</p>
<p><b>H</b></p>  <p>H1CL H1CR H2DL H2DR</p> <p>350mm 2STES</p>			
<p><b>J</b></p>  <p>4PCS</p>	<p><b>K</b></p>  <p>18PCS</p>	<p><b>L</b></p>  <p>4PCS</p>	<p><b>M</b></p> 
<p><b>N</b></p>  <p>8PCS</p>	<p><b>P</b></p>  <p>1STE</p>		<p><b>M</b></p>  <p>2STES</p>
<p><b>Q</b></p>  <p>7PCS</p>	<p><b>R</b></p>  <p>3×12mm</p> <p>7PCS</p>		

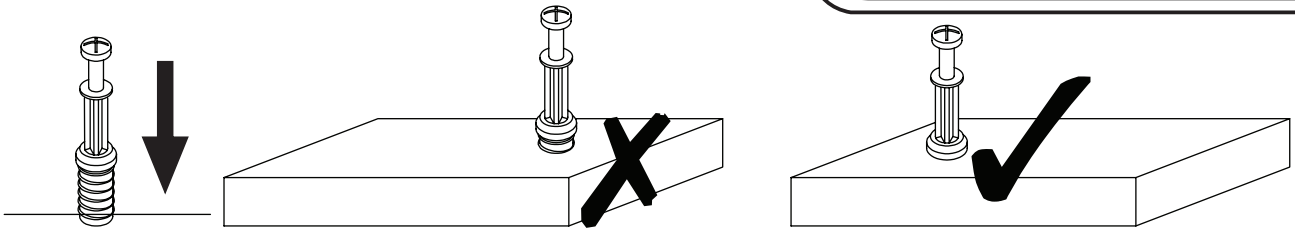

**EN\_QUICKFIT:** Tighten quickfit until shoulder is flush with panel. Do not overtighten or undertighten.

**FR\_RACCORD RAPIDE:** Faites serrer le raccord rapide jusqu'à ce que l'épaulement soit parfaitement encastré dans le panneau. Il ne faut ni trop serrer ni insuffisamment serrer.

**ES\_QUICKFIT:** Apriete quickfit hasta que el hombro se descargue con el panel. NO lo sobreapriete ni lo apriete poco.

**DE\_QUICKFIT:** Ziehen Sie den Quickfit fest, bis die Schulter mit der Platte bündig ist. Bitte nicht zu fest oder zu schwach anziehen.

**IT\_MONTAGGIO RAPIDO:** Stringere il montaggio rapido fino a quando la spalla è a filo con il pannello, non stringere troppo o troppo poco.

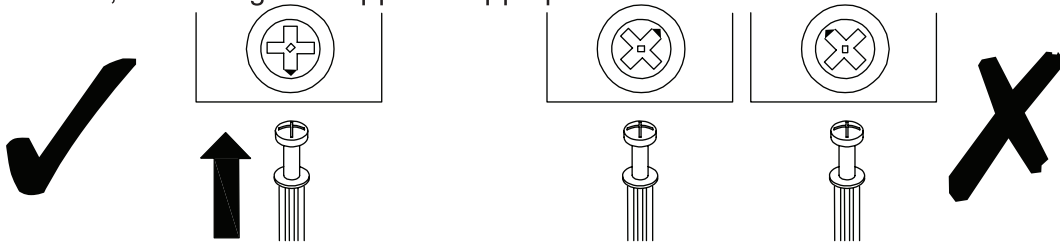

**EN\_CAM LOCK:** When fitting cam lock, ensure starting position is correct before you insert connecting quickfit.

**FR\_SERRURE BATTEUSE:** Avant d'insérer la serrure batteuse, veillez à la bonne orientation avant d'insérer le raccord rapide.

**ES\_CIERRE DE LA CÁMARA:** Cuando instale el cierre de la cámara, asegúrese de que la posición de inicio es correcta antes de que inserte el quickfit conector.

**DE\_CAM-LOCK:** Achten Sie bei der Montage des Cam-Locks auf die richtige Ausgangsposition, bevor Sie den Quickfit einsetzen.

**IT\_BLOCCAGGIO A CAMMA:** Quando si monta il bloccaggio a camma, assicurarsi che la posizione iniziale sia corretta prima di inserire il montaggio rapido di collegamento.

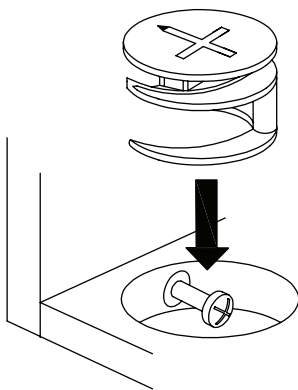

**EN\_Quickfit head** should be in the centre of the cam lock when the two panels are joined.

Cam lock should be inserted before quickfit.

**FR\_Lorsque** les deux panneaux sont assemblés, la tête du raccord rapide doit reposer au centre de la serrure batteuse. Il faut insérer la serrure batteuse avant le raccord rapide.

**ES\_El** cabezal del quickfit debe estar en el centro del cierre de la cámara cuando se unan los dos paneles.

Se debe insertar el cierre de la cámara antes que el quickfit.

**DE\_Der** Quickfit-Kopf sollte sich in der Mitte des Cam-Locks befinden, wenn die beiden Platten zusammengefügt sind. Der Cam-Lock sollte vor dem Quickfit eingesetzt werden.

**IT\_La** testa del montaggio rapido deve trovarsi al centro del bloccaggio a camma quando i due pannelli sono uniti.

Il Bloccaggio a Camma deve essere inserito prima del montaggio rapido.

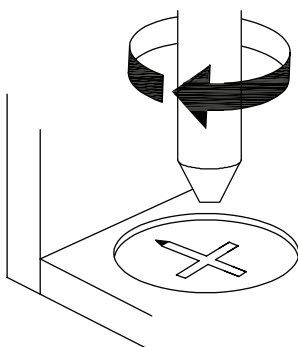

**EN\_Turn** cam lock clockwise to tighten.

**FR\_Faites** tourner la serrure batteuse dans le sens des aiguilles d'une montre pour la resserrer.

**ES\_Gire** el cierre de la cámara en sentido horario para apretarlo.

**DE\_Drehen** Sie den Cam-Lock im Uhrzeigersinn, um ihn festzuziehen.

**IT\_Ruotare** il bloccaggio a camma in senso orario per stringere.

**EN\_** It may be necessary to adjust the hinges so that the doors align. Use the instructions below as a guide.

**FR\_** Il est parfois nécessaire d'ajuster les charnières pour un meilleur alignement des portes. Servez-vous des instructions ci-dessous comme guide.

**ES\_** Puede que sea necesario ajustar los quicios de forma que se alineen las puertas. Use las instrucciones que aparecen debajo como guía.

**DE\_** Möglicherweise müssen Sie die Scharniere so einstellen, dass die Türen ausgerichtet sind. Verwenden Sie die nachstehenden Anweisungen als Leitfaden.

**IT\_** Potrebbe essere necessario regolare le cerniere in modo che le porte siano allineate. Per fare ciò attenersi alle istruzioni sottostanti.

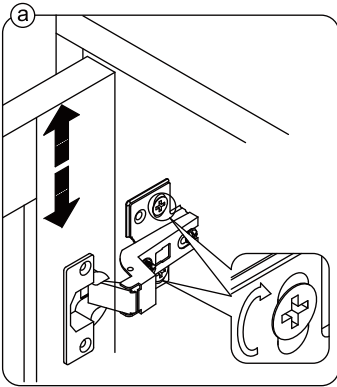

**EN\_** To adjust the door vertically loosen the screw as shown and move up and down as needed.

**FR\_** Si vous souhaitez régler la porte **verticalement**, desserrez la vis comme indiqué et déplacez la porte de haut en bas selon les besoins.

**ES\_** Para ajustar la puerta **verticalmente** afloje el tornillo tal y como se muestra y muévelo hacia arriba o hacia abajo según sea necesario.

**DE\_** Um die Tür **vertikal** auszurichten, lösen Sie die Schraube wie abgebildet und bewegen Sie sie nach Bedarf nach oben oder nach unten.

**IT\_** Per allineare la porta **verticalmente** allentare la vite come mostrato e spostarla in alto o in basso secondo necessità.

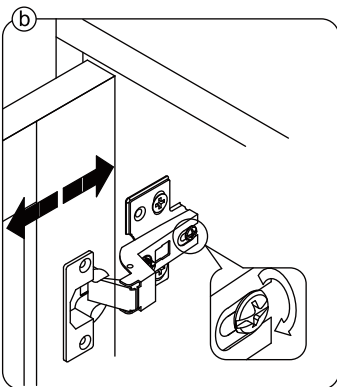

**EN\_** To adjust the gap from the door to the main frame turn the screw clockwise or anti-clockwise as needed.

**FR\_** Si vous souhaitez ajuster l'**écart** entre la porte et le cadre principal, tournez la vis dans le sens des aiguilles d'une montre ou dans le sens inverse, si nécessaire.

**ES\_** Para ajustar el **espacio** desde la puerta al marco principal, gire el tornillo en sentido horario o antihorario, según se necesite.

**DE\_** Um den **Abstand** von der Tür zum Hauptrahmen auszurichten, drehen Sie die Schraube je nach Bedarf im oder gegen den Uhrzeigersinn.

**IT\_** Per regolare lo **spazio** tra la porta e il telaio principale, avvitare o svitare la vite secondo necessità.

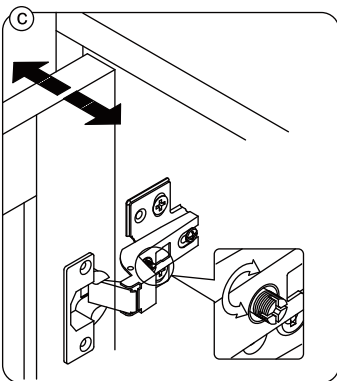

**EN\_** To adjust the door laterally adjust the screw as shown by turning clockwise or anti-clockwise.

**FR\_** Si vous souhaitez ajuster la porte **latéralement**, ajustez la vis comme indiqué en tournant dans le sens des aiguilles d'une montre ou dans le sens inverse des aiguilles d'une montre.

**ES\_** Para ajustar la puerta **lateralmente** ajuste el tornillo tal y como se muestra girándolo en sentido horario y antihorario.

**DE\_** Um die Tür **seitlich** auszurichten, stellen Sie bitte die Schraube wie abgebildet durch Drehen im oder gegen den Uhrzeigersinn ein.

**IT\_** Per allineare la porta **lateralmente** regolare la vite come mostrato, avvitarandola o svitarandola.

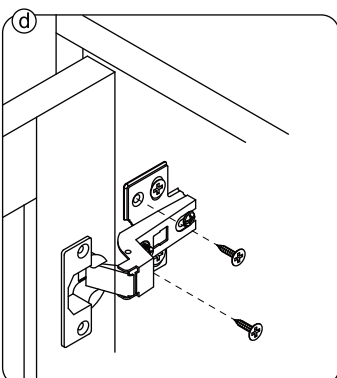

**EN\_** Please fix other screws

**FR\_** Merci de serrer les autres vis.

**ES\_** Fije los demás tornillos

**DE\_** Befestigen Sie bitte die anderen Schrauben

**IT\_** Fissare le altre viti

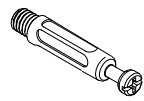
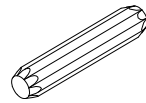
**1****A1×4****B×2****C×4**

3.5×14mm

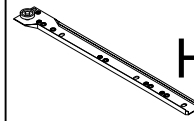
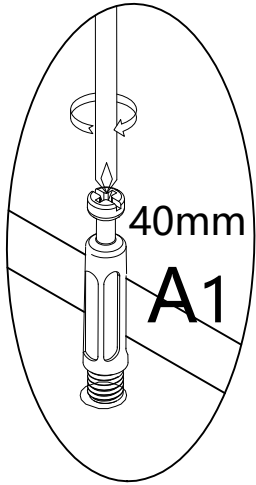
**H1CL×2**

40mm

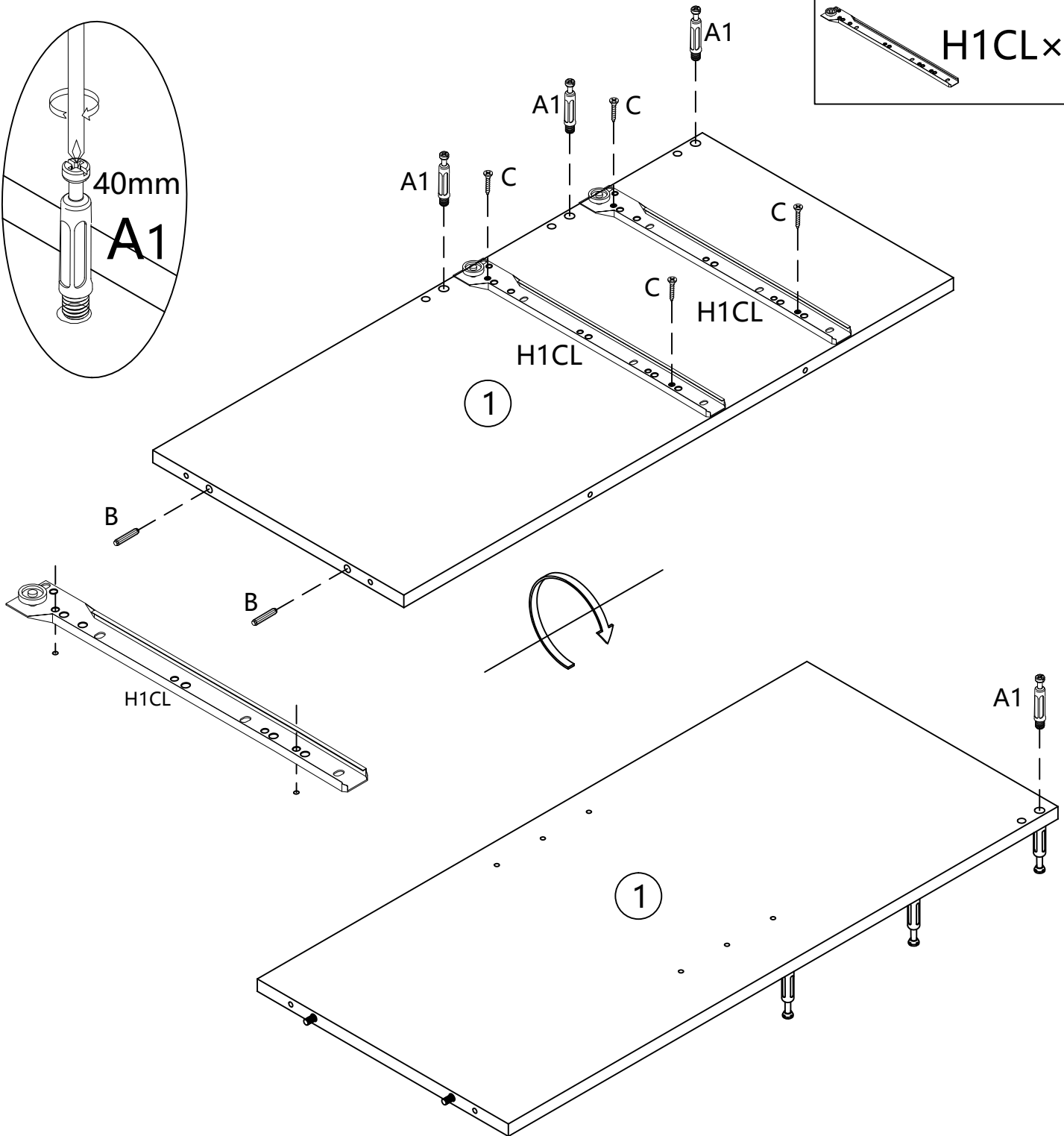
**A1**

EN:When installing, please make sure the screws are flattened,Not crooked;  
Otherwise the drawers will not be installed perfectly.

DE:Bei der Installation stellen Sie bitte sicher,  
dass die Schrauben abgeflacht sind,nicht schief; Andernfalls werden  
dieSchubladen nicht perfekt inst alliert.

FR:Lors de l'installation, assurez - vous que les vis sont plates et non pliées;  
Sinon, le tiroir ne s'installe ra pas parfaitement.

IT:Durante l'installazione, assicurarsi che le viti siano piatte e non piegate,  
altrimenti il cassetto non si  
installerà perfettamente.

ES:Al instalar, asegúrese de que los tornillos estén planos y no doblados, de lo  
contrario, el cajón no  
se instalará perfectamente;

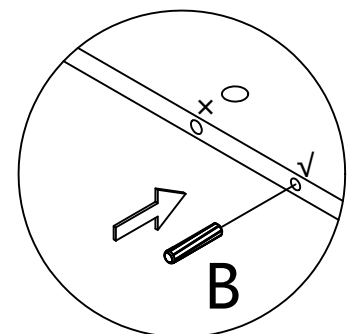
**B**

2

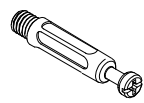

A1 x 12

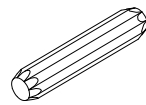

B x 8



C x 8

3.5 x 14mm

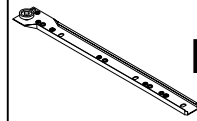

H1CL x 1

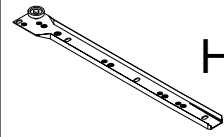

H1CR x 3

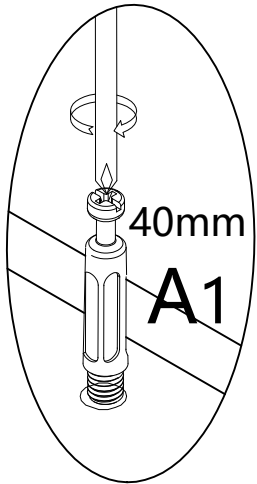

40mm

A1

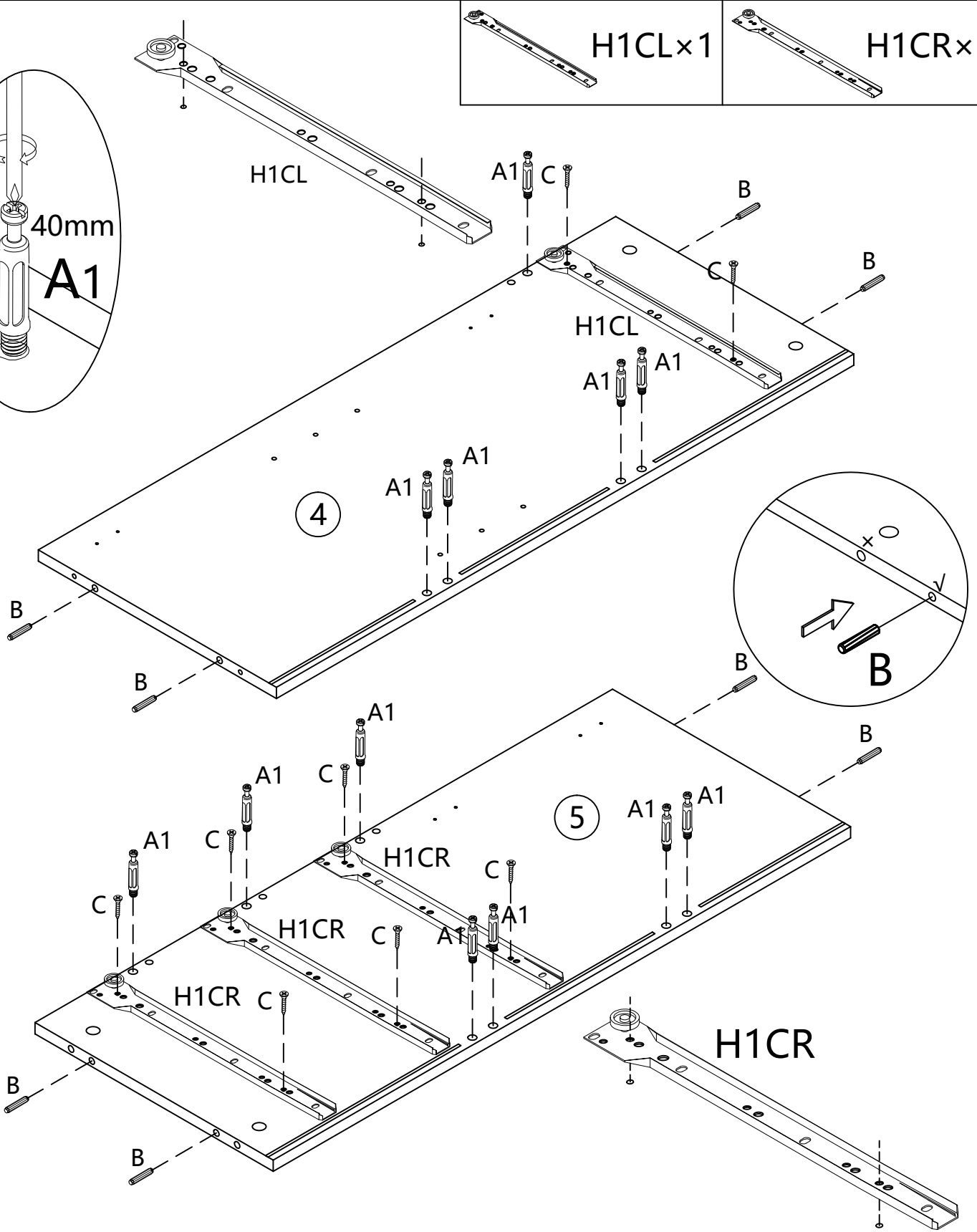

3

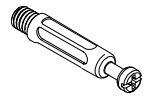

A1×20



B×12

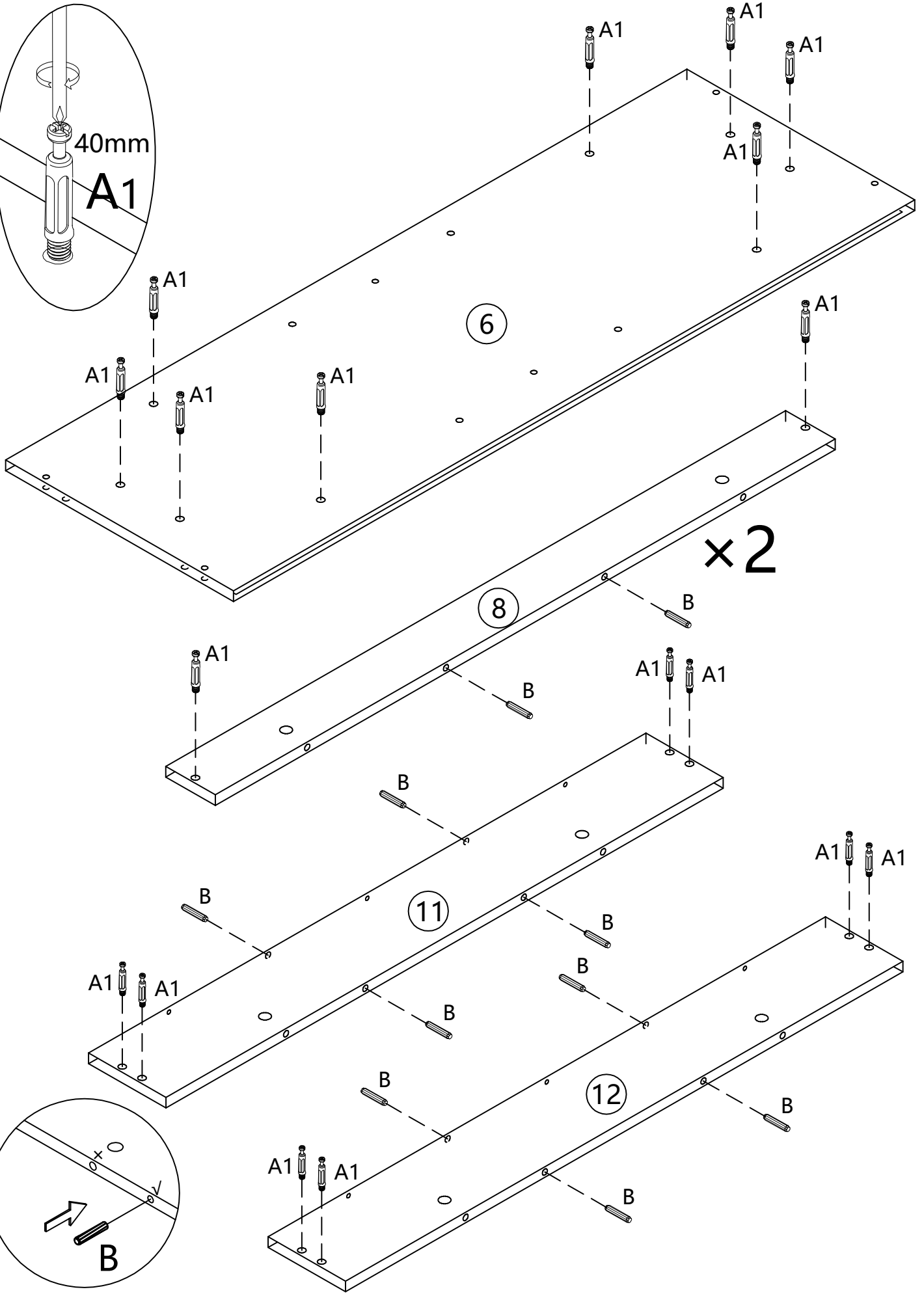
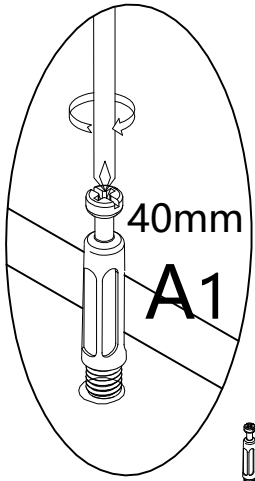

4



A1×28

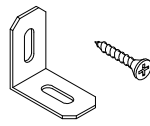

M×2

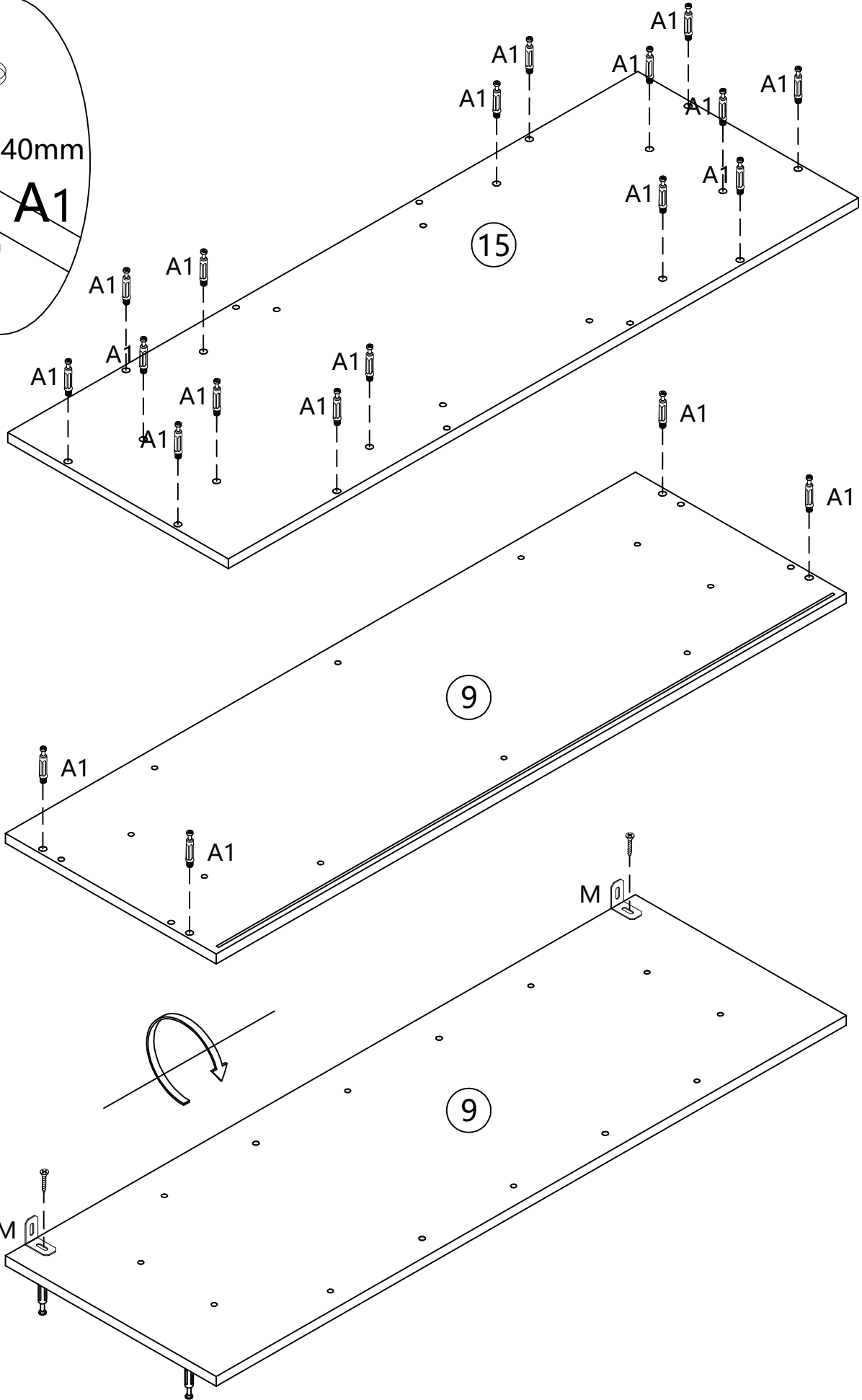
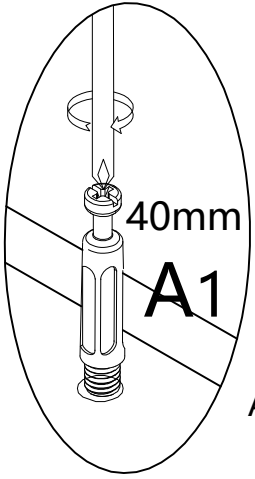

5

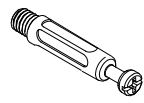

A1×4

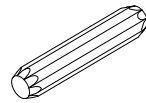

B×4



C×8  
3.5×14mm

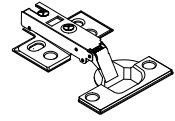

J×4

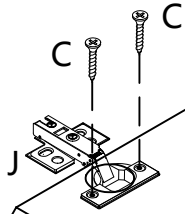
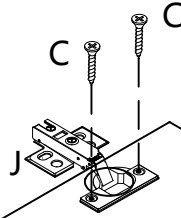
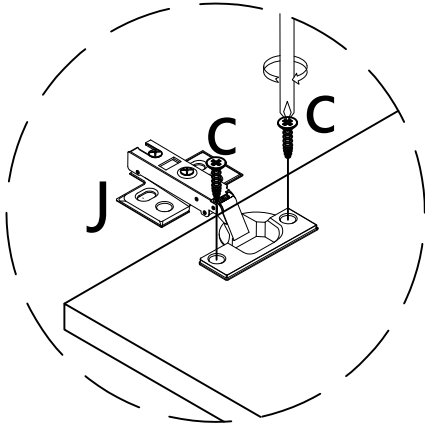

16

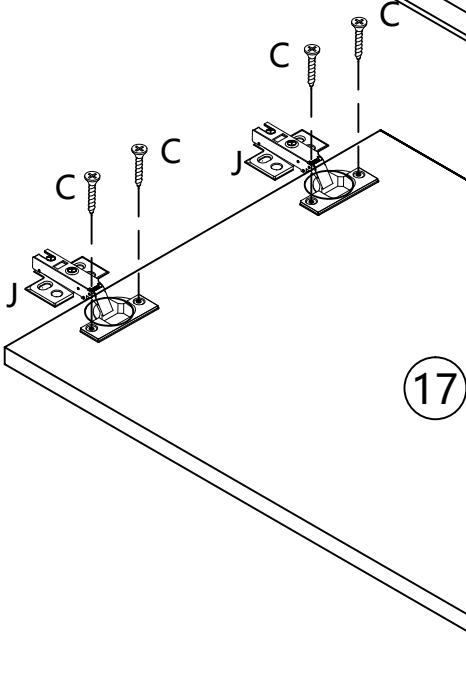

17

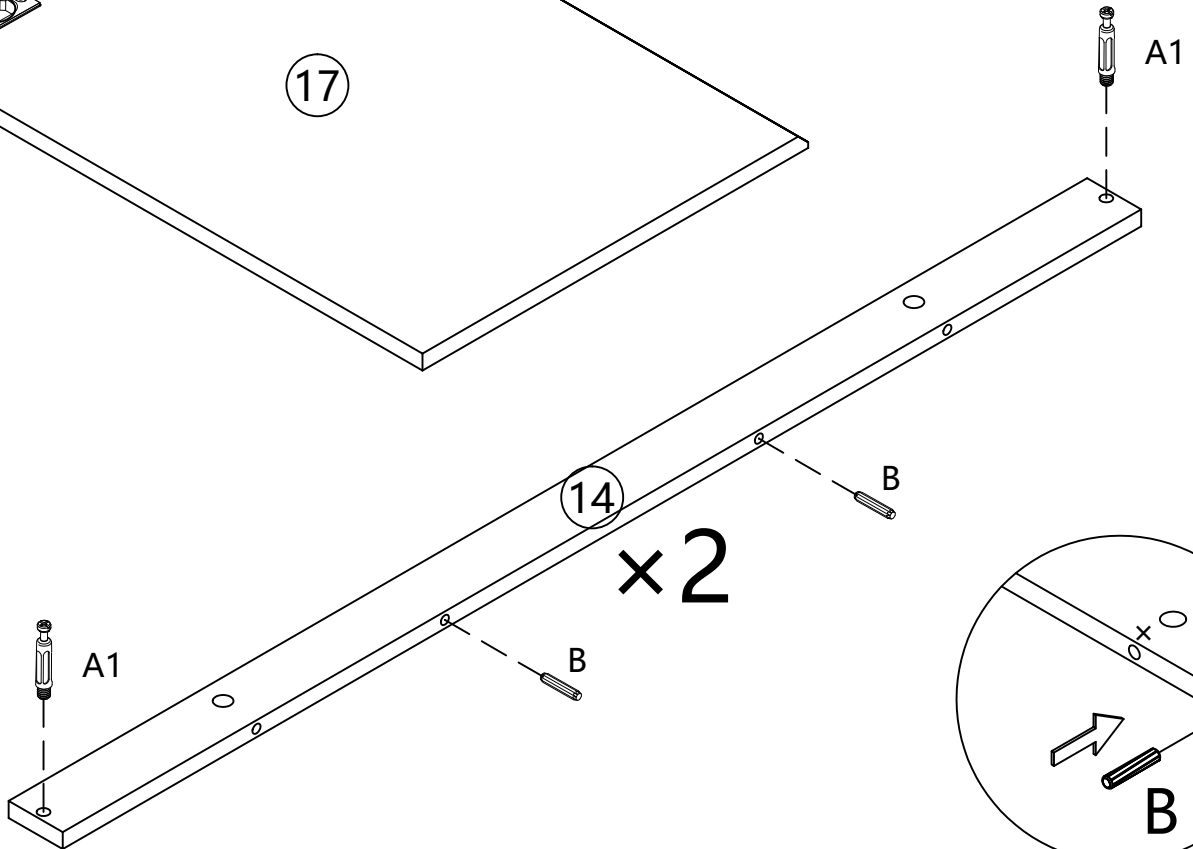

14

×2

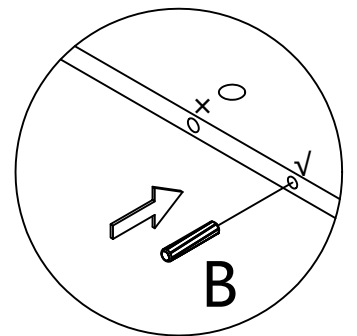

6



A2×1

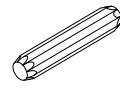

B×1

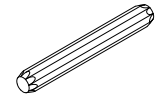

F×1

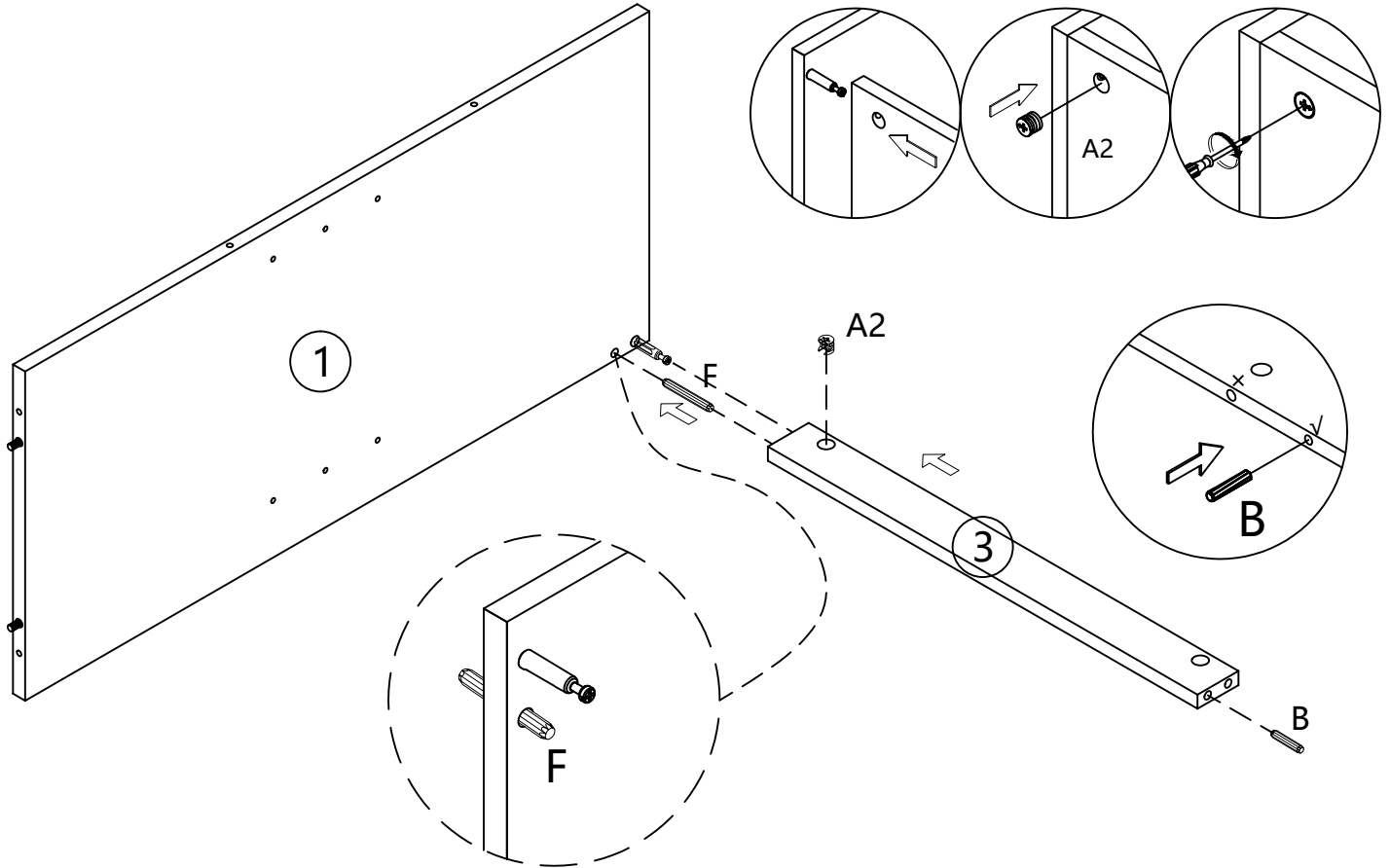

7



A2×3

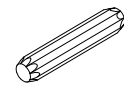

B×5

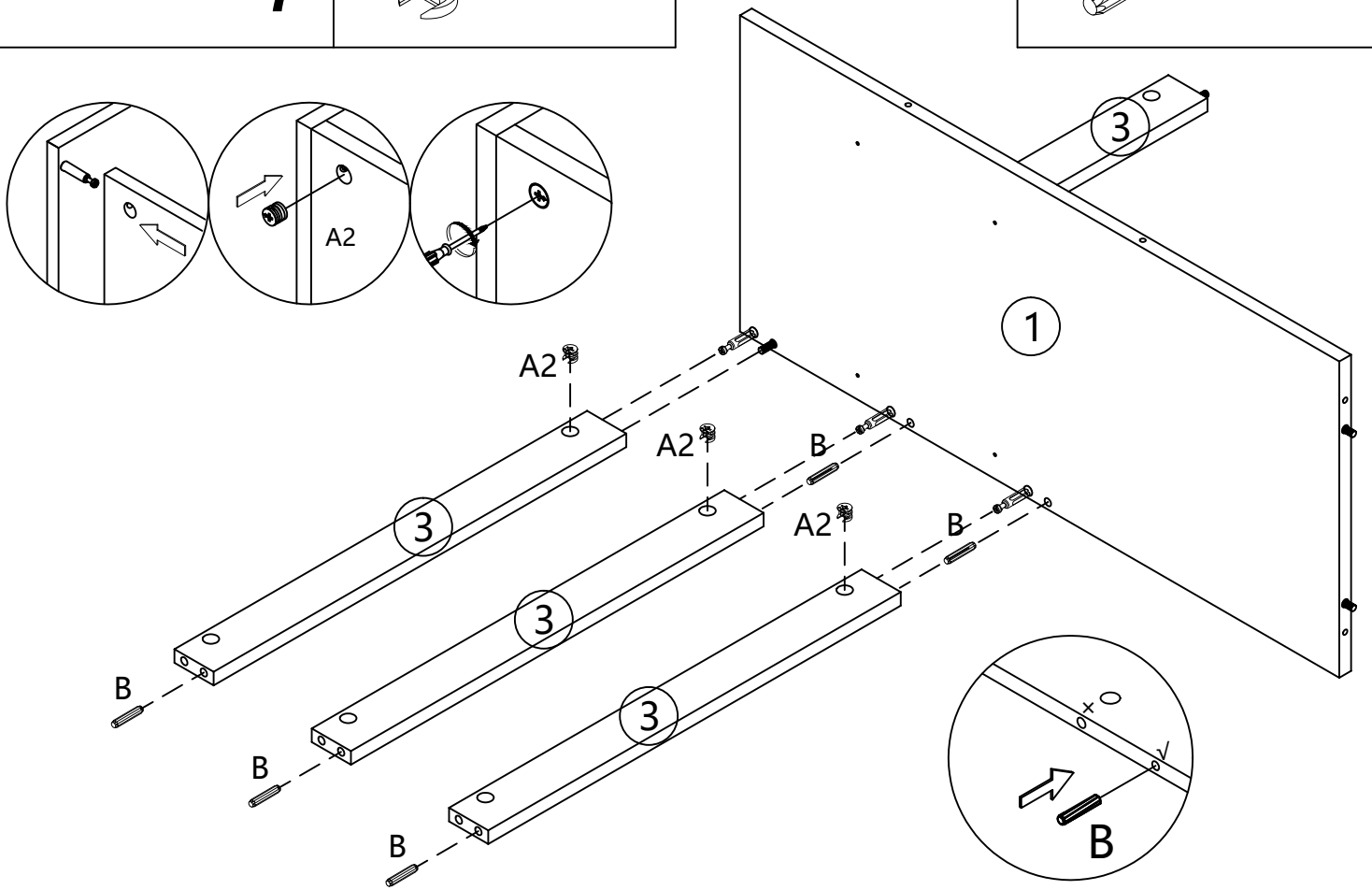

8



A2x7

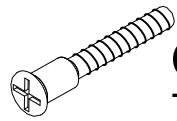

Gx2  
7x50mm

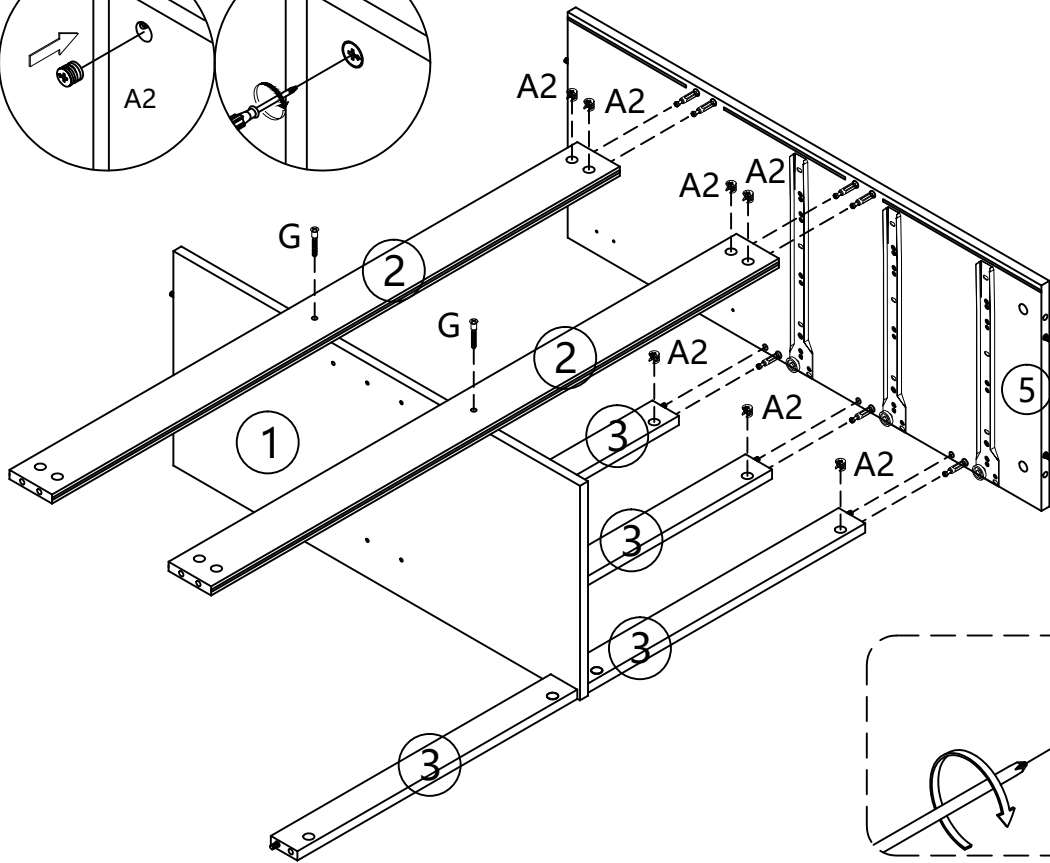
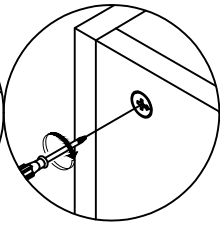
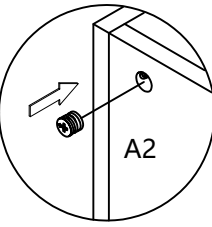
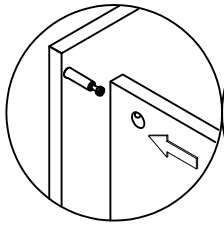

9

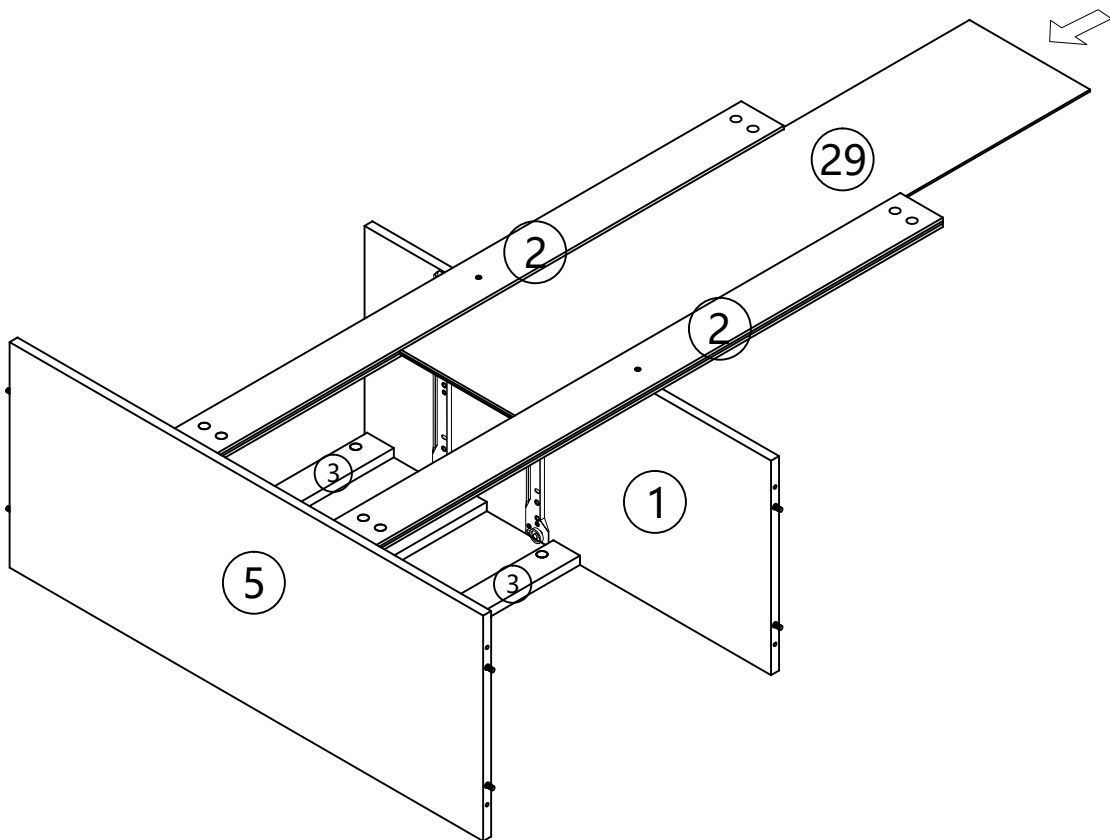

10



A2x5

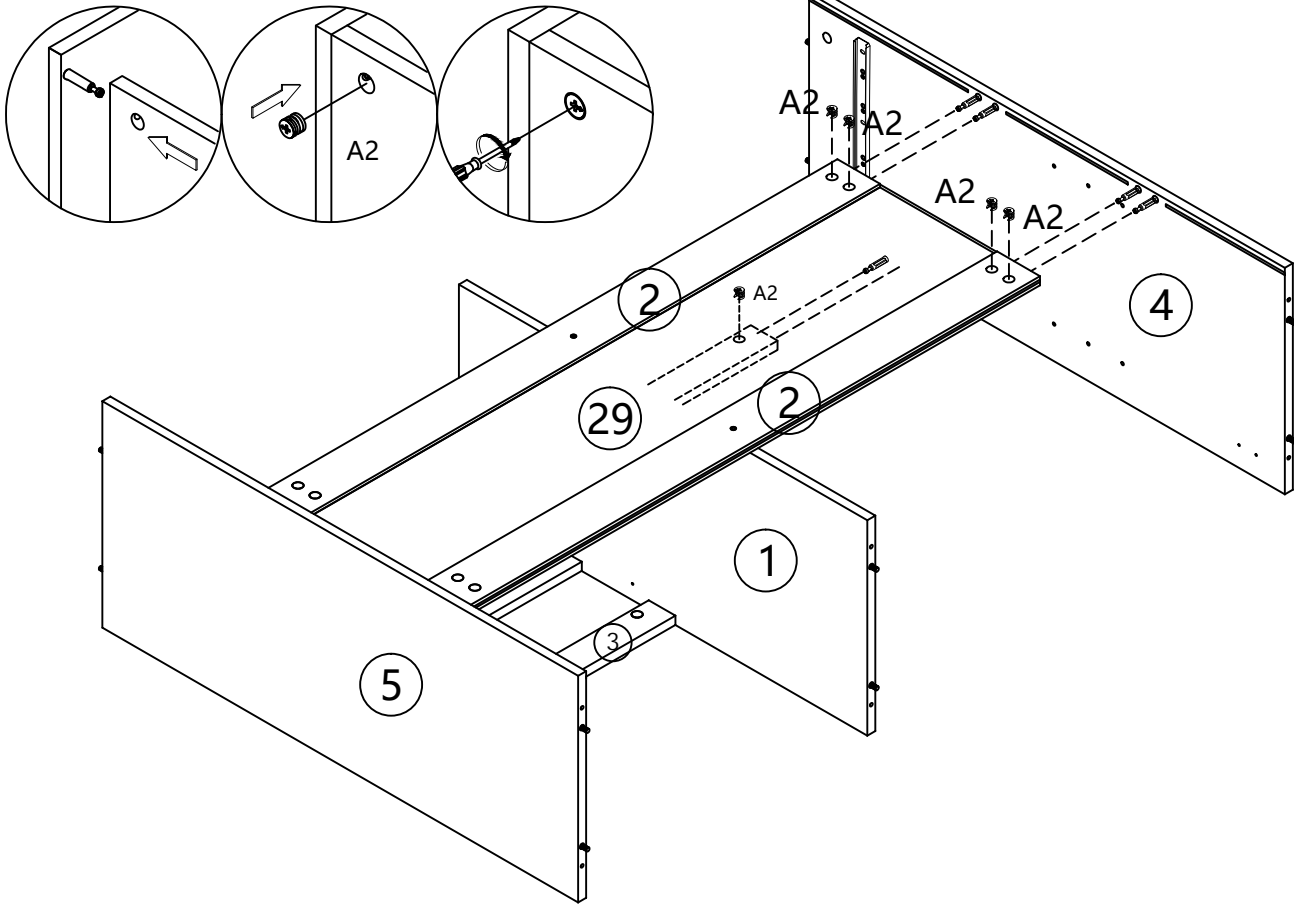

11

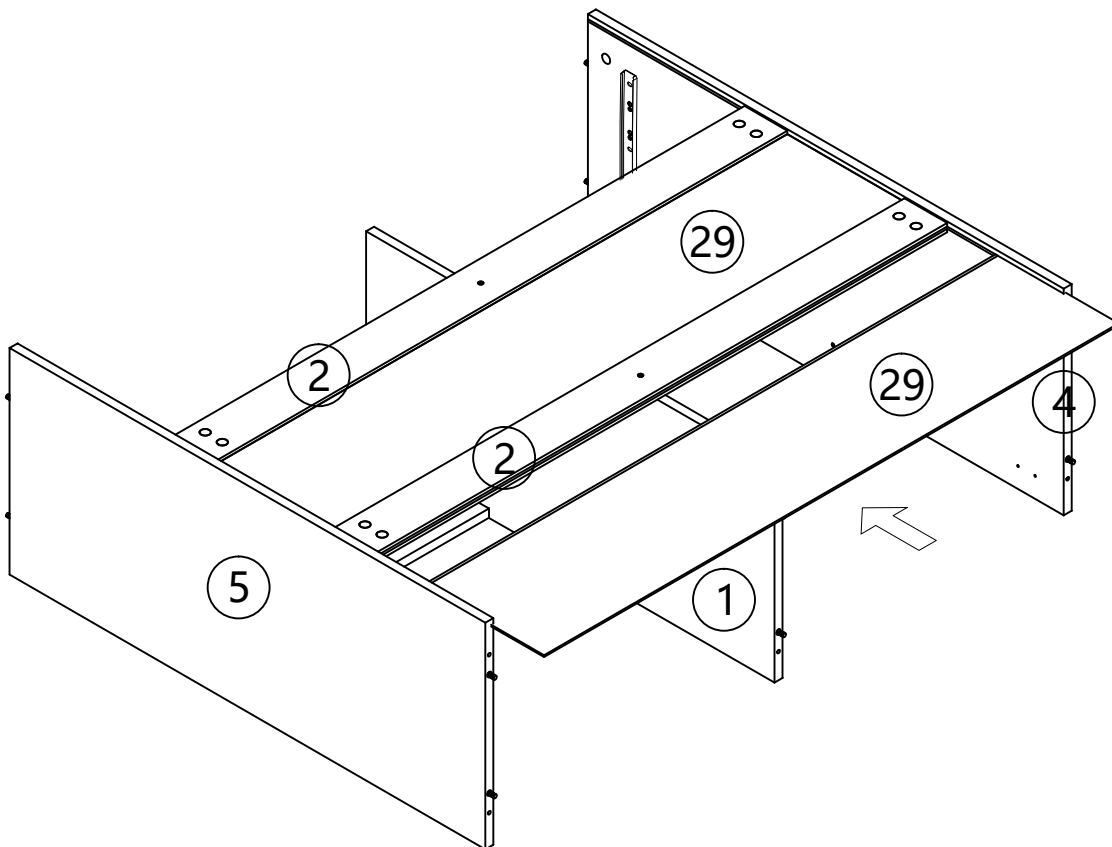

12

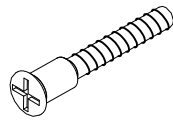

G×6  
7x50mm

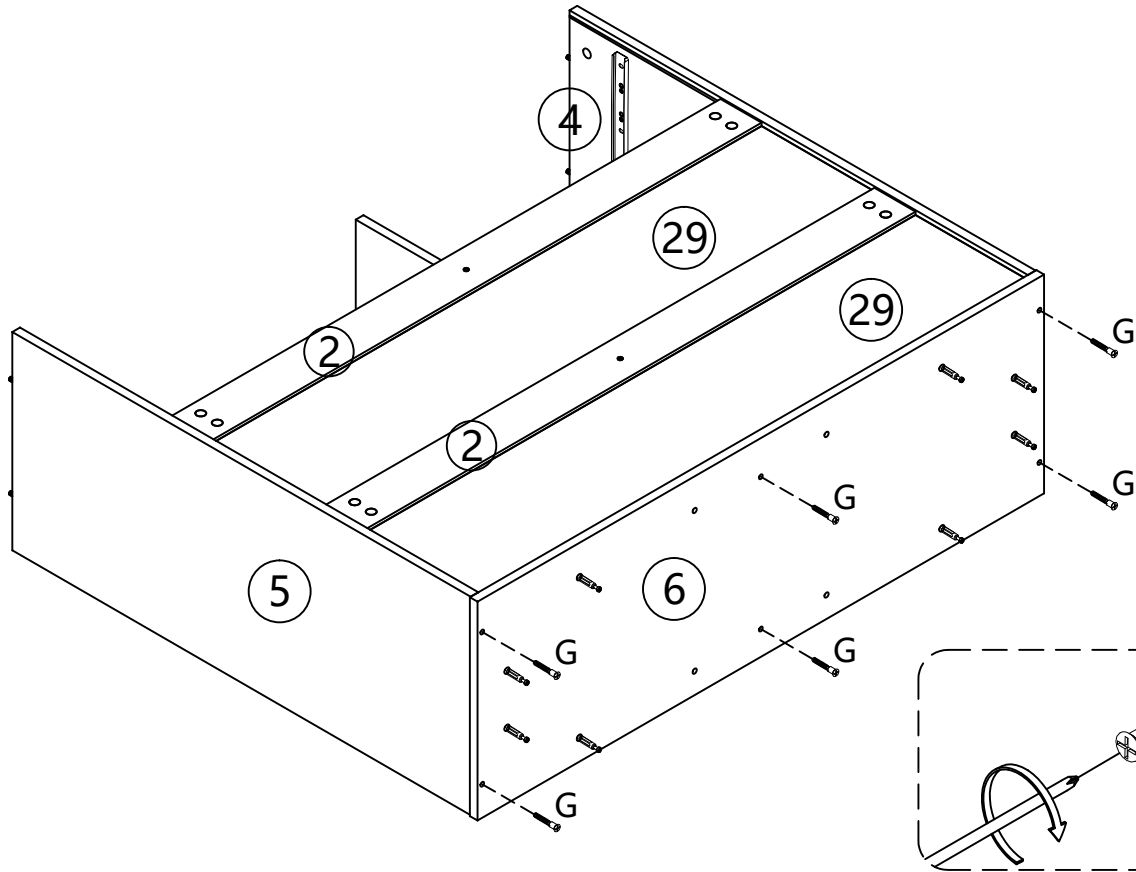

13



A2×4

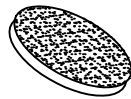

N×8

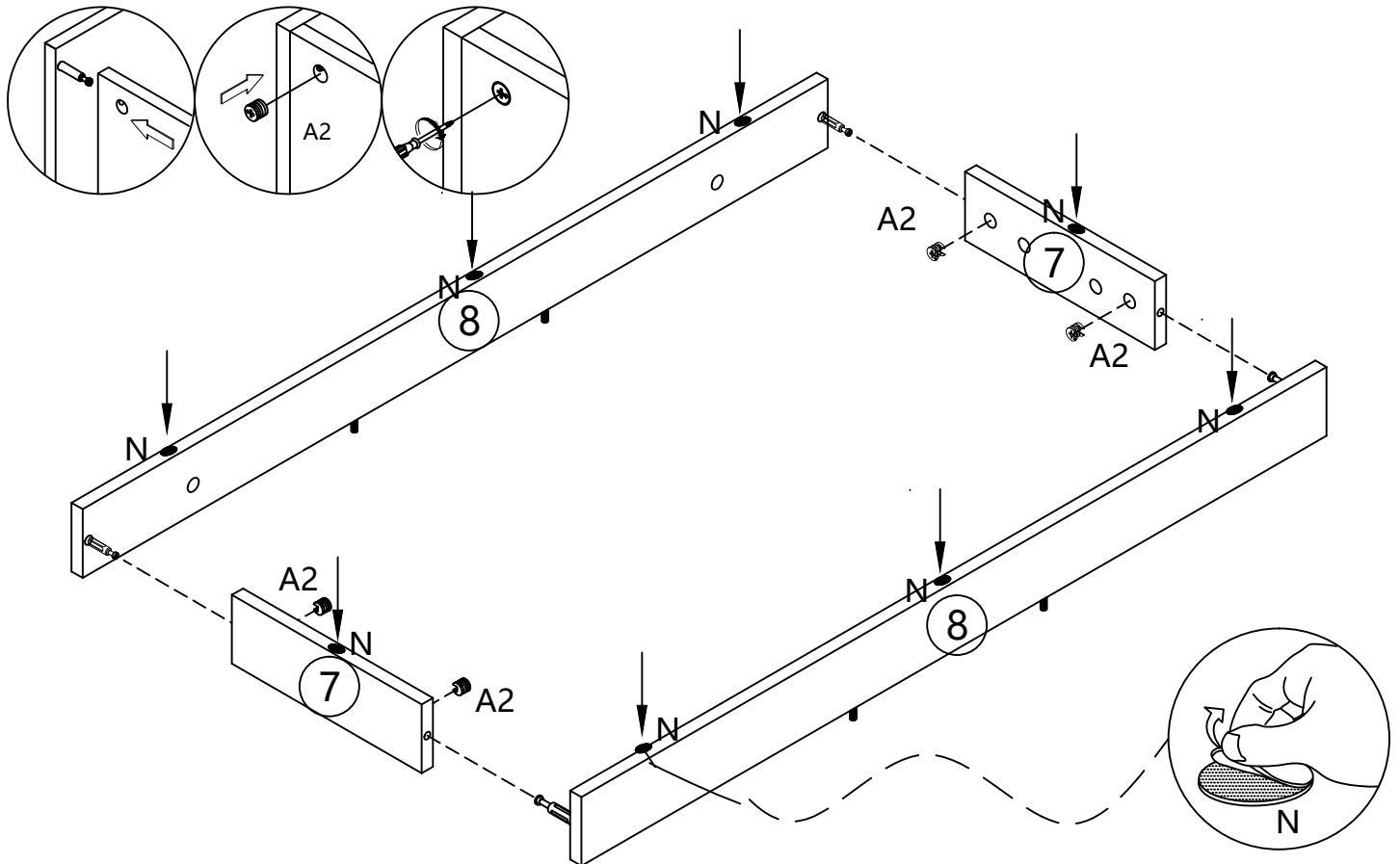

14



A2x8

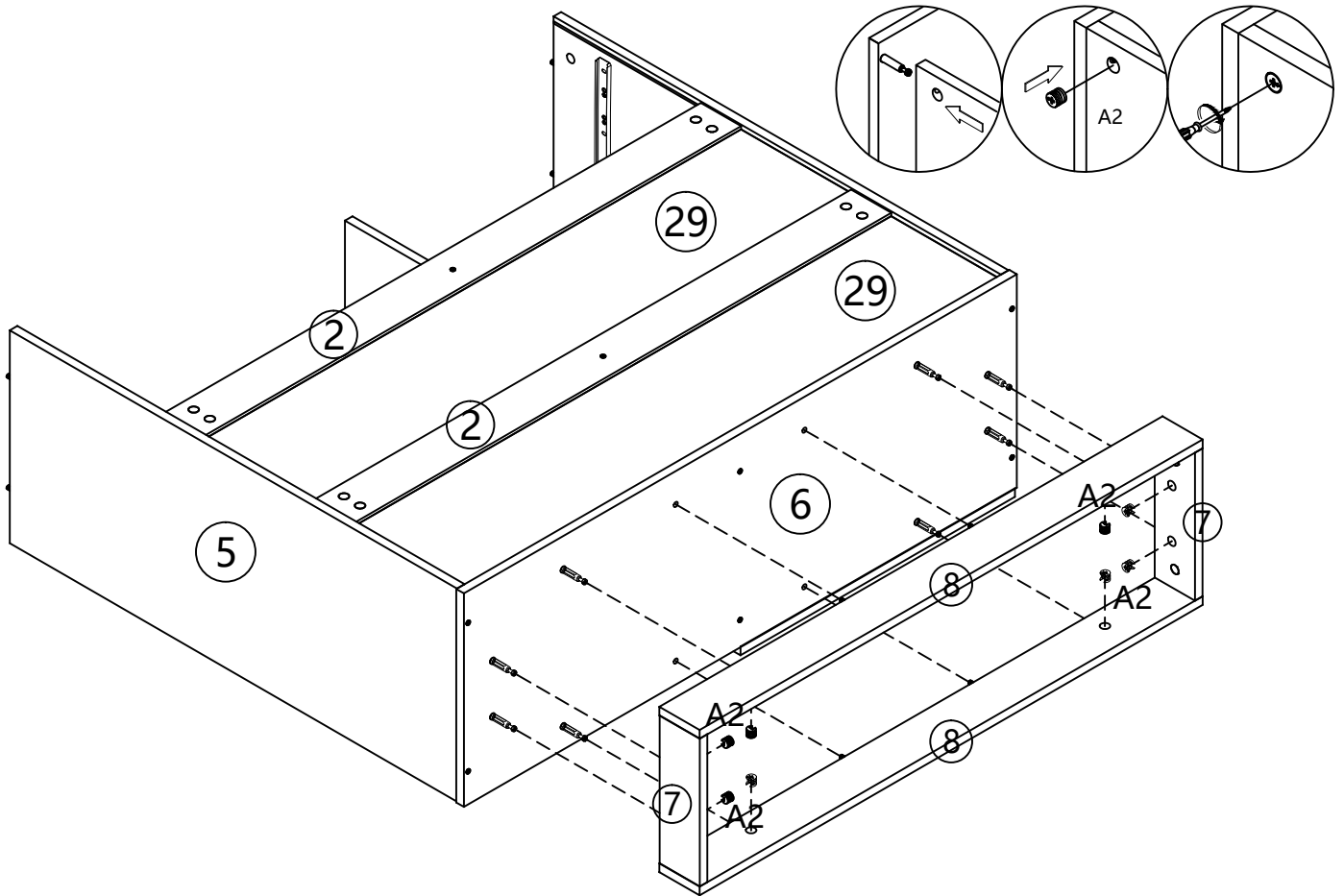

15



A2x4

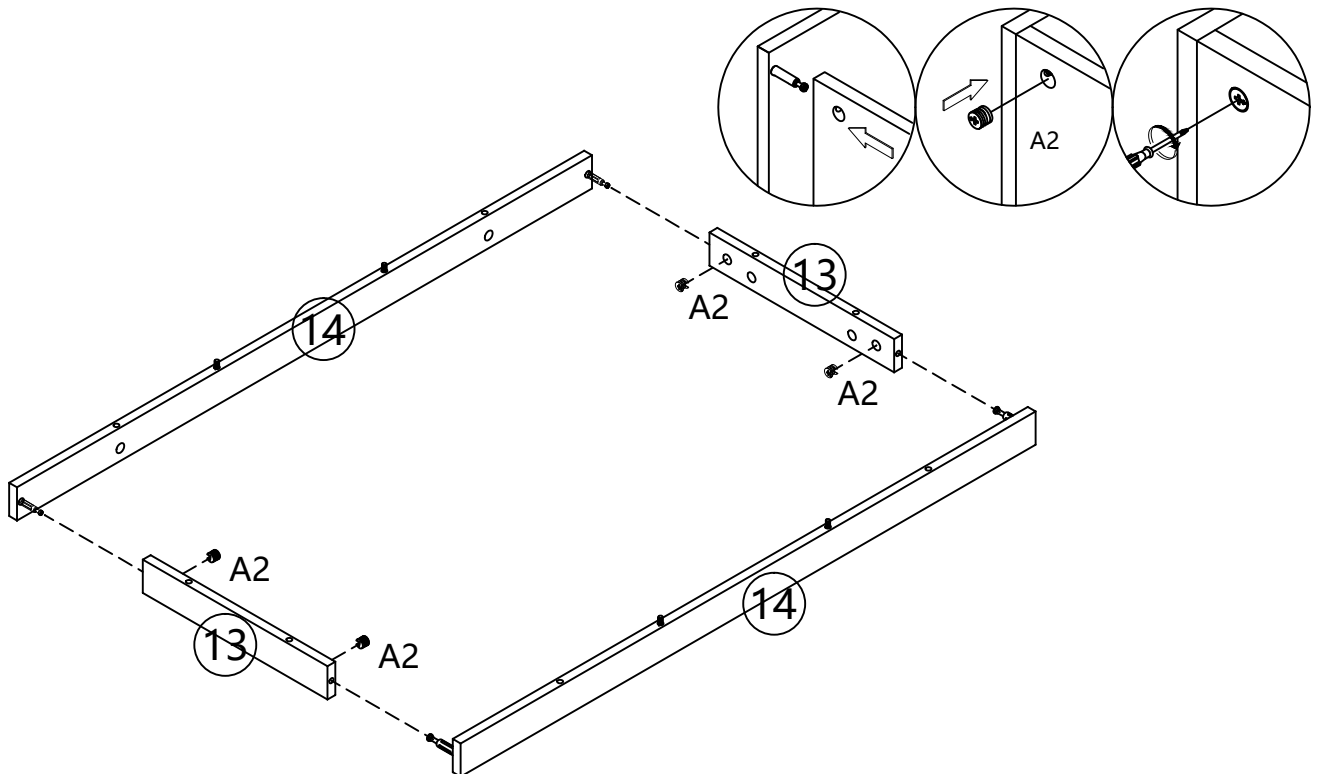

16

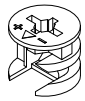

A2x8

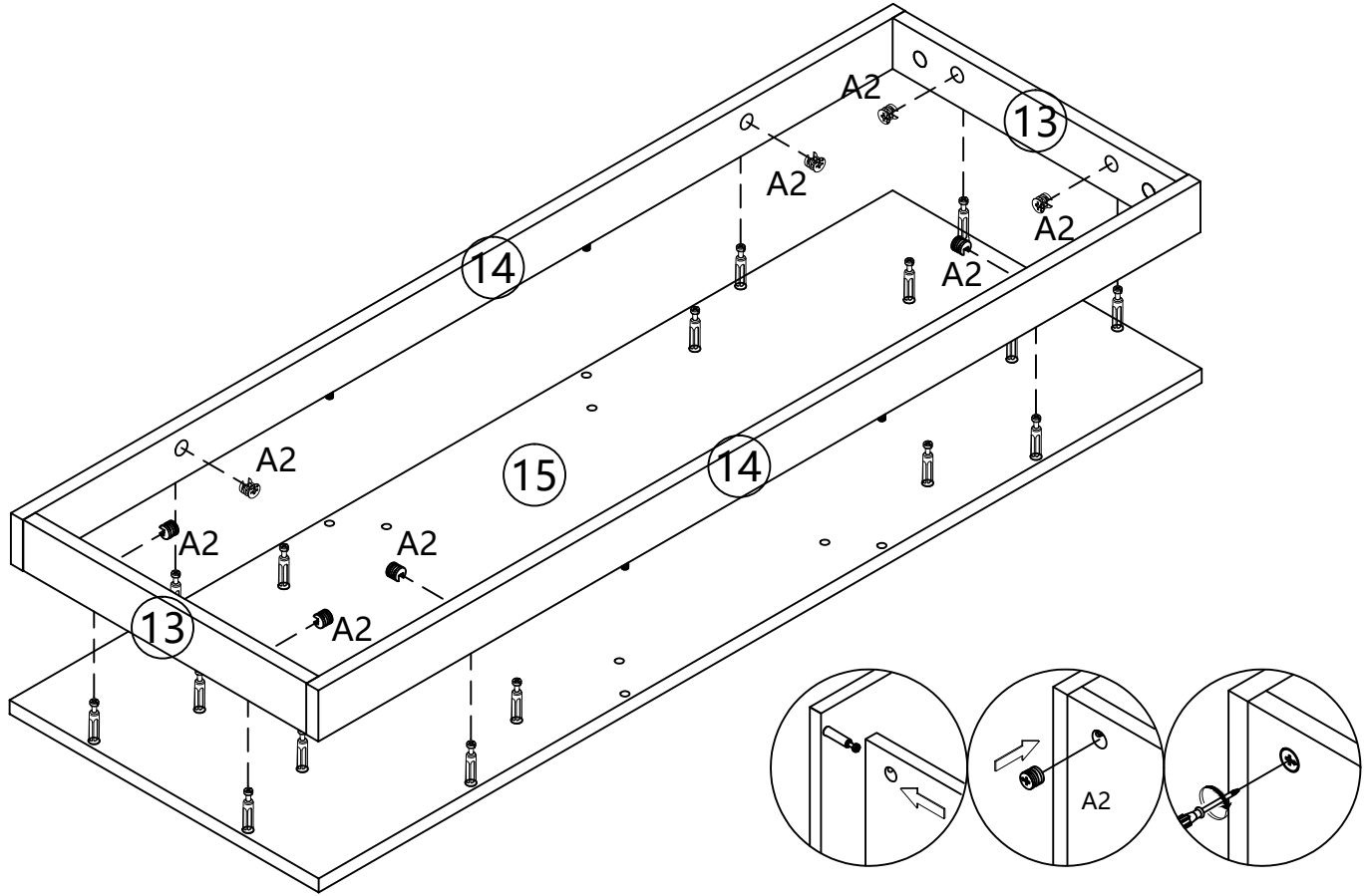

17

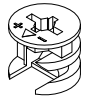

A2x8

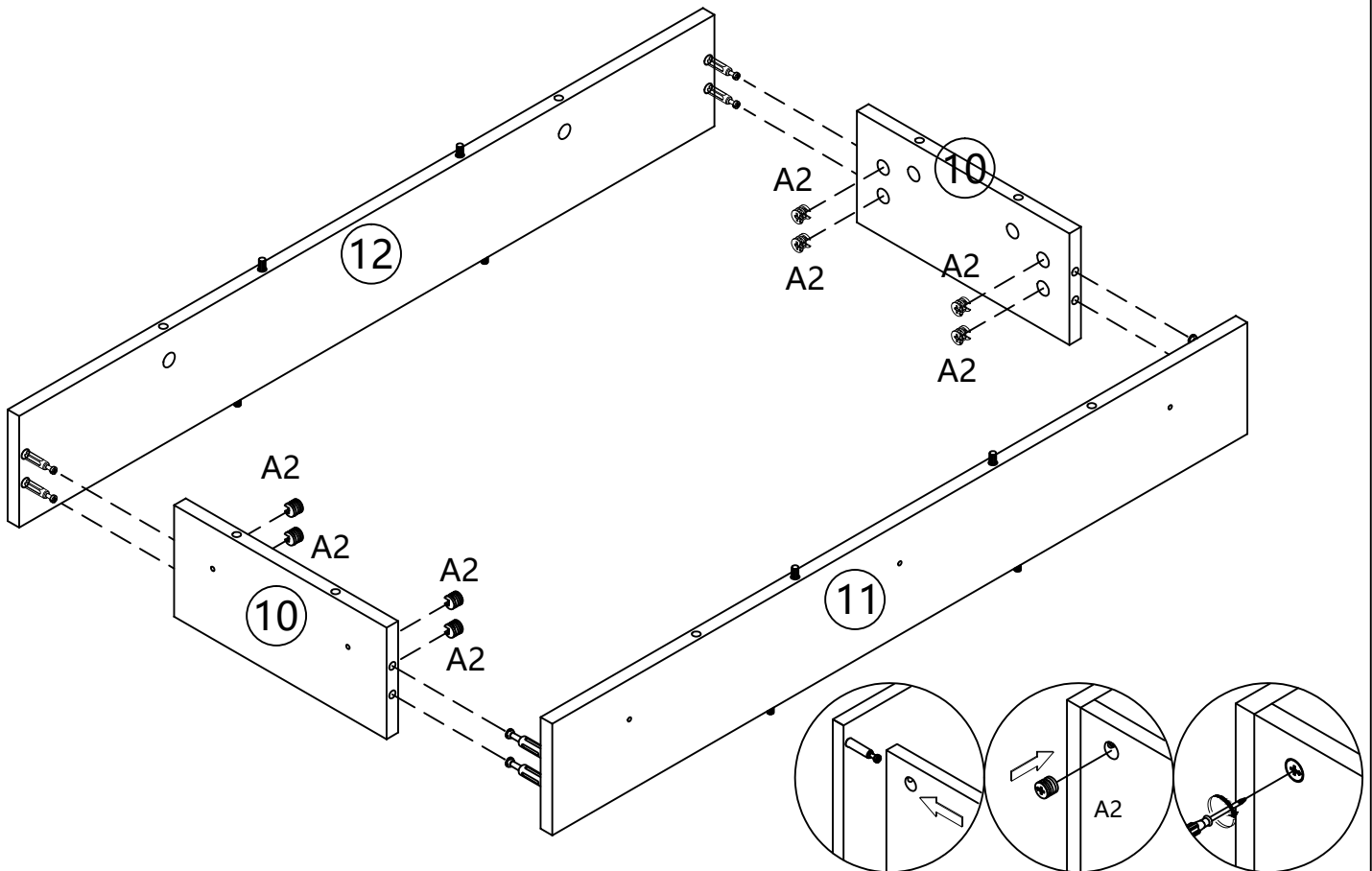

18

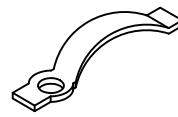
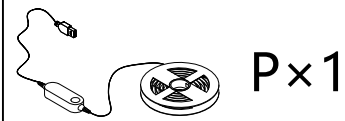

R×7  
3×12mm

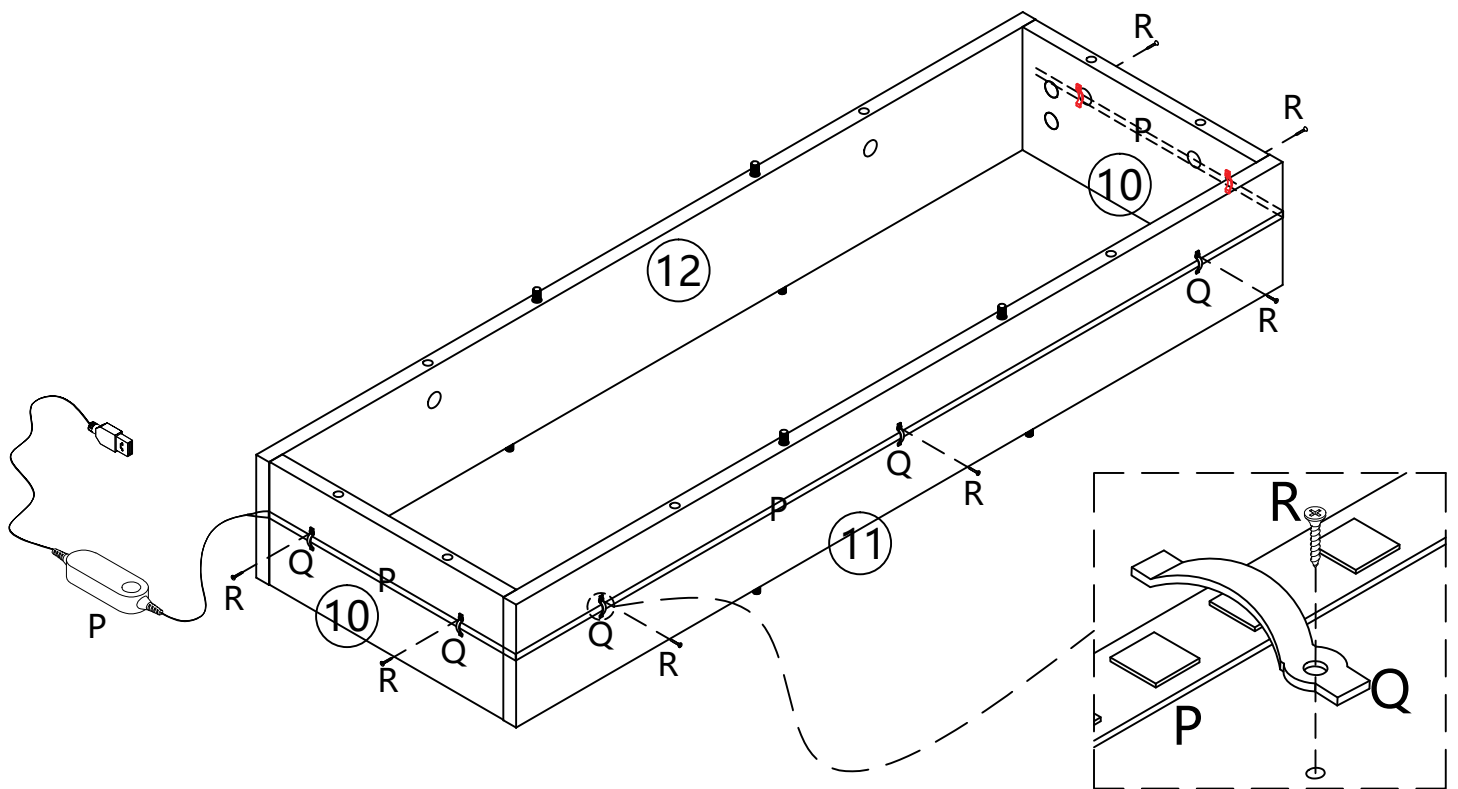

19



A2×8

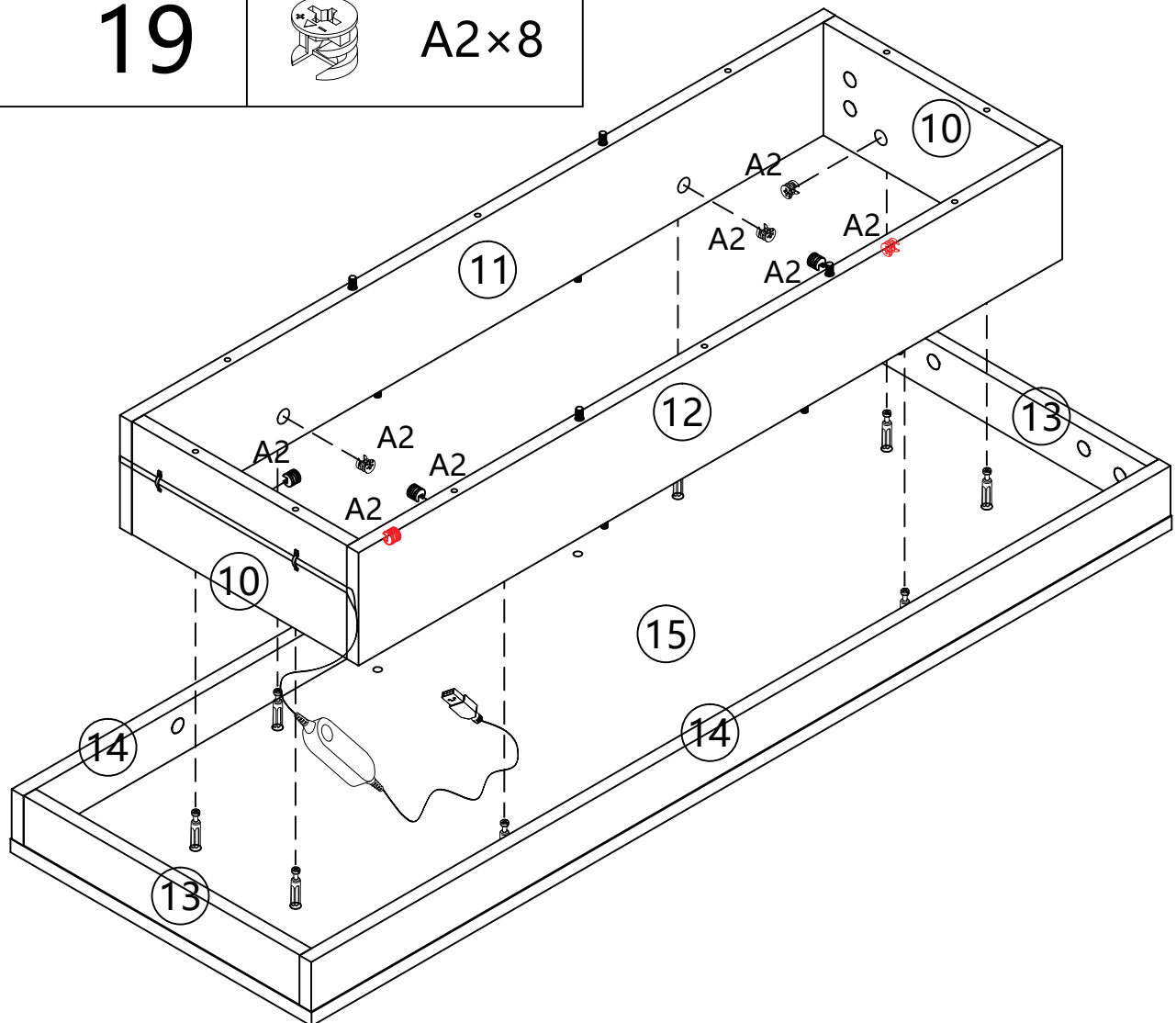

20

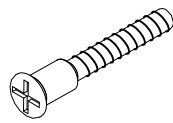

G×10  
7x50mm

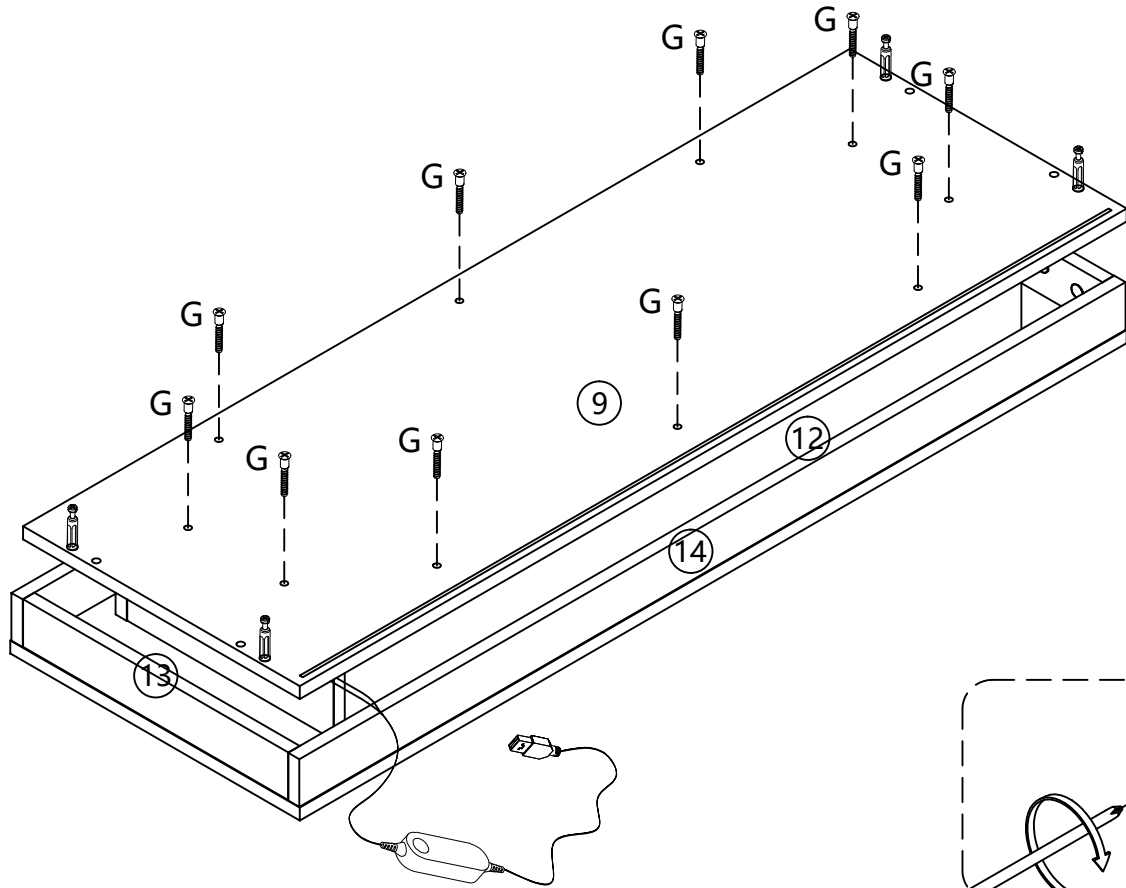

21

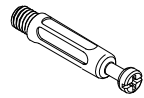

A1×2

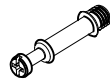

E1×12

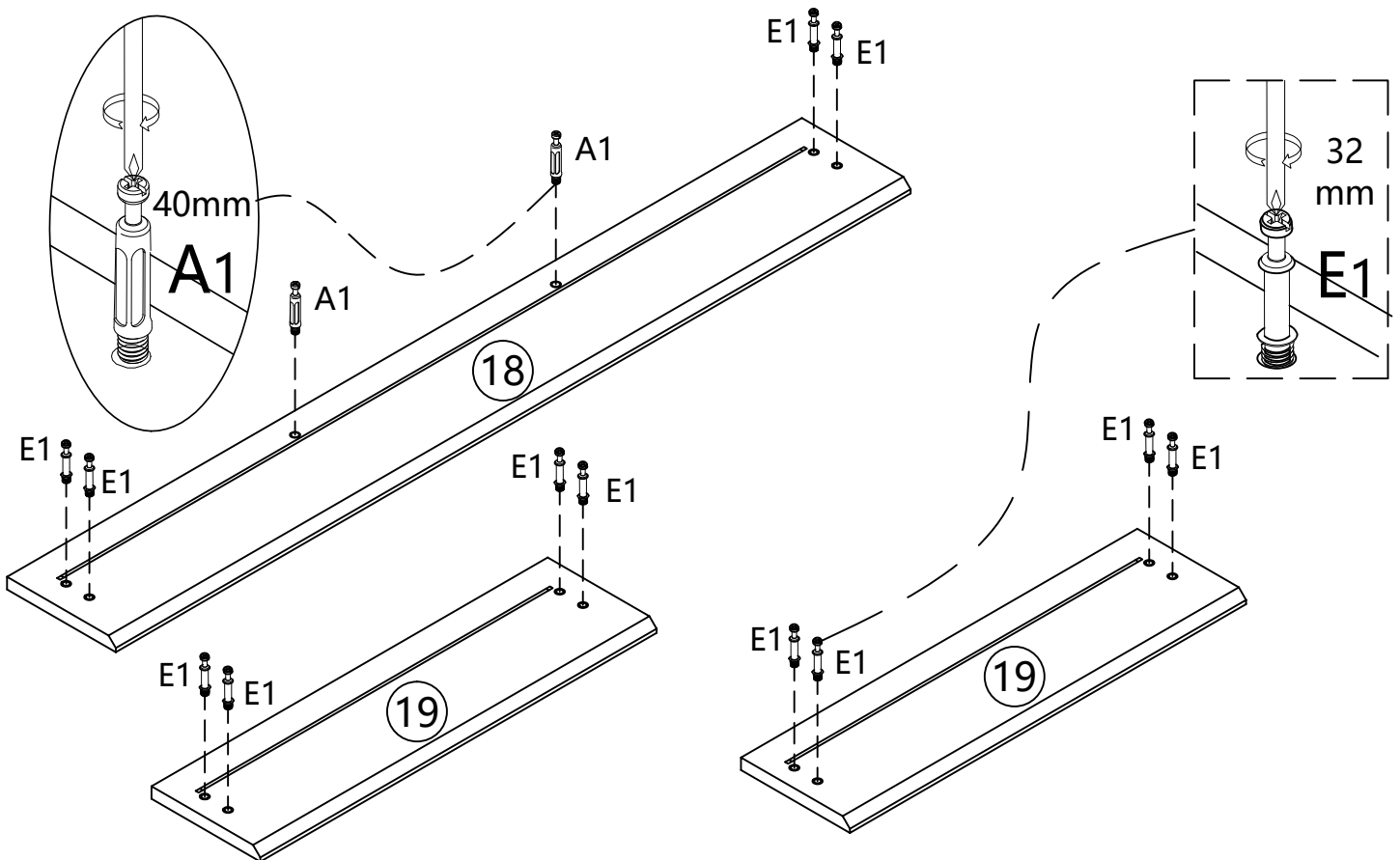

22



A2×4

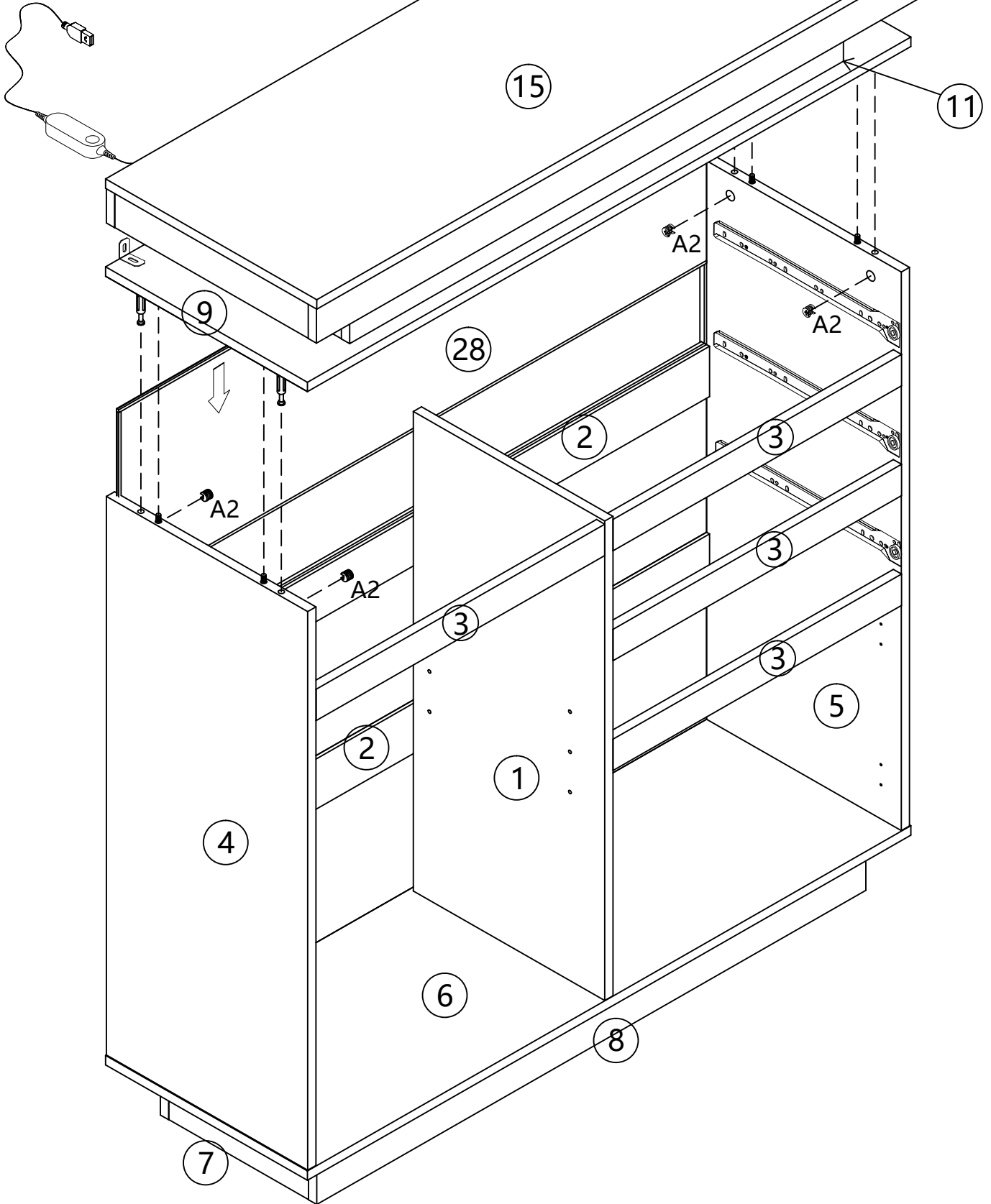
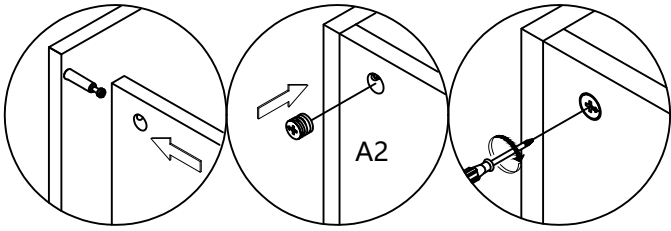

23

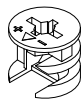

A2×2

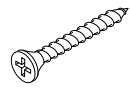

D×8  
3.5×35mm



E2×4

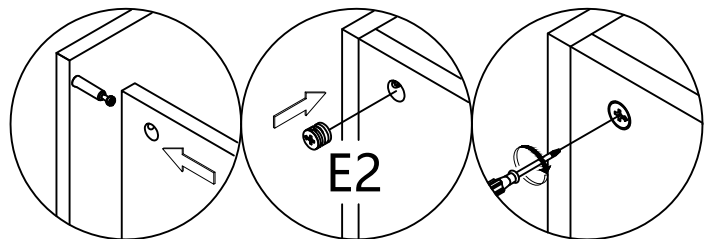
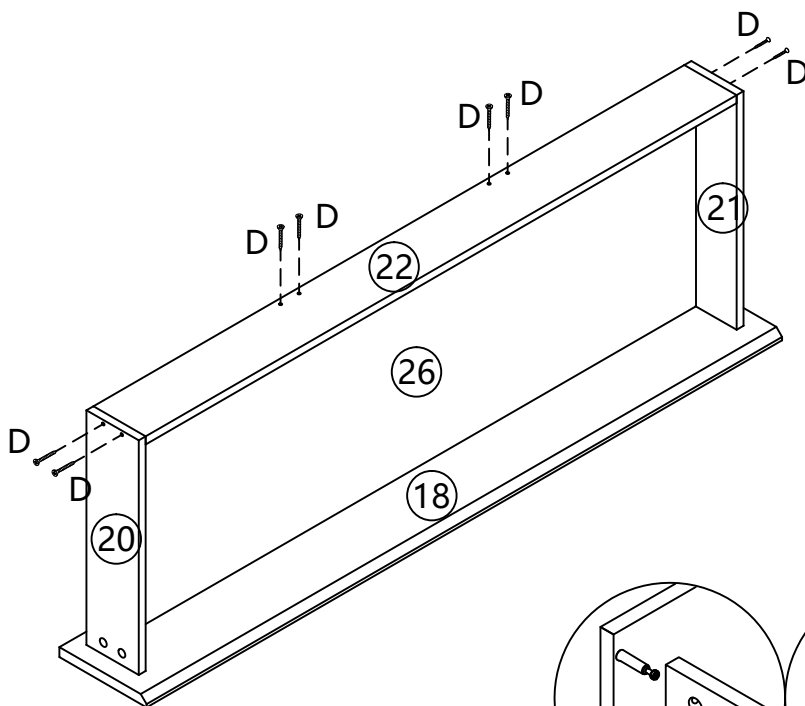
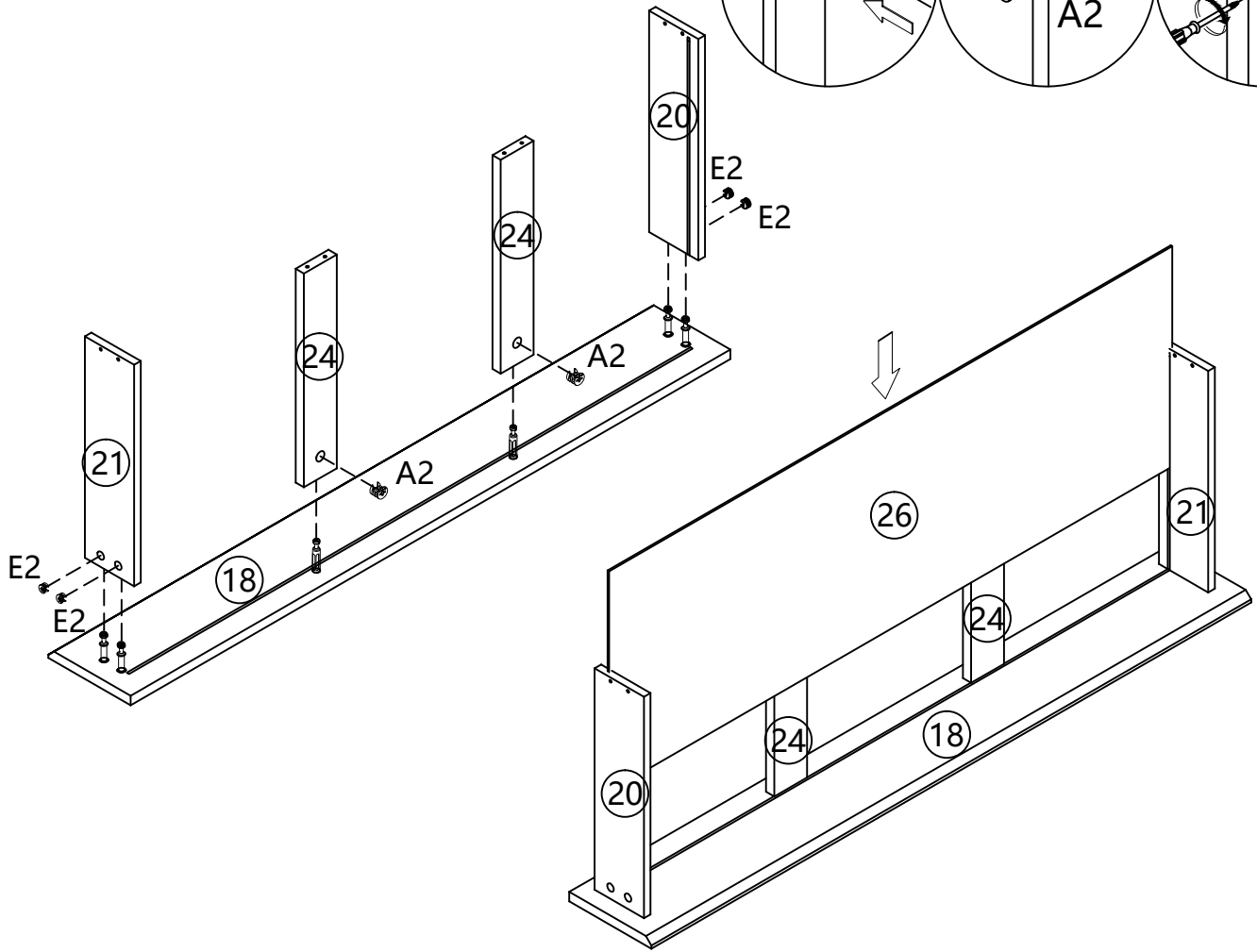
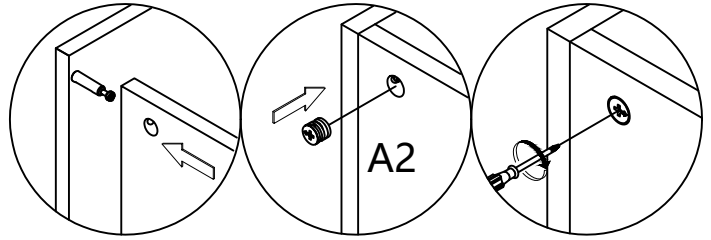

24



C×4  
3.5×14mm

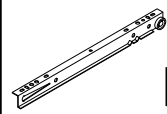

H2DL×1

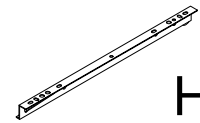

H2DR×1

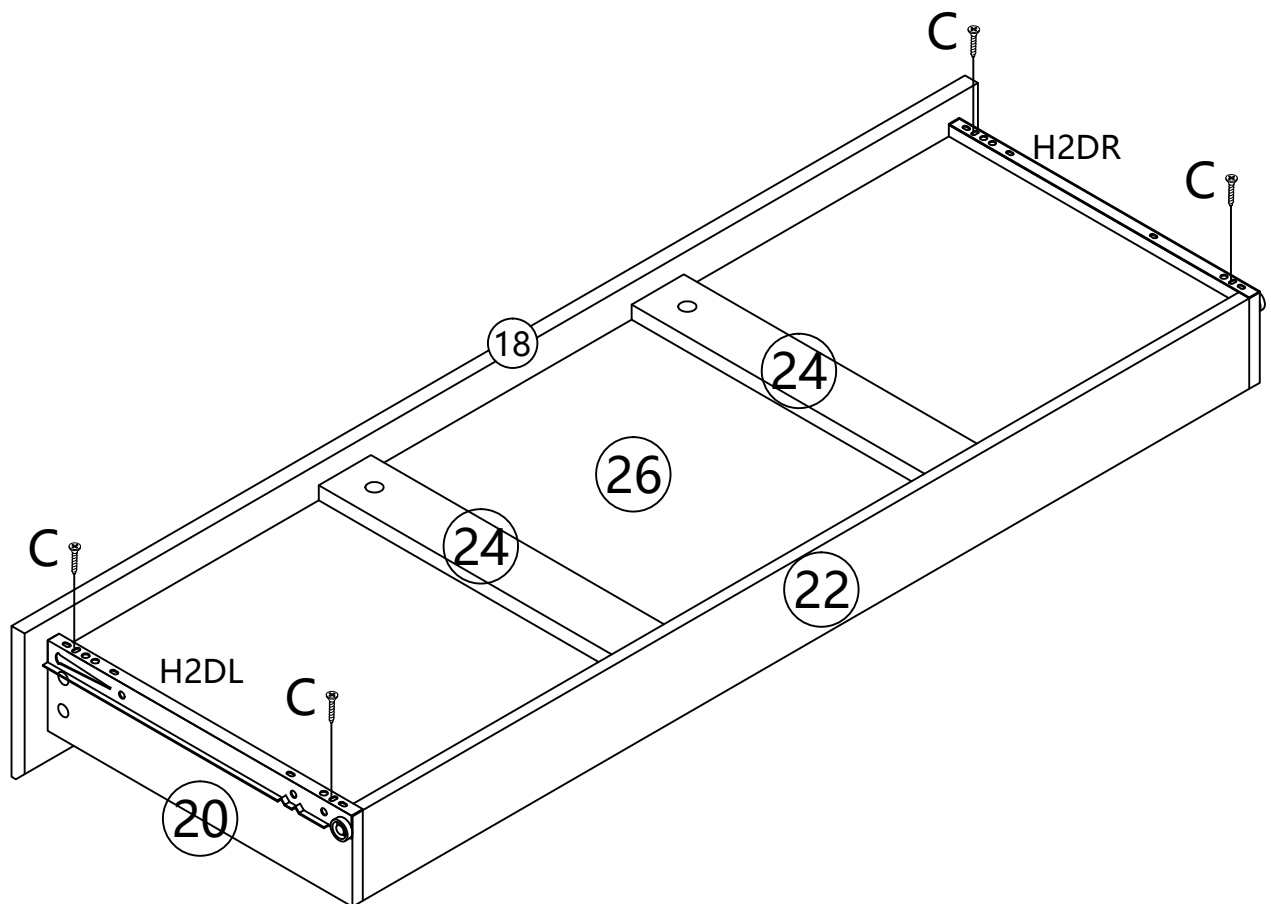
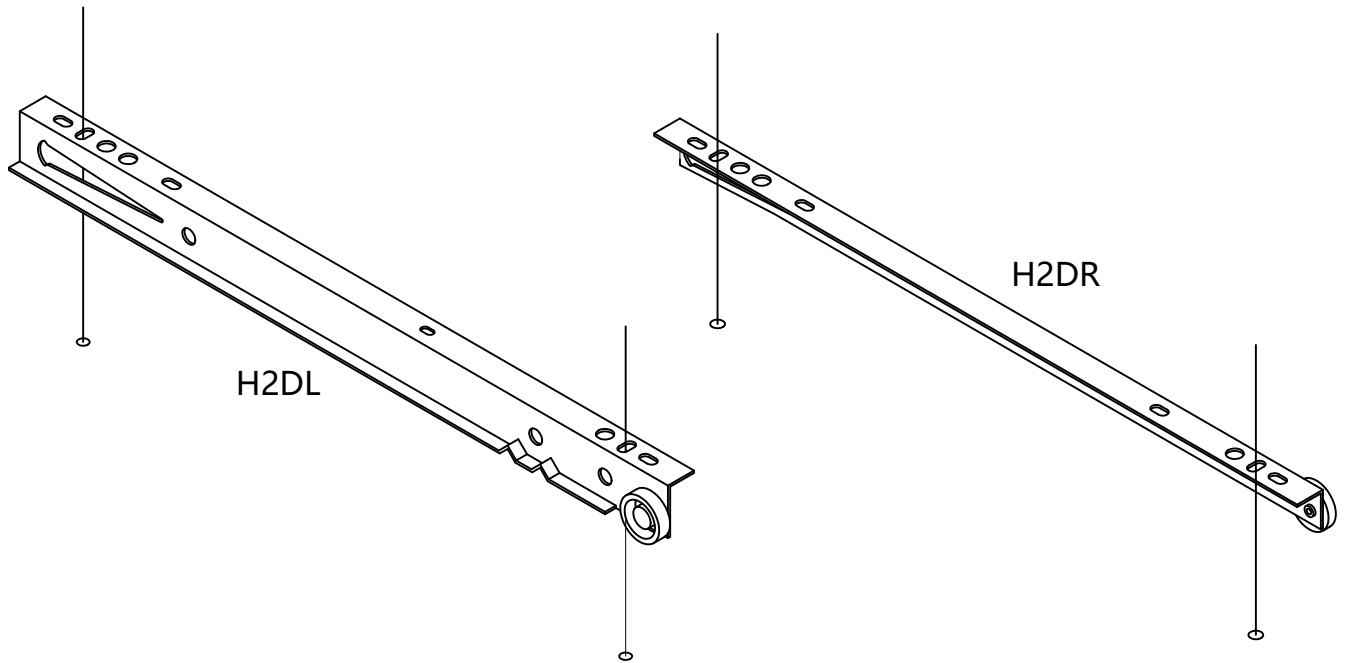

25

C×8  
3.5×14mm

D×8  
3.5×35mm

E2×8

H2DL×2

H2DR×2

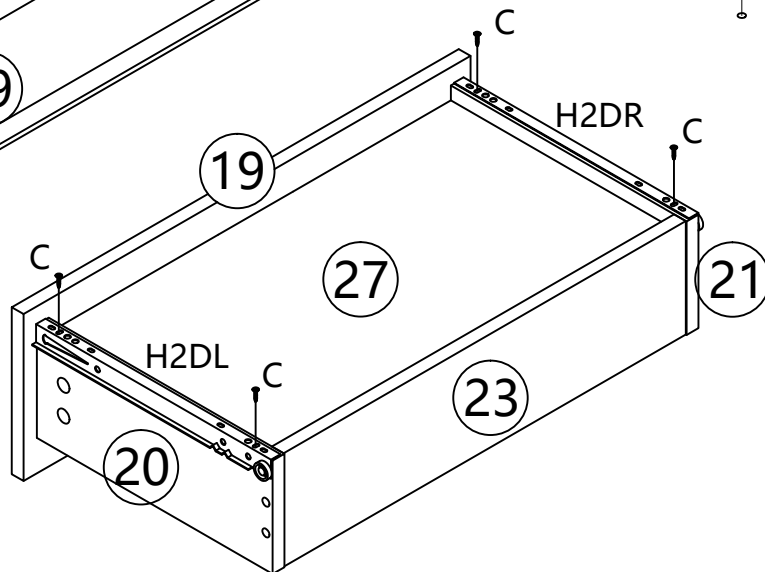
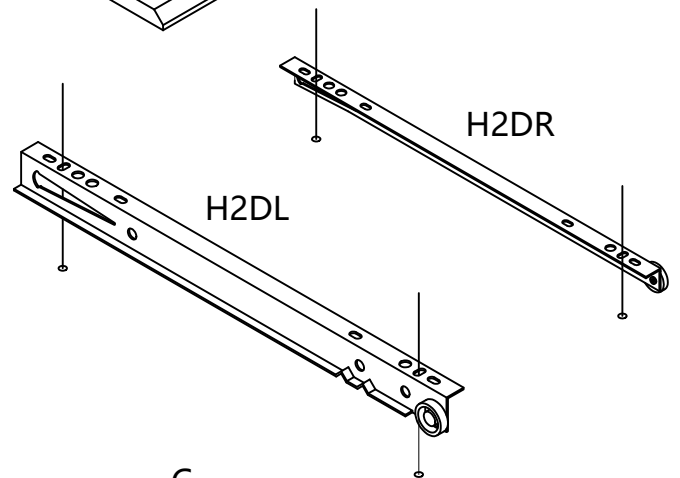
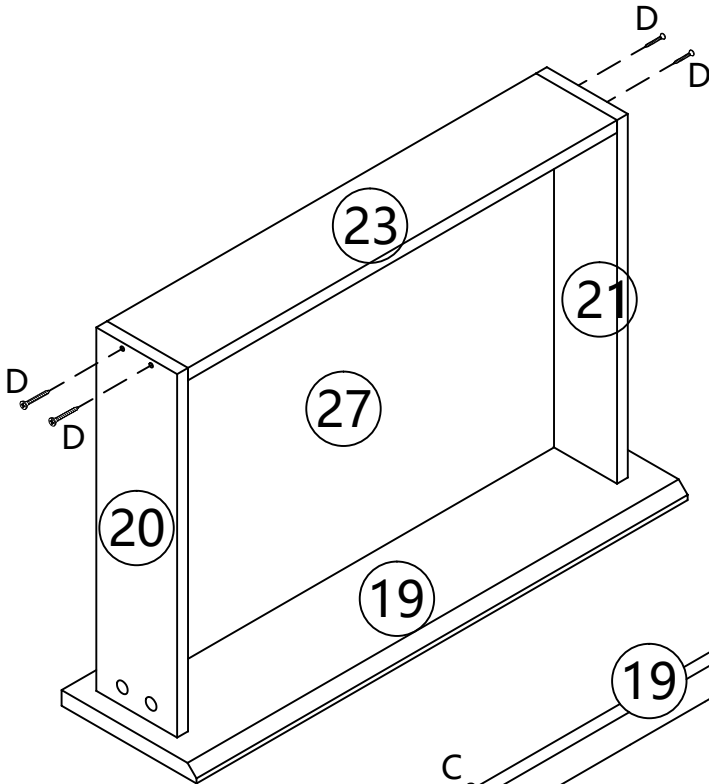
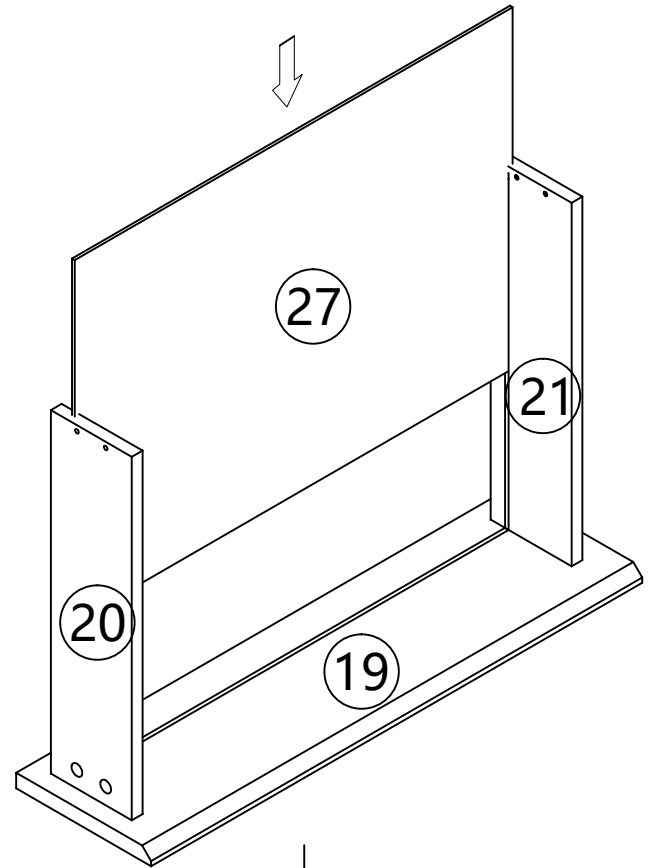
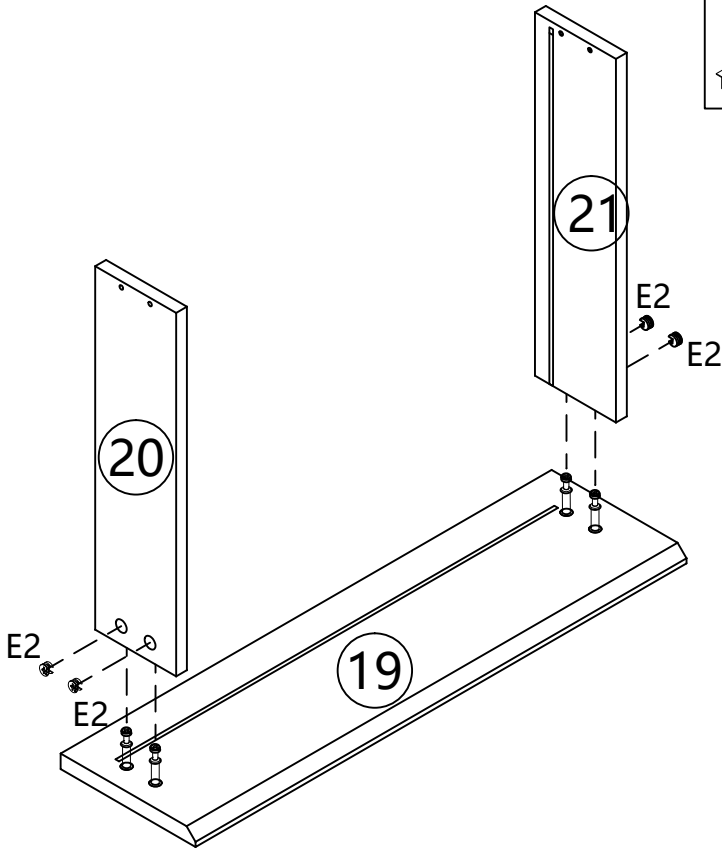

×2

26



L×4

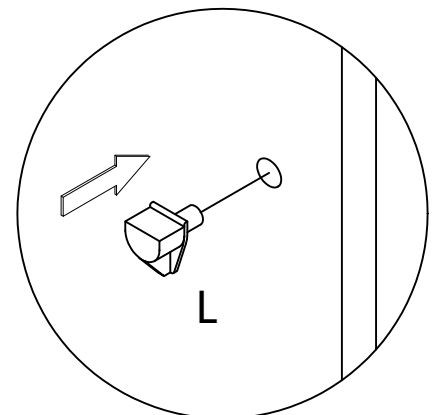
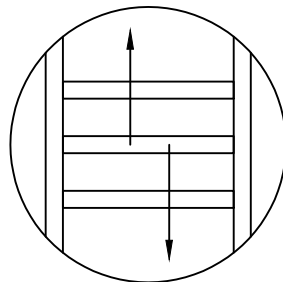
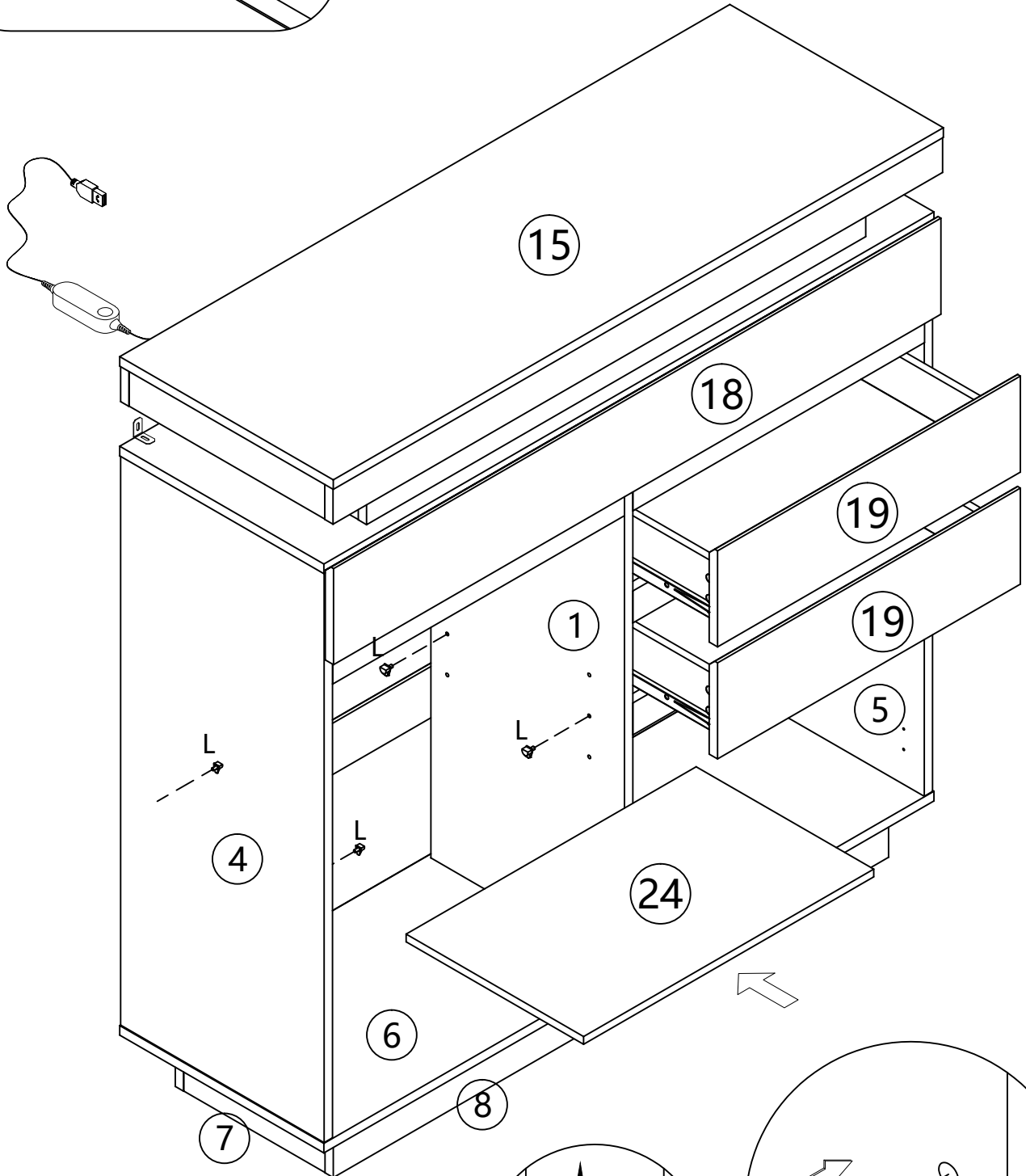
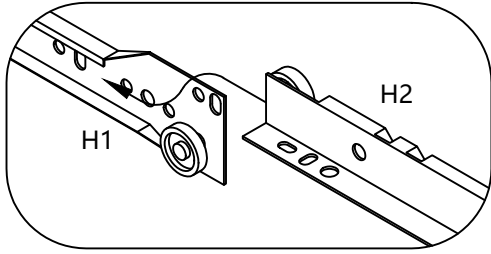

27



C×16  
3.5×14mm

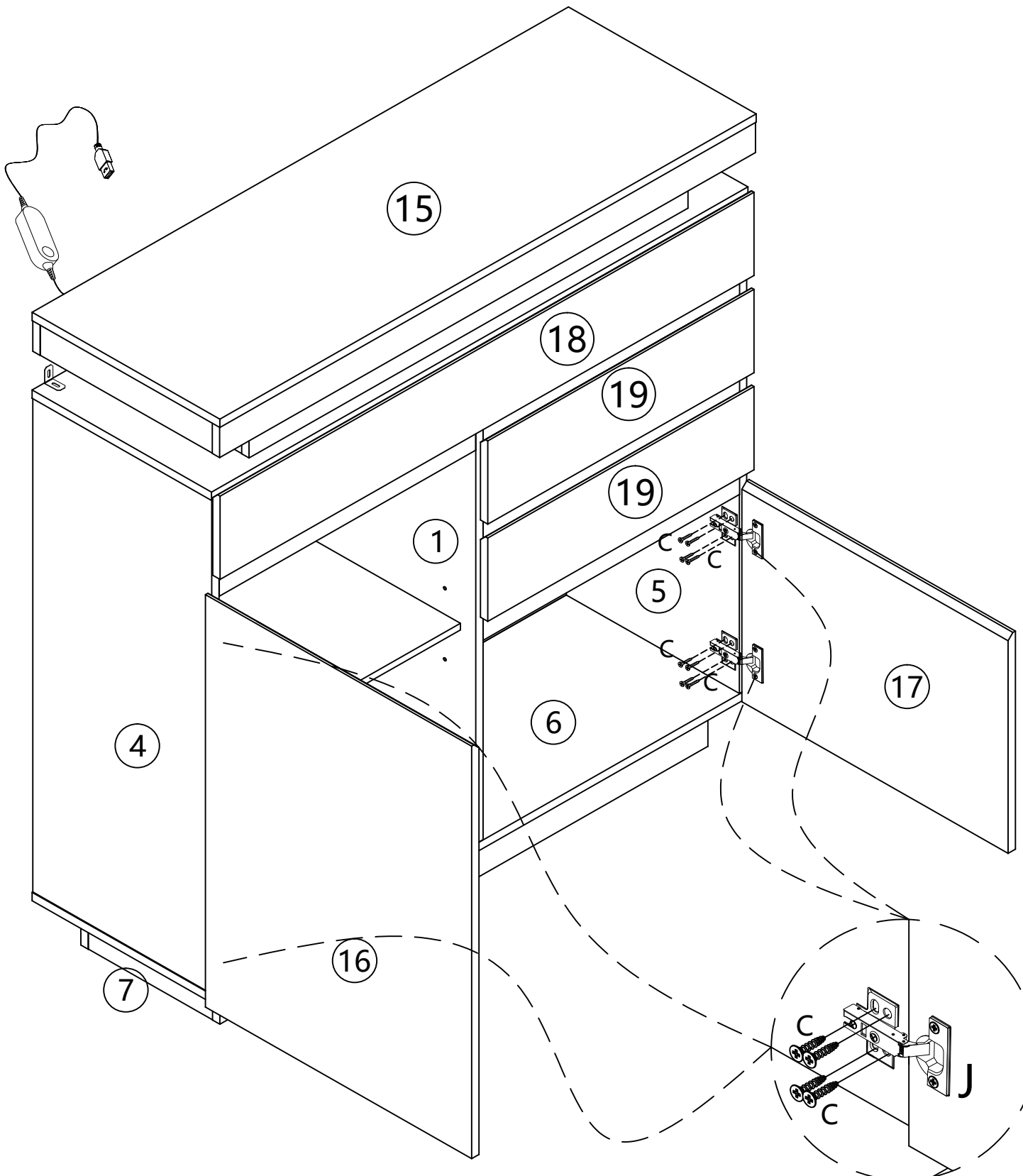

## If the door can't close, please adjust the hinges.

EN:To adjust the door verticallyloosen the screw as shownand move up and down as needed.

DE:Um die Tür vertikal einzustellen, lösen Sie die Schraube wie gezeigt und bewegen Sie sie nach Bedarf nach oben und unten.

FR:Pour régler la porte verticalement, desserrez la vis comme indiqué et déplacez-la de haut en bas selon vos besoins.

ES:Para ajustar la puerta verticalmente, afloje el tornillo como se muestra y muévalo hacia arriba y hacia abajo según sea necesario.

IT:Per regolare la porta verticalmente, allentare la vite come mostrato in figura e muoverla verso l'alto e verso il basso secondo necessità.

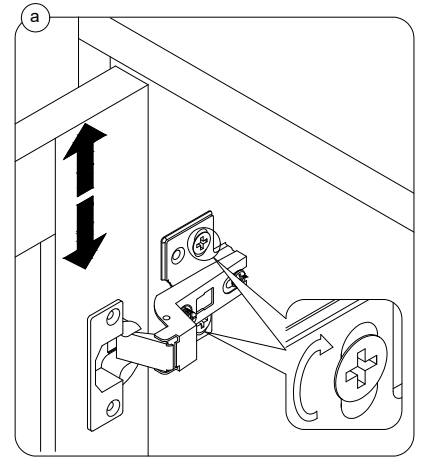

EN:To adjust the gap from the door to the main frame turn thescrew clockwise or anti-clockwise as needed.

DE:Um den Abstand zwischen der Tür und dem Hauptrahmen anzupassen, drehen Sie die Schraube je nach Bedarf im oder gegen den Uhrzeigersinn.

FR:Pour régler l'espace entre la porte et le cadre principal, tournez la vis dans le sens des aiguilles d'une montre ou dans le sens inverse des aiguilles d'une montre selon vos besoins.

ES:Para ajustar el espacio entre la puerta y el marco principal, gire el tornillo en el sentido de las agujas del reloj o en el sentido contrario a las agujas del reloj según sea necesario.

IT:Per regolare la distanza tra la porta e il telaio principale, ruotare la vite in senso orario o antiorario, a seconda delle necessità.

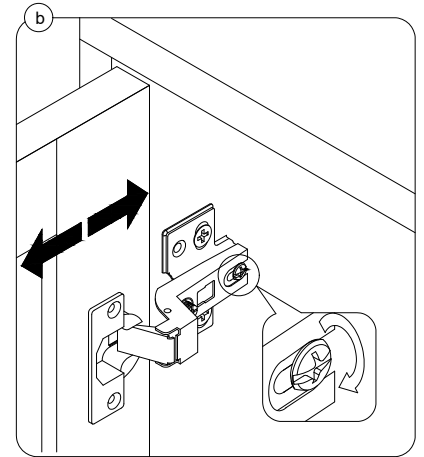

EN:To adjust the door laterally adjust the screw as shown byturning clockwise or anti-clockwise.

DE:Um die Tür seitlich auszurichten, verstellen Sie die Schraube wie gezeigt durch Drehen im oder gegen den Uhrzeigersinn.

FR:Pour régler la porte latéralement, ajustez la vis comme indiqué en tournant dans le sens des aiguilles d'une montre ou dans le sens inverse des aiguilles d'une montre.

ES:Para ajustar la puerta lateralmente, ajuste el tornillo como se muestra girándolo en el sentido de las agujas del reloj o en el sentido contrario a las agujas del reloj.

IT:Per regolare lateralmente la porta, regolare la vite come mostrato, ruotandola in senso orario o antiorario.

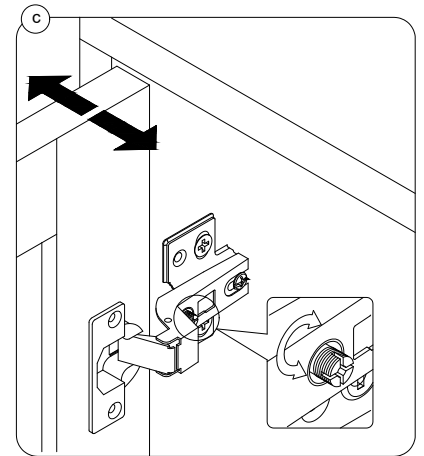

EN:Please fix other screws

DE:Bitte andere Schrauben anziehen

FR:Veuillez fixer les autres vis

ES:Por favor, arregle los otros tornillos.

IT:Per favore, fissa le altre viti

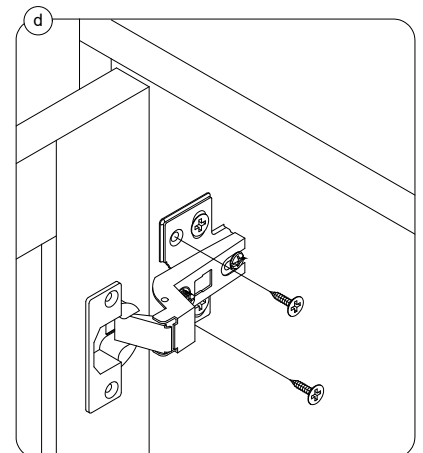

28



Cx18

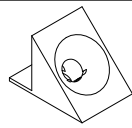

Kx18

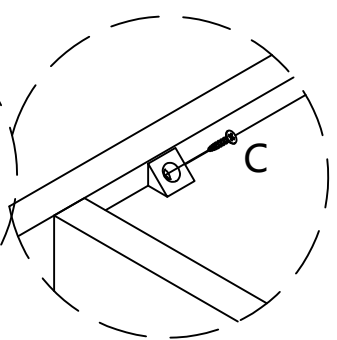
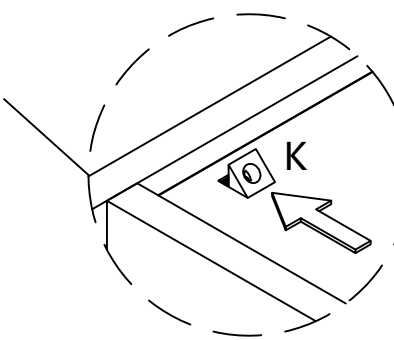
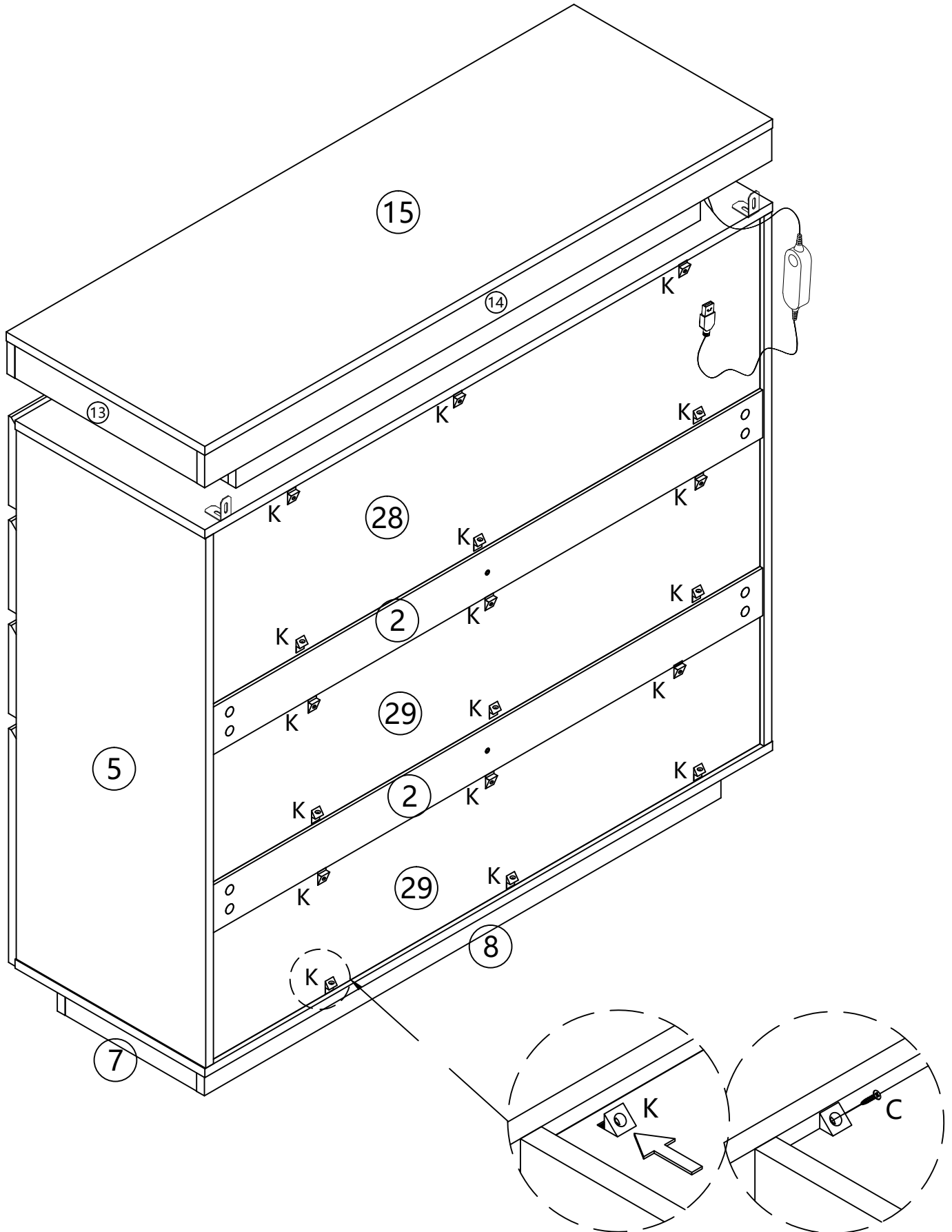

# 29

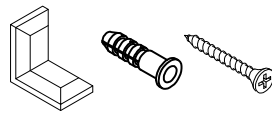

M×2

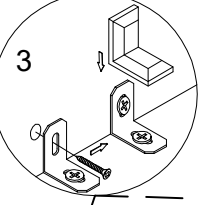
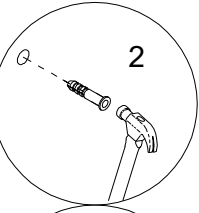
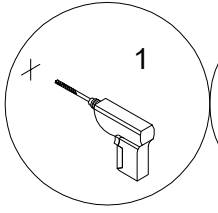

EN:Please decide whether to add anti tipping accessories based on personal needs  
DE:Bitte entscheiden sie in bezug auf ihre bedürfnisse, ob sie bauausrüstung hinzufügen sollen  
FR:S' il vous plaît décider d' ajouter des accessoires anti-basculement en fonction des besoins personnels  
IT:Decidere se aggiungere accessori anti-ribaltamento in base alle esigenze personali ES:Por favor, decida si desea añadir accesorios antipropinas en función de sus necesidades personales

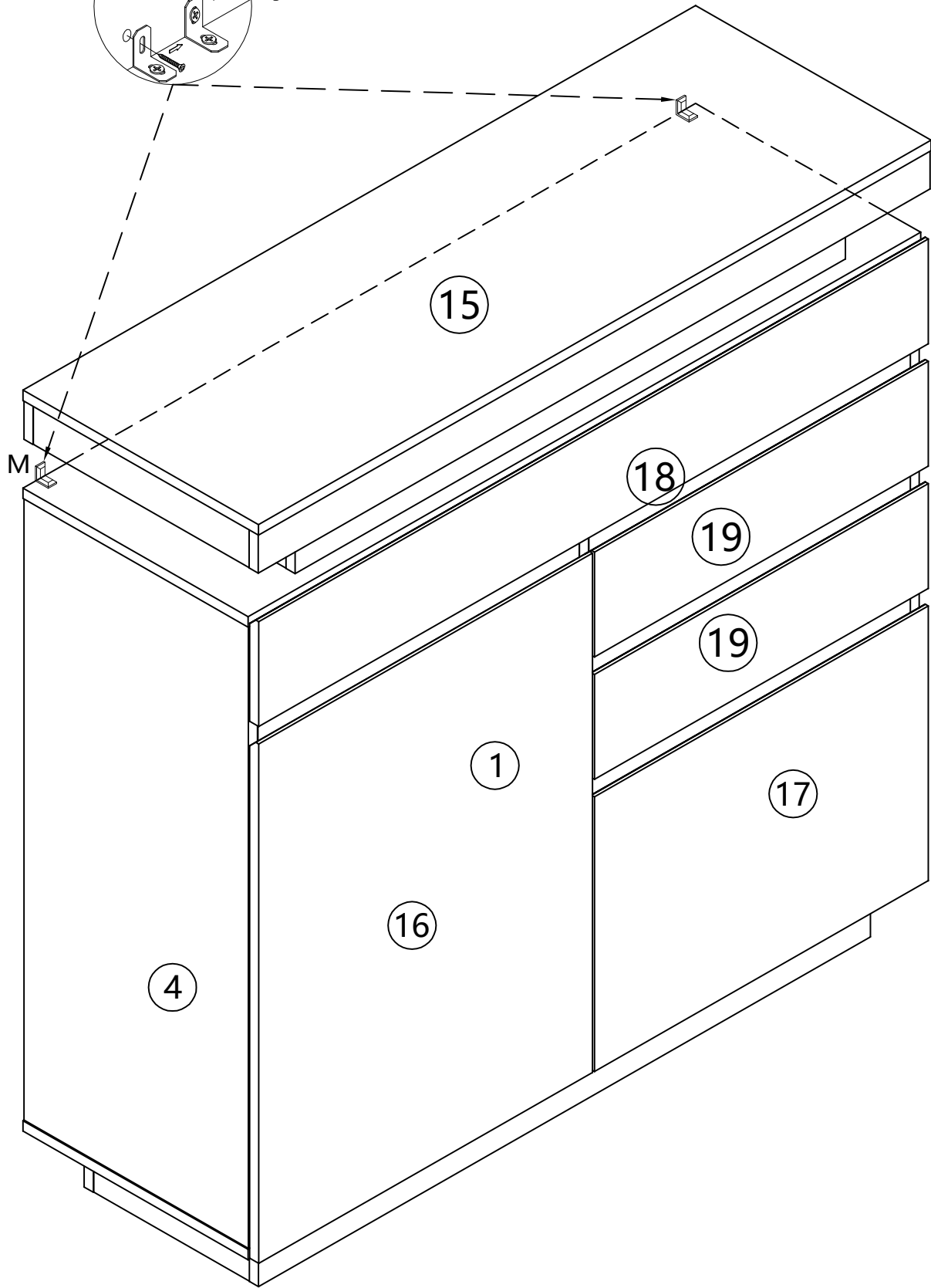

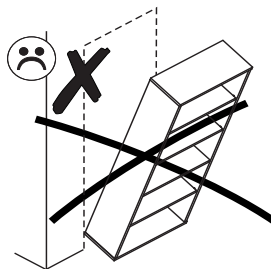
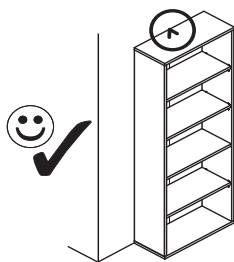

PL.

UWAGA! Mebel należy trwale zamocować do ściany, aby uniknąć ryzyka związanego z przewróceniem się mebla. W paczce znajdują się elementy mocujące odpowiednie wyłącznie do ścian betonowych lub z pełnej cegły.

Jeśli Twoja ściana wykonana jest z innego materiału lub nie masz pewności co do budowy tej ściany, skonsultuj się w kwestii montażu ze specjalistą.

D.

ACHTUNG! Um alle mit dem Umkippen des Möbels verbundenen Risiken auszuschließen, muss das Möbel fest an der Wand verankert werden.

Die im Paket enthaltenen Beschläge für die Wandbefestigung sind ausschließlich für Wände aus Beton oder Vollziegeln geeignet. Sollten die heimischen Wände aus anderem Baumaterial bestehen oder sollte es Zweifel in Hinsicht auf dieses Baumaterial geben, bitte eine Fachkraft zu Rate ziehen.

FR.

ATTENTION! Ce meuble doit être fixé en permanence au mur pour éviter les risques de chute. L'ensemble comprend des moyens de fixation adaptés uniquement aux murs de béton ou de brique. Si votre mur est fait d'un matériau différent ou si vous êtes incertain quant à la construction du mur, consultez un spécialiste.

I.

ATTENZIONE! Il mobile deve essere permanentemente fissato alla parete per evitare i rischi derivanti da un ribaltamento del mobile. La confezione contiene solo elementi di fissaggio adatti per pareti in calcestruzzo o in laterizio pieno. Se la vostra parete è realizzata in materiale diverso o avete dubbi sulla costruzione della parete, consultare uno specialista per un montaggio corretto.

RU.

ПРИМЕЧАНИЕ! Эту мебель необходимо всегда прикреплять к стене, чтобы избежать рисков, связанных с переворотом мебели. В пакете находятся крепительные элементы, которые подходят исключительно к бетонным стенам или из целого кирпича. Если стена изготовлена из другого материала или Вы не уверены относительно строения стены, проконсультируйтесь относительно монтажа со специалистом.

EN.

WARNING! To prevent this furniture from tripping over, fix it to the wall permanently. The package includes fastening elements only suitable for concrete or full-brick walls. If your wall is made of a different material or you are unsure as to the construction of the wall, please consult a specialist regarding installation.

SK.

POZOR! Nábytok musí byť trvalo pripevnený k stene tak, aby sa zamedzilo riziku prevrátenia. V balíku sa nachádzajú upevňovacie komponenty výlučne pre betónové steny alebo steny z plnej tehly. Ak je Vaša stena z iného materiálu alebo ak si nie ste istí, z čoho je stena vyhotovená, vyžiadajte si odbornú pomoc.

CZ.

POZOR! Nábytek je nutné pevně připevnit ke zdi, abychom se vyhnuli riziku spojenému s jeho převrnutím. V balíčku se nacházejí připevňující prvky vhodné výhradně do betonových zdí nebo zdí z plných cihel. Pokud jsou Vaše zdi zhotoveny z jiného materiálu nebo si nejste jejich konstrukcí jisti, konzultujte otázku montáže se specialistou.

RO.

ATENȚIE! Mobila trebuie ancorată permanent în perete pentru a evita riscul de răsturnare a mobilei. Pachetul conține elementele de fixare potrivite numai pentru pereții din beton sau din cărămidă solidă. Dacă peretele Dvs. este realizat dintr-un alt material sau nu sunteți sigur care este structura peretelui, consultați un specialist în privința montajului.

NL.

OPMERKING! De meubelen moeten permanent aan de muur worden bevestigd om te voorkomen dat de meubelen kantelen. Het pakket bevat bevestigingselementen die alleen geschikt zijn voor betonnen of massieve bakstenen muren. Als uw muur van een ander materiaal is gemaakt of als u niet zeker bent over de constructie van deze muur, raadpleeg dan een specialist voor de installatie.

TR.

DİKKAT! Devrilmeye riskini önlemek için mobilya duvara sabitlenmelidir. Pakette, sadece beton veya tam tuğla duvarlara uygun sabitleme elemanları bulunmaktadır. Eğer duvarınız başka bir malzemeyle yapıldıysa veya duvar yapısından emin değilseniz, montaj konusunda bir uzmana danışınız.

AR.

## ملاحظة!

يجب تثبيت الأثاث بإحكام إلى الحائط أو الجدار لتجنب خطر انقلابه. تحتوي العبوة على مسامير التثبيت التي تناسب الجدران الخرسانية أو الطوب. إذا كان جدارك مصنوعاً من مادة مختلفة أو لم تكن متأكدًا من مادة بنائه اسأل المتخصص عن كيفية التثبيت.

E.

¡ATENCIÓN! El mueble debe ser fijado permanentemente a la pared para evitar el riesgo relacionado con el vuelco del mueble. En el paquete hay elementos de fijación adecuados solo para paredes de hormigón o de ladrillo entero. Si su pared está hecha de otro material o no está seguro sobre la construcción de esta pared, consulte el montaje con un especialista.

CN.

注意！本家具需要固定在墙上以免倒塌。本包所包含的固定部件仅适用于混凝土墙及整砖墙。欲使用在其他墙体或不确定墙体时，请向专家询问安装方式。

HR.

NAPOMENA! Namještaj mora biti trajno pričvršćen za zid, kako bi se izbjegao rizik od njegova prevrtanja. U paketu se nalaze elementi za pričvršćivanje prikladni isključivo za betonske zidove ili punu ciglu. Ako je Vaš zid izrađen od drugog materijala ili niste sigurni od čega je napravljen Vaš zid, konzultirajte se sa stručnjakom u vezi sa montažom.

SLO.

POZOR! Pohištvo trajno pritrdite na steno, da preprečite tveganje, da se prevrne. V paketu so pritriljni elementi, ki so ustrezni izključno za betonske stene in za stene iz polne opeke. Če je vaša stena izdelana iz drugih materialov ali niste gotovi glede konstrukcije stene, se o montaži posvetujte s strokovnjakom.

HU.

FIGYELEM! Rögzítse a bútorokat a falhoz, hogy elkerülje a bútor felborulásának kockázatát. A készletben kizárólag beton- vagy téglafalhoz használható kötőelemek találhatók. Ha a fal más anyagból készült, vagy ha nem tudja, milyen falak találhatók otthonában, forduljon szakemberhez.

# Attestation of Compliance

**Declaration No.:** TMC210319128-E

**Name and address of Applicant:** **Shenzhen CWG Technology Co., Ltd**  
5 / F, No.264 Baoshi East Road, Shiyan street, Bao'an District, Shenzhen,China  
518108

**Name and address of Manufacturer:** **Shenzhen CWG Technology Co., Ltd**  
5 / F, No.264 Baoshi East Road, Shiyan street, Bao'an District, Shenzhen,China  
518108

**Product name:** **LED Strip**

**Rated:** DC12V  
CWG-5050RGB-60D-12V, CWG-5050RGB-30D-12V , CWG-5050RGB-18D-12V,  
CWG-5050RGB-60D-24V, CWG-5050RGB-60D-5V, CWG-5050RGB-30D-5V,  
CWG-5050RGB-18D-5V, CWG-5050-60D-12V, CWG-5050-30D-12V,  
CWG-5050-60D-24V, CWG-HC5050RGB-60D-12V,  
CWG-HC5050RGB-30D-12V, CWG-HC5050RGB-60D-24V,  
**Product model(s):** CWG-HC5050-60D-12V, CWG-HC5050-30D-12V, CWG-HC5050-60D-24V,  
CWG-HC5050RGB-30D-5V, CWG-HC5050RGB-60D-5V,  
CWG-HC5050RGB-144D-5V, CWG-2835-60D-12V, CWG-2835-120D-12V,  
CWG-2835-60D-24V, CWG-2835-120D-24V, CWG-2835-60D-5V,  
CWG-2835-120D-5V

**Product trademark:** 创唯光

This Attestation of Compliance confirms that the product meets the requirements of the following standard.

BS EN IEC 55015:2019+A11:2020

IEC 61547:2020

*The Attestation of Compliance has been carried out in accordance with individual rules and conditions agreed with the applicant. Evaluation has been carried out in accordance with:*

**Test report(s) No.:** TMC210319128-E

**Test conducted by:** TMC Testing Services (Shenzhen) Co., Ltd.

**Declaration issue date:** March 26, 2021

**Notes:**

*This Attestation of Compliance is issued according to the Great Britain legislation Electromagnetic Compatibility Regulations 2016 It confirms that the listed products complies with all essential requirements of the Regulations and applies only to the sample and its technical documentation to TMC Testing Services (Shenzhen) Co., Ltd. for testing.*

*After preparation of the necessary technical documentation (which must be kept for up to 10 years after the product is placed on the GB market) as well as the UK Declaration of Conformity, the required UKCA marking can be affixed on the product. Other relevant Regulations have to be observed.*

**TMC Testing Services (Shenzhen) Co., Ltd.**

t:86-755-86642861 cert@tmc-lab.com www.tmc-lab.com

1st Floor, Block A1, Zone A, Xinshidai Gongrong Industrial Park, No. 2, Shihuan Road, Shiyan Street, Baoan District, Shenzhen, China



**UK  
CA**