

Table

Assembly Instruction – Please keep properly for future reference.

If you find any missing boxes, damaged parts, or accessory shortages, please contact the customer service team of your purchasing channel immediately. We will resolve the issue as quickly as possible.

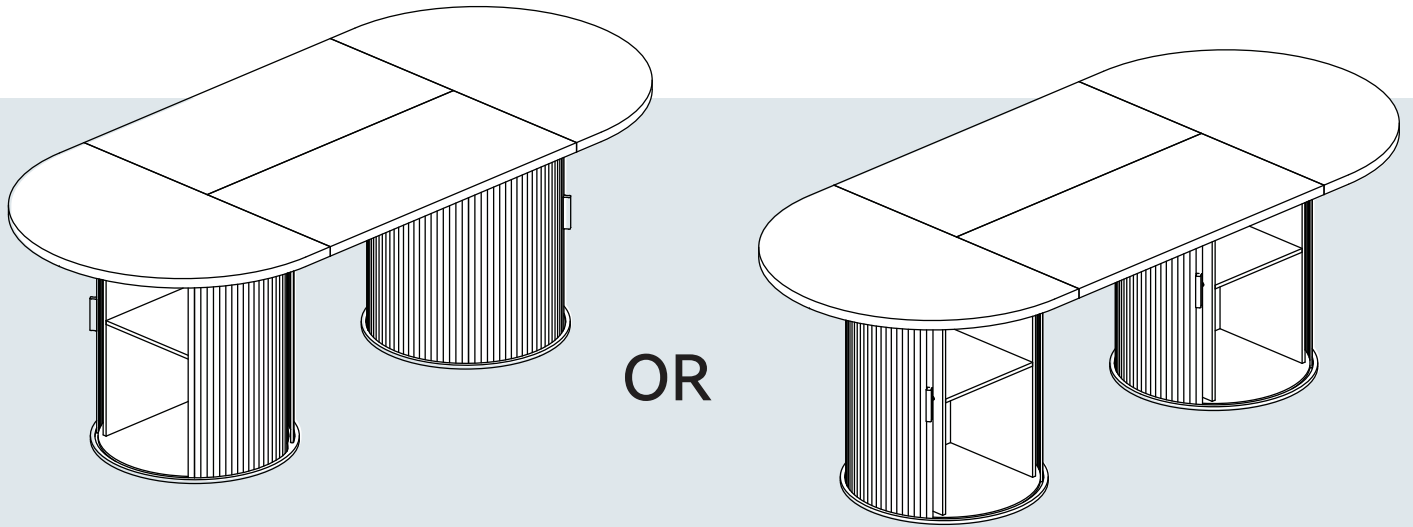

Dimensions

Width-86.6 inch
Depth-35.8 inch
Height-64.9 inch

EN

THE FOLLOWING INFORMATION:

- Order number
- Purchase platform
- Purchase date
- Detailed description of the issue along with photos (if applicable)

Important – Please read these instructions carefully before starting the installation.



Safety and Care Advice

Important – Please read these instructions fully before starting assembly

- Check you have all the components and tools listed on the following pages.
- Remove all fittings from the plastic bags and separate them into their groups.
- Keep children and animals away from the work area, small parts could choke if swallowed.
- Make sure you have enough space to layout the parts before starting.

- During assembly do not stand or put weight on the product, this could cause damage.
- Assemble the item as close to its final position (in the same room) as possible.
- Assemble on a soft level surface to avoid damaging the unit or your floor.
- Parts of the assembly will be easier with 2 people.



- To reduce the likelihood of damaging your product please ensure that your power drill is set on a low torque setting.

Care and maintenance

- Only clean using a damp cloth and mild detergent, do not use bleach or abrasive cleaners.
- From time to time check that there are no loose screws on this unit.
- This product should not be discarded with household waste. Take to your local authority waste disposal centre.

Handy Hints

- Assemble all parts and bolts loosely during assembly, only once the product is complete should you fully tighten the bolts
- Regularly check and ensure that all bolts and fittings are tightened properly.

WARNING In order to help prevent overturning – please follow these instructions

To help prevent product toppling over please follow the below steps:-

Use the anti tip strap or wall fixing method provided (if applicable)
Do not allow children to climb or hang on the furniture
Do not open more than one drawer at a time
Do not place heavy items in the top drawers
Do not place heavy items on top of the furniture, unless the furniture has been designed for this purpose

Please note that only the anti tip strap is provided.
You will need to provide wall plugs and screws applicable for your wall type

CUSTOMER SERVICE GUIDE

Thank you for choosing our product! We are committed to providing you with excellent service. If you find any missing parts, damaged packaging, or product damage after receiving all packages, please follow the steps below to quickly contact our customer service team. We will do our best to resolve your issue.

1. Missing Parts

Verify Parts:

1. Refer to the “Parts List” in the manual to verify the name, specifications, and quantity of the missing parts.
2. Take a clear photo of the parts list and mark the missing parts with detailed information, e.g., “Missing 5 pieces of M6x30mm screws.”

Contact Us:

- A description of the missing parts and a photo of the parts list.
- Order details (order number, purchase platform, purchase date).

2. Product or Packaging Damage

If it affects normal use:

Steps:

1. Take clear photos or videos showing the damaged parts and the extent of the damage (multi-angle shots are recommended).
2. Email the photos/videos along with other details to us with the subject line "Product Damage Issue."

Resolution:

After verification, we will arrange for a replacement part, product exchange, or refund as quickly as possible.

If it does not affect normal use:

Steps:

1. Contact our customer service team
2. Provide a description of the damage and include relevant photos or videos.

Resolution:

We will provide repair guidance or an appropriate compensation plan based on the specific situation.

Helpful Tips

To process your issue efficiently, please prepare the following information:









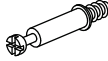

- Order details (order number, purchase platform, purchase date).
- Clear photos or videos.
- We are committed to providing quick and professional solutions, no matter the size of the issue, to ensure your satisfaction.

Thank you for your trust and support! We hope you enjoy using our product!

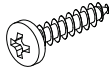
Componets - Fittings

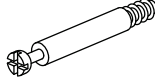
Please check you have all the fittings listed below

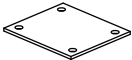
Note: The quantities below are the correct amount to complete the assembly. In some cases more fittings may be supplied are required.

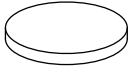
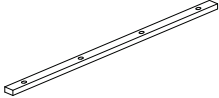
A  6*30mm Wooden Dowel x 40	B  6*35mm Cam Bolt x 12	C  Cam Lock x 24
D  8*40mm Wooden Dowel x 15	E  4*14mm Screw x 4	F  4*20mm Screw x 4
G  5*40mm Screw x 28	H  6*20mm Bolt x 32	I  6.5*60mm Cam Bolt x 12
J  x 12	K  x 1	L  x 2
M  x 1	N  x 8	O  x 4

Tools required

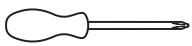

Phillips screwdriver
(medium & large)

Ruler - Use this ruler to help correctly identify the screws

mm

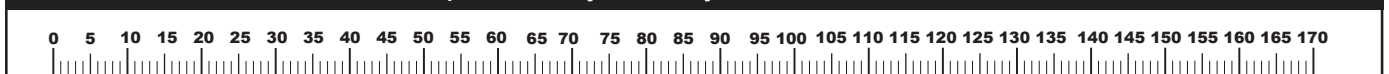

The screws length is measured from the head to the point (30mm screw shown).



inch

Using Camlocks

Step 1

Connect the male camlock as directed in the assembly instructions using a screwdriver.

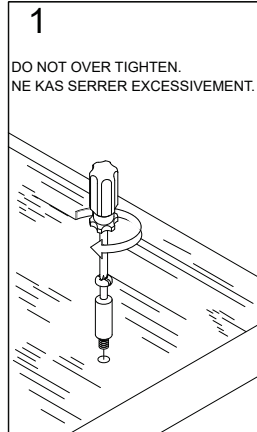

Step 2

Push the male camlock into the entry hole.

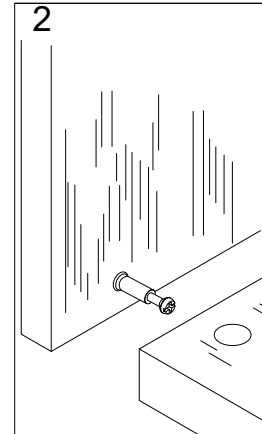

Step 3

Insert the female camlock as shown in the instructions.

Note: ensure that the arrow on the top of the camlock points towards the entry hole for the male camlock.

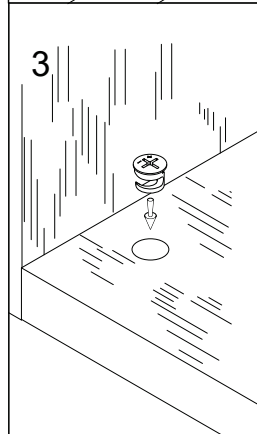

Step 4

Turn the female camlock clockwise with a screwdriver.

You should feel a click when the camlock is locked in place.

The joint is now secure.

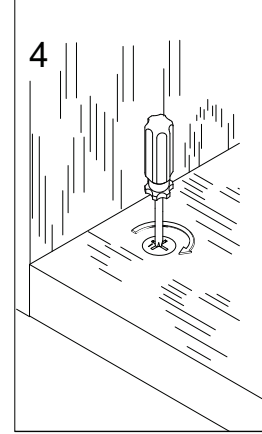

Componets - Panels

Please check you have all the panels listed below

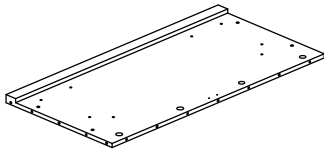

1 (1000*500*30mm x1)

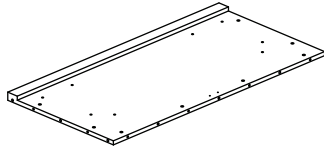

2 (1000*500*30mm x1)

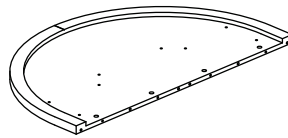

3 (1000*600*30mm x2)

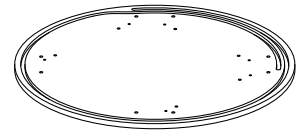

4 (600*600*12mm x2)

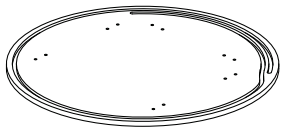

5 (600*600*12mm x2)

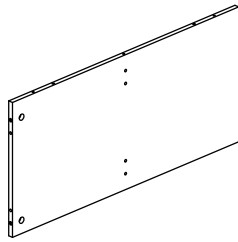

6 (720*335*12mm x2)

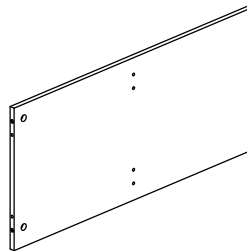

7 (720*335*12mm x2)

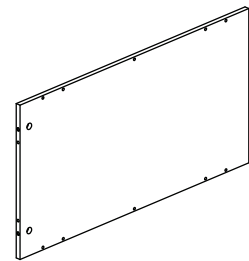

8 (720*380*12mm x2)

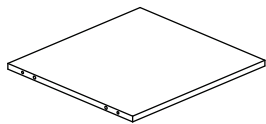

9 (355*335*12mm x2)

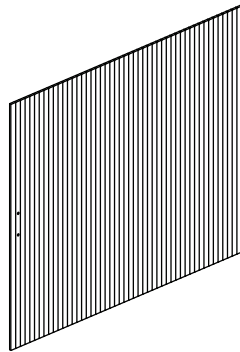

10 (885*731*6mm x2)

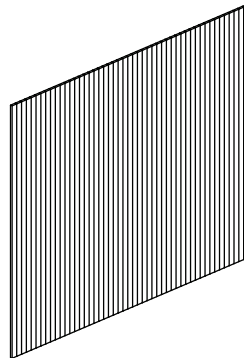

11 (885*731*6mm x2)

Assembly Instructions

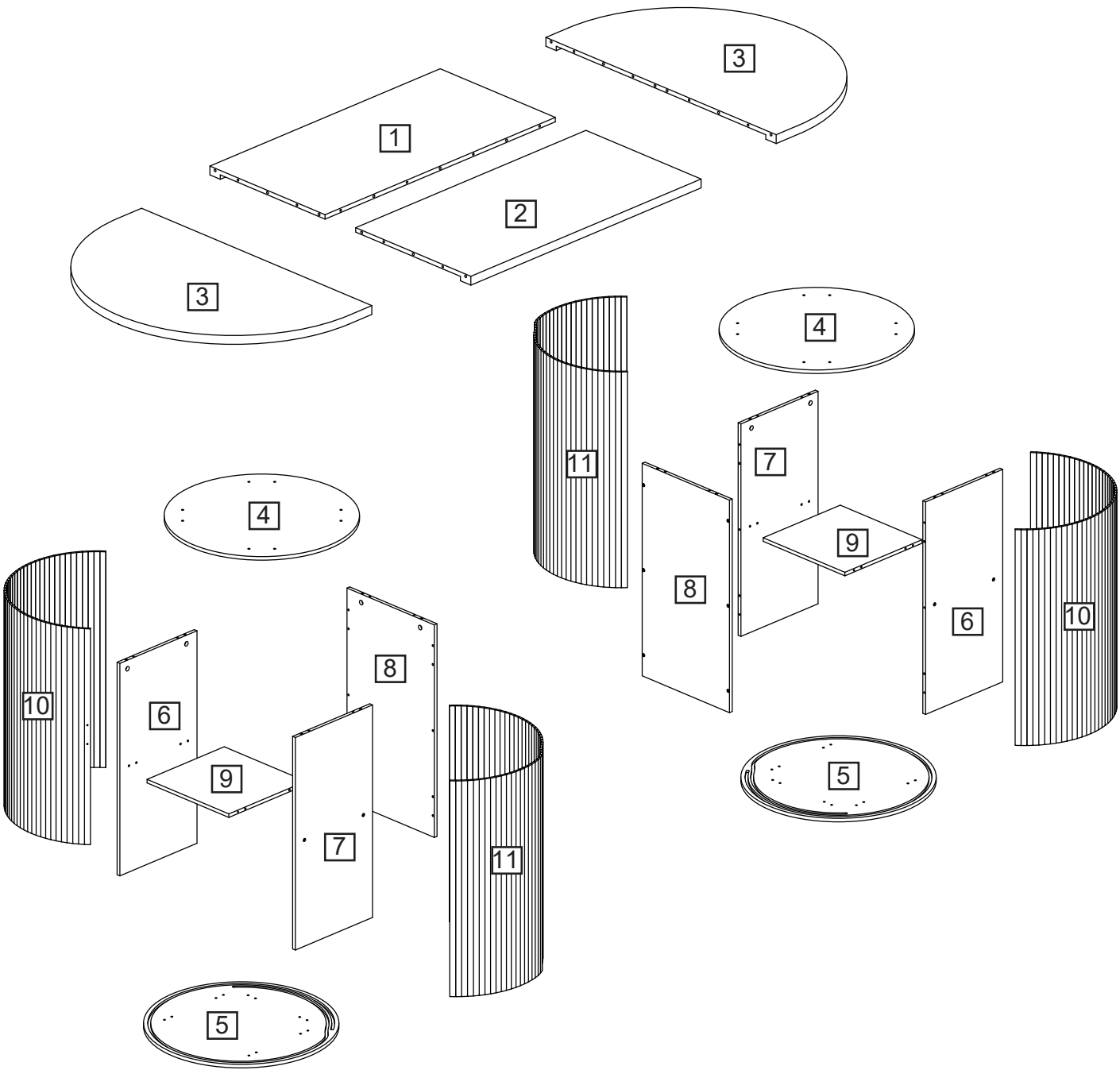

Assembly Instructions

Step 1

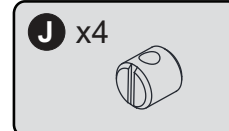
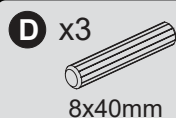

Attach the nut (J) and screw (I) to (Part 2), and insert the dowel (D) into (Part 2).

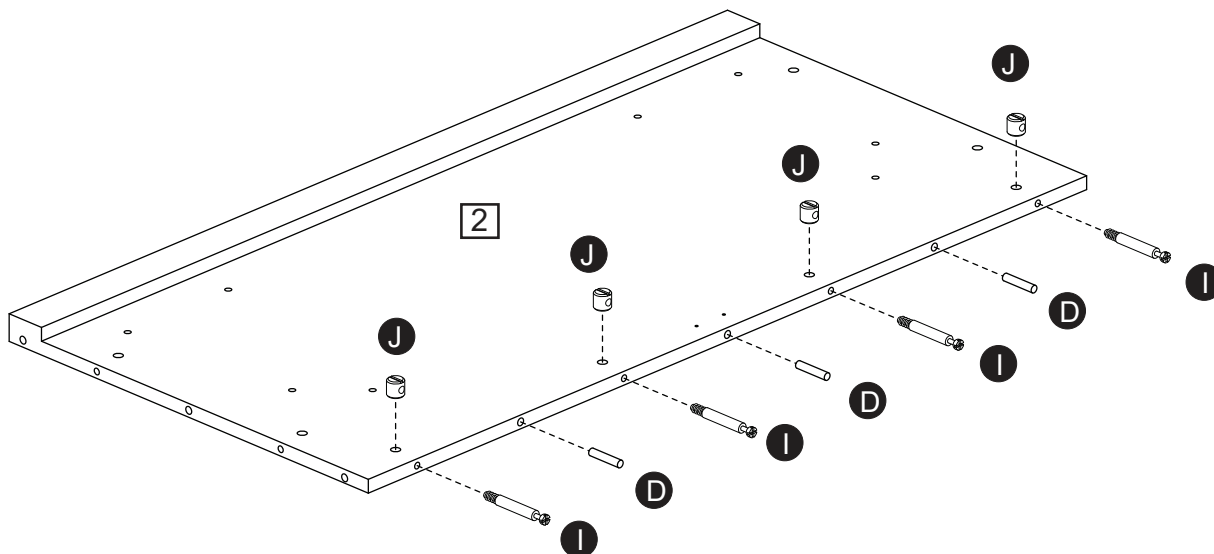

Step 2

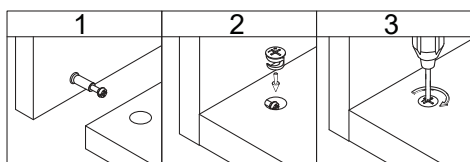
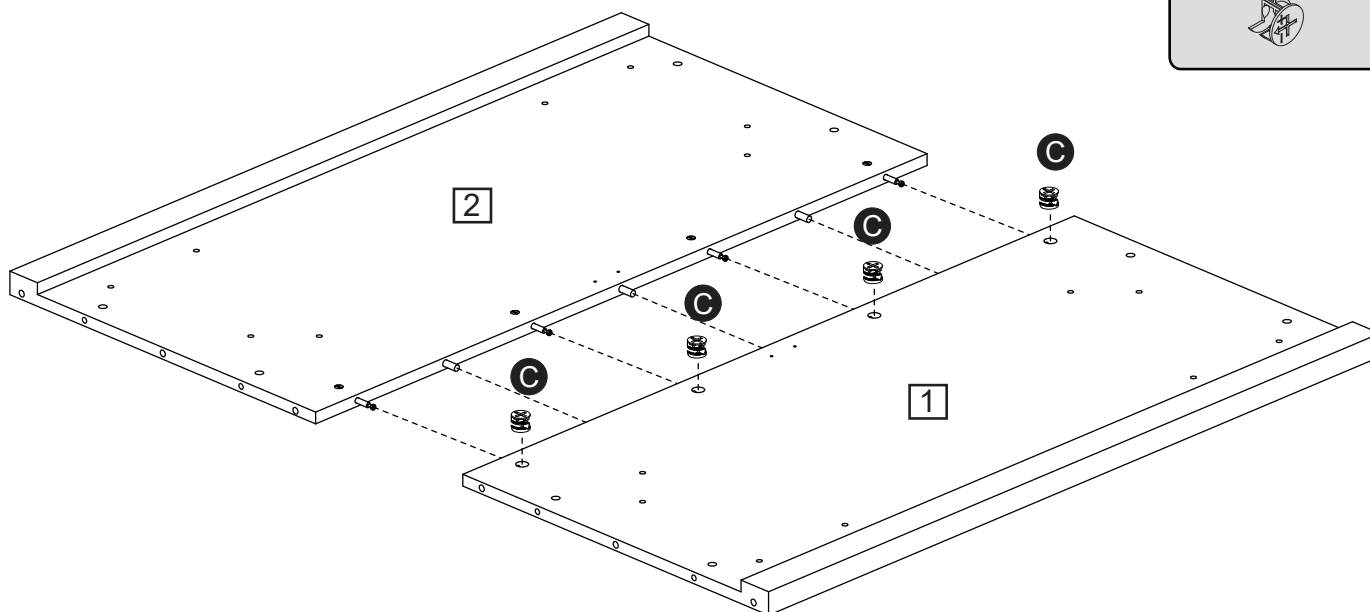

Align (Part 1) and (Part 2) together, place the eccentric wheel (C) in, and tighten it.

Assembly Instructions

Step 3

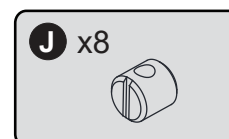
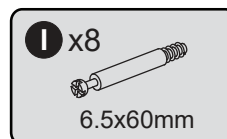
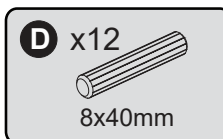

Attach the nut (J) and screw (I) to (Part 1) and (Part 2), and insert (D) into (Part 1) and (Part 2).

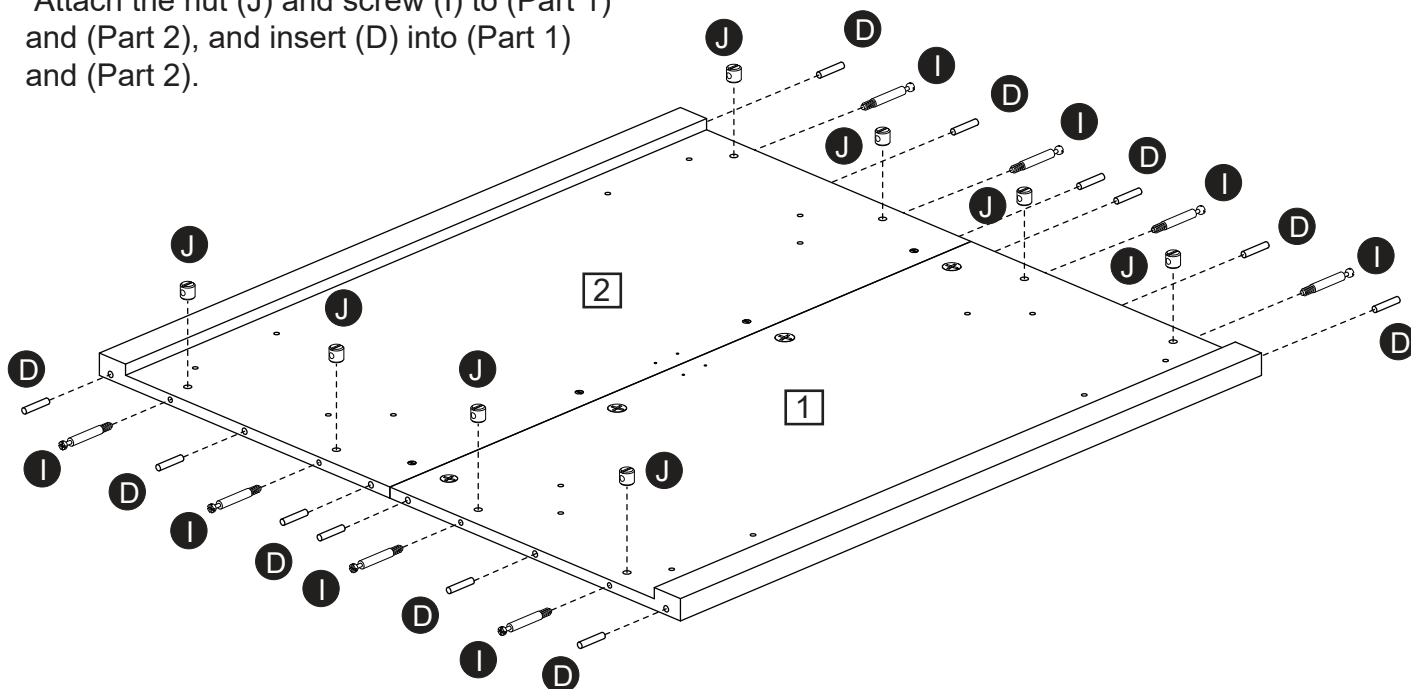

Step 4



Align (Part 3) with (Part 1) and (Part 2), place the eccentric wheel (C) in, and tighten it.

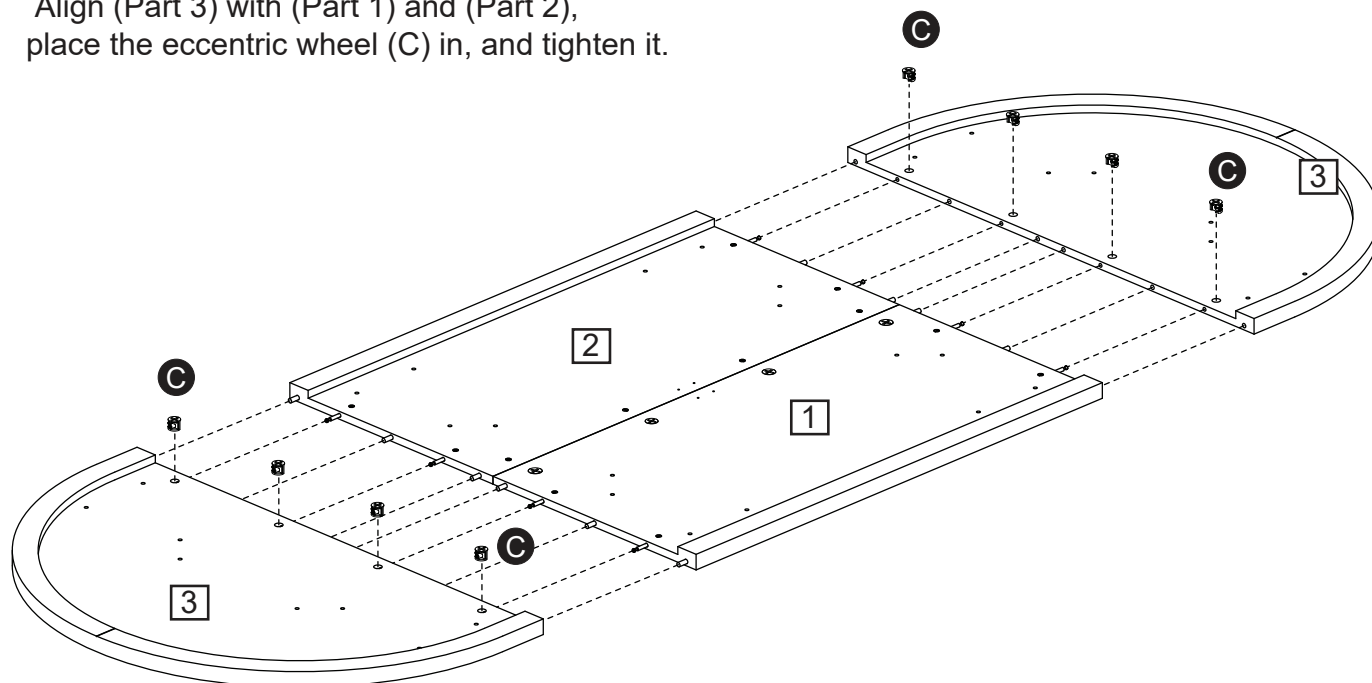

Assembly Instructions

Step 5

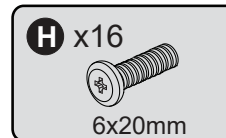
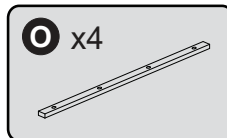
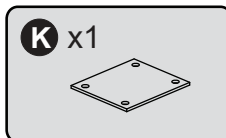
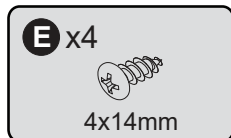

Use the bolt (H) to assemble the iron pipe (O) to the position shown in the diagram, and use the screw (E) to attach the iron plate (K) to (Part 1) and (Part 2).

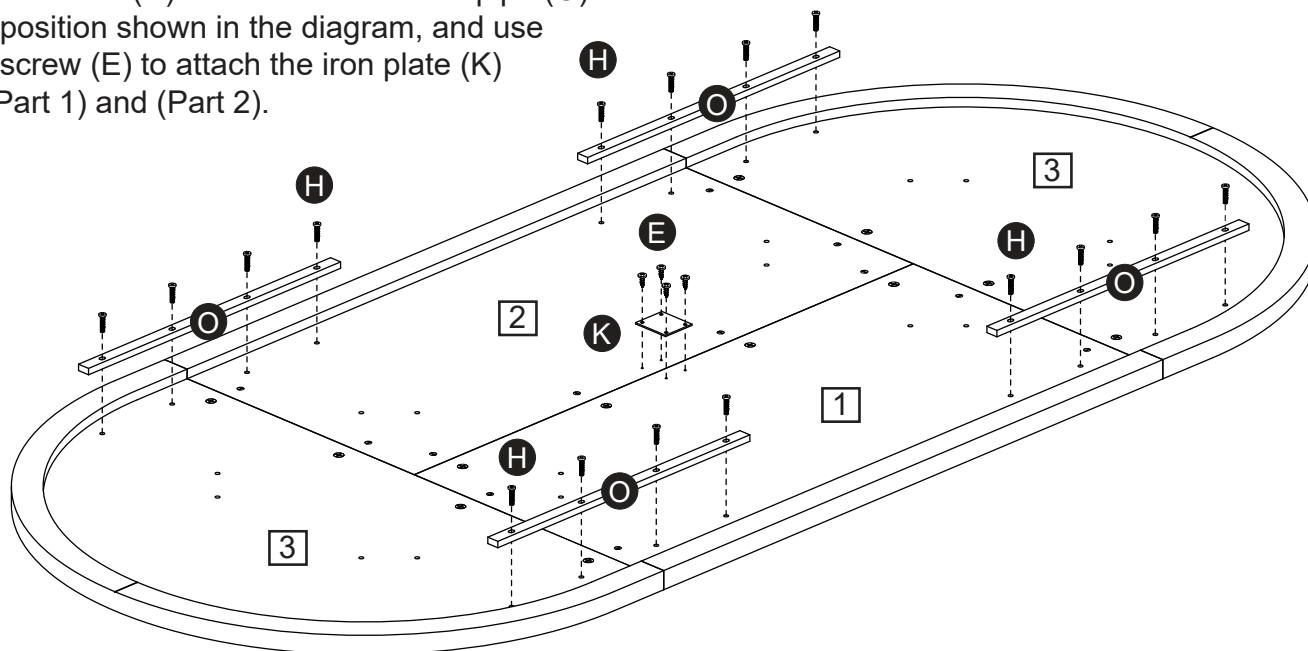

Step 6

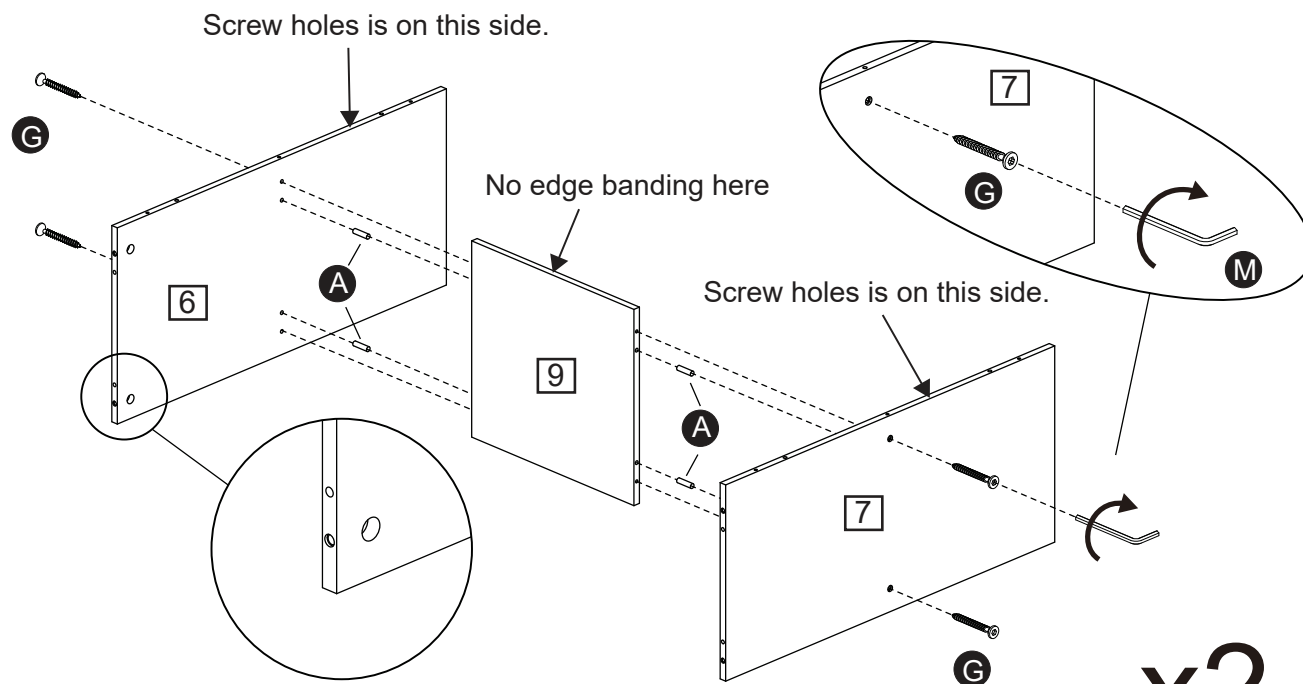
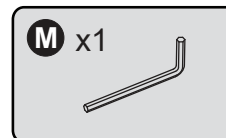
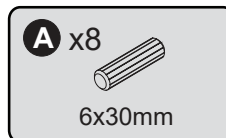

Use the screw (G) and dowel (A) to assemble (Part 6) and (Part 7) onto (Part 9).

Assembly Instructions

Step 7

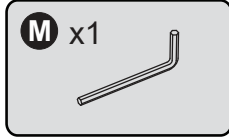
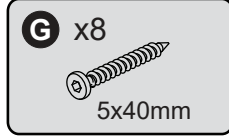
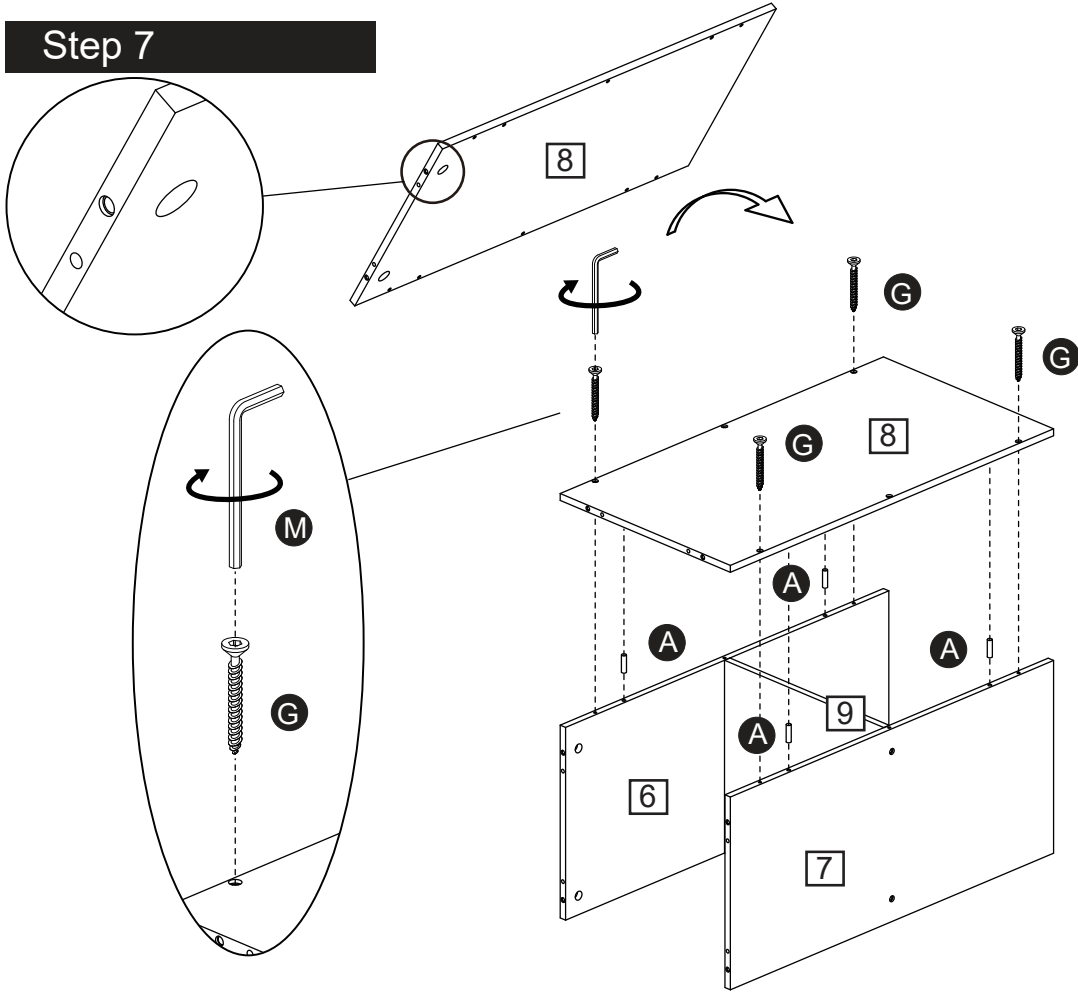

x2

Use the screw (G) and dowel (A) to assemble (Part 8) onto (Part 6), (Part 7), and (Part 9).

Step 8

CAM-LOCK
Tighten until shoulder is flush with panel. Do not overtighten or undertighten (see example below)

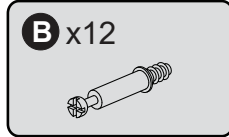
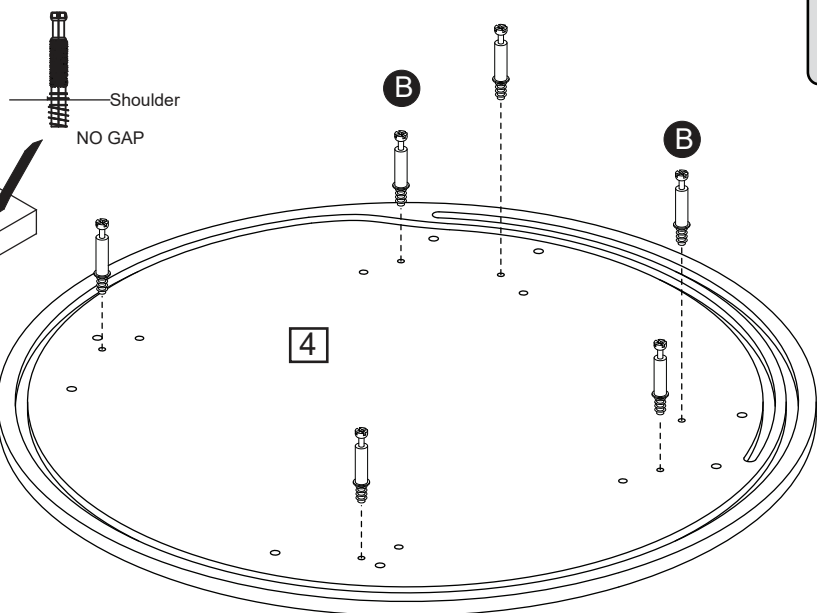
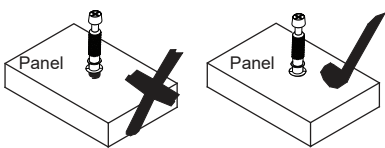

x2

Assemble the screw (B) onto (Part 4).

Assembly Instructions

Option 1 There are two types of opening directions for the table leg shelf:
For Option 1, please refer to Pages 12-18.
For Option 2, please refer to Pages 19-24.

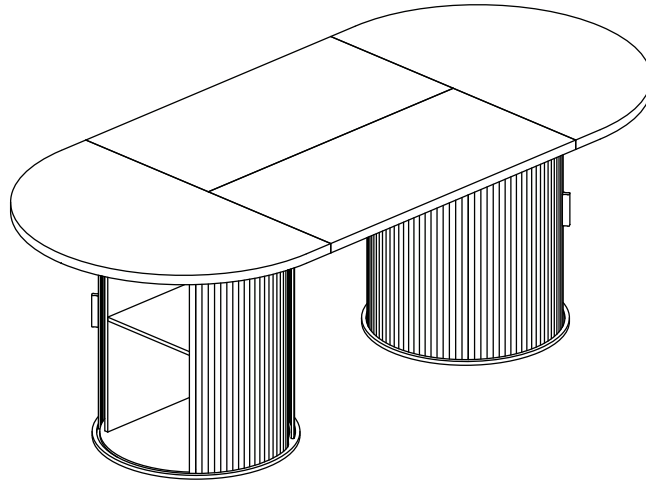

Step 9

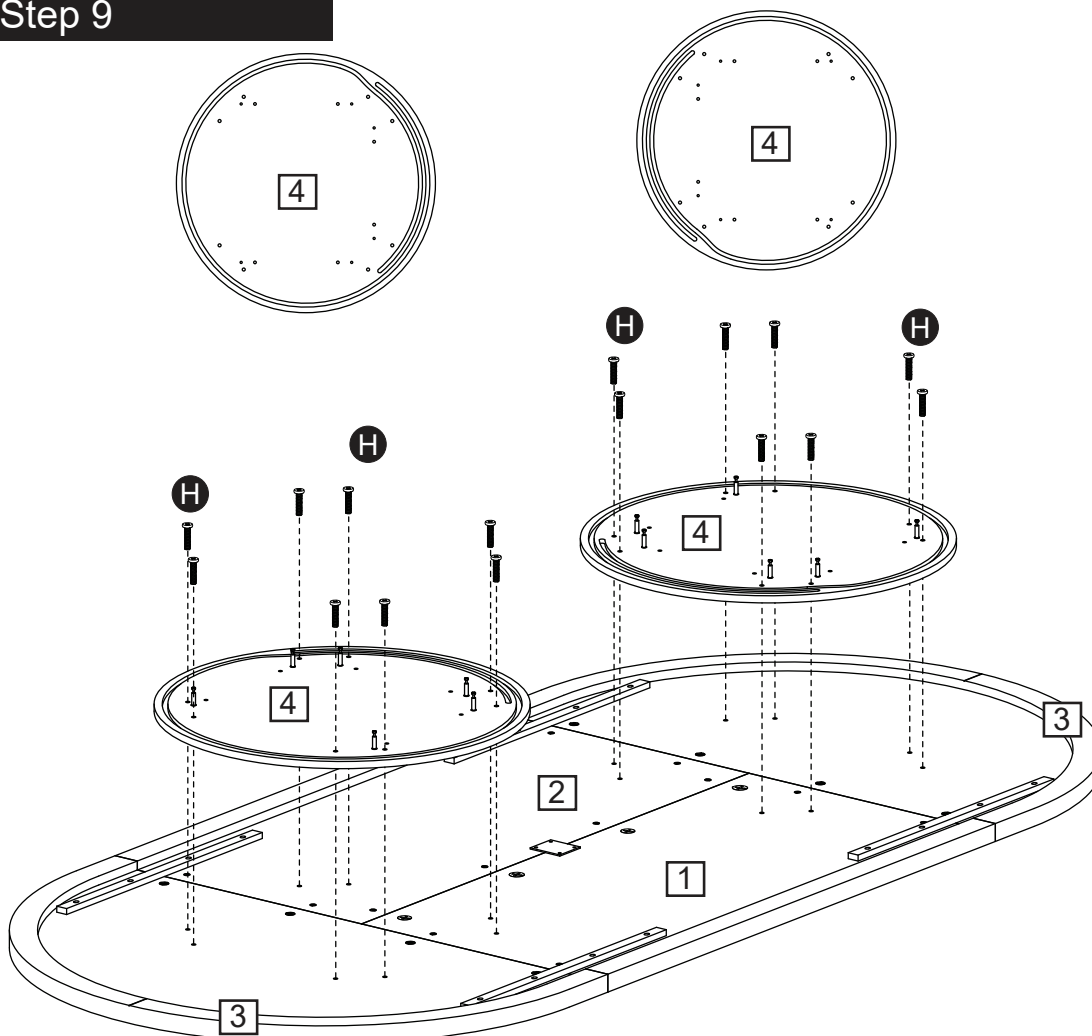
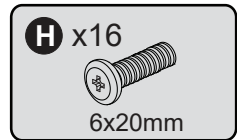

Use the bolt (H) to assemble (Part 4) onto (Part 1), (Part 2), and (Part 3).

Assembly Instructions

Step 10

Use the eccentric wheel (C) and dowel (A) to assemble (Part 6), (Part 7), and (Part 8) onto (Part 4).

A x12



6x30mm

C x12

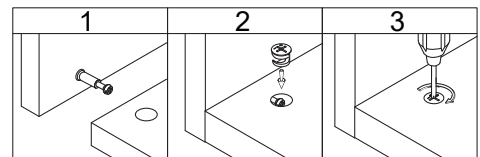
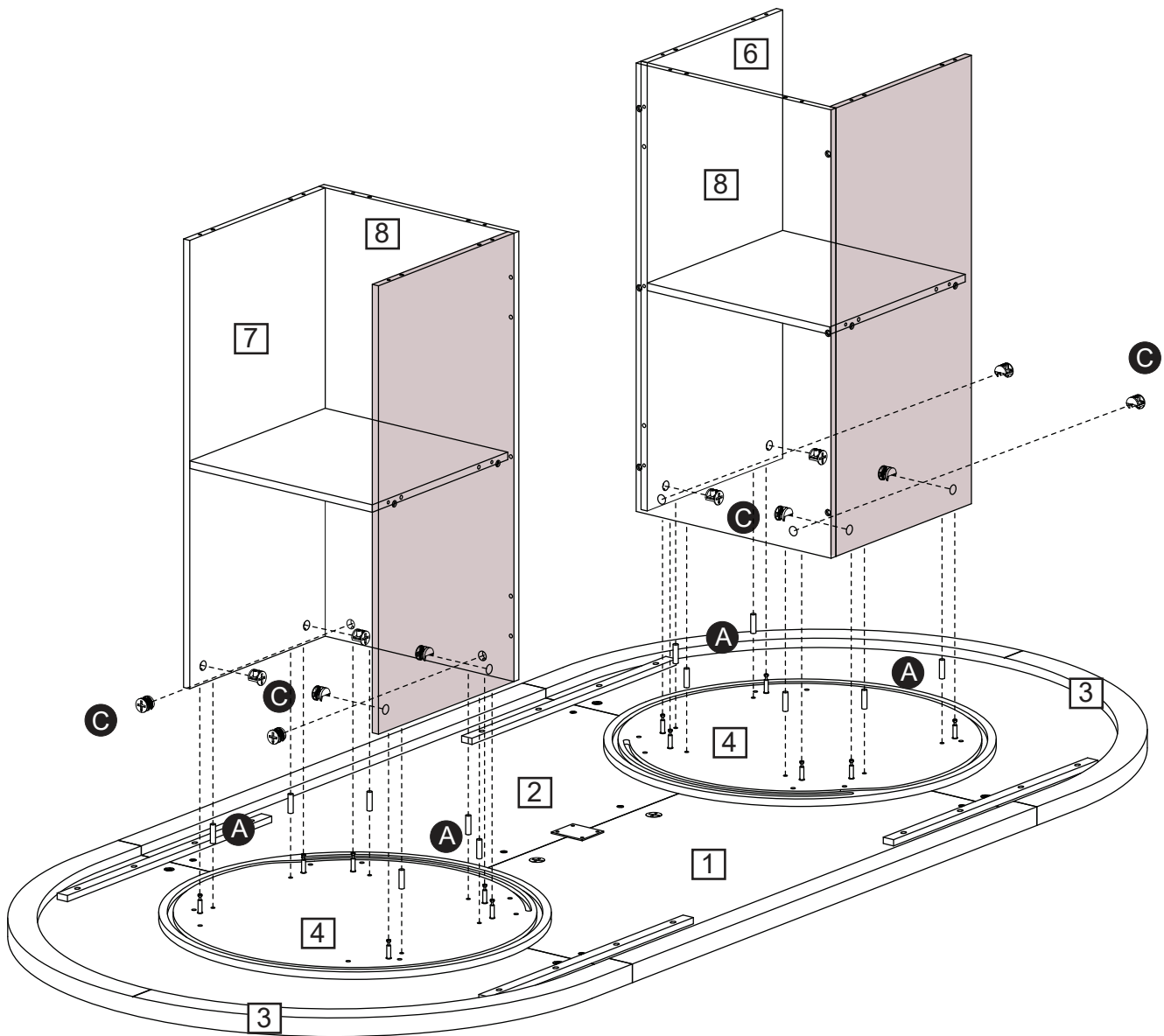

Assembly Instructions

Step 11

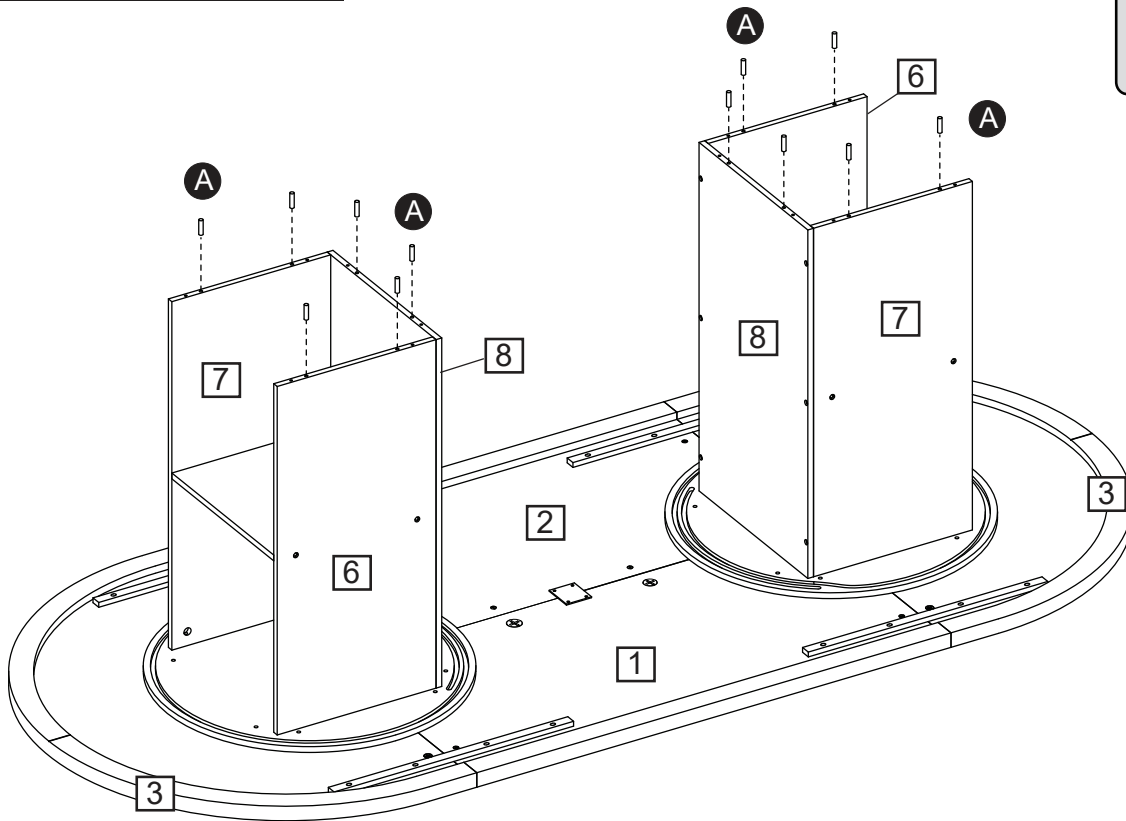
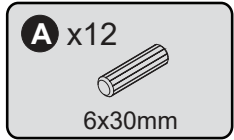

Insert the dowel (A) into (Part 6), (Part 7), and (Part 8).

Step 12

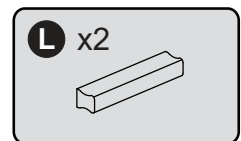
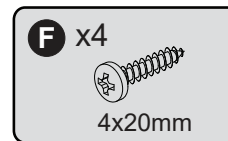

Use the screw (F) to assemble the handle (L) onto (Part 10).

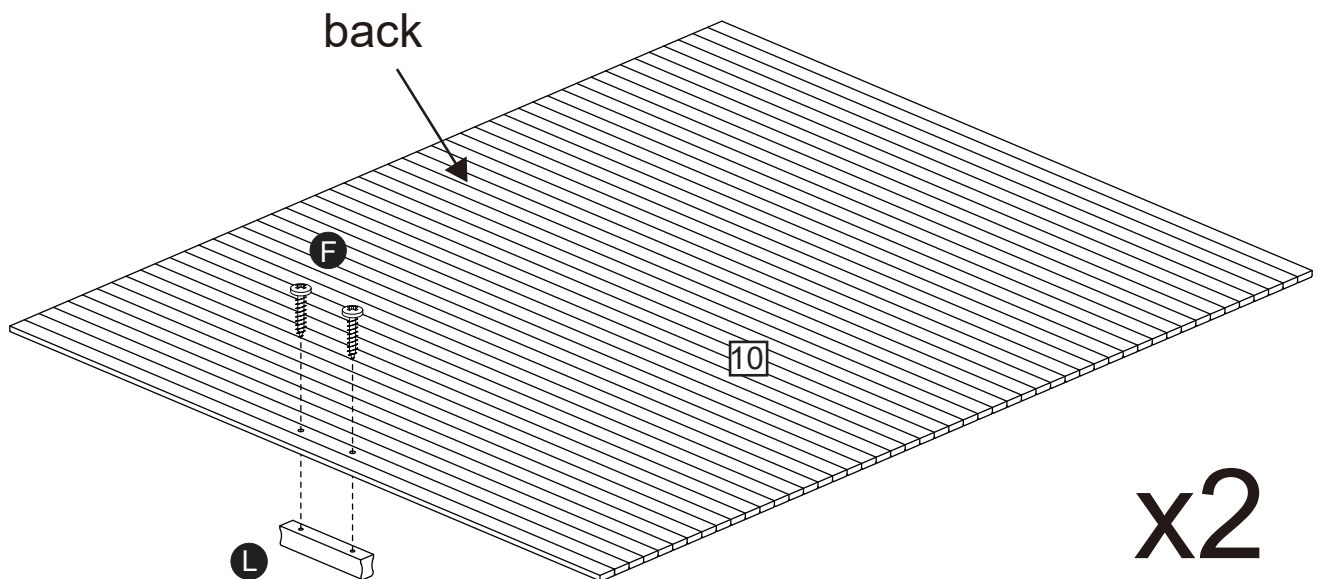

Assembly Instructions

Step 13

When installing the rolling shutter door, first clip the end of the shutter into the slot, then slide the shutter along the direction of the slot—this will ensure a smooth installation.

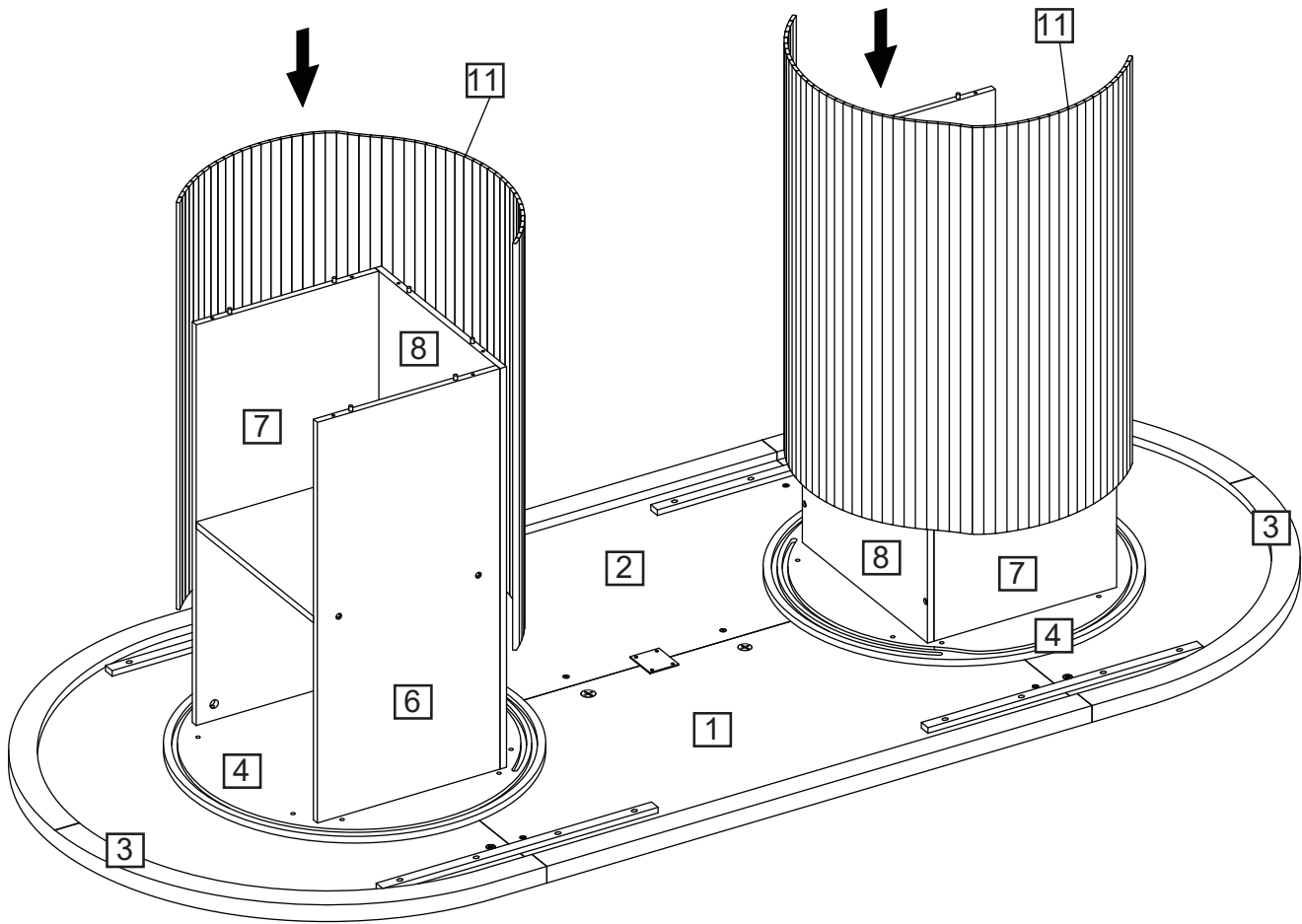

Insert part 11 into the card slots of part 4 respectively as shown in the figure

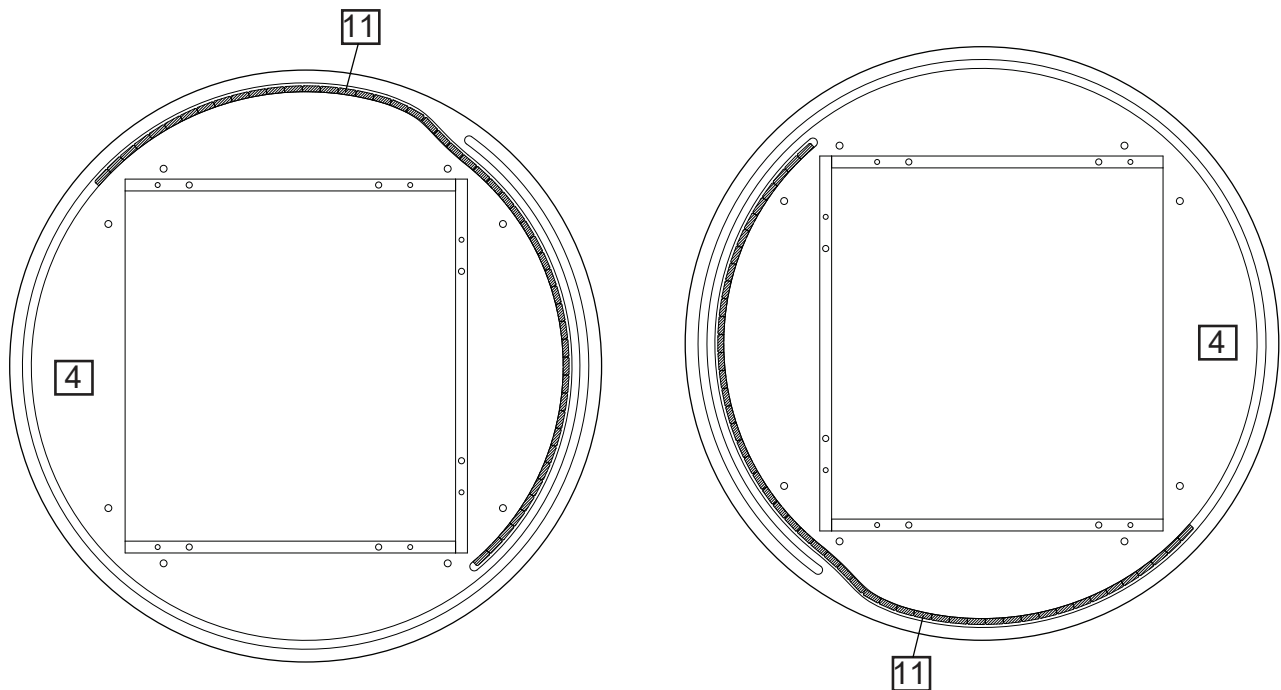

Assembly Instructions

Step 14

When installing the rolling shutter door, first clip the end of the shutter into the slot, then slide the shutter along the direction of the slot—this will ensure a smooth installation.

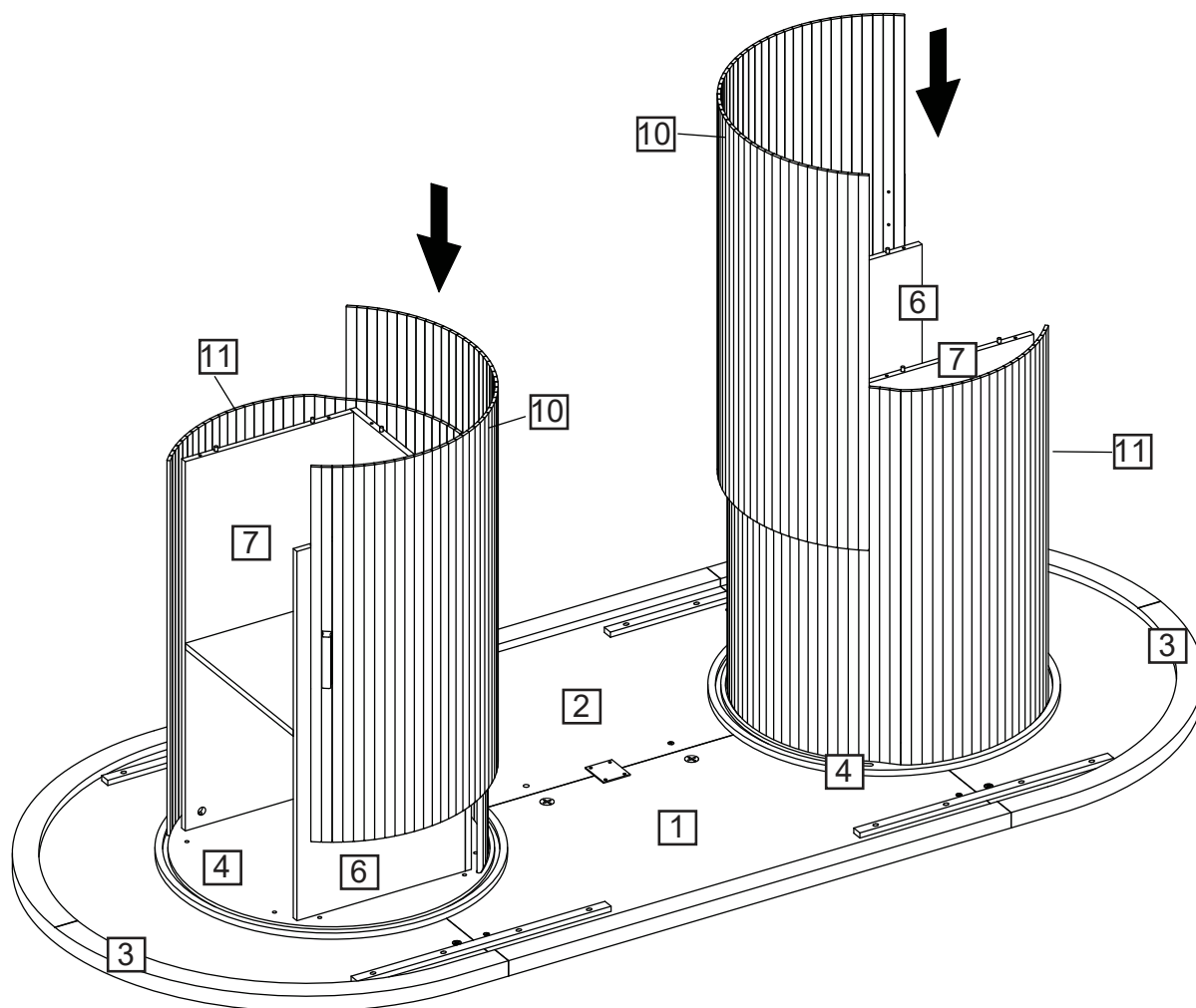

Insert part 10 into the card slots of part 4 respectively as shown in the figure

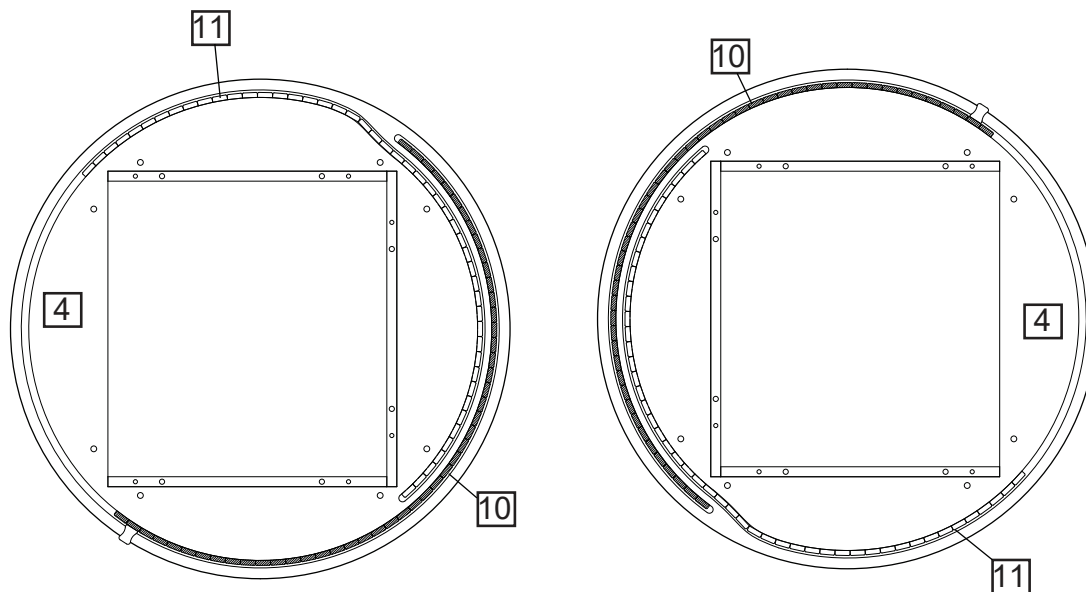

Assembly Instructions

Step 15

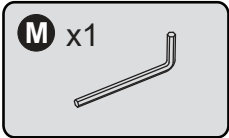
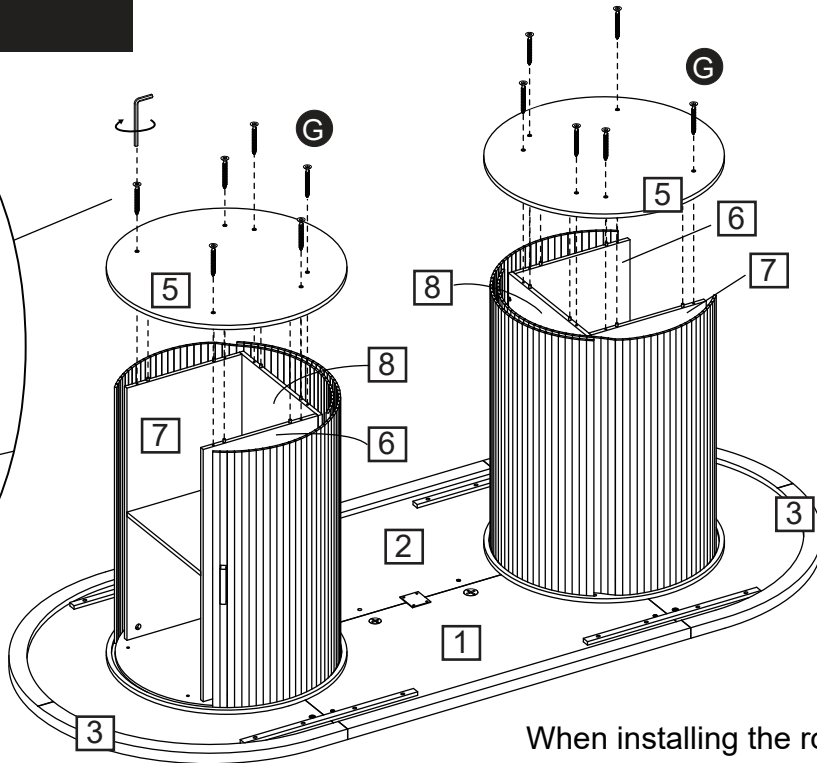
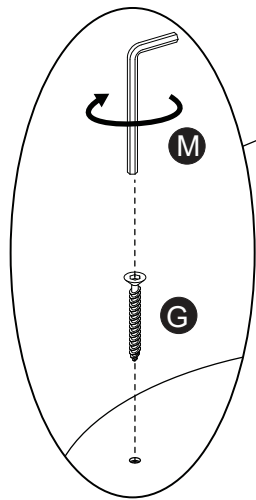

Use the screw (G) to assemble (Part 5) onto (Part 6), (Part 7), and (Part 8).

When installing the rolling shutter door, first clip the end of the shutter into the slot, then slide the shutter along the direction of the slot—this will ensure a smooth installation.

Step 16

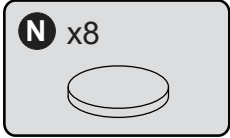
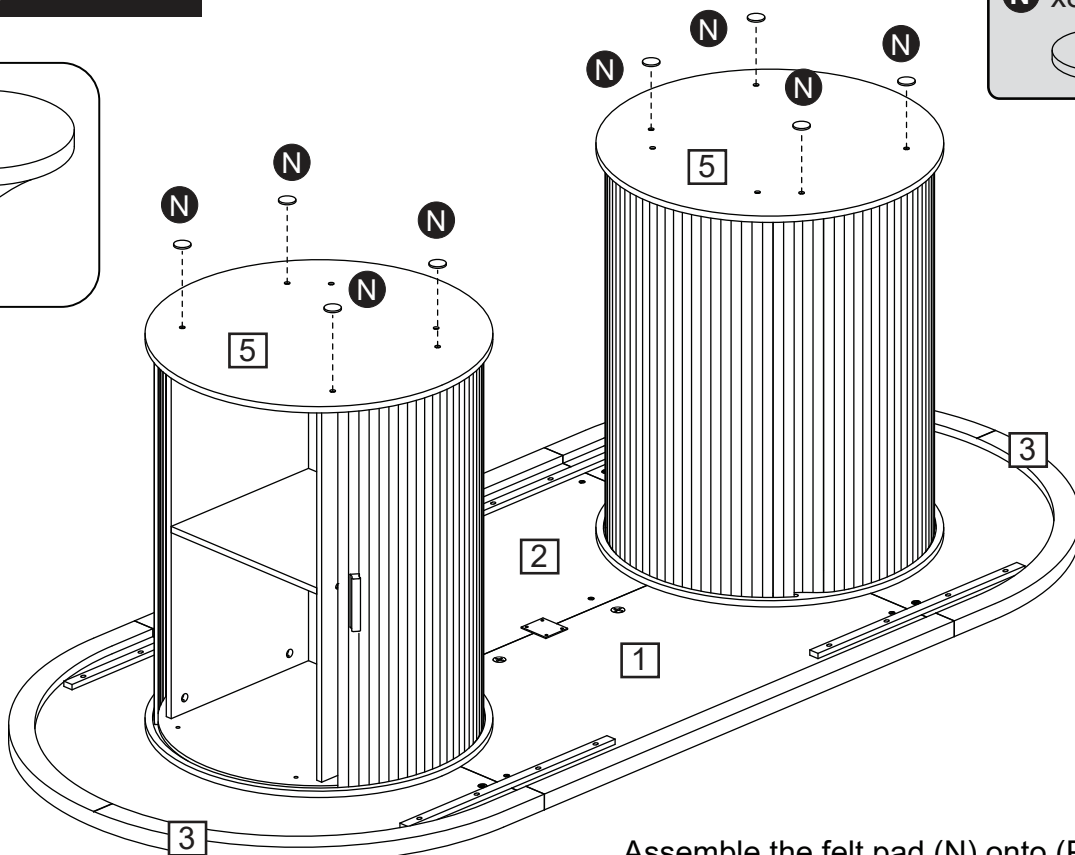
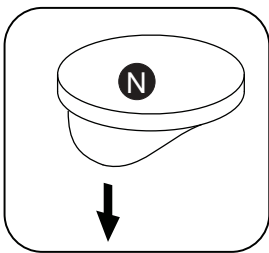

Assemble the felt pad (N) onto (Part 5).

Assembly Instructions

Step 17

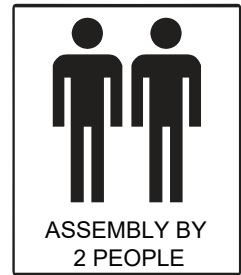
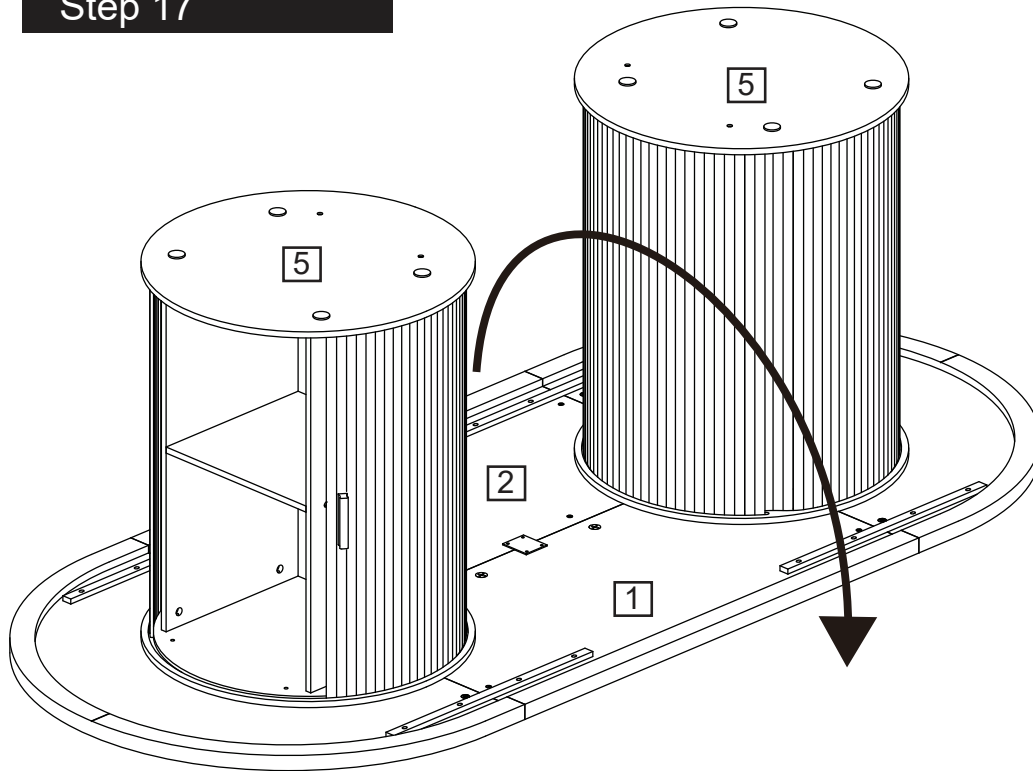

Flip the table forward 180 degrees. Close the door.

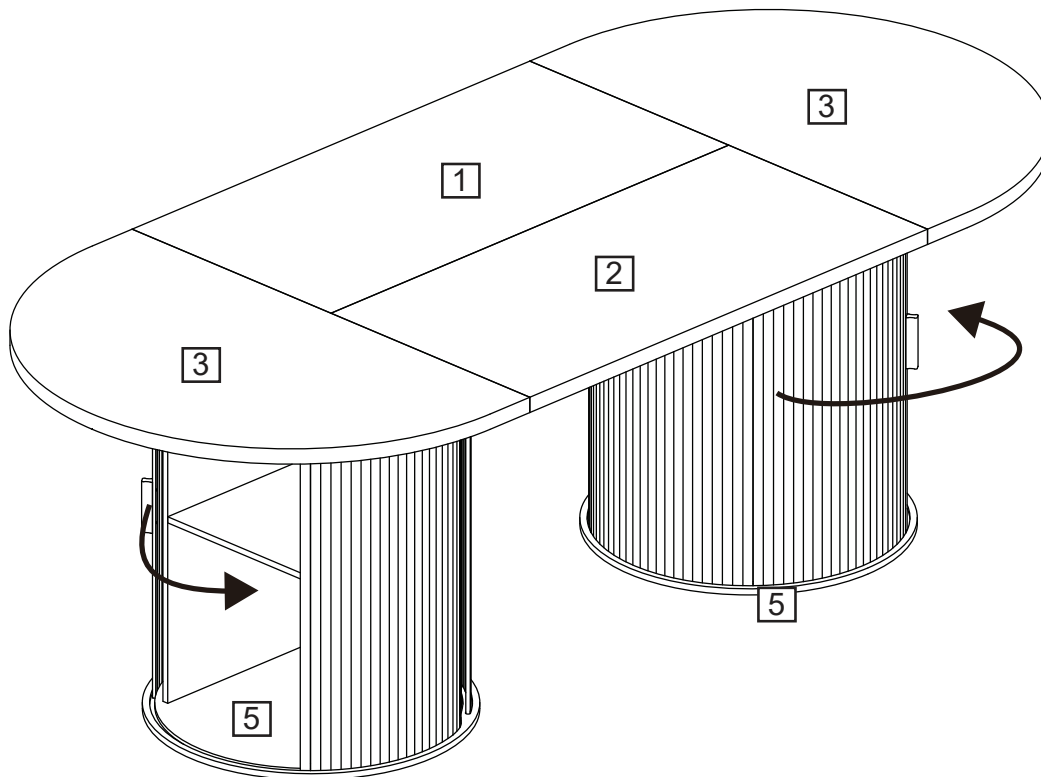

Assembly Instructions

Option 2 There are two types of opening directions for the table leg shelf:
For Option 1, please refer to Pages 12-18.
For Option 2, please refer to Pages 19-24.

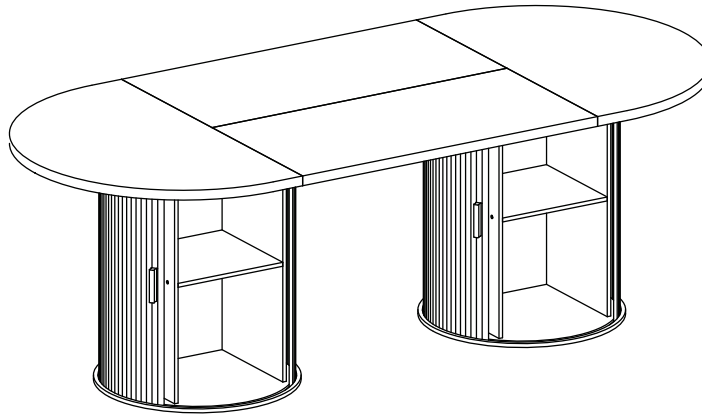

Step 9

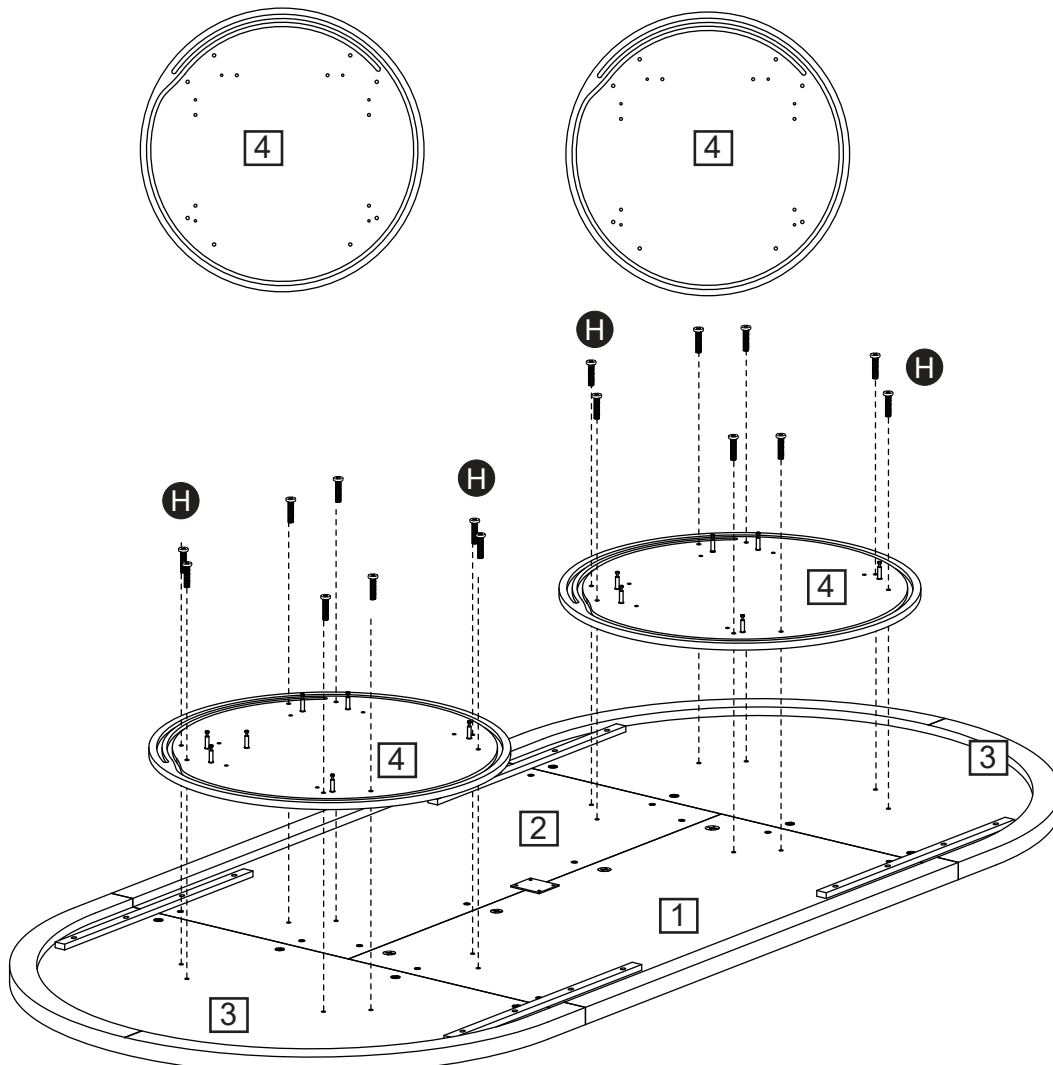

Use the bolt (H) to assemble (Part 4) onto (Part 1), (Part 2), and (Part 3).

Assembly Instructions

Step 10

Use the eccentric wheel (C) and dowel (A) to assemble (Part 6), (Part 7), and (Part 8) onto (Part 4).

A x12



C x12

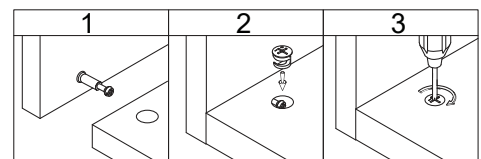
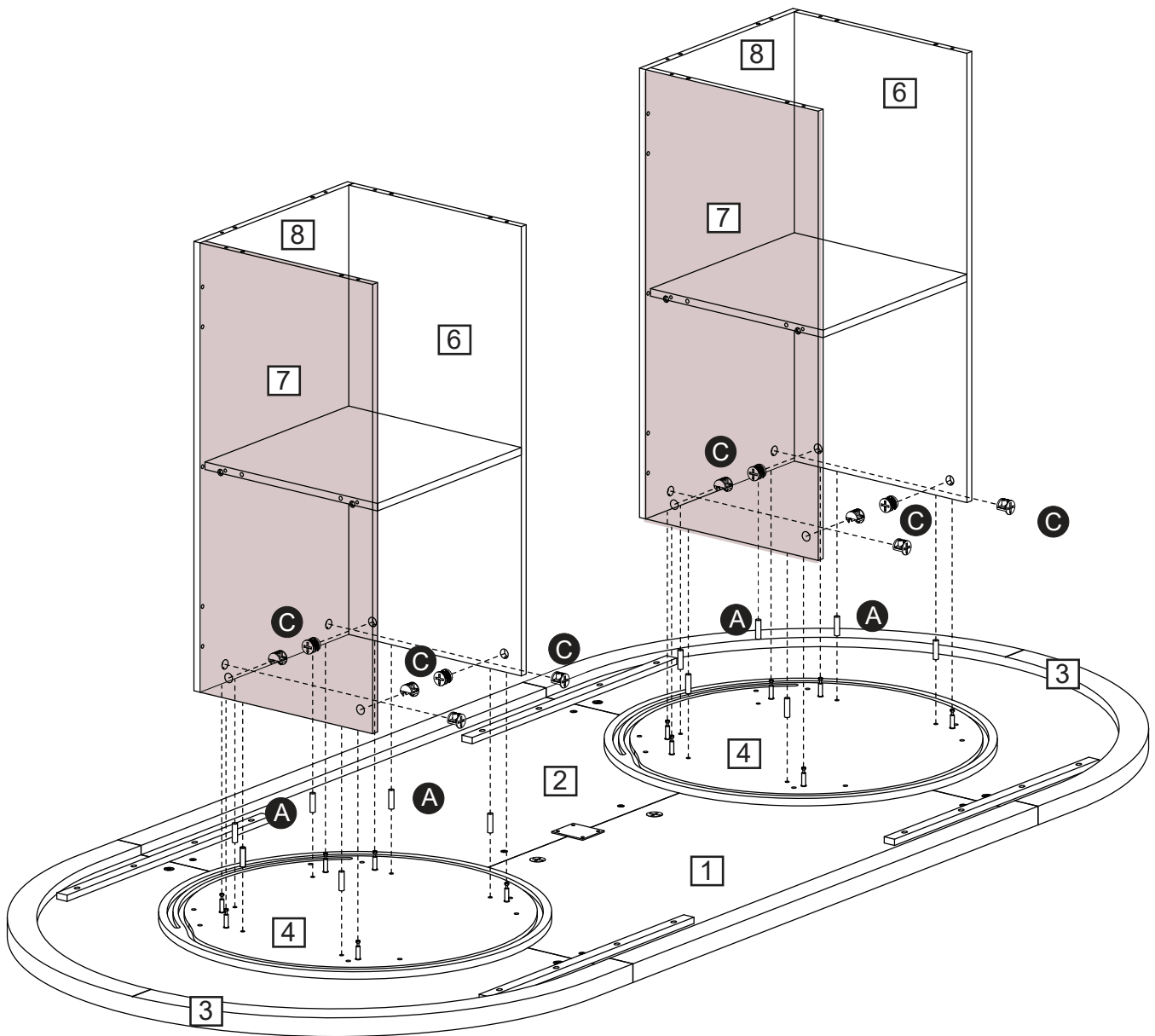

Assembly Instructions

Step 11

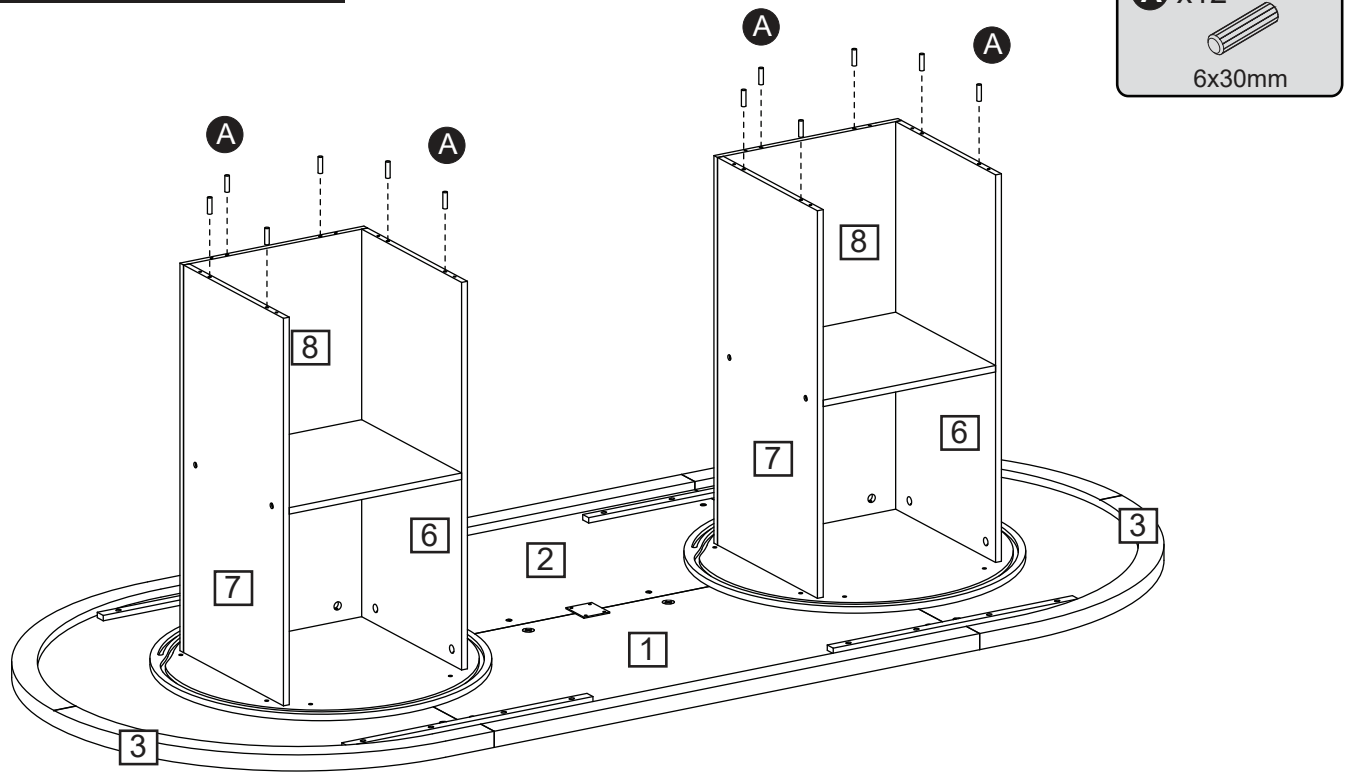

Insert the dowel (A) into (Part 6), (Part 7), and (Part 8).

Step 12

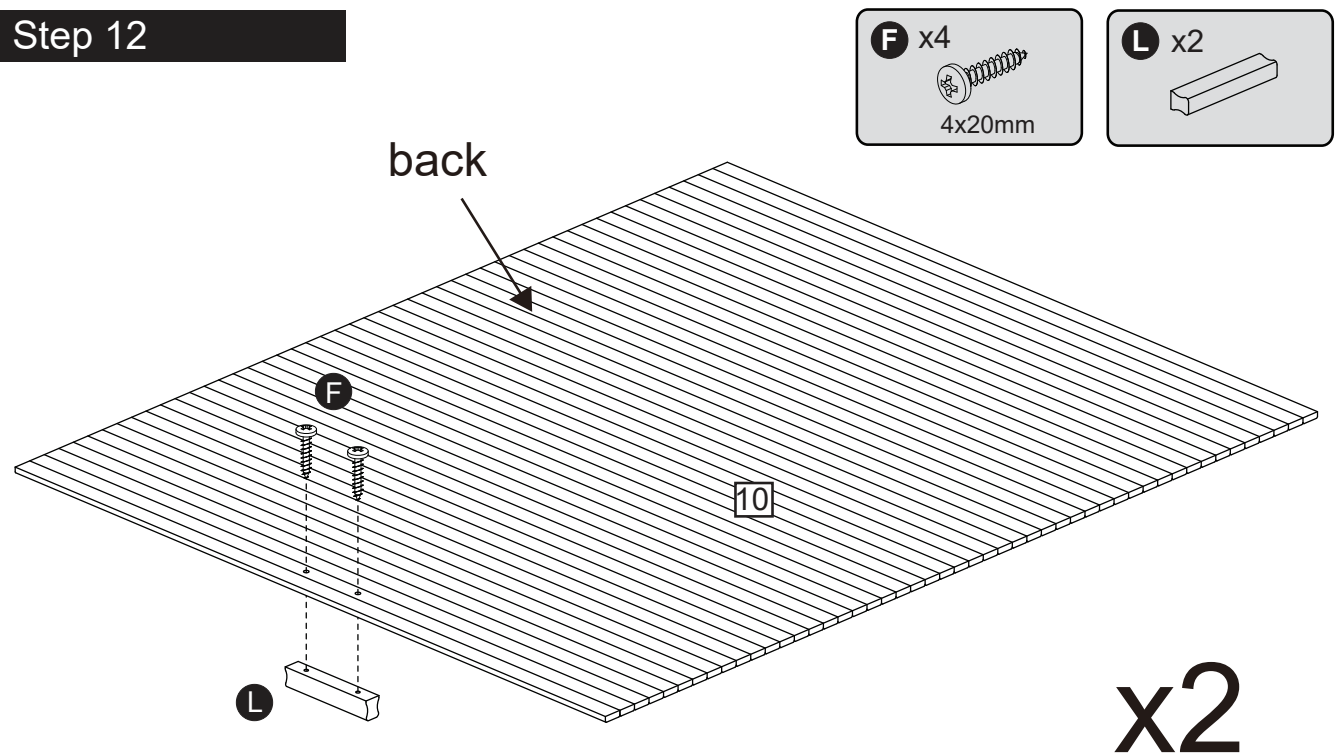

Use the screw (F) to assemble the handle (L) onto (Part 10).

Assembly Instructions

Step 13

When installing the rolling shutter door, first clip the end of the shutter into the slot, then slide the shutter along the direction of the slot—this will ensure a smooth installation.

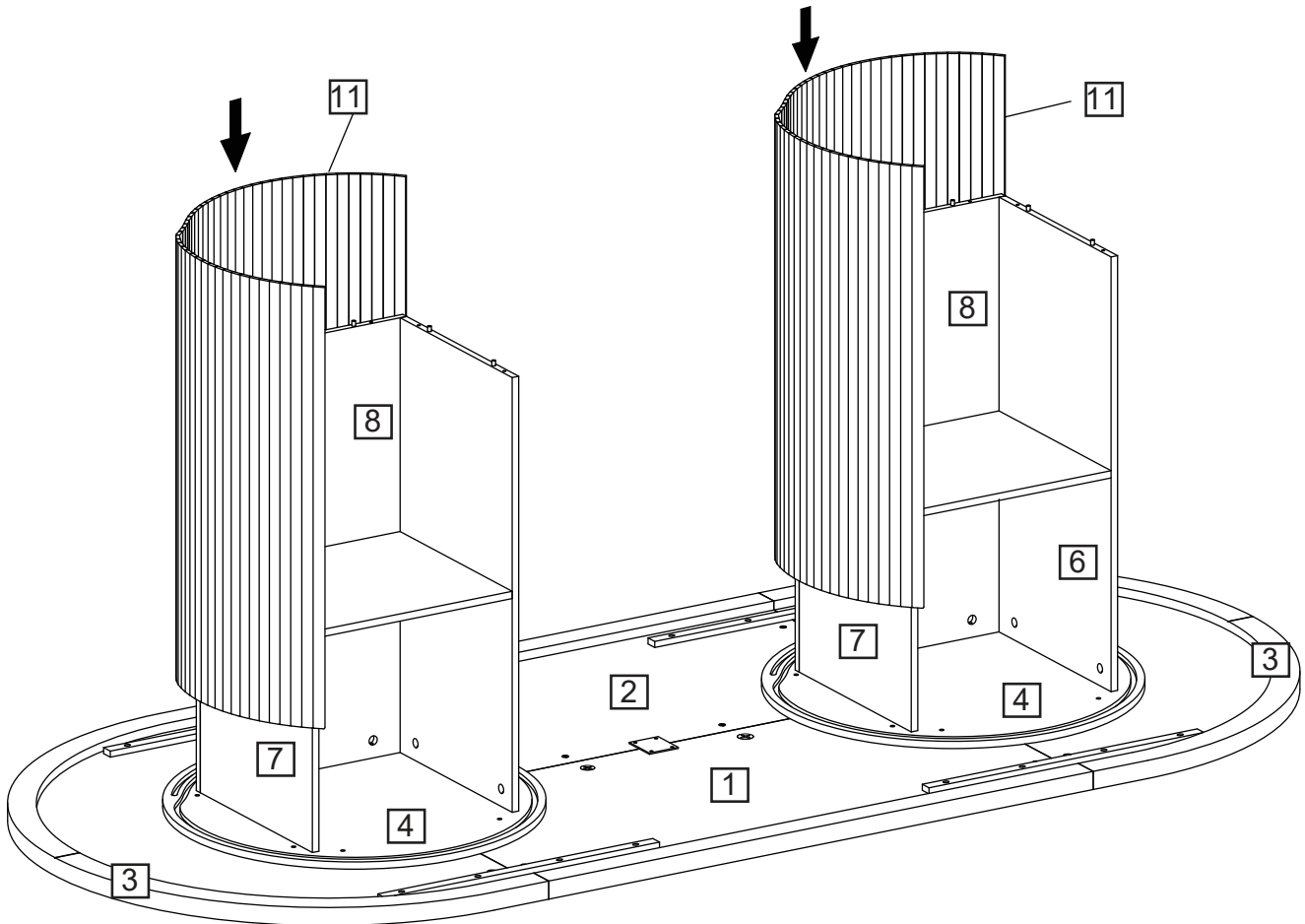

Insert part 11 into the card slots of part 4 respectively as shown in the figure

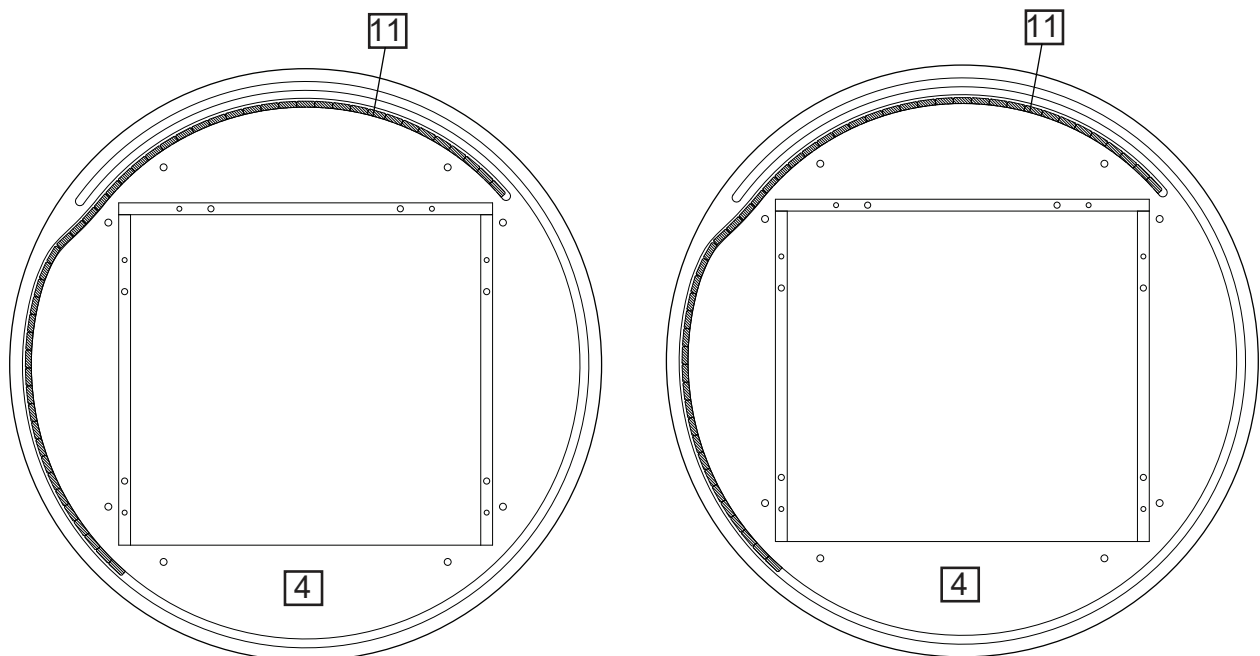

Assembly Instructions

Step 14

When installing the rolling shutter door, first clip the end of the shutter into the slot, then slide the shutter along the direction of the slot—this will ensure a smooth installation.

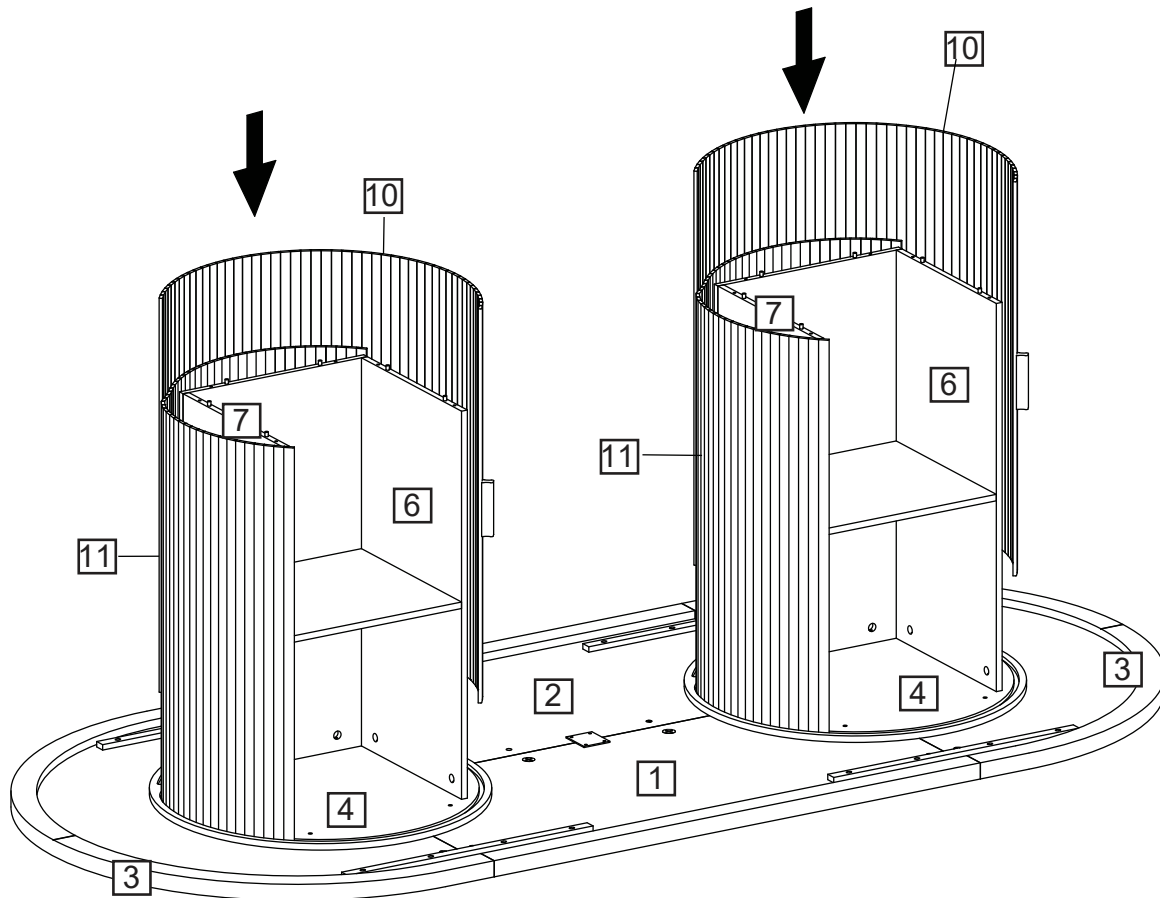

Insert part 10 into the card slots of part 4 respectively as shown in the figure

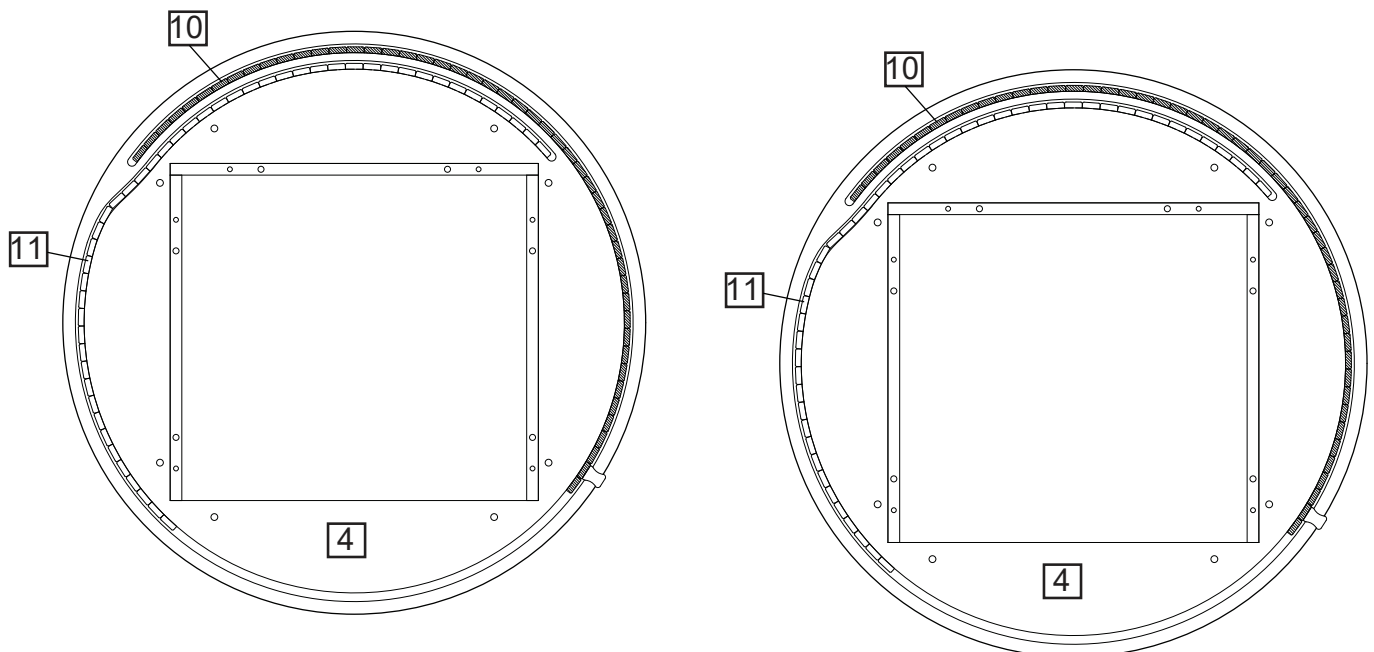

Assembly Instructions

Step 15

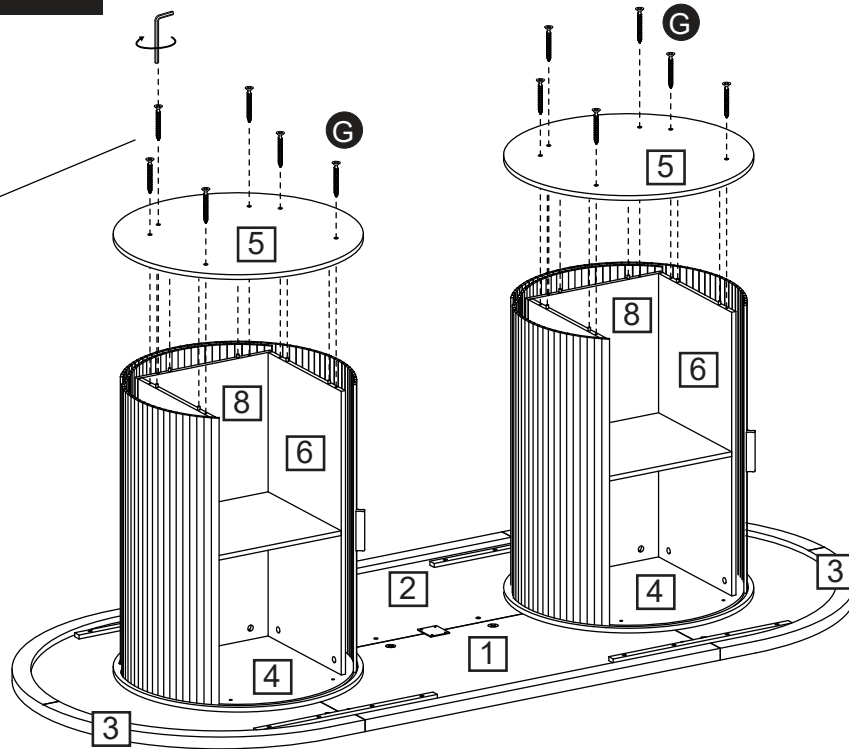
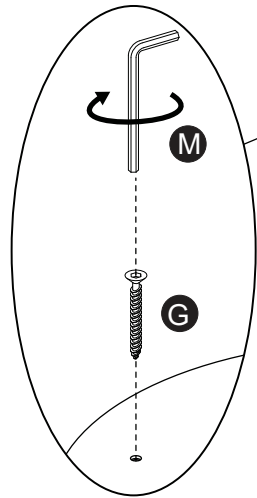

Use the screw (G) to assemble (Part 5) onto (Part 6), (Part 7), and (Part 8).

When installing the rolling shutter door, first clip the end of the shutter into the slot, then slide the shutter along the direction of the slot—this will ensure a smooth installation.

Step 16

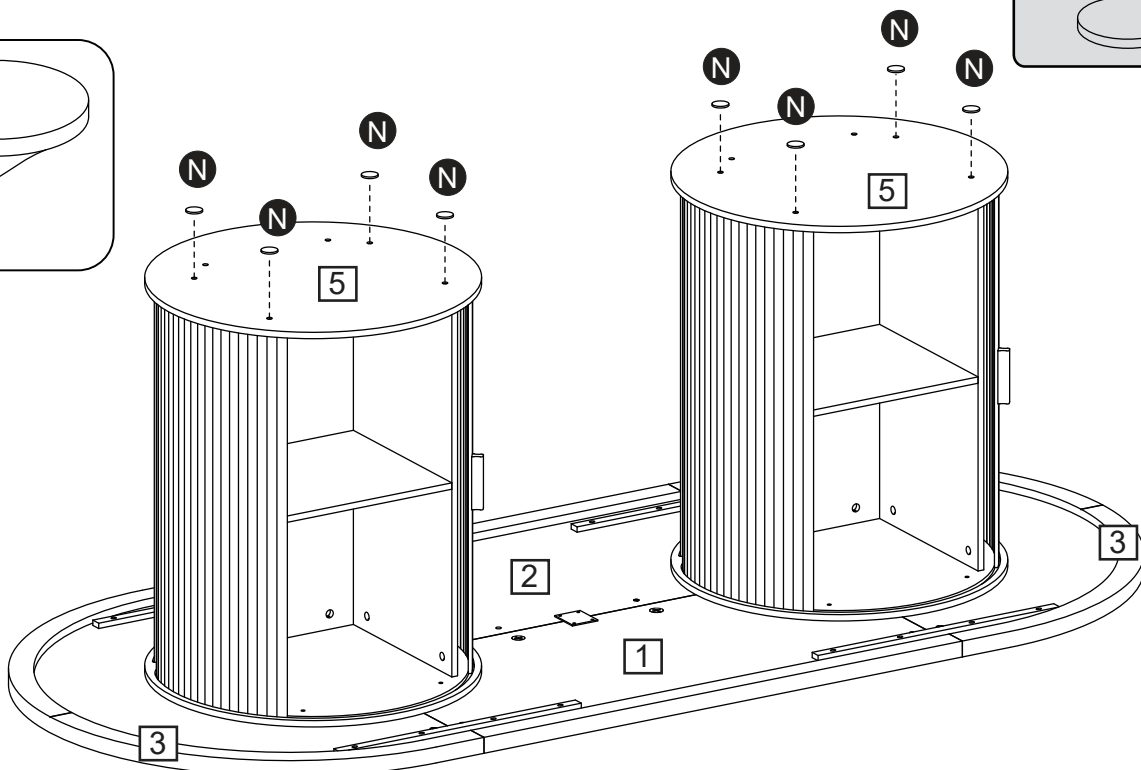
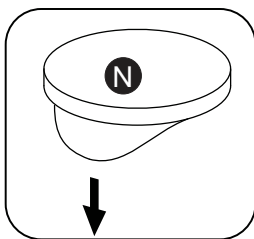

Assemble the felt pad (N) onto (Part 5).

Assembly Instructions

Step 17

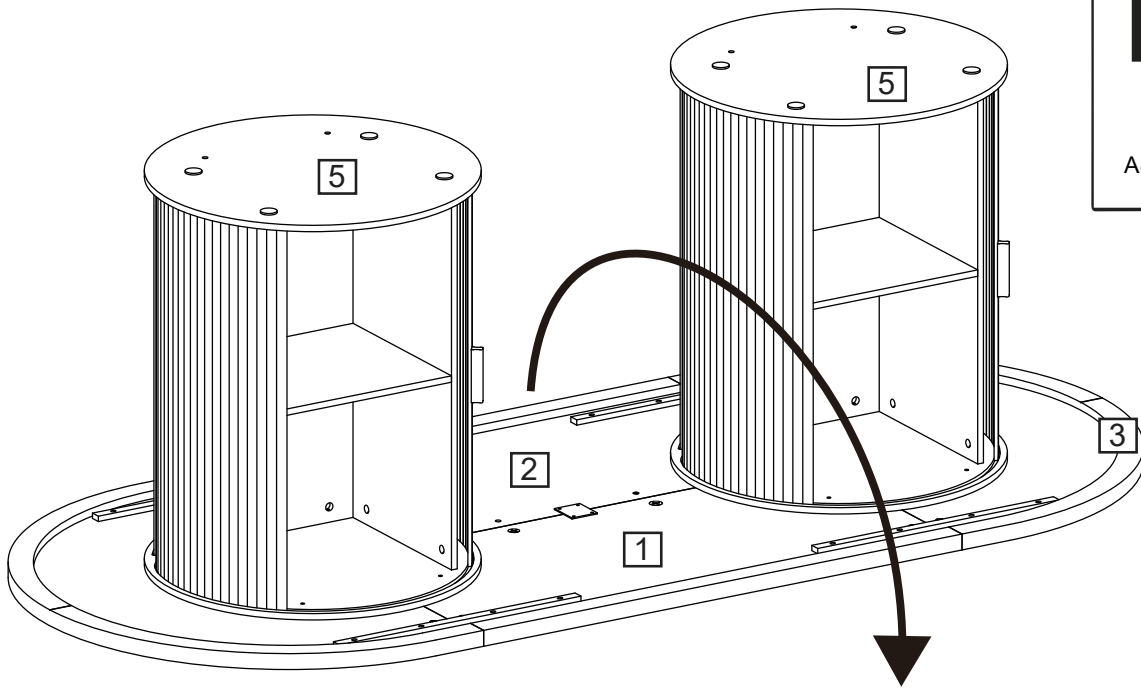
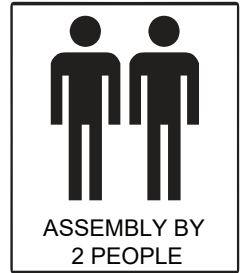

Flip the table forward 180 degrees. Close the door.

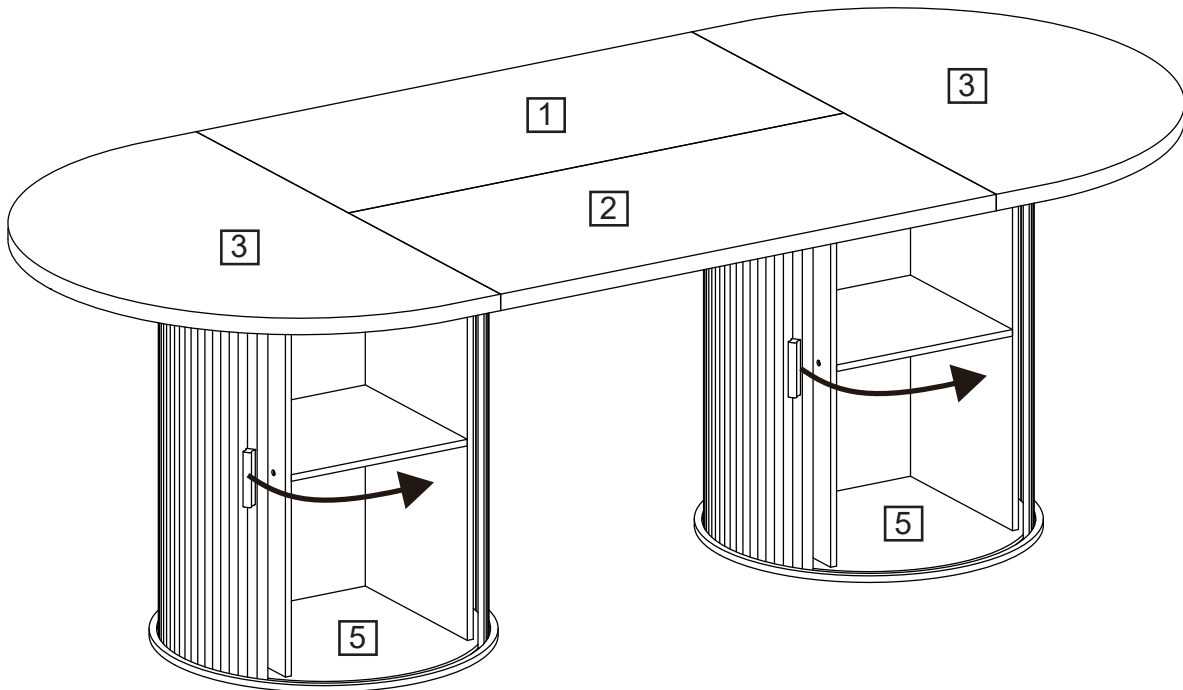

Assembly Instructions

Step 18

Move the side table correctly as shown in the diagram.

When moving the table, two people shall hold onto the long sides together and lift the table simultaneously.

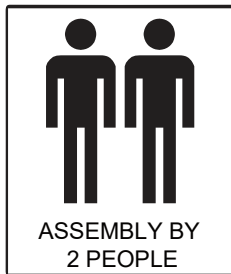
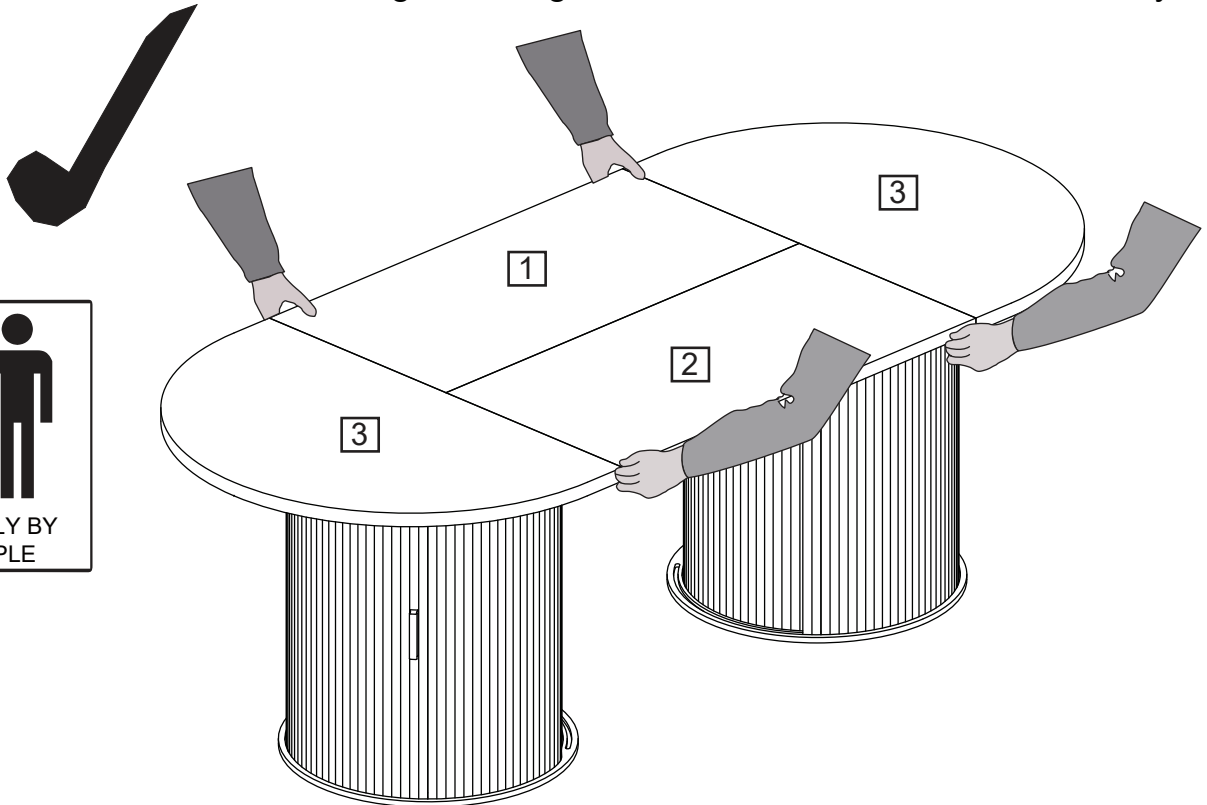

Do not lift or move the table from the short sides.

