

SPEC SHEET: 166-1327

32 GALLON EXPANDED RECEPTACLE *portable*
photo

Wt. 70 lbs



bottom / top view

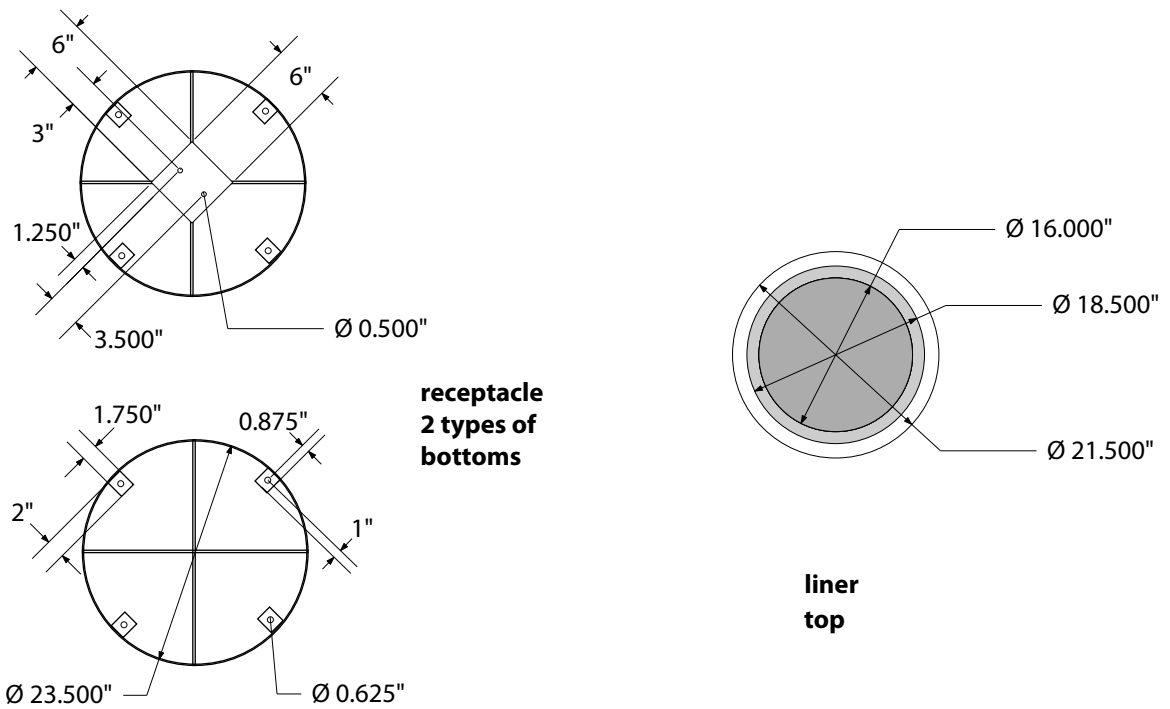

front view

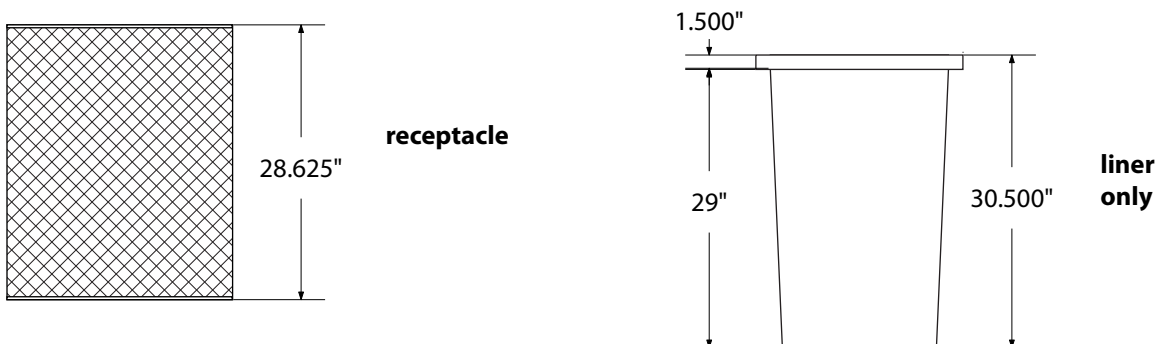

side / top view

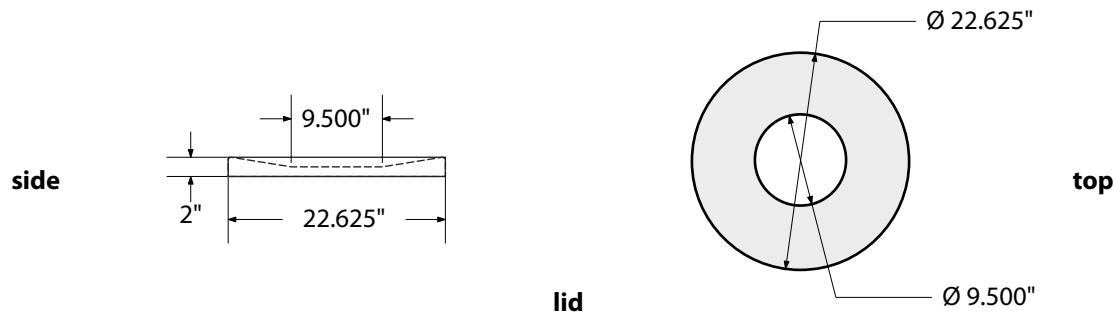

product finish



The functional surfaces of our furniture are covered in a copolymer-based thermoplastic powder coating. Thermoplastic is environmentally safe, the coating will never fade, crack, peel, warp, or discolor for the life of the product. Thermoplastic is applied at a thickness of 25-30 mils.



The liner that comes with this receptacle is made from black polyethylene plastic.

mounting types

P = Portable : no mount

SM = Surface Mount:
concrete anchors
through taps welded
to legs

2 Option
anchor bolts attach
to surface receptacle
mount

IG= In-Ground:
anchor bolts attach
to in-ground
receptacle mount

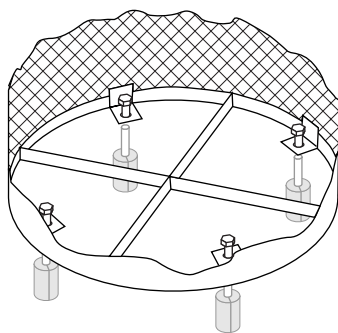

SURFACE MOUNT

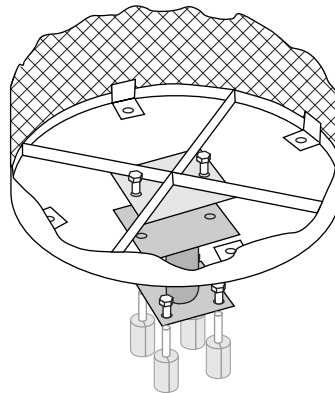

SURFACE MOUNT

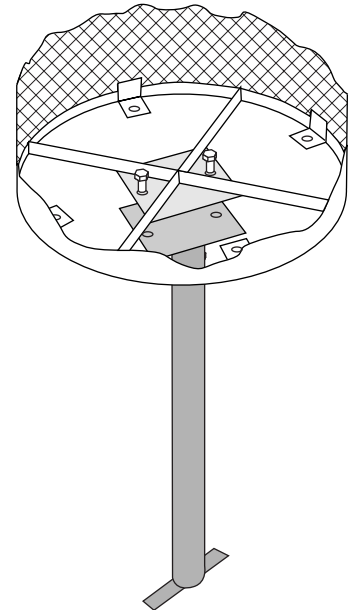

IN-GROUND

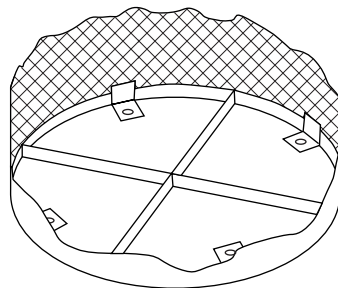

PORTABLE

Thermoplastic — the Smart Choice.

Our 166- series thermoplastic outdoor furniture is covered in a copolymer-based thermoplastic coating that is UV-stabilized and is highly resistant to both hard wear and severe weather. Thermoplastic is environmentally safe. The coating will not fade, crack, peel, warp, or discolor for the life of the product. Thermoplastic can be easily repaired. Cuts are repaired by heating the affected area with an industrial heat gun. The thermoplastic will rebound itself. The properties of thermoplastic also make spray painting pointless for vandals. Simply wash the product with a standard industrial cleaner. The tables, benches, receptacles, and accessories are available in several different thermoplastic-coated metal patterns:

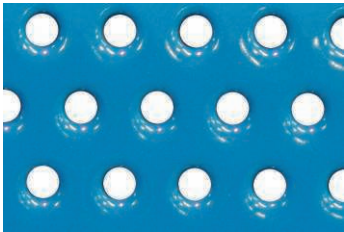

Perforated Metal

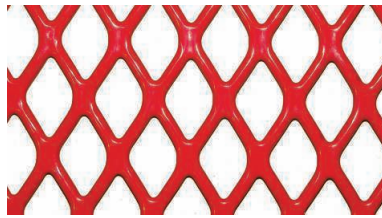

Expanded Metal



Wire



Ribbon

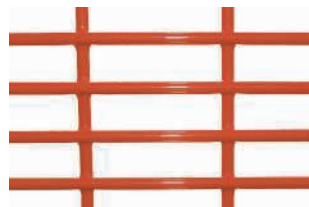

Rod



Diamond Pattern

For more information on 166 series Thermoplastic Products please contact
sales@theparkcatalog.com or Call 1-888-447-2401
www.theparkcatalog.com

Thermoplastic Is Graffiti Proof!

1. If spray paint is applied to the thermoplastic coating, it is very easy to remove using a common aerosol.
2. Simply spray WD-40™ on the offending graffiti.
3. Watch as the dried paint is quickly eliminated from the thermoplastic surface.
4. It's simple and SAFE!

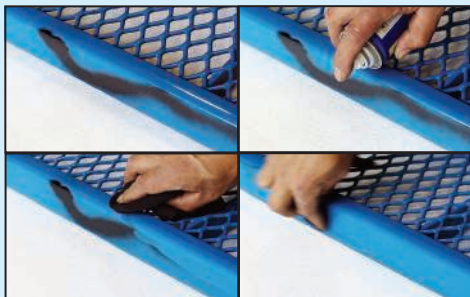

166 series Thermoplastic color choices:

Black		Red	
Orange		Yellow	
Green		Black Green	
Blue		Navy	
Purple		Burgundy	
Brown		Beige	
Gray		Granite	
Sandstone			