

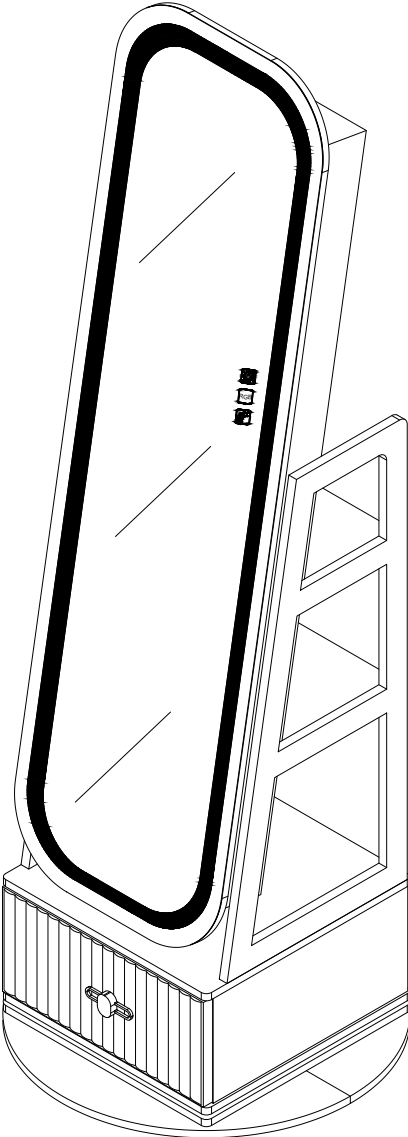

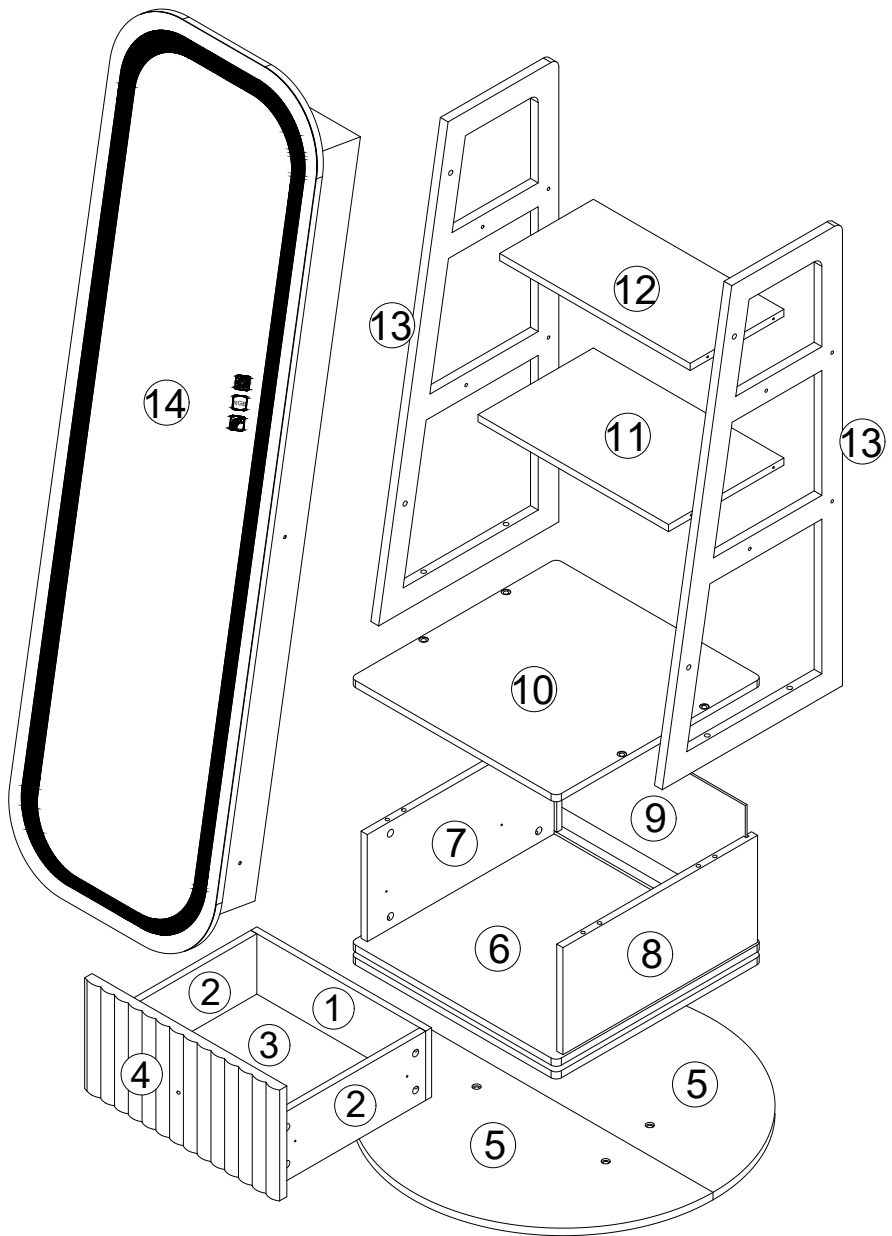

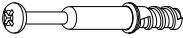













MIRROR JEWELLERY CABINET





Accessories list

A		Two In One Screw (6x28mm)	16pcs +2pcs
B		Two In One Nut (10x12mm)	16pcs +2pcs
C		Wood Chipping (6x30mm)	8pcs +2pcs
D		Screw & Handle (4x18mm)	1pcs 1pcs
E		Screw & Guide (3x12mm) 12 inches	10pcs +2pcs 2pcs
F		Screw & Hooks (3x12mm)	4pcs +2pcs 2pcs
G		Screw (6x25mm)	4pcs +1pcs
H		Screw (6x50mm)	4pcs +1pcs
I		Screw (5x40mm)	8pcs +1pcs
Anti tipping hardware			
J	 x1  x1 (3.5x12mm)	 x2  x1 (4x45mm)	 x1
K		The key	1pcs
L		Non-slip pads (370x6x6mm)	2pcs +1pcs
M		Screw (6x22mm)	4pcs +1pcs
N		The power adapter (12V 3A)	1pcs
O		Remote control	1pcs

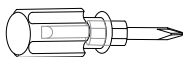

1pcs

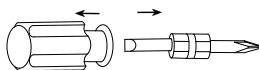

Double-head screwdriver, use as required

2

Use parts A and B

Step 1

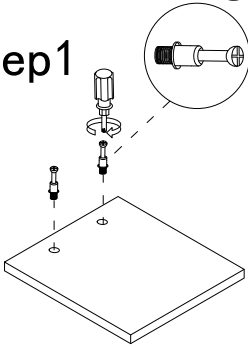

Step 2

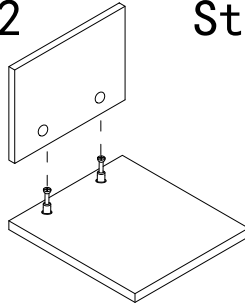

Step 3

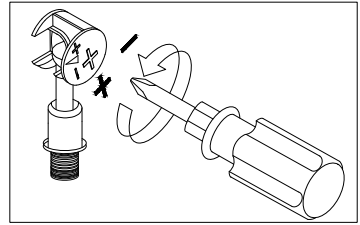
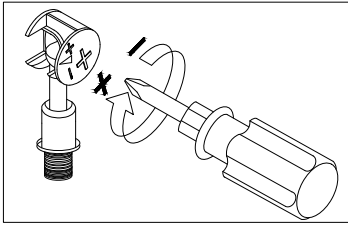
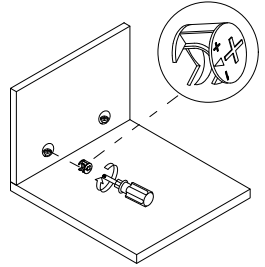

Use a screwdriver to lock in the direction of the "+" sign

Disassemble along the direction of "-" sign

Step 1

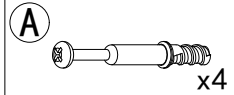
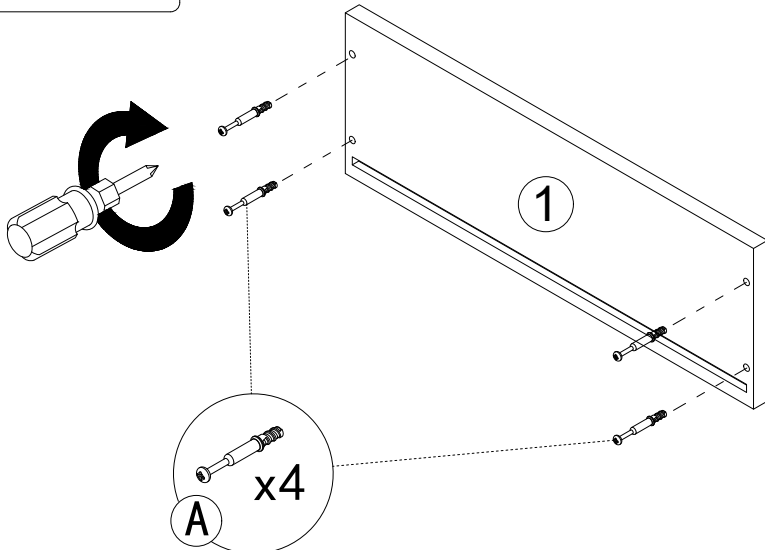

Step 2

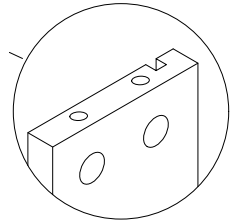
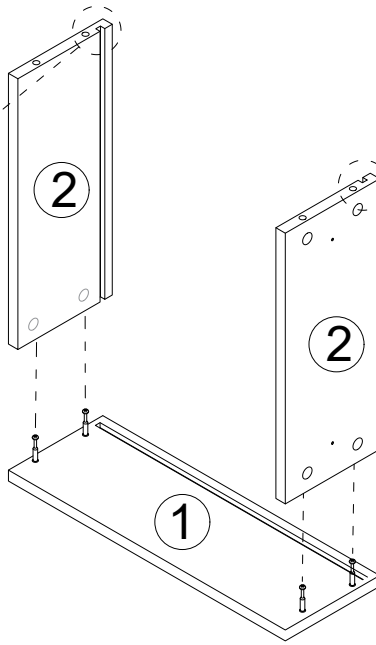
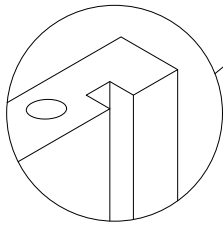

Step 3

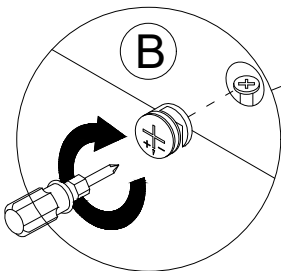
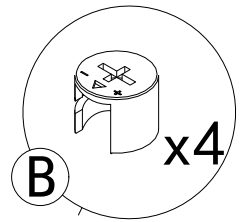
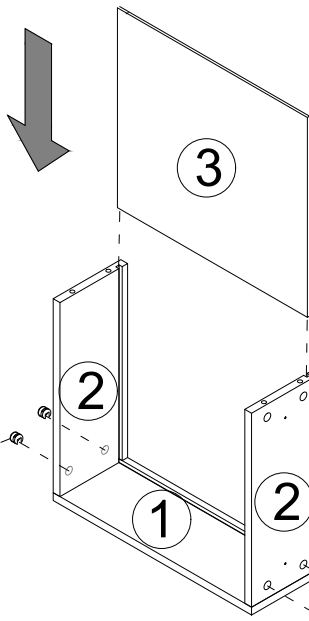

Step 4

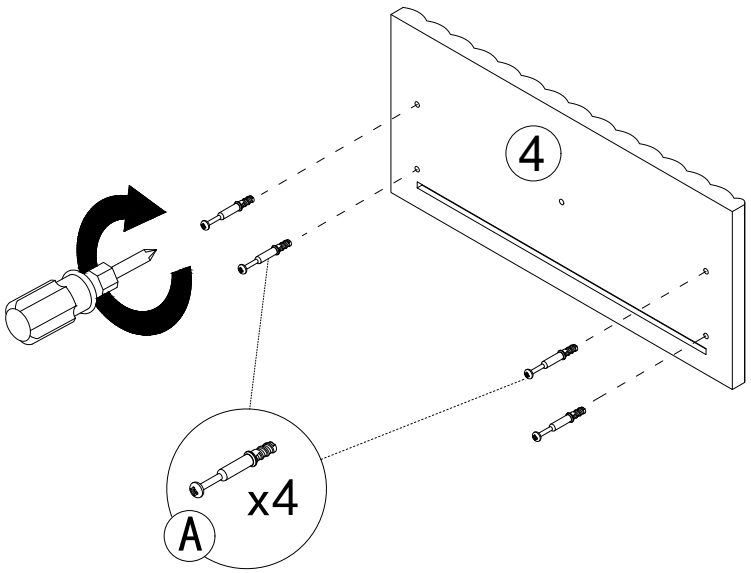
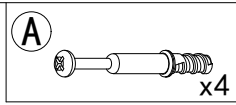

Step 5

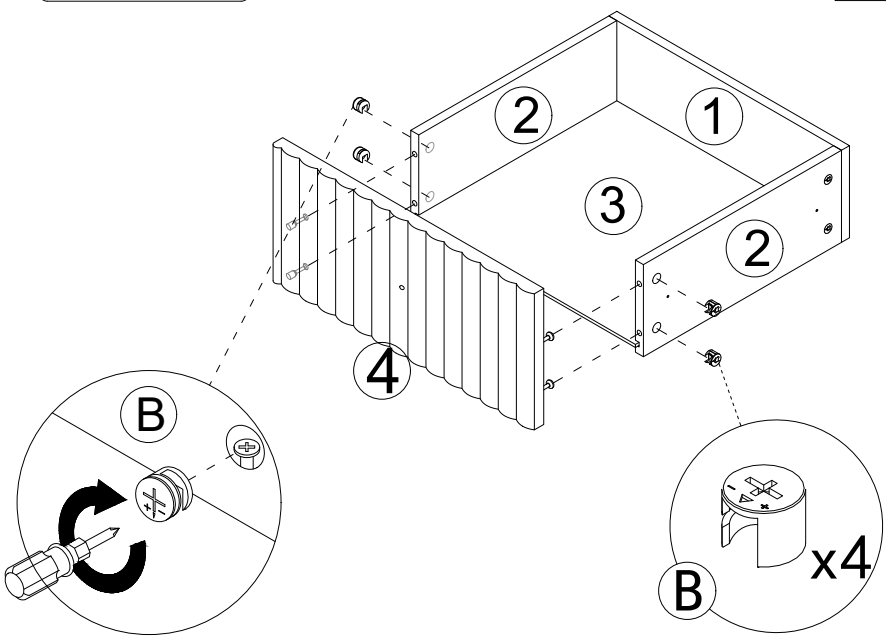

Use parts (E)

Drawer rail breakdown diagram

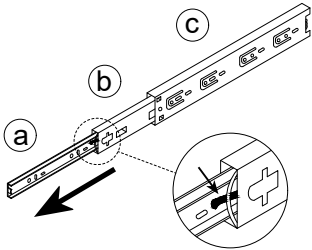

Step 1 : Pull the rails apart

Step 2 : Push the nylon buckle outward (a)

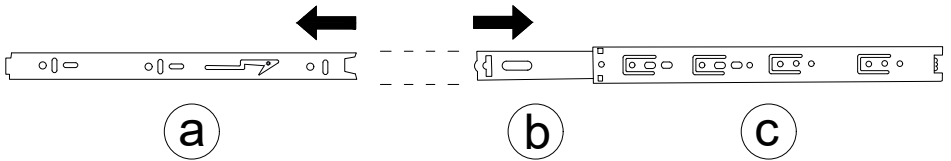
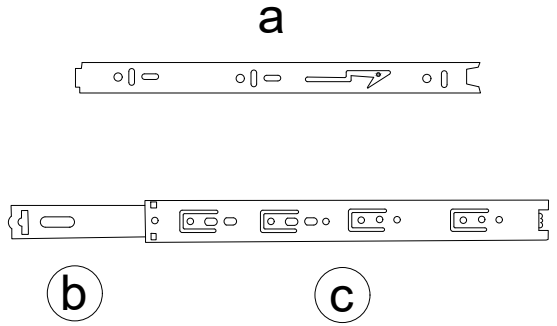

Step 6

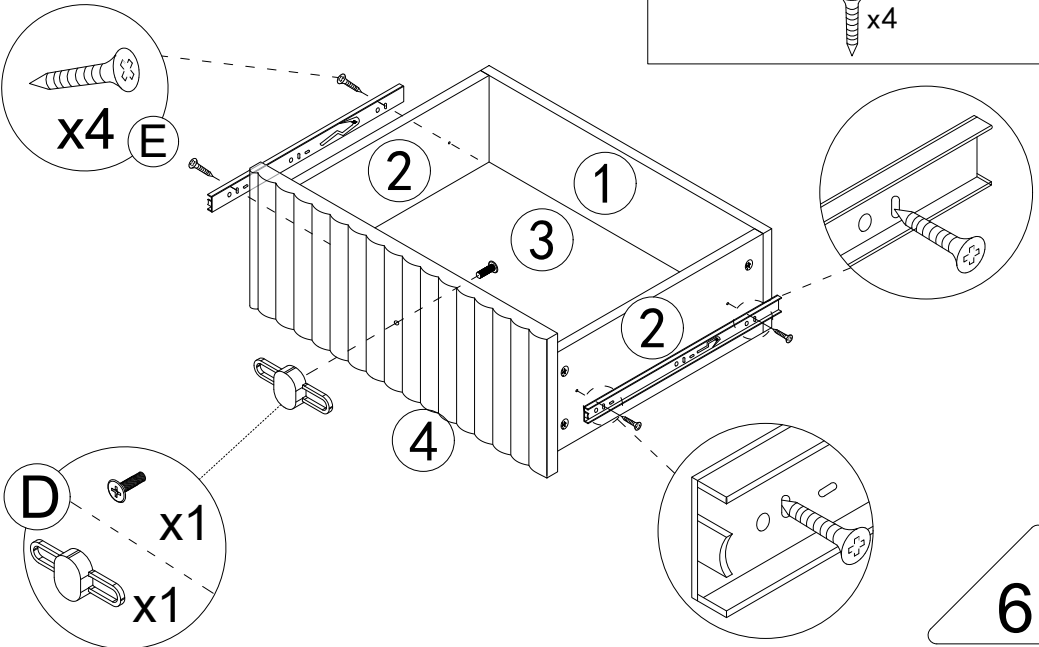
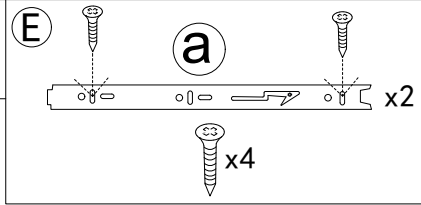
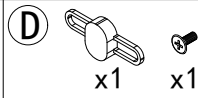

Step 7

M



x4

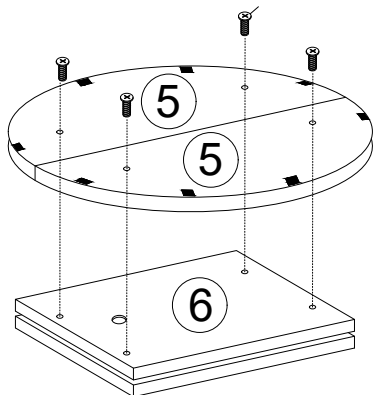
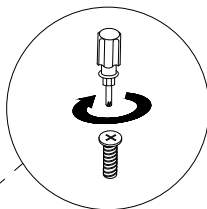
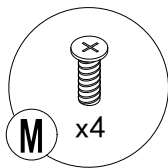

Turn the plank and screw it on

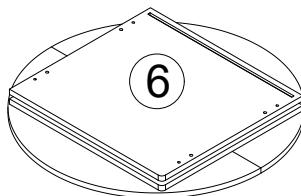

Step 8

A

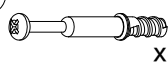

x4

C

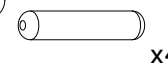

x4

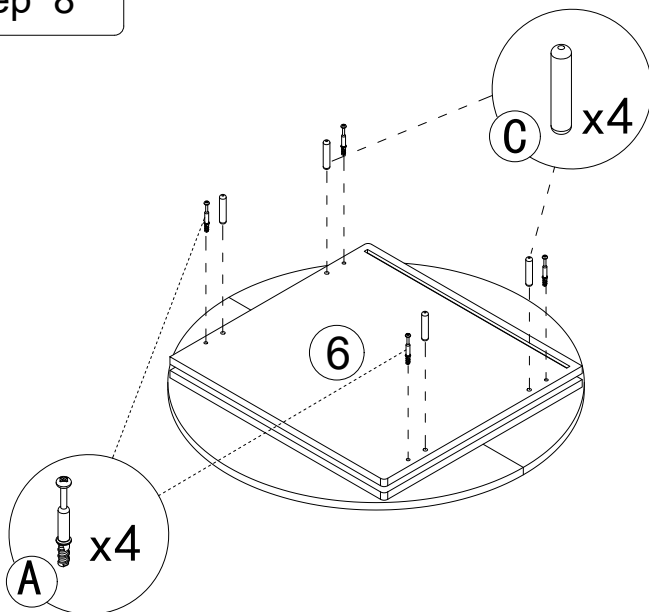

A

x4

C

x4

Step 9

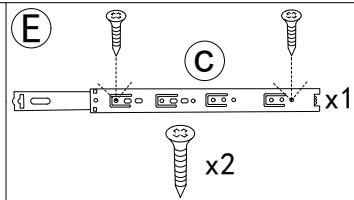
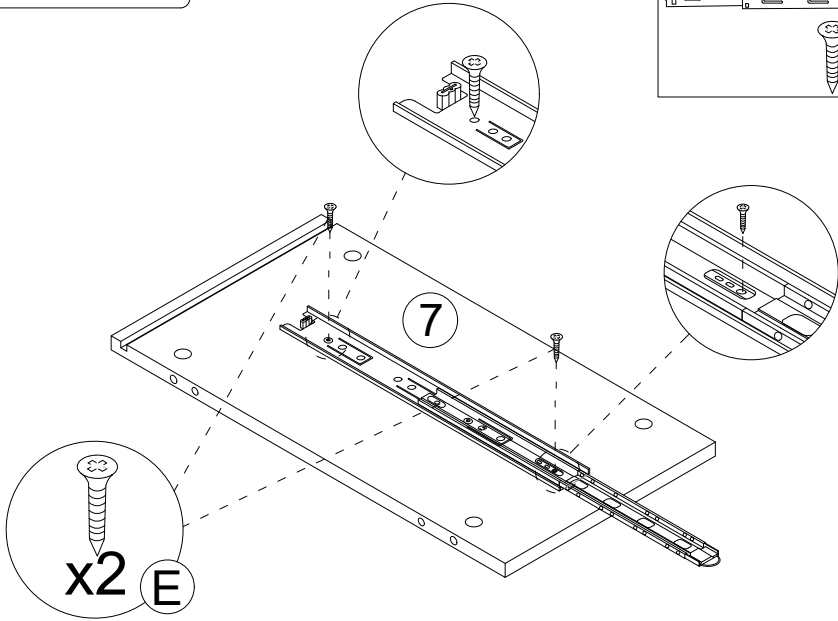

Step 10

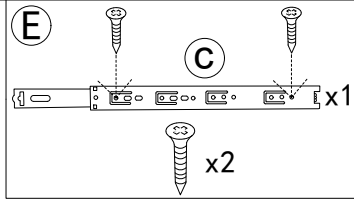
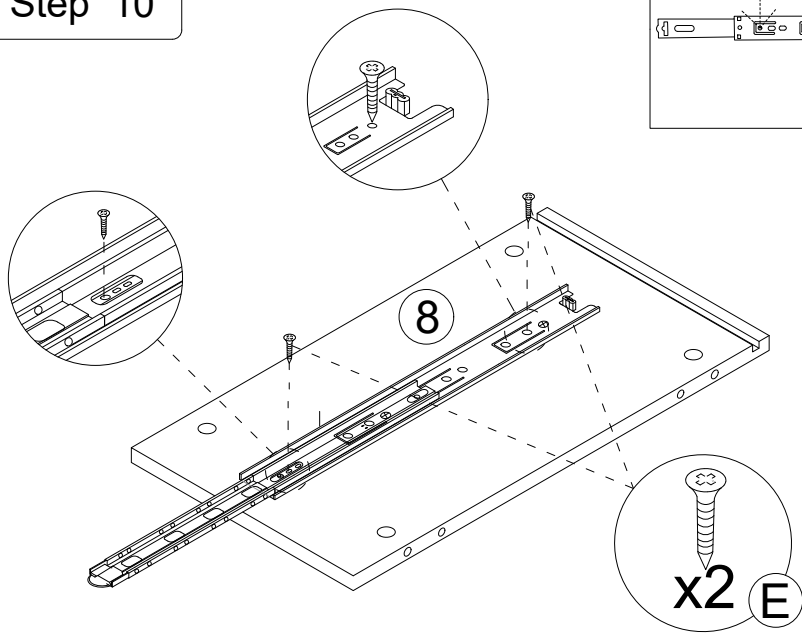

Step 11

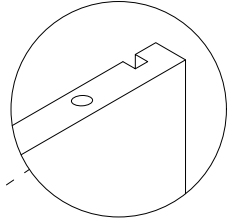
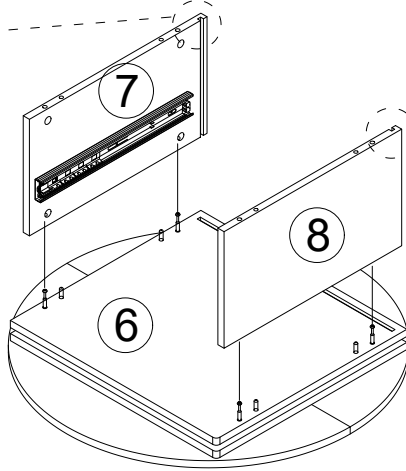
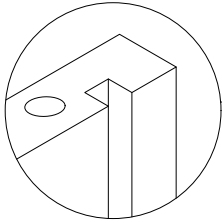

Step 12

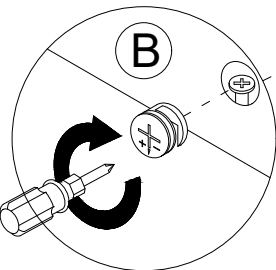
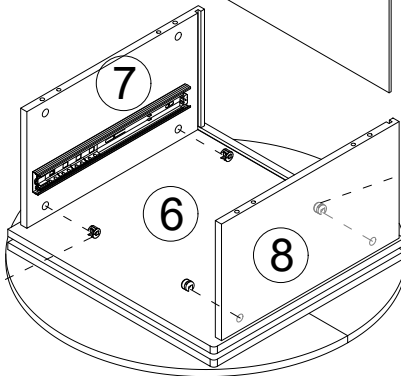
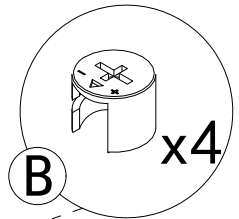
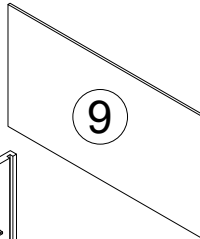

Step 13

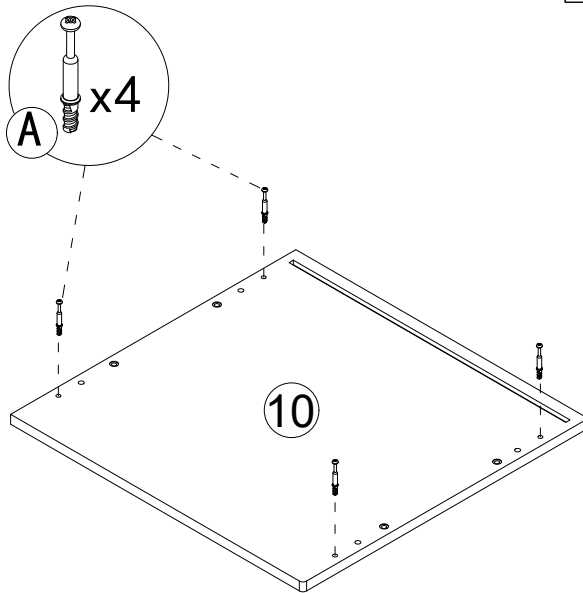
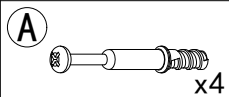

Step 14

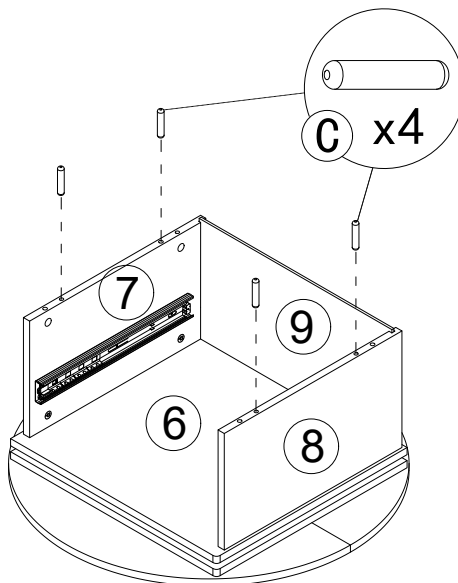
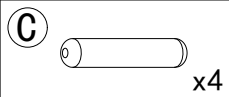

Step 15

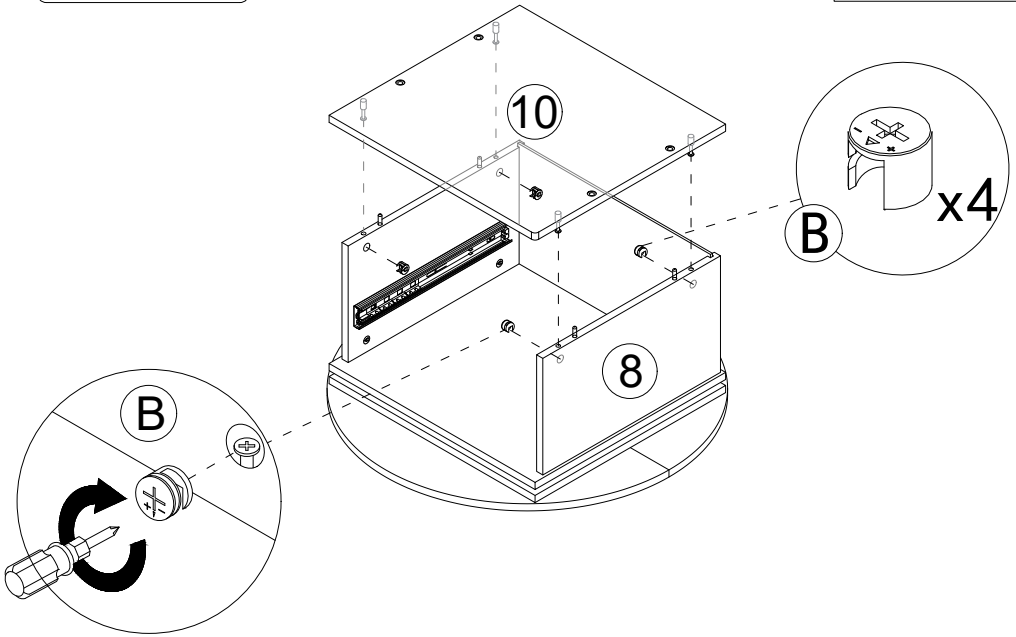

Step 16

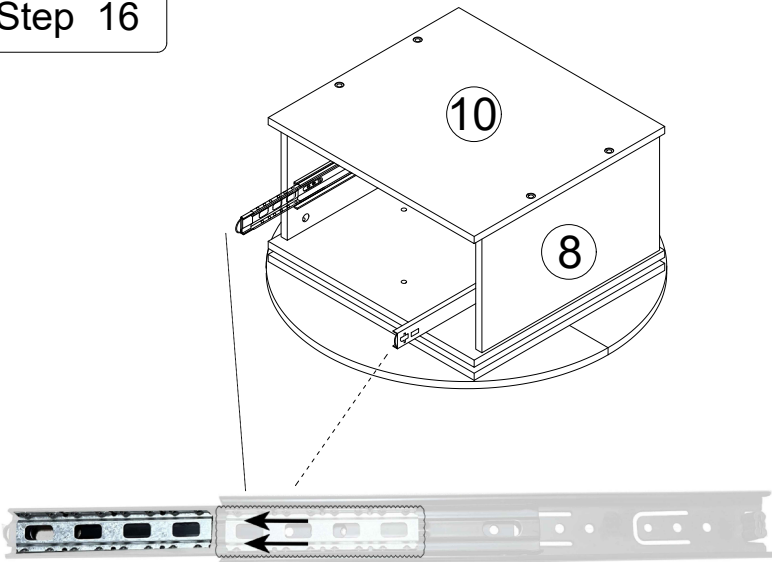

As shown, When installing the drawer, pull the guide rail out first, Slide beads are also pulled out.

Step 17

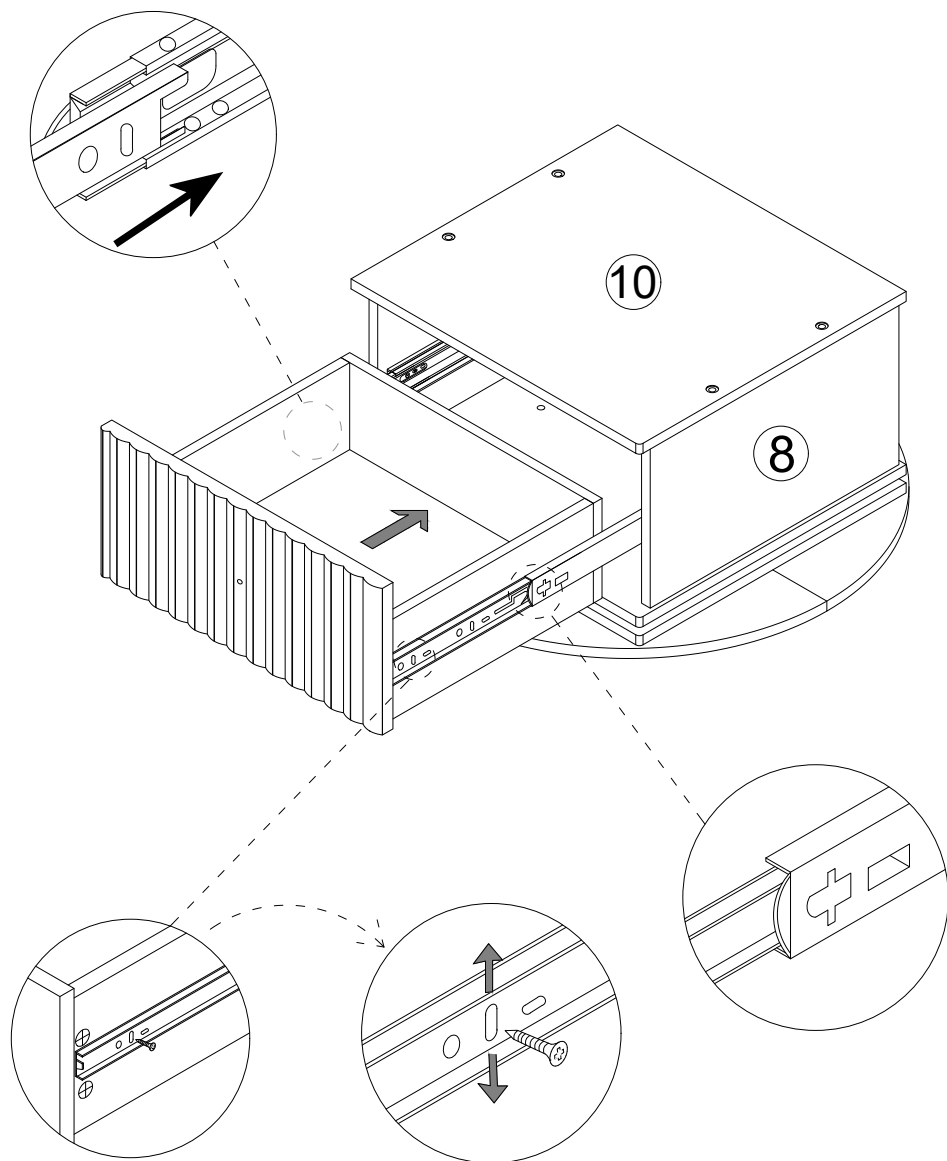

If a large gap is found after installing the drawer the slide rail can be moved up and down to adjust the gap

Step 18

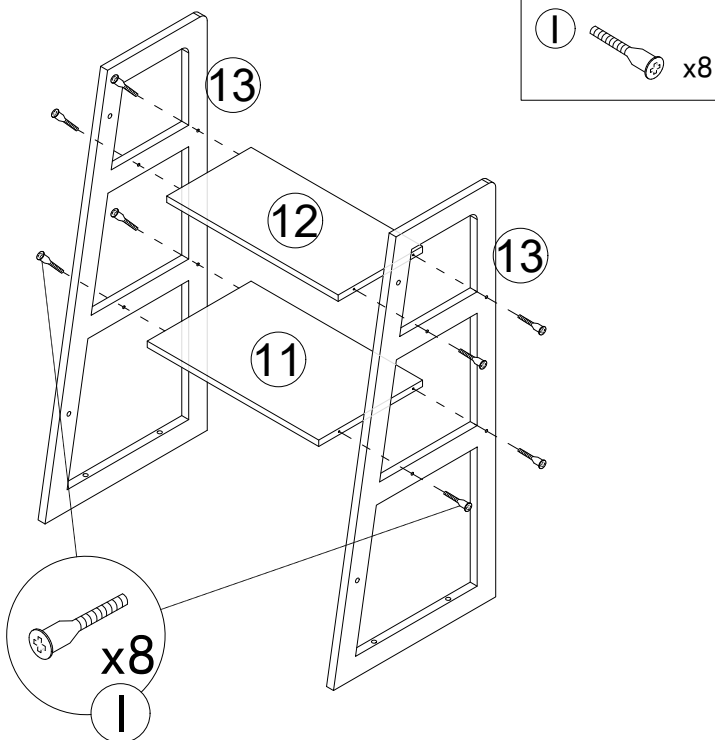

Step 19

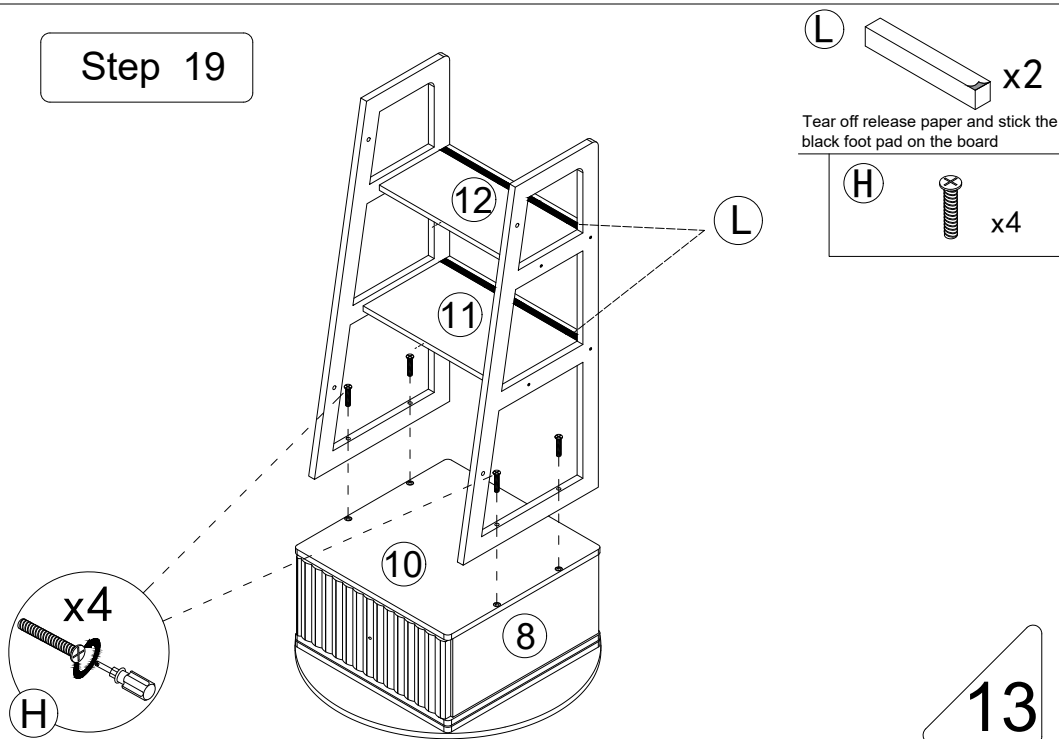

Step 20

G



x4

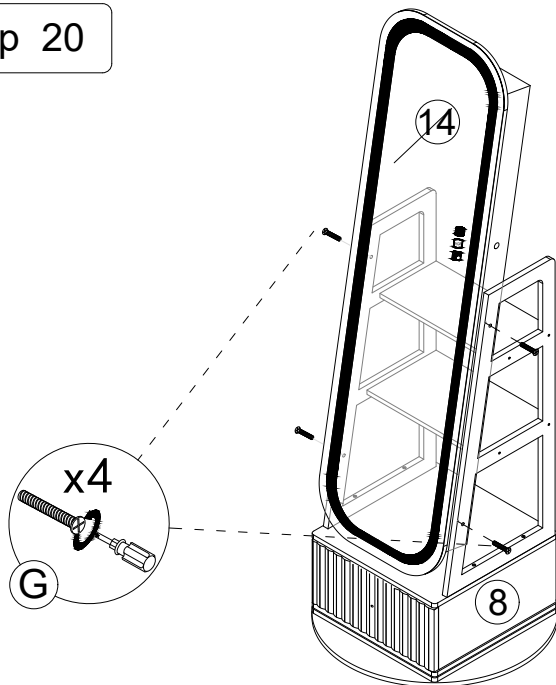

Step 21

F



x4



x2

J



x1



x1



x1

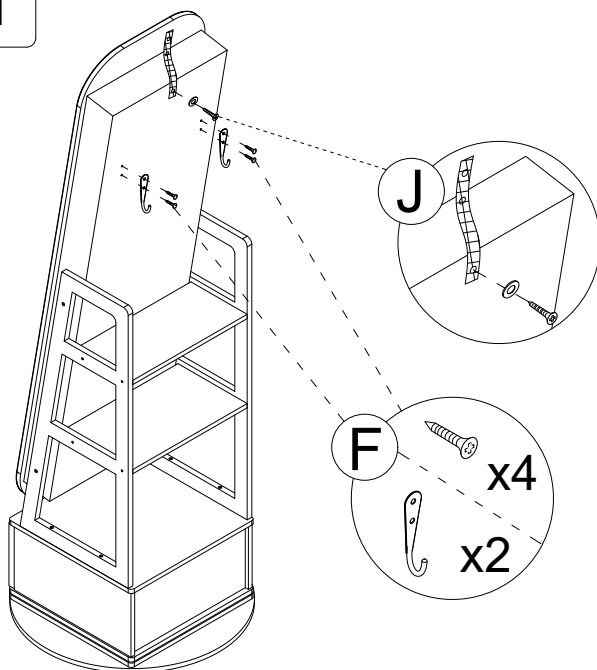

Step 22

Wall Mount

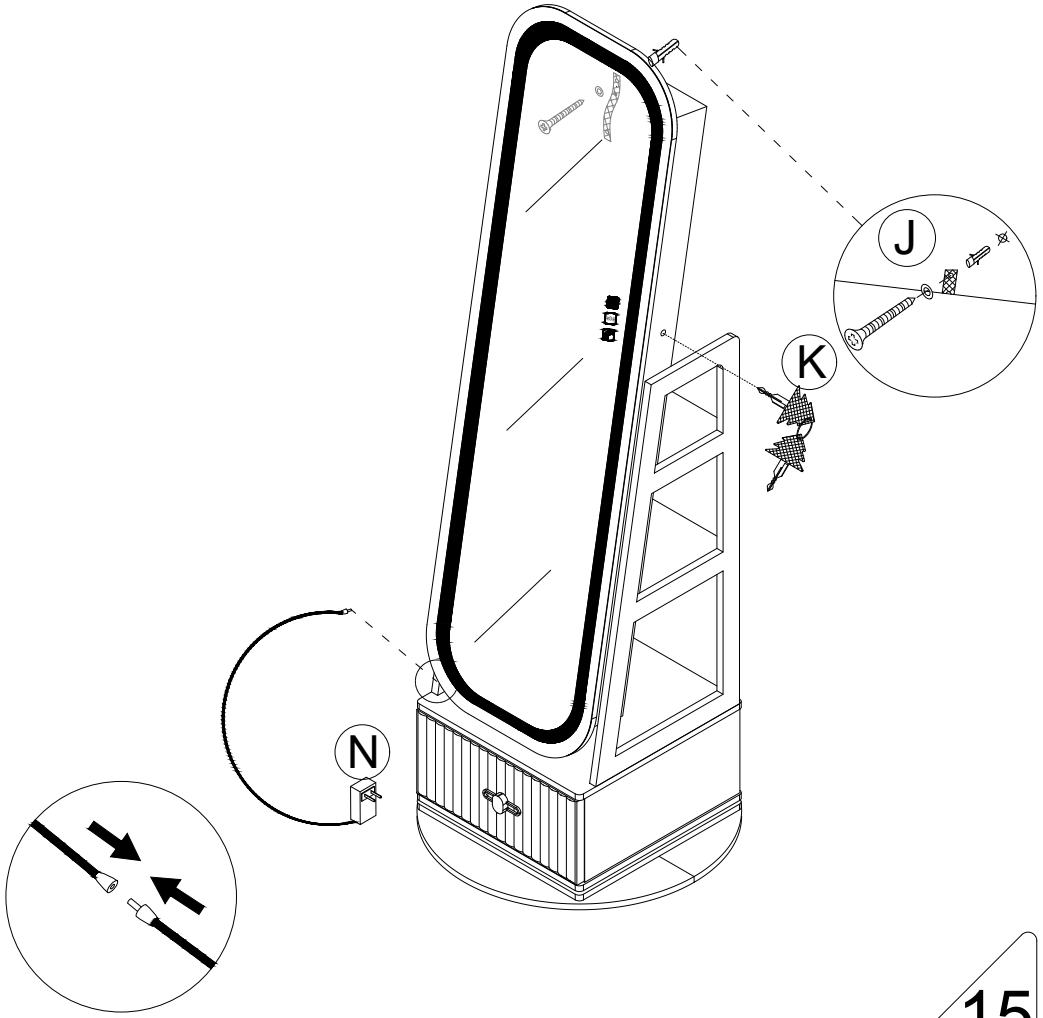
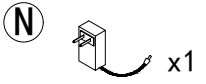
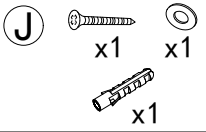
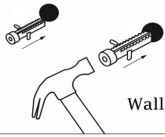
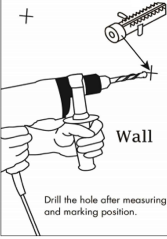

Touch button description



1. ON/OFF

2.Static Light Mode
(Long press to adjust brightness)

3.Dynamic Mode
(Long press to adjust speed)

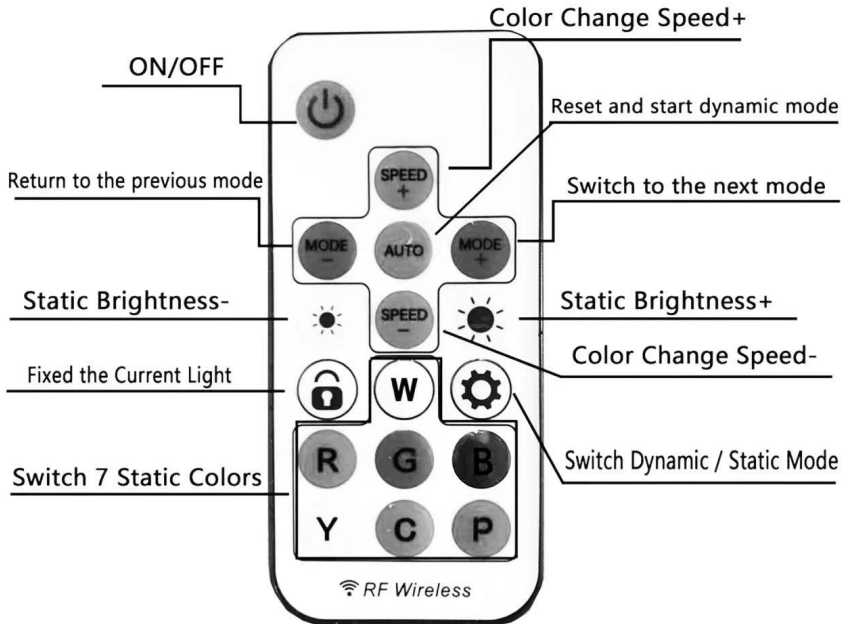

LED Lights Controller-use instructions

Remote Battery: CR205 3V

How to use the controller?

1. After inserting the DC power adapter, you can use the remote control to control the lamp. Press the "on/Off" button to turn on the light and enter the static light mode.

Long press the "on/Off" button to turn off the light.

2. There are 7 RGB Dynamic Modes. You can press the "MODE+/-" key to choose dynamic colors that you preferred and press the "Speed+/-" key to adjust color change speed.

3. There are 7 static colors: White / Red / Green/ Blue / yellow / ice blue/ pink light. You can press the "Brightness +/-" key to adjust the brightness.

4. You can press the "lock" key to fix the color you like. When you press the "Switch Dynamic /Static Mode" key, the light will change between dynamic mode and static mode.