

Assembly Instructions

Caution: You must read this before you proceed

Care & Maintenance



• Not for commercial use. For residential use only.



• Do not put hot items directly on furniture surface.



• Do not clean furniture with harsh cleansers or polish.



• To obtain the longest lifespan of your outdoor product minimizing exposure to direct sunlight is recommended.



• Children should not climb or jump on the furniture.



• Do not write on furniture without a padded barrier to protect the surface.



• To obtain the longest lifespan of your outdoor products, avoid extended and lengthy exposure to rain, snow, and direct sunshine. Whenever possible cover the product and /or place under patio or awnings.



• Stains may be removed with mild soap solution and damp cloth.



• Dust and pick-up spills using a clean, non-colored, lint-free cloth.

Please look in the Leg Panel for Hardware packs and Legs

BENCH

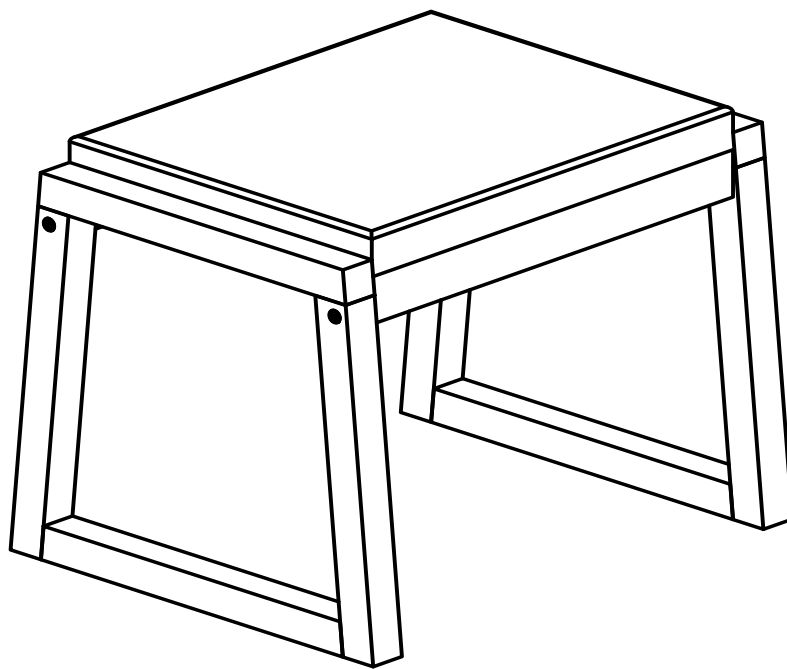

Caution: This Bench is NOT a TOY.



Keep your child / children at bay during the assembly process.

Whenever lifting or moving the Bench and to prevent damage to the Bench, two adults may be needed to execute these actions.

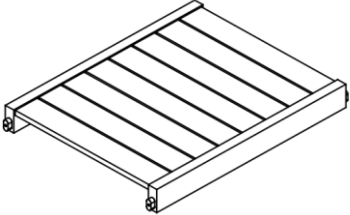
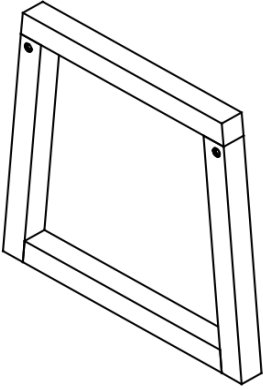
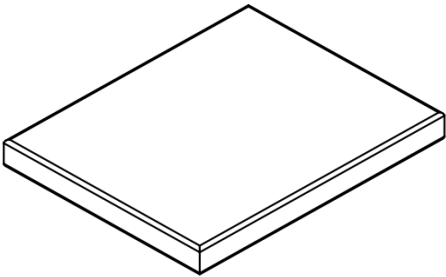
Parts List:

Label	Picture	Description	QTY
A		Seat Panel	1
B		Leg Panel	2
C		Seat Cushion	1

Hardware:

Label	Picture	Description	QTY
①		Screw (M6*70mm)	5
②		Allen Wrench	2

Assembly Preparation:

Before Beginning Assembly:

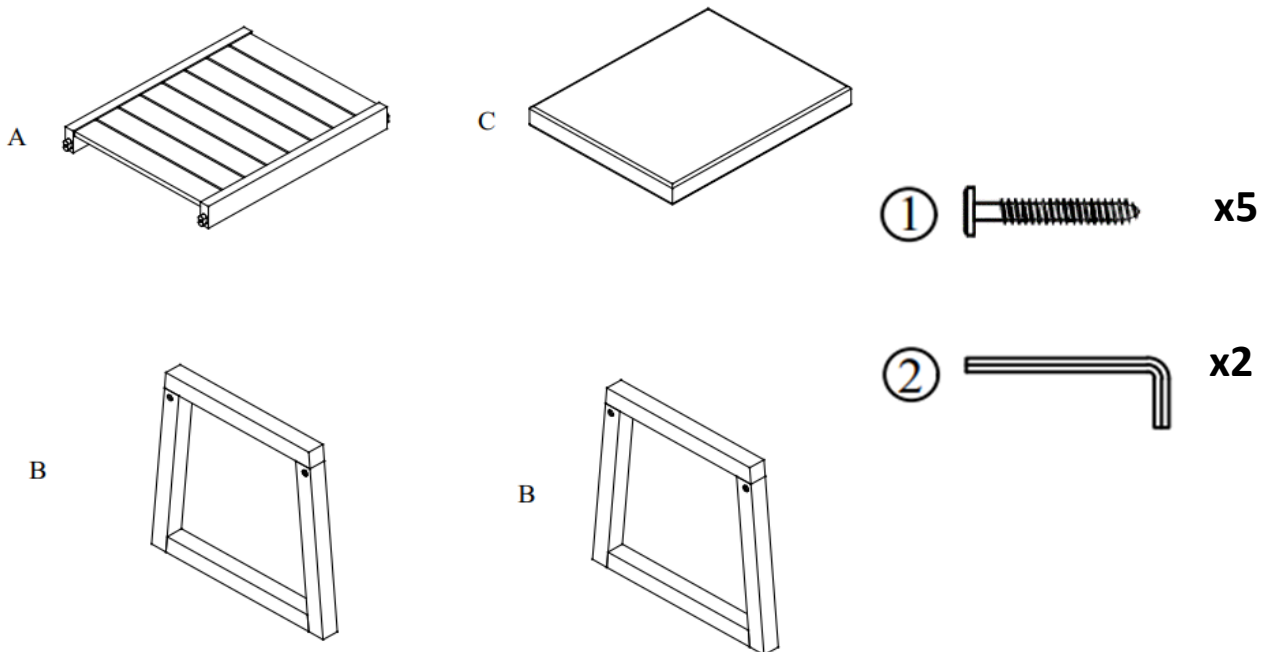

- Read instructions, cover to cover-



- Have 2 adults on hand for assembly-



- Do not assemble on flooring or carpet-



- Assemble on a clean non-marring surface (packing foam)-



- Save all packaging until finished-

Assembly Steps:

Overview:

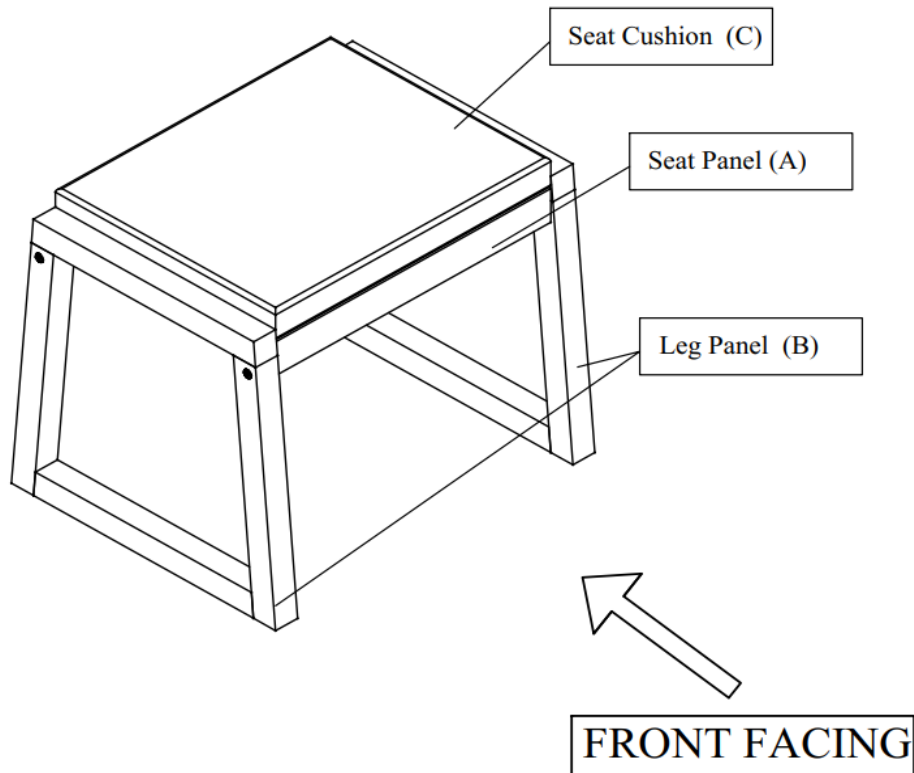

This Bench has multiple parts and may require up to 30 minutes to assemble. To give you an overview of the Bench parts, the above picture is to help you put the various parts into perspective. Please read through the instructions below to familiarise yourself with the parts and steps before assembly.

Step 1:

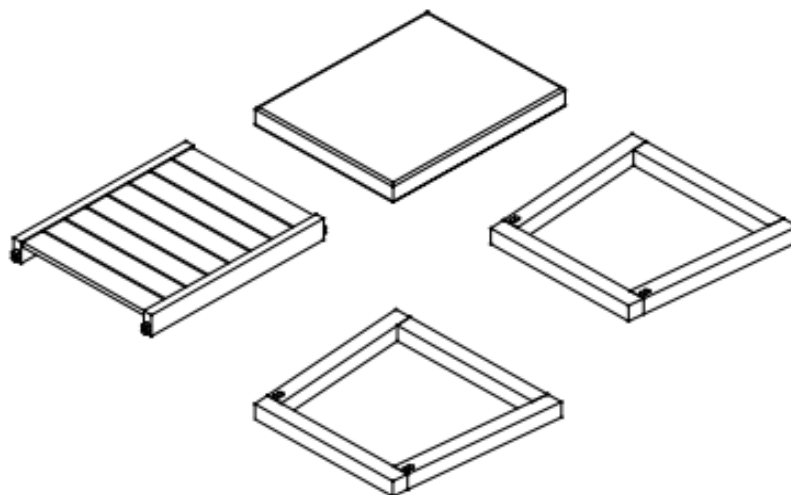

Unpack and place all parts on a clean, non-marring surface.

Step 2:

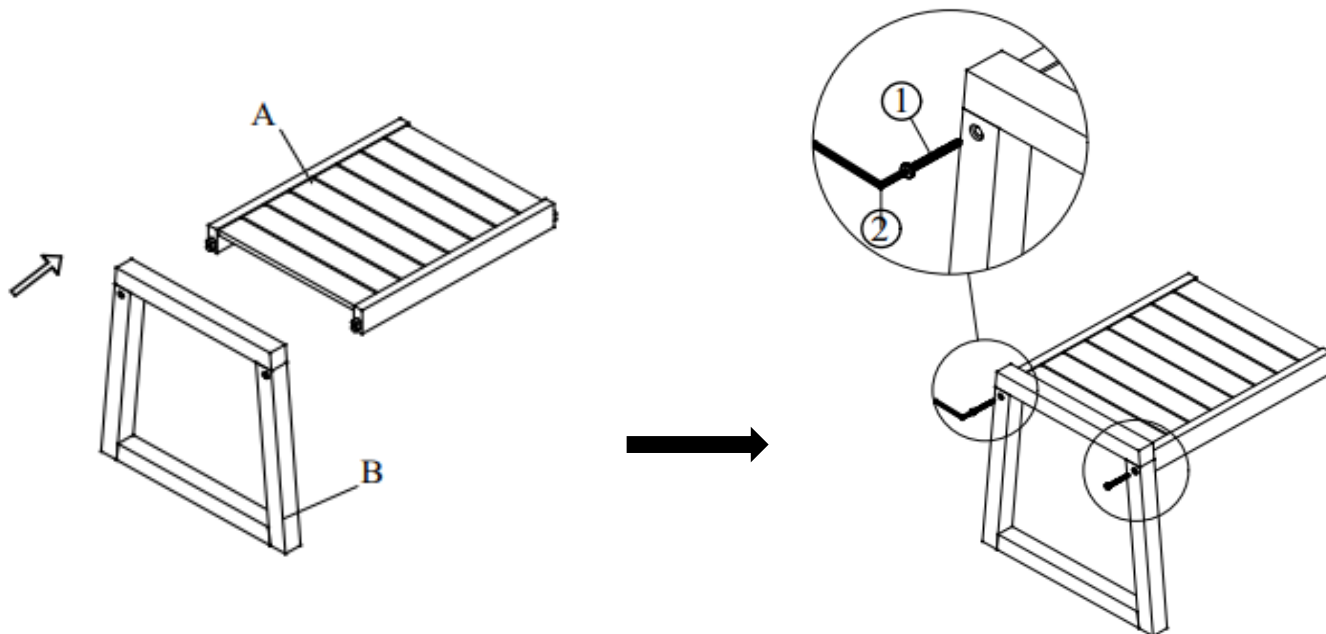

With the help of your adult partner, put the tenon of Seat Panel (A) into the mortise of the Leg Panel (B), then secure by using Screws (①) and Allen Wrench (②) as shown above.
Do not fully tighten the Screws.

Step 3:

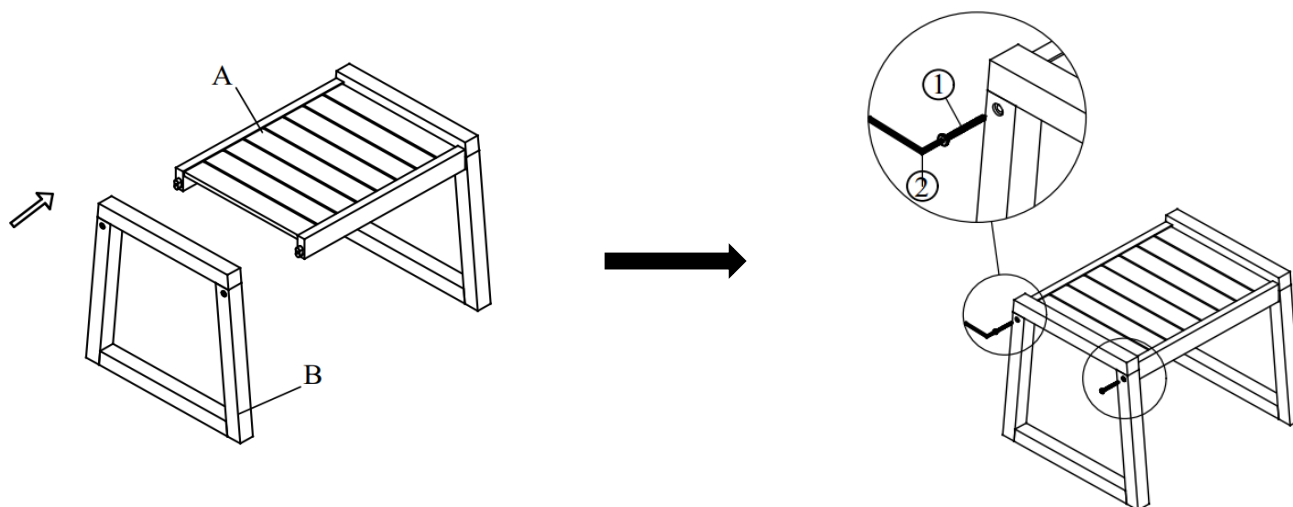

With the help of your adult partner, put the tenon of Seat Panel (A) into the mortise of the remaining Leg Panel (B), then secure by using Screws (①) and Allen Wrench (②) as shown above.
Do not fully tighten the Screws.

Step 4:

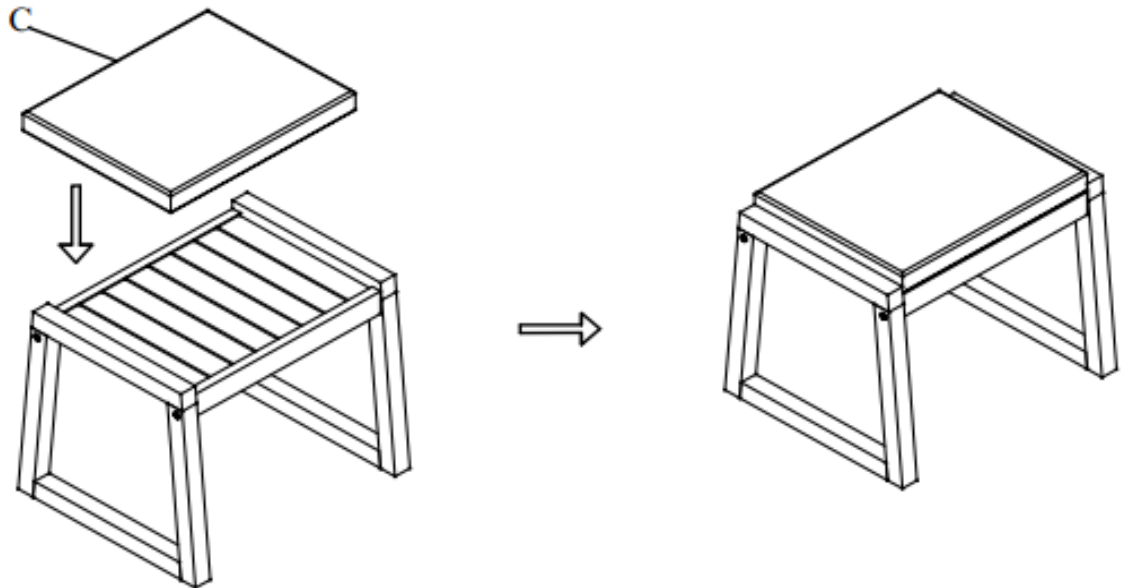

Place Seat Cushion (C) on the Bench as shown above.

Step 5:

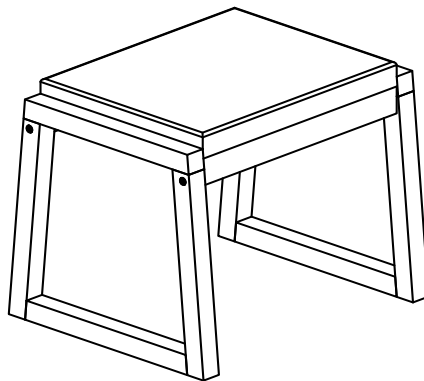

Exert pressure floorwards, onto the Bench with both your hands.

This pressure will help the Legs and Bench Top reach full alignment status.

Check for wobbles on a LEVEL surface.

If no wobbles are found proceed to tighten the Screws in a sequential manner, until evenly secured.

When tightening the Screws tighten sequentially.

Do not tighten any Screw fully and then move on towards the next one.

If there are still wobbles, loosen the Screws and excute the same above process.

Your Bench is ready for use.

This Bench can only be used on a flat, level surface.