







ASSEMBLY INSTRUCTIONS

30" & 36"

- Please unpack all parts and check against parts list on this instruction sheet before discarding the packaging.
- **Note:** We recommend at least 2 people assist in installation to avoid injury or damage to the product.

#	Part Description	Dimensions		QTY
1	Floating Vanity	762X533X610mm (30") 915x533x610mm (36")		1 pc.
2	Wooden Hanger	220x50x20mm (30" & 36")		3 pcs.
3	Plywood Panel	722X160X18mm (30") 875x160x18mm (36")		1 pc.

RTA Hardware			
#	Drawing	Item	QTY
A		Plastic Anchor $\varnothing 14 \times 47 \text{mm}$	15 pcs.
B		Long Screws $\varnothing 8 \times 50 \text{mm}$	15 pcs.
C		Short Screws $\varnothing 8 \times 35 \text{mm}$	14 pcs.

Tools

- Screwdriver, Drill, Hammer ... (not included)

Assembly Instructions

Step 1:

- Hold the plywood panel (3) against the wall and align the screw holes with your stud locations.
- Use a writing utensil to mark the locations.
- See Figure 1 for recommended mounting height.
- Drill at marked locations and tap plastic anchor (A) into hole until flush.
- Use long screws (B) and drive them through the plywood panel and into each anchor to secure.

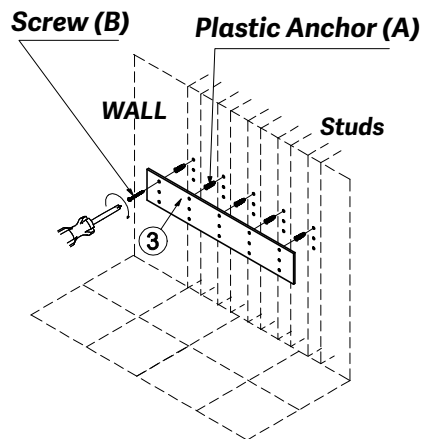
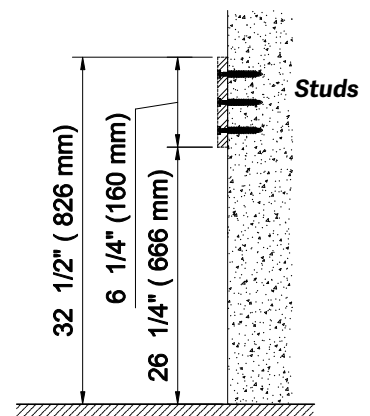

Figure 1



Step 2:

- Use short screws (C) to attach the wooden hanger (2) to the plywood panel (3).
- Use Figure 2 as reference for mounting height.

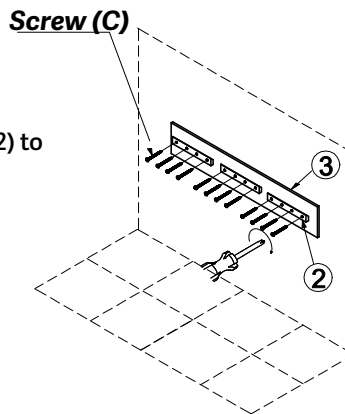
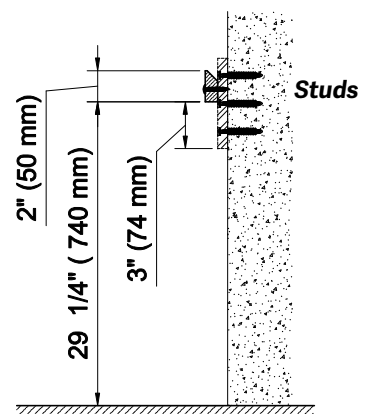
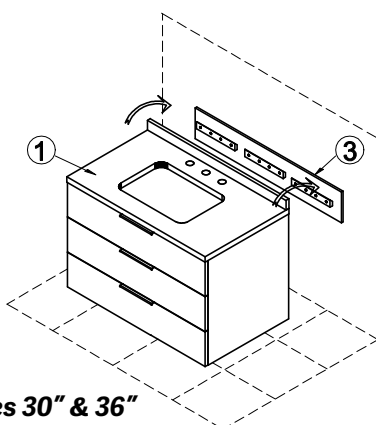

Figure 2



Step 3:

- Hang the vanity (1) on the wooden hanger (2).
- Use Figure 3 as reference for recommended final mounted height.



Vanities 30" & 36"

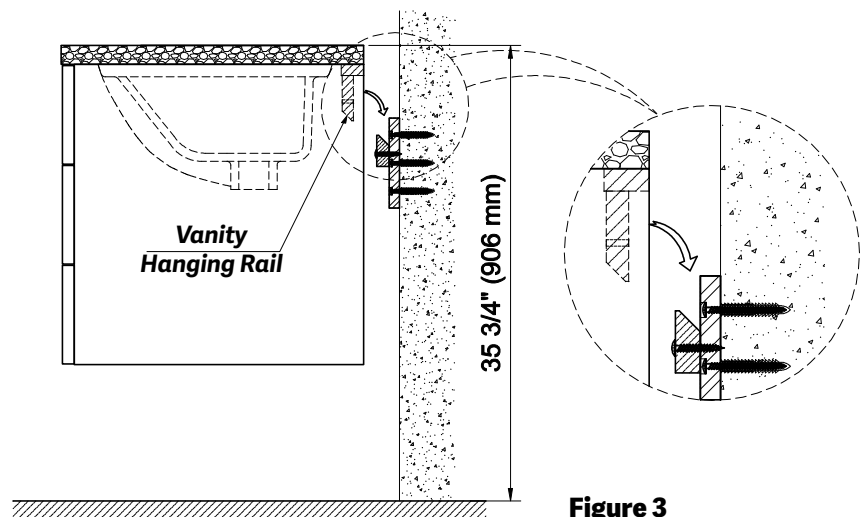

Figure 3

ASSEMBLY INSTRUCTIONS

30" & 36"

Step 4:

- Remove the middle drawers by pulling on the drawer, and pushing the locking device at the same time. See Figure 4.

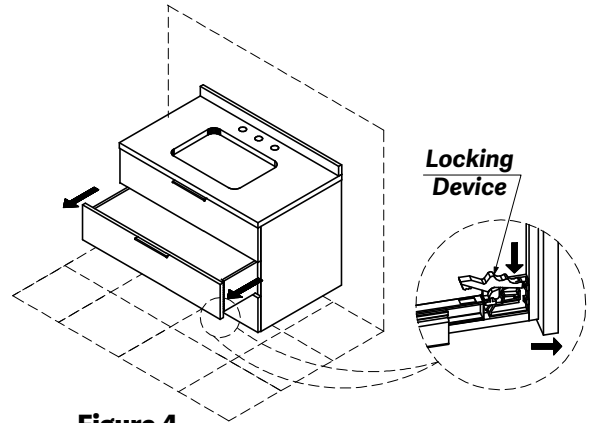

Figure 4

Step 5:

- Drive short screws (C) through the two holes located on the Vanity Hanging Rail. See Figure 5.

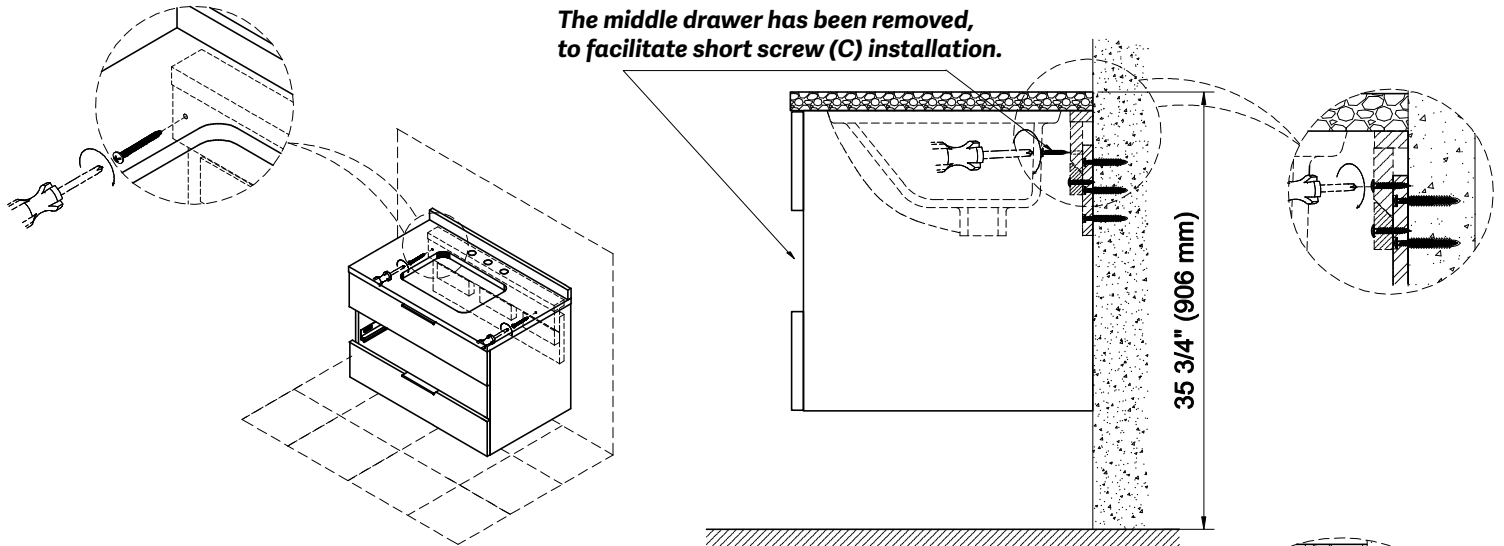

Figure 5

Step 6:

- Fully extend the slide rail out. See Figure 6.
- Place the drawer onto the slide rails. See Figure 7.
- To secure the drawer, close until a series of clicks are heard. See Figure 8.

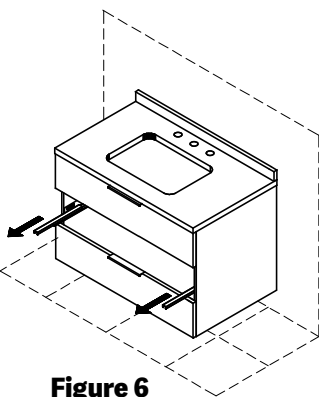

Figure 6

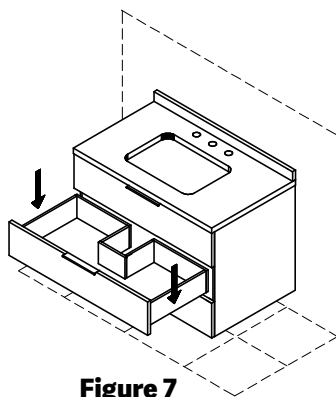

Figure 7

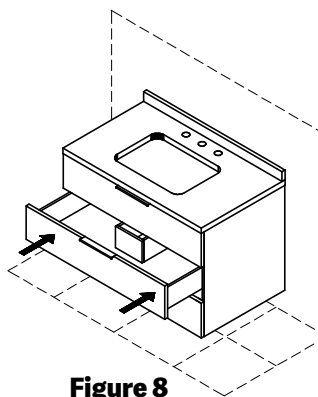

Figure 8

