













CARE AND MAINTENANCE

Wipe clean with a soft, dry cloth. Test the cleaning method on a hidden area before using them over the entire area.

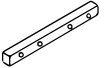
NOTICE

- * Please make sure that you have all parts indicated before you begin assembly of this item.
- * This item should be assembled on a soft surface to prevent scratching the finished product during assembly.
- * This item may require periodic tightening.
- * Do not tighten bolts until completely assembled.

Part List and Hardware List

PIECE	DESCRIPTION	PICTURE	QUANTITY
A	HEADBOARD		1X
B	FOOTBOARD		1X
C	SUPPORT LEGS OF SLATS		8X
D	SLAT		4X
E	L-RAIL		2X
F	R-RAIL		2X
G	WOOD BAR		2X
H	PLASTIC LEG		8X
H1	BOLT 5/16"*2-1/2"		16X
H2	ALLEN KEY 5mm		1X
H3	SCREW Ø8*40mm		8X
H4	SCREW Ø8*15mm		8X
H5	METAL PLATE 50*33*3mm		2X

Product Dimensions: 91.5"W*66.5"Dx34"H

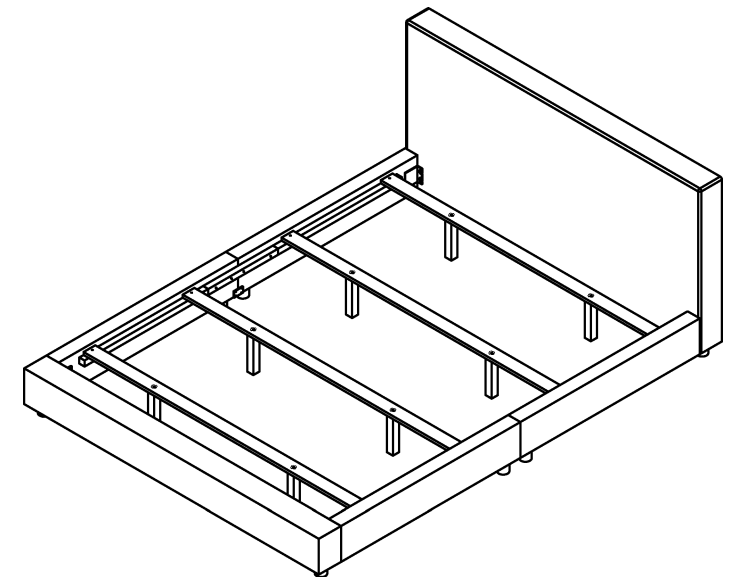

Weight capacity : 550 lbs
WARNING : DO NOT STAND ON THE BED

PREPARATION

Before beginning assembly of product, make sure all parts are present. Compare parts with package contents list and hardware contents list. If any part is missing or damaged, do not attempt to assemble the product.

Estimated Assembly Time: 30 minutes.

Tools Required for Assembly (included): Allen Key (included) and Philips head screwdriver (not included)

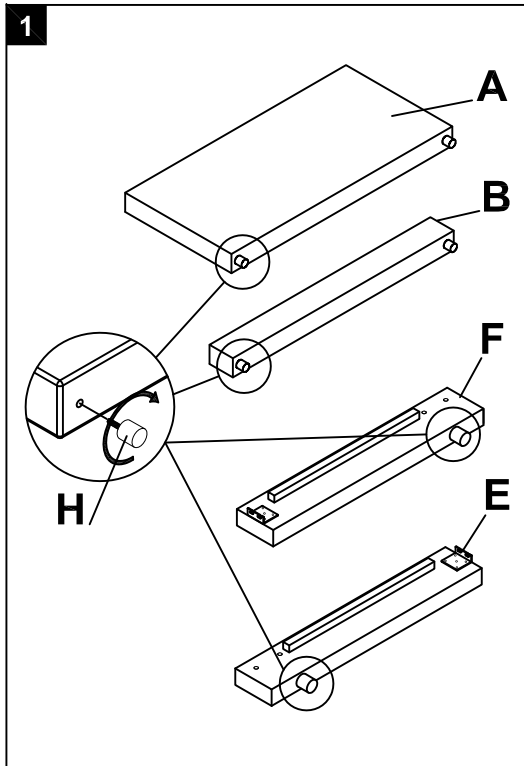

Step 1

Turn 4*Plastic leg (H) by clockwise to locking into the screw hole in the bottom of Headboard (A) and Footboard (B) respectively.
Turn 4*Plastic leg (H) by clockwise to locking into the screw hole in the bottom of 2*L-Rails (E) and 2*R-Rails (F) respectively.
As picture.

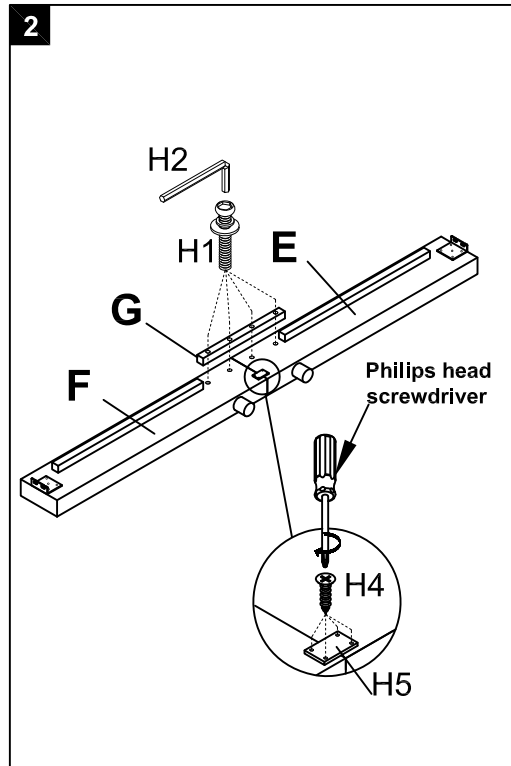

Step 2

Attach wood bar (G) to the 2 Rails (E & F), Using Allen key (H2) to locking by 4*bolts (H1), then lock the both side rails (E & F) (front & rear of rail) tight and alignment with metal plate (H5) and use Philips head screwdriver (tool is not included) to lock 4*screws (H4). Repeat above procedure for assembly to the other side rail.

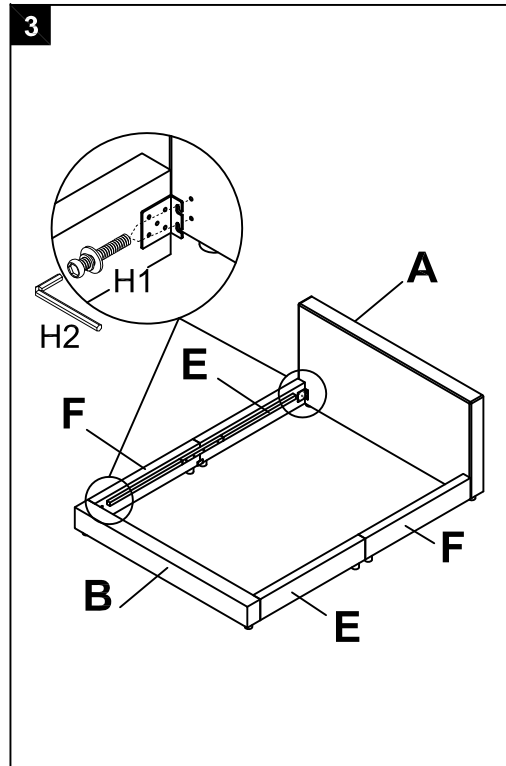

Step 3

Attach the end of assembled 2*side rails to the Headboard (A) and Footboard (B), Using Allen key (H2) to lock with 8*bolt (H1), as picture.

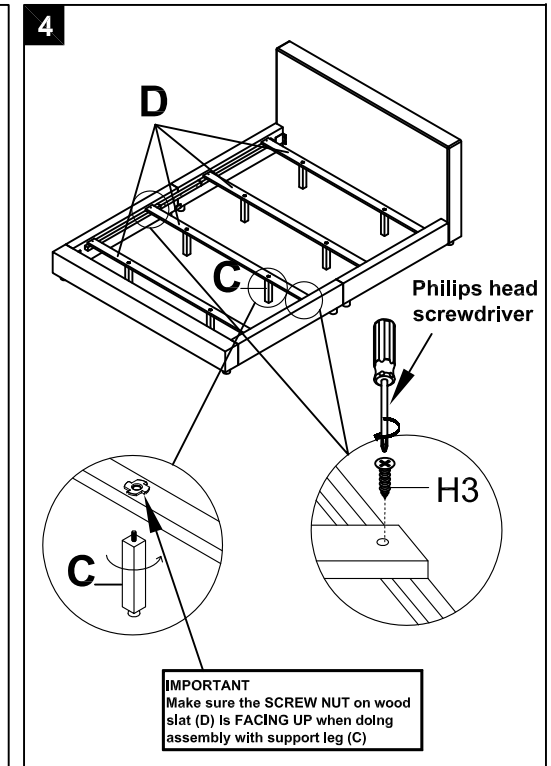

Step 4

Turn 2*Support Legs (C) into each Slat (D); Repeat the same procedure to rest 3 slats. as picture.
Lock slats (D) tight with wooden bar (Attached on the inside of both side rails), by using Philips head screwdriver (tool is not included) to lock 8*screws (H3), as picture.
Assembly is completed.