

INSTRUCTION

ANWEISUNG

取扱説明書

INSTRUCTION

사용설명서



***Two people for assembly**
***Installieren zwei Personen zusammen**
***2人作業が必要です**

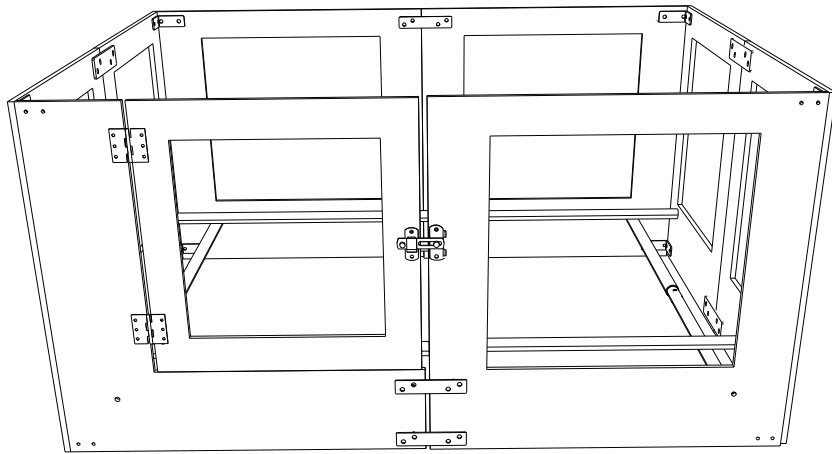

A×1

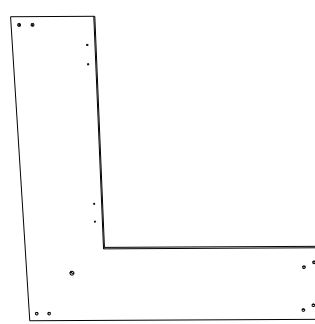

B×1

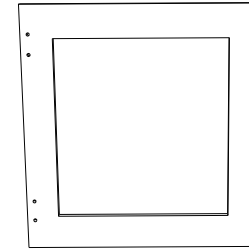

C×1

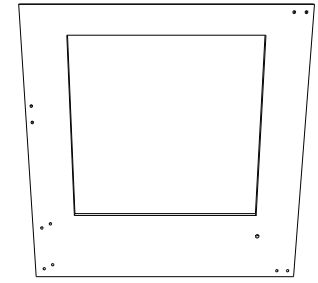

D×1

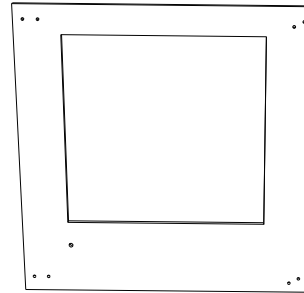

E×1

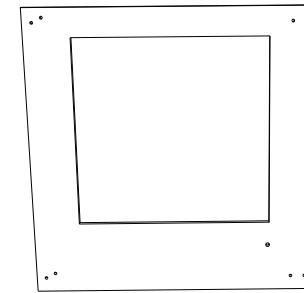

F×2

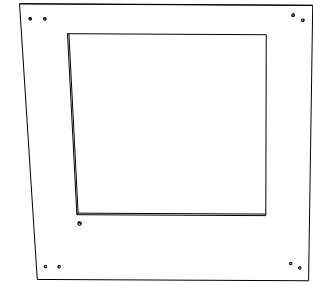

G×2

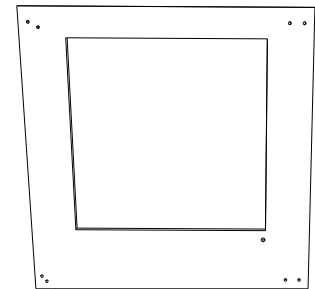

U×1

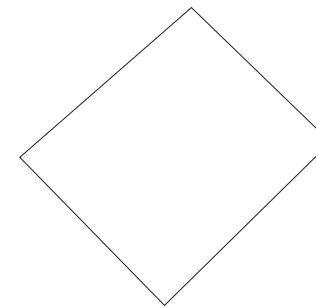

I×4



H×4

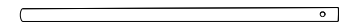

FR



ÉTUI



C&E Connection
E-Commerce (DE) GmbH
 Zum Linnegraben 20, 65933,
 Frankfurt am Main, Germany
 info@ce-connection.de



Company: YH Consulting Limited
 Address: C/O YH Consulting Limited Office 147,
 Centurion House, London Road,
 Staines-upon-Thames, Surrey, TW18 4AX



FR

Ce meuble se recycle,
 s'il n'est plus utilisable
 déposez-le en déchèterie.
 Notice à trier.
 Pour en savoir plus:
 www.quefairedemesdechets.fr

J×2

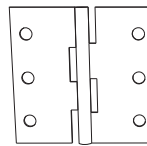

K×8

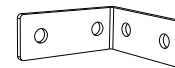

L×16

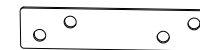

M×1



N×1

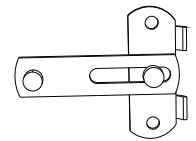

O×1



P×18



3×10

Q×32



M5×15mm

R×32



M5×18mm

S×8



M6×25mm

T×64



W×1



V×1



1、Using self-tapping screws on the part J and part M, needs to twist them in with Phillips screwdriver.
(Pay attention to the hole positions that distinguish the front and back side of the panels)

1

1、Verwenden Sie selbstschneidende Schrauben an den Teilen J und M und drehen Sie sie mit einem Phillips-Schraubendreher ein.

1、部品Jと部品Mは、タッピングネジで留めるので、ねじ回してねじ込んでください。(※取付位置は浅い「跡」で標記されています)

1、Les pièces J et M utilisent des vis autotaraudeuses. Vous devez d'abord utiliser un tournevis cruciforme pour les visser (en premier). Faites attention à la position du trou pour distinguer l'avant et l'arrière de la carte.

1、부품 J와 부품 M은 탭핑 나사로 고정시켜 나사돌리기로 비틀어 주십시오.(※설치 위치는 얇은 '자국'으로 표시되어 있습니다)

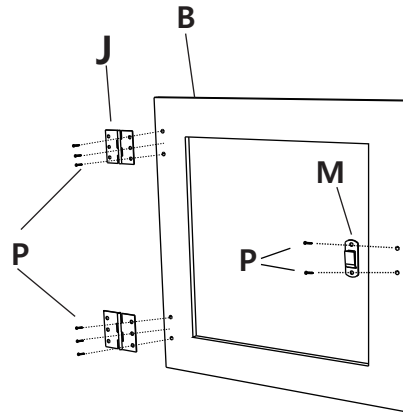

2

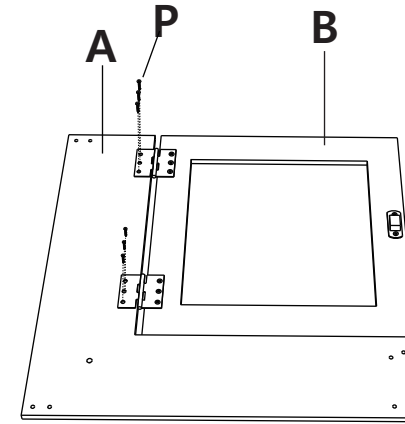

2、Pay attention to the hole positions that distinguish the front and back side of the panels

3

2、Beachten Sie bitte die Lochpositionen, die die Vorder- und Rückseite der Paneele unterscheiden.

2、部品の取付位置は浅い「跡」で標記されています

2、Faites attention à la position du trou pour distinguer l'avant et l'arrière de la planche

2、부품의 설치 위치는 얇은 '자국'으로 표시되어 있습니다

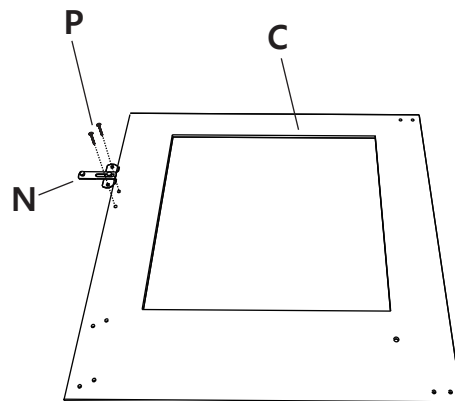

4

3、Standing the assembled part up to fix part O on the rear after installing the part N

3、Stellen Sie das montierte Teil auf und befestigen Sie Teil O hinten, nachdem Teil N installiert wurde.

3、部品Nを取り付けた後、背面に部品Oを取り付けます

3、Après avoir installé la pièce N, levez-vous et installez la pièce O à l'arrière

3、부품 N을 장착한 후 후면에 부품 O를 부착합니다.

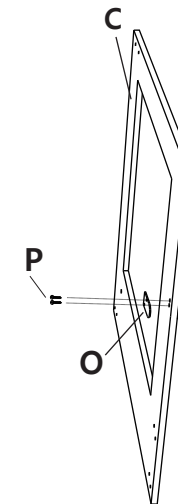

5

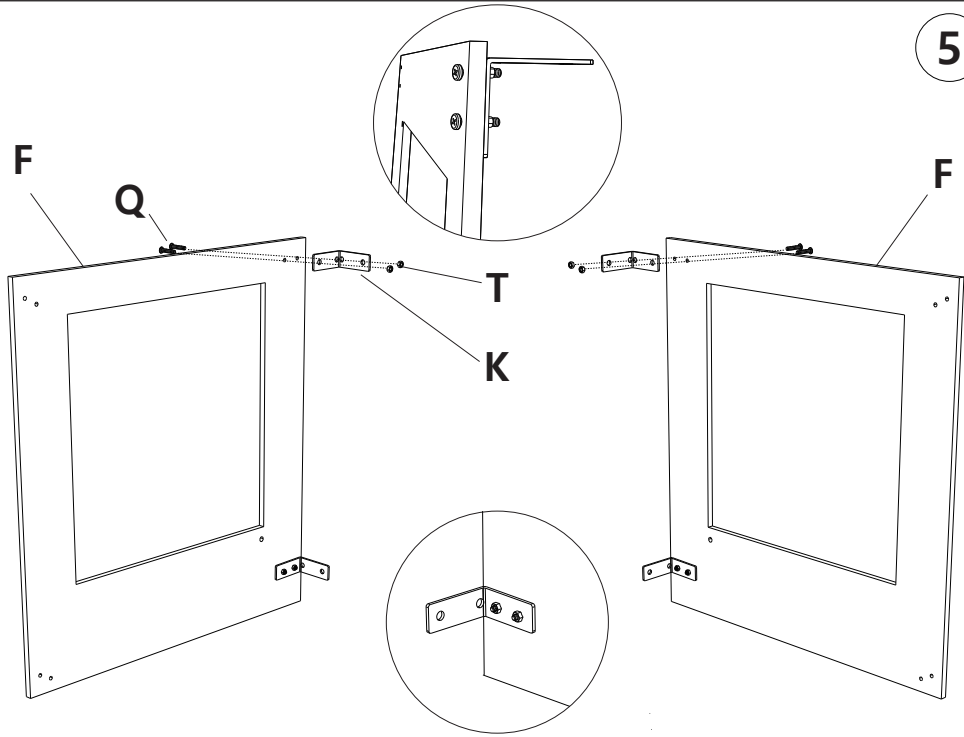

6

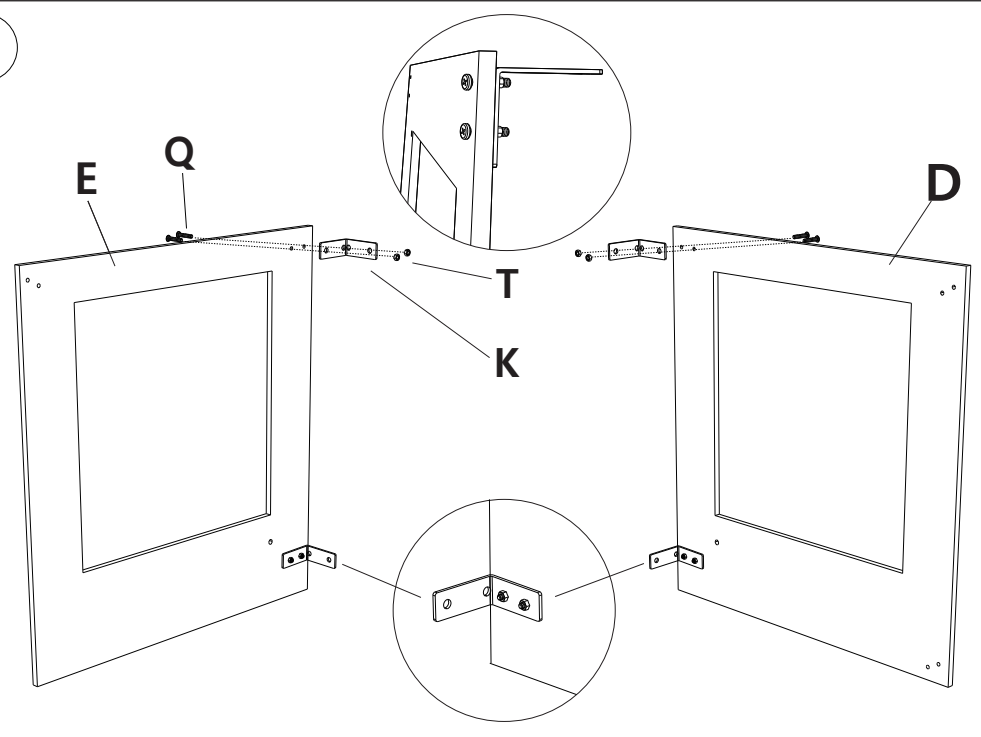

7

- 4, Twist all screws away from the front panel and secure them to the back panel with nuts
- 4, Alle Kreuzschlitzschrauben befinden sich auf der Vorderseite des Holzbretts, die Muttern sind auf der Rückseite.
- 4, すべてのネジもパネルの正面からねじ込んで、ナットでパネルの背面に固定してください。
- 4, Toutes les vis cruciformes sont destinées à l'avant de la planche et les écrous sont destinés à l'arrière.
- 4, 모든 나사도 패널 정면에서 비틀어 너트로 패널 후면에 고정하십시오.

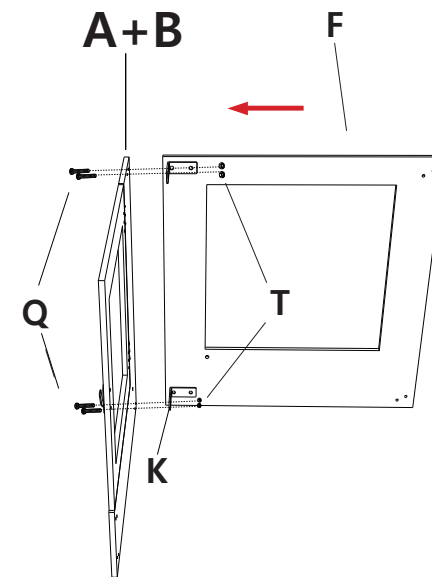
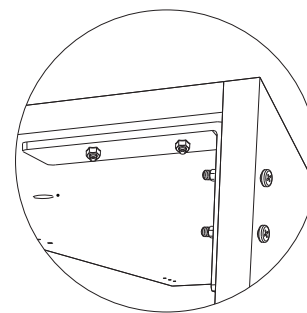
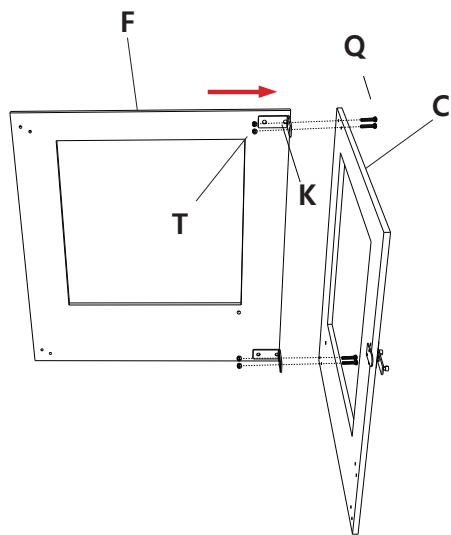

8

A+B+F

C+F

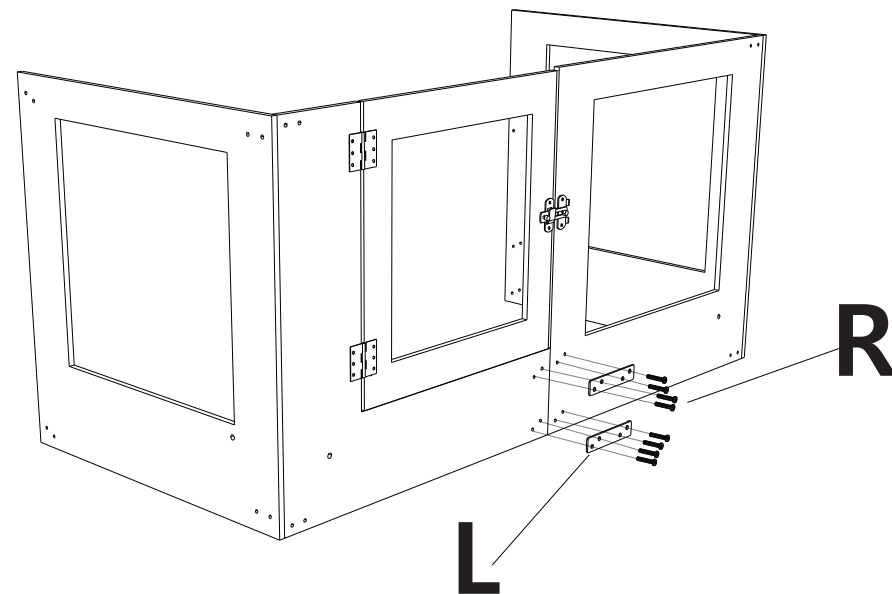
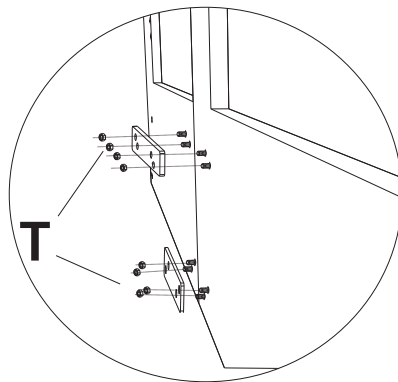
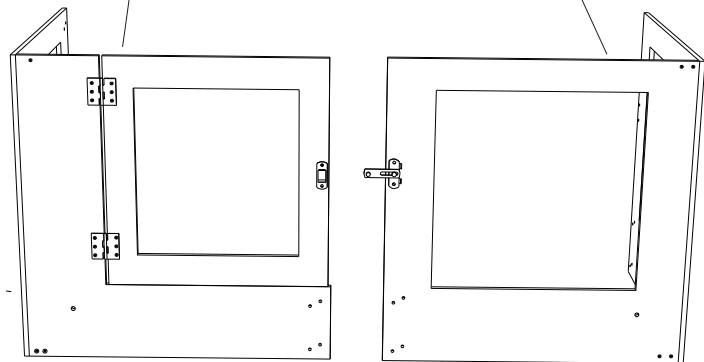

9

5、Connect the panels with part L, then fix them with screws R and nuts T

5、Verbinden Sie bitte die Paneele mit Teil L und befestigen Sie sie dann mit Schrauben R und Muttern T.

5、説明図のように、2つの部品Lと長ねじRとナットTでパネル同士を連結します

5、Serrez le raccord en L avec l'avant et l'arrière face à face et utilisez la longue vis R (étapes 8 et 10).

5、설명서와 같이 2개의 부품 L과 긴 나사 R과 너트 T로 패널끼리 연결합니다.

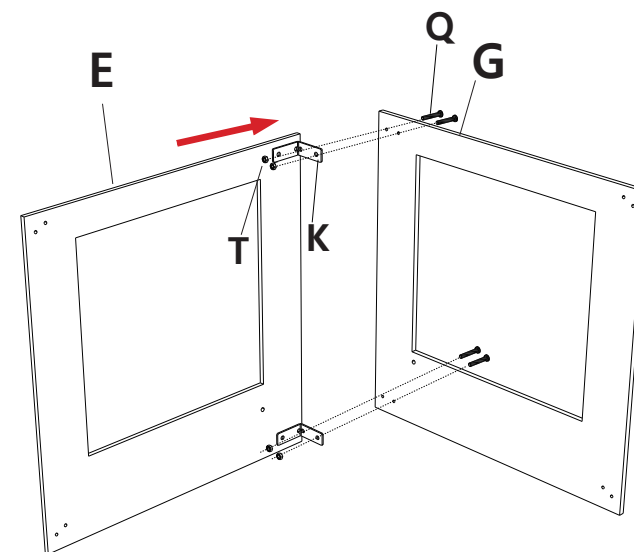
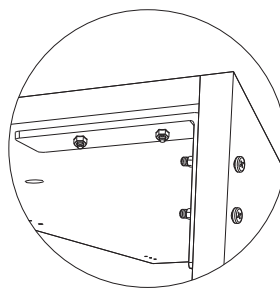
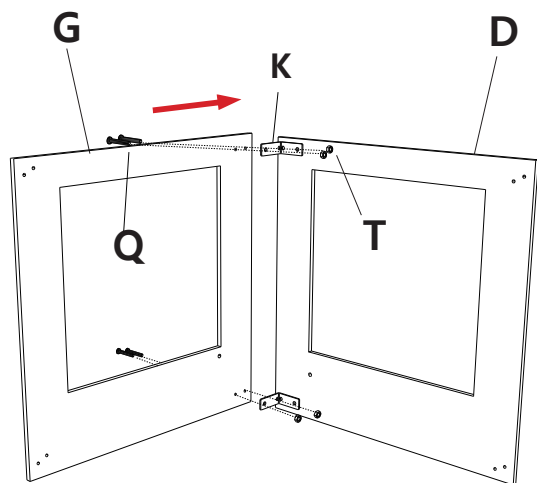

10

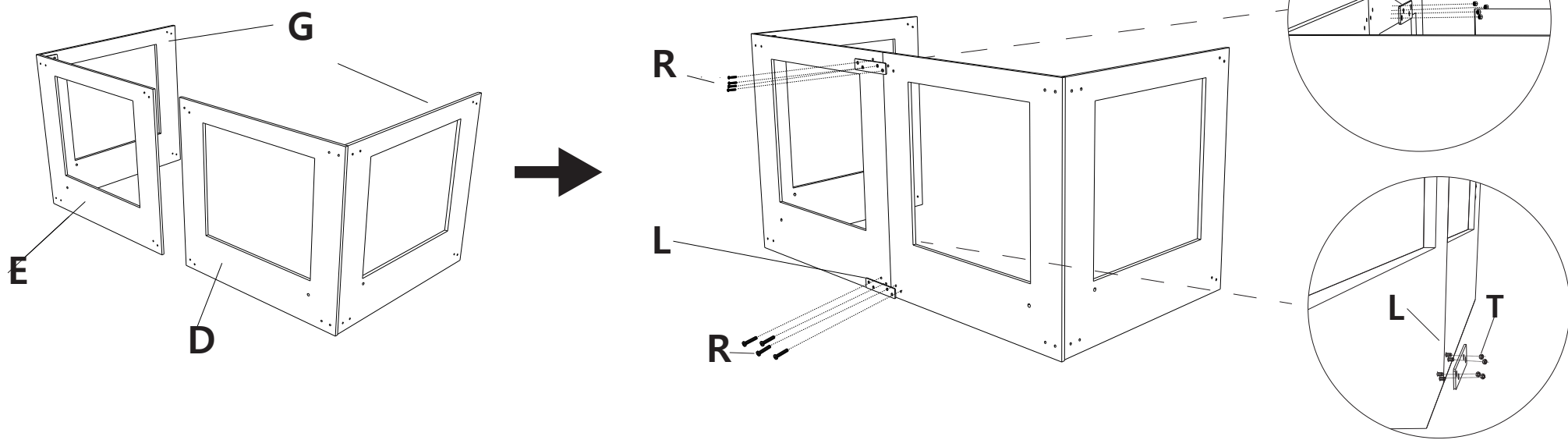

11

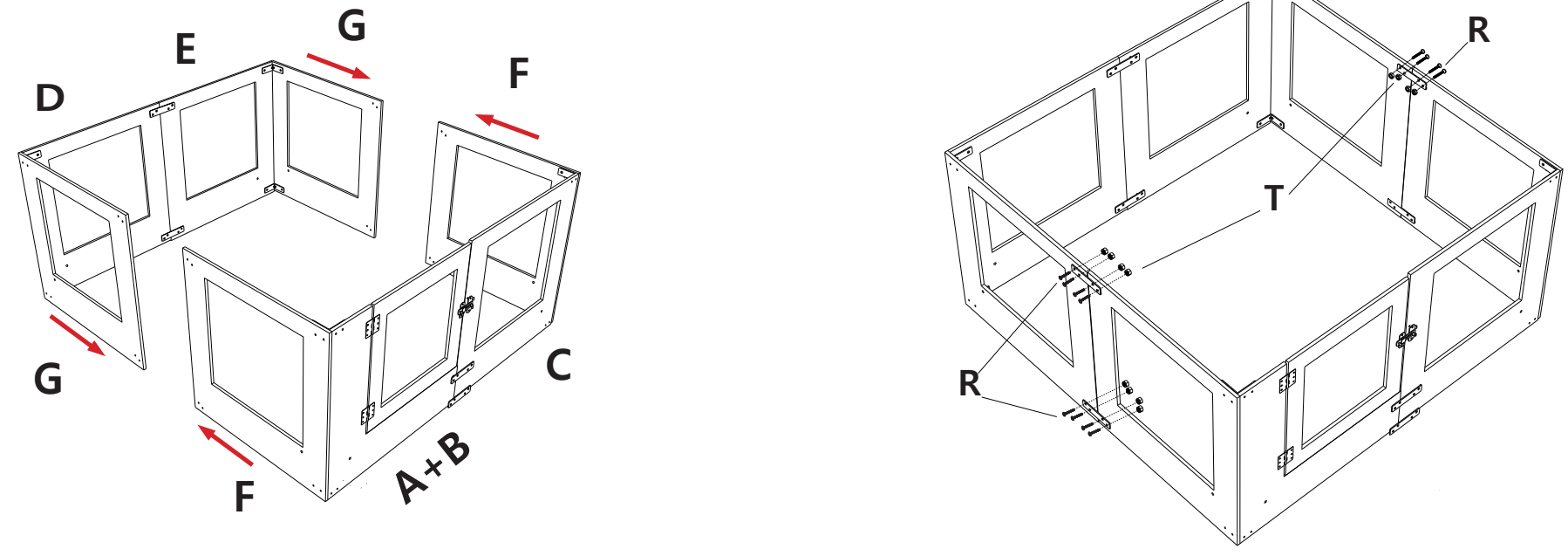

12

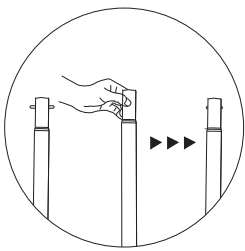

6. There is a spring buckle on the top of part I, needs to press it to connect to the part H, then fix with screws S

6. Oben auf Teil I befindet sich ein Federriegel, den Sie drücken müssen, um ihn mit Teil H zu verbinden. Fixieren Sie ihn dann mit Schrauben S.

6. パイプIとパイプHを連結した後、長ねじSでサークルの中に取り付けます

6. Il y a une boucle à ressort sur la tête de la tige de fer I, qui doit être pressée à la main et insérée dans l'autre tige H. Utilisez des vis longues en S pour visser

6. 파이프 I와 파이프 H를 연결한 후 긴 나사 S로 서클 안에 장착합니다.

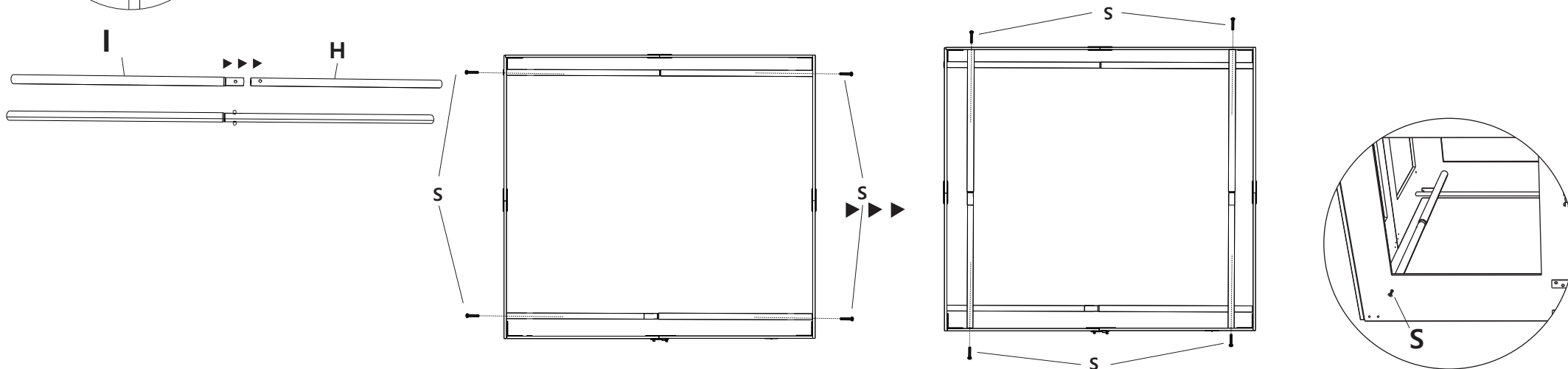

13



*Two people for assembly
*Installieren zwei Personen zusammen
*2人作業が必要です

7. Highly recommend that two people simultaneously hold the fence up and place it on the floor mat

7. Es wird dringend empfohlen, dass zwei Personen gleichzeitig den Laufstall hochhalten und auf die Bodenmatte legen.

7. 付属品のシートを展開してから、二人でサークルをシートの上に運搬してください

7. Placez le tapis à plat sur le sol. Deux personnes sont nécessaires pour soulever la clôture et la placer sur le tapis en même temps

7. 부속품 시트를 펼친 후, 둘이서 서클을 시트 위로 운반해 주십시오.

