

ASSEMBLY INSTRUCTION

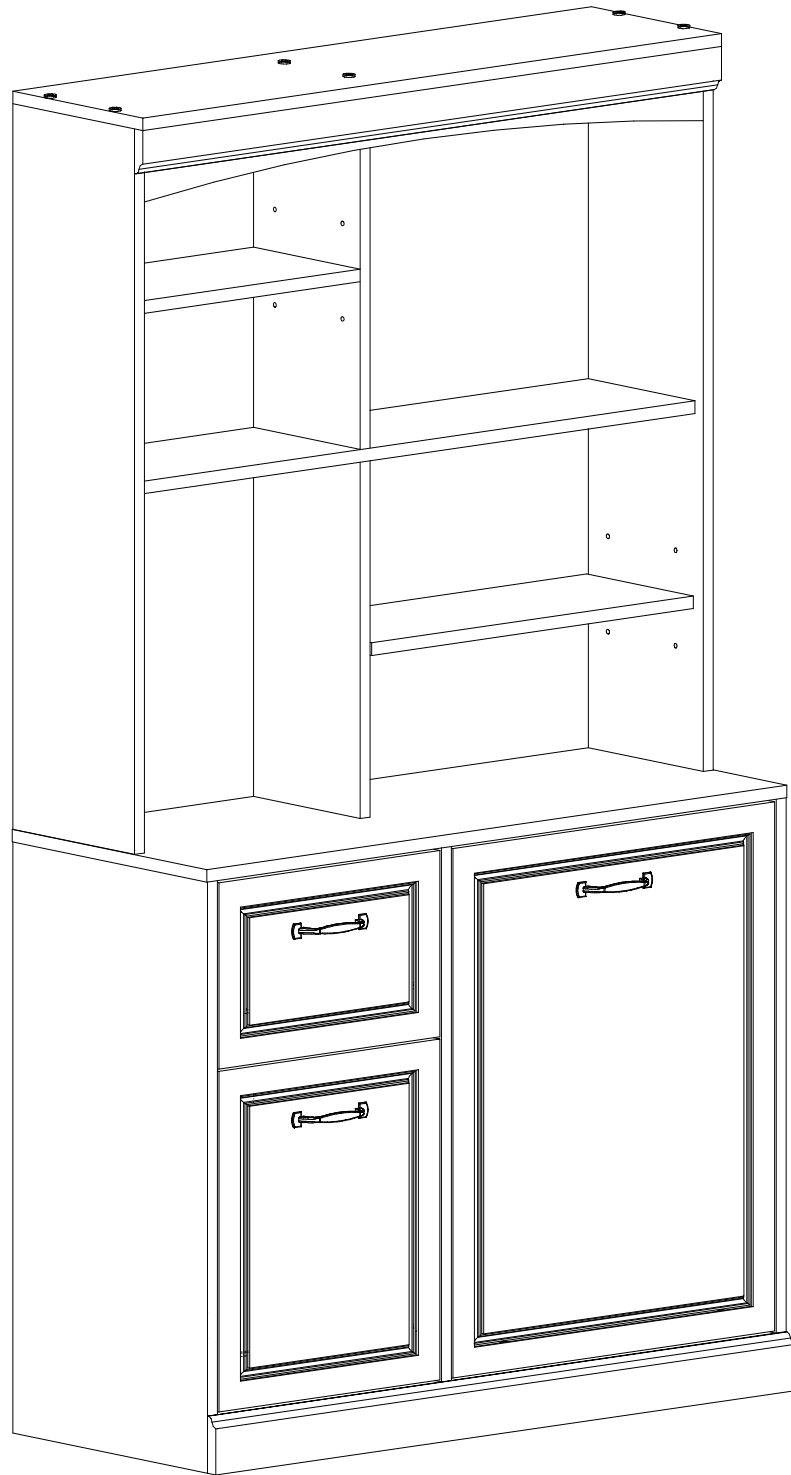

ASSEMBLY INSTRUCTION

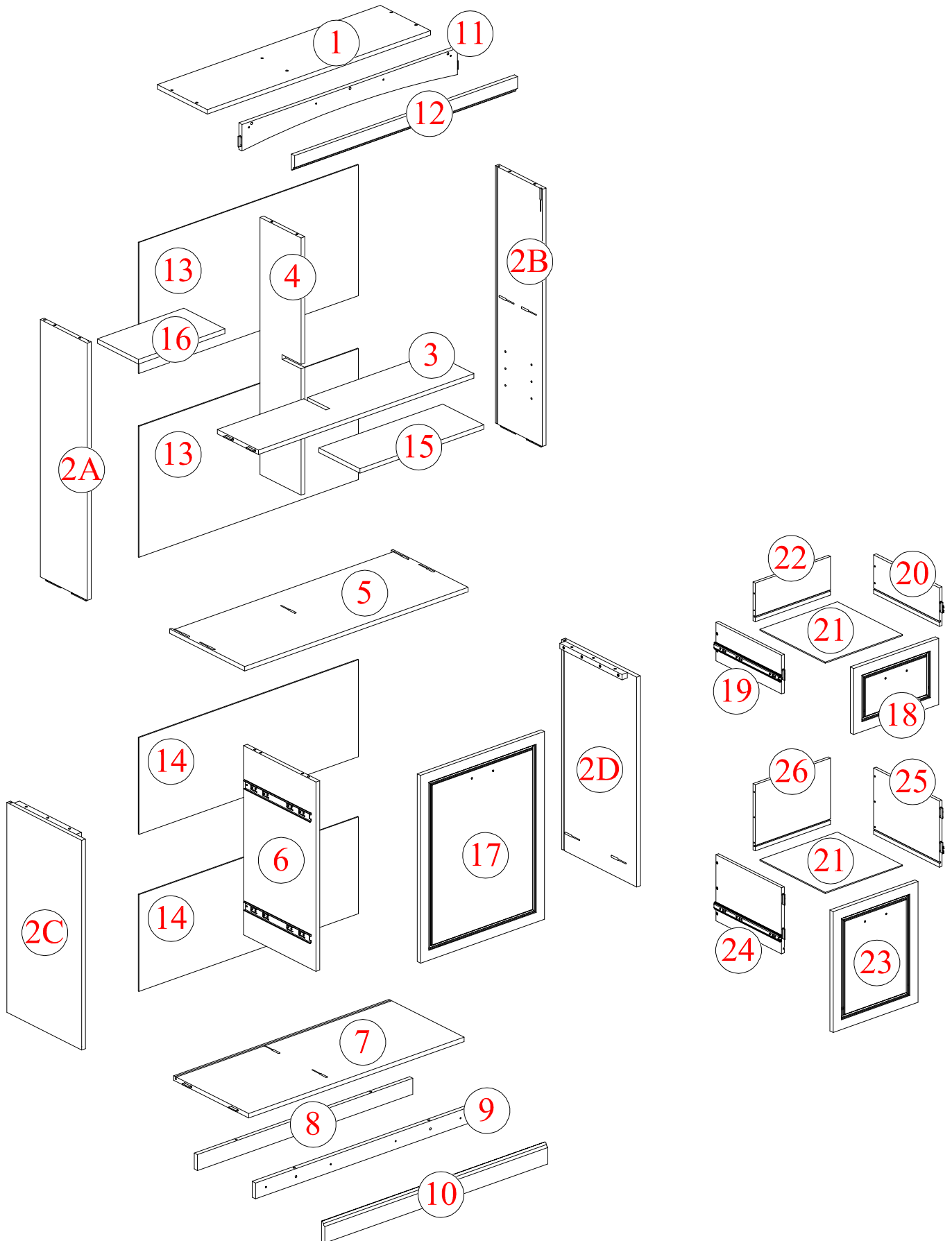

Part List

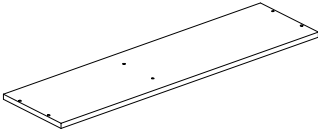
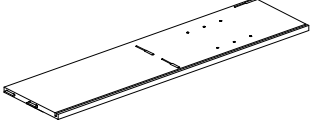
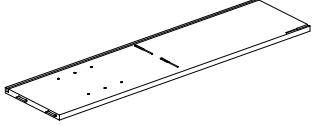
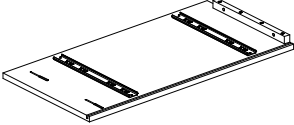
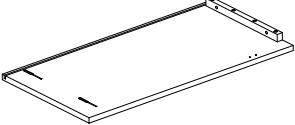
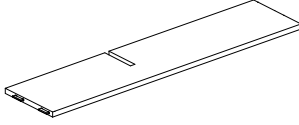
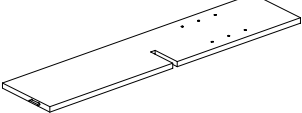
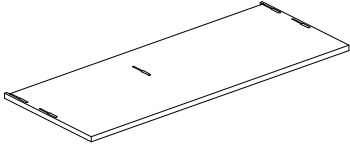
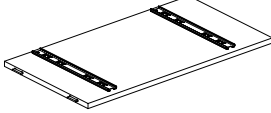
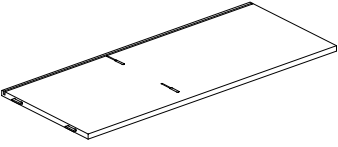
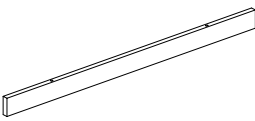
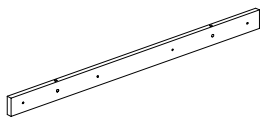
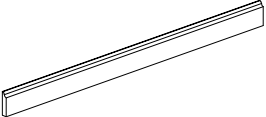
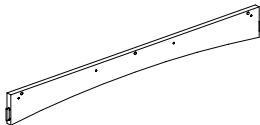
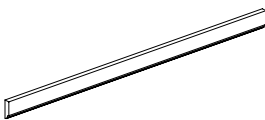
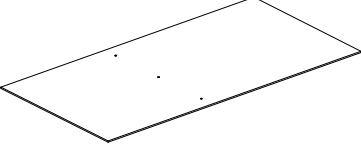
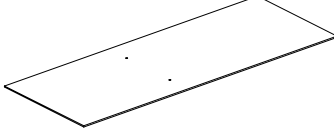
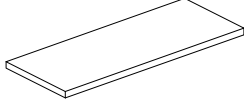
<p>1</p>  <p>Top of Cabinet - 1 pc</p>	<p>2A</p>  <p>Upper left side - 1 pc</p>	<p>2B</p>  <p>Upper right side - 1 pc</p>
<p>2C</p>  <p>Lower left side - 1 pc</p>	<p>2D</p>  <p>Lower right side - 1 pc</p>	<p>3</p>  <p>Cabinet divider - 1 pc</p>
<p>4</p>  <p>Cabinet divider - 1 pc</p>	<p>5</p>  <p>Countertops - 1 pc</p>	<p>6</p>  <p>Cabinet divider - 1 pc</p>
<p>7</p>  <p>Bottom of the cabinet - 1 pc</p>	<p>8</p>  <p>Cabinet legs - 1 pc</p>	<p>9</p>  <p>Cabinet legs - 1 pc</p>
<p>10</p>  <p>Decorative bar - 1 pc</p>	<p>11</p>  <p>Upper cross bar - 1 pc</p>	<p>12</p>  <p>Decorative bar - 1 pc</p>
<p>13</p>  <p>Upper back panels - 2 pcs</p>	<p>14</p>  <p>Lower back panels - 2 pcs</p>	<p>15</p>  <p>Adjustable shelf - 1 pc</p>

Part List

16

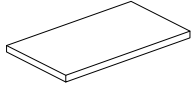

Adjustable shelf - 1 pc

17

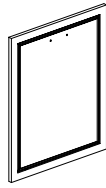

Cabinet door - 1 pc

18

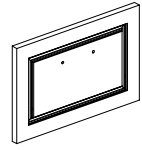

Drawer - Front side - 1 pc

19

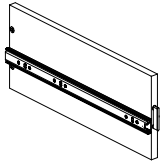

Drawer - Side rails - 1 pc

20

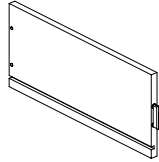

Drawer - Side rails - 1 pc

21

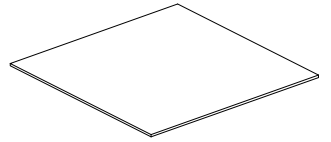

Drawer - Bottom Panels - 2 pcs

22

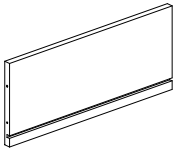

Drawer - Back Panels - 1 pc

23

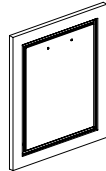

Drawer - Front side - 1 pc

24

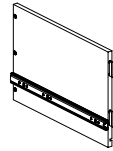

Drawer - Side rails - 1 pc

25

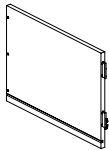





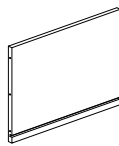



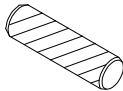
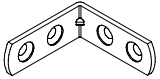

Drawer - Side rails - 1 pc

26

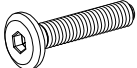
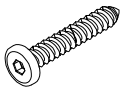

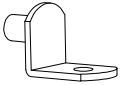
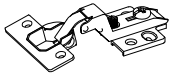
Drawer - Back Panels - 1 pc

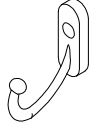
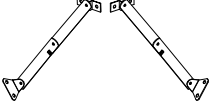
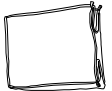
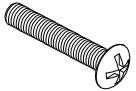
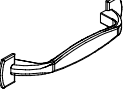
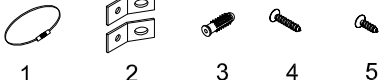
Hardware List

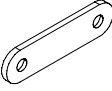
<p>A</p>  <p>Steel Bracket - 10 pcs</p>	<p>B</p>  <p>M3.5 x 15 mm Wood Screws 102 pcs</p>	<p>C</p>  <p>Ø8 x 30 mm Wood dowel 8 pcs</p>
<p>D</p>  <p>Steel Bracket - 4 pcs</p>	<p>E</p>  <p>M4 x 30 mm Wood Screws 18 pcs</p>	<p>F</p>  <p>1/4" x 30 mm Hex-Head bolts 4 pcs</p>
<p>G</p>  <p>1/4" x 50 mm Wood Screws 6 pcs</p>	<p>H</p>  <p>Plastic Wedges 20 pcs</p>	<p>I</p>  <p>Support Pin (9mm) 8 pcs</p>
<p>J</p>  <p>Side Door Hinge - 2 pcs</p>	<p>K</p>  <p>1 2 Clamp pin 2 set</p>	<p>L</p>  <p>Hanger 4 pcs</p>
<p>M</p>  <p>Crankshaft 1 set (1L-1R)</p>	<p>N</p>  <p>Cloth Bag - 1 pc</p>	<p>O</p>  <p>M4 x 20 mm Truss Head Wood Screws 6 pcs</p>
<p>P</p>  <p>Cabinet Door 3 pcs</p>	<p>Q</p>  <p>1 2 3 4 5 Anti Fall 2 set</p>	<p>R</p>  <p>Allen Key 1 pc</p>
<p>S</p>  <p>Steel Bracket 2 pcs</p>		

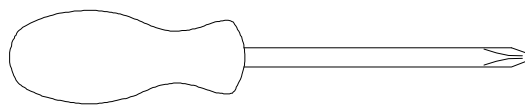

Assembly Tools Required (Not Included)

STEP 1: Following below illustration:

C

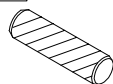

4pcs

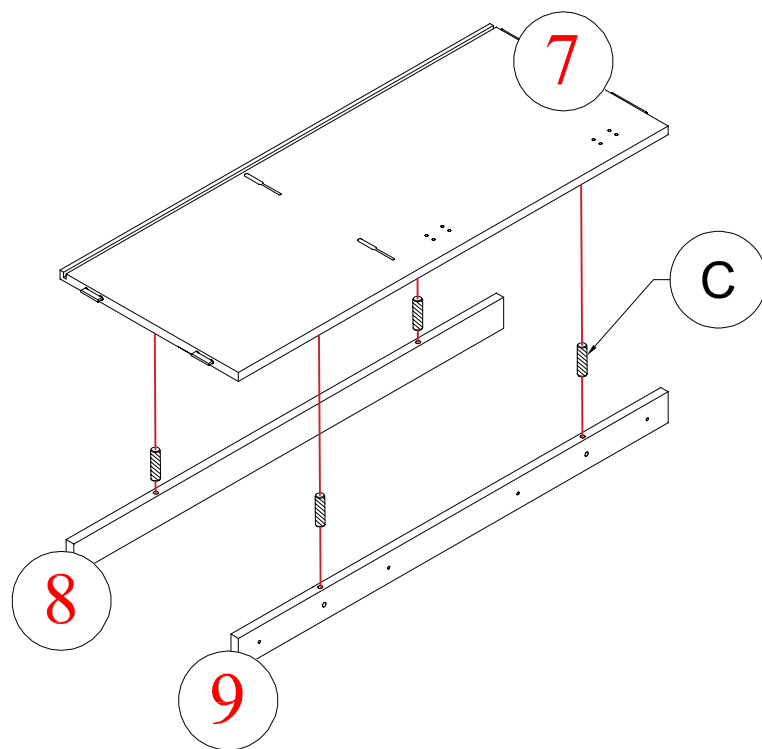

STEP 2: Following below illustration:

A



6pcs

B



12pcs

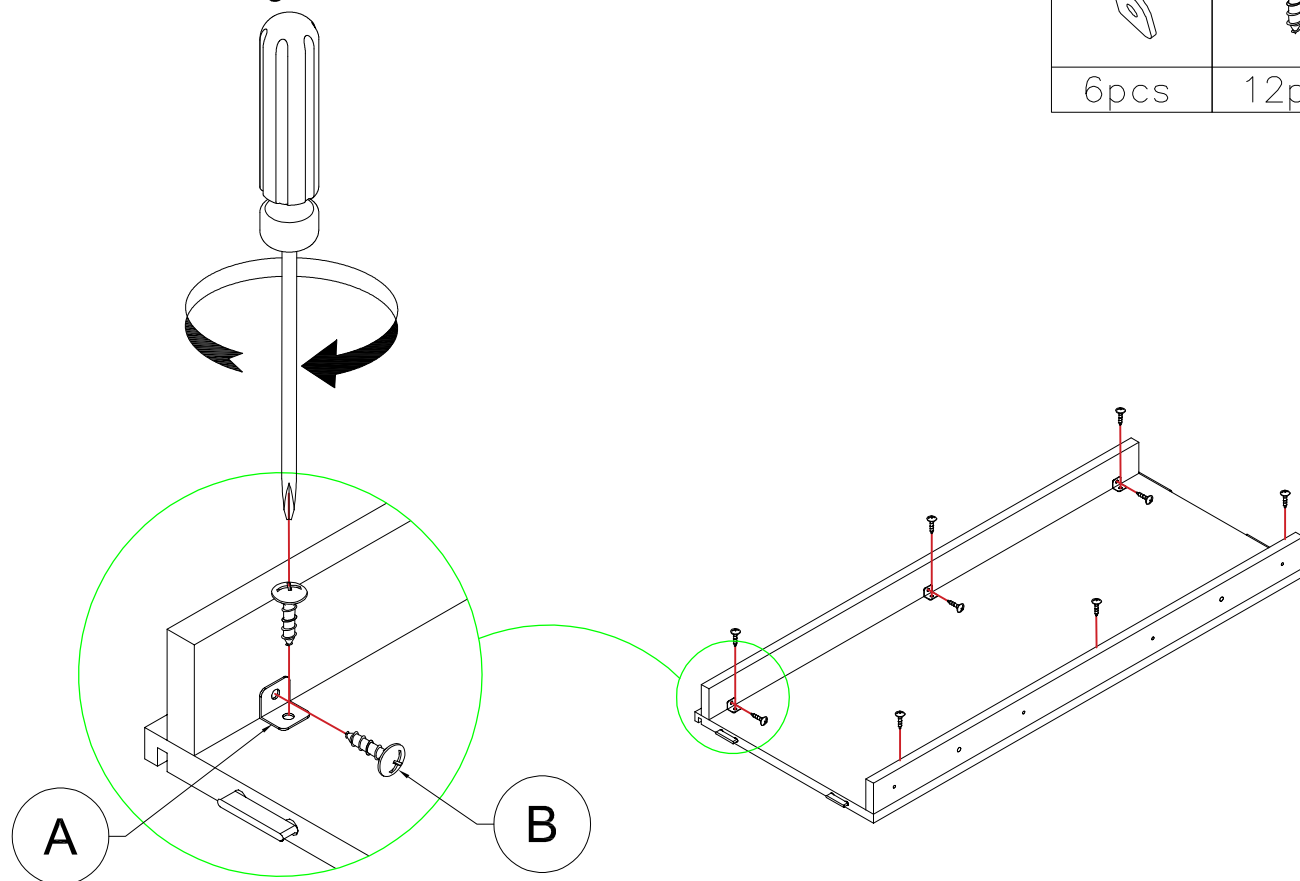

6

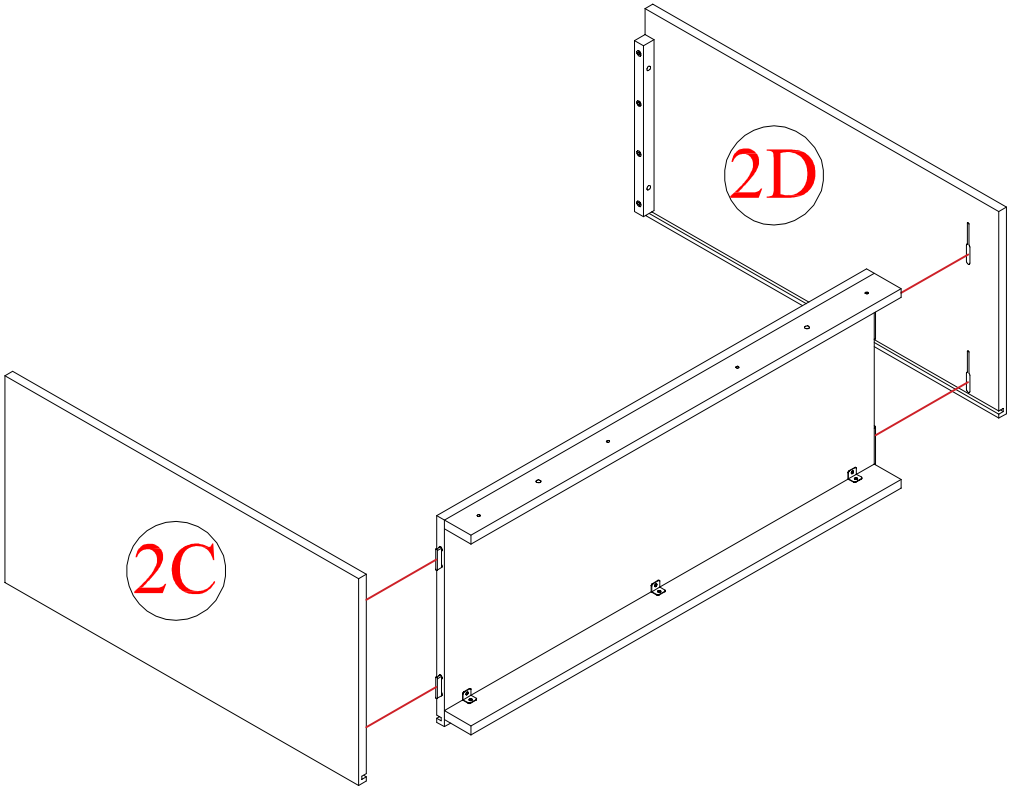

STEP 3: Following below illustration:

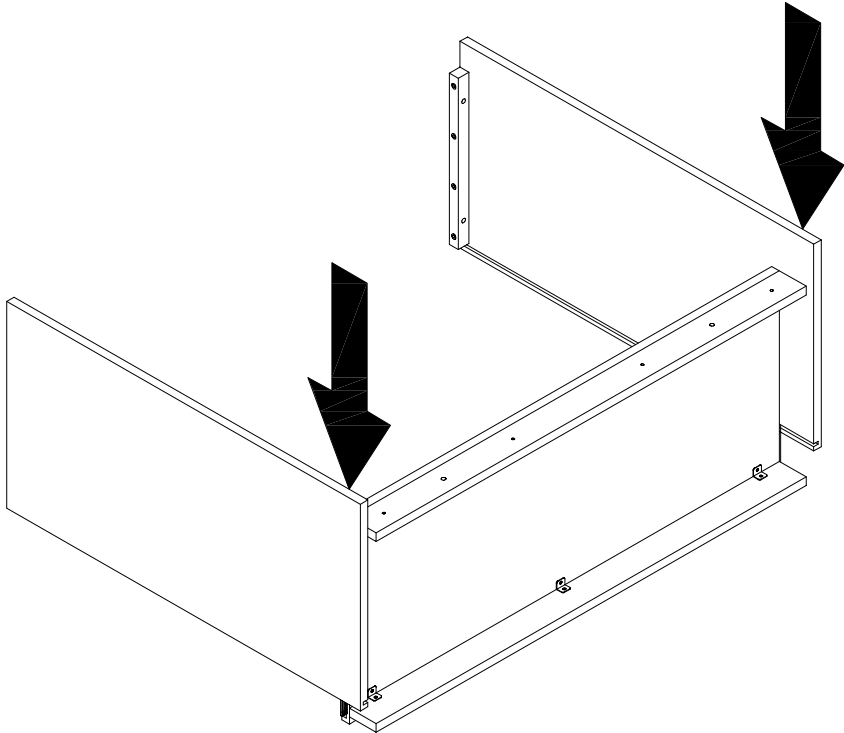

STEP 4: Following below illustration:



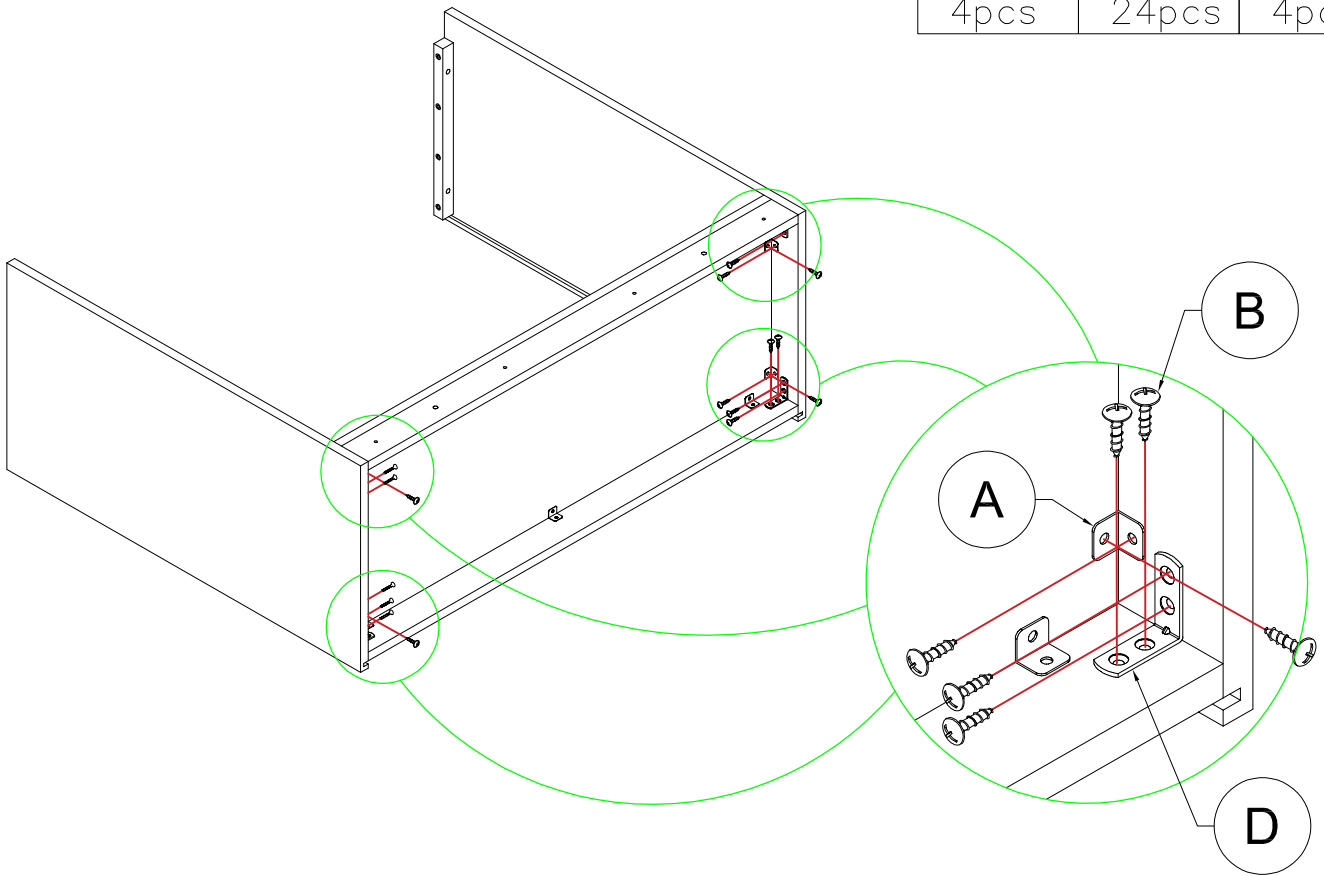

STEP 5: Following below illustration:

A 	B 	D 
4pcs	24pcs	4pcs

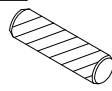

STEP 6: Following below illustration:

C 	E 
2pcs	4pcs

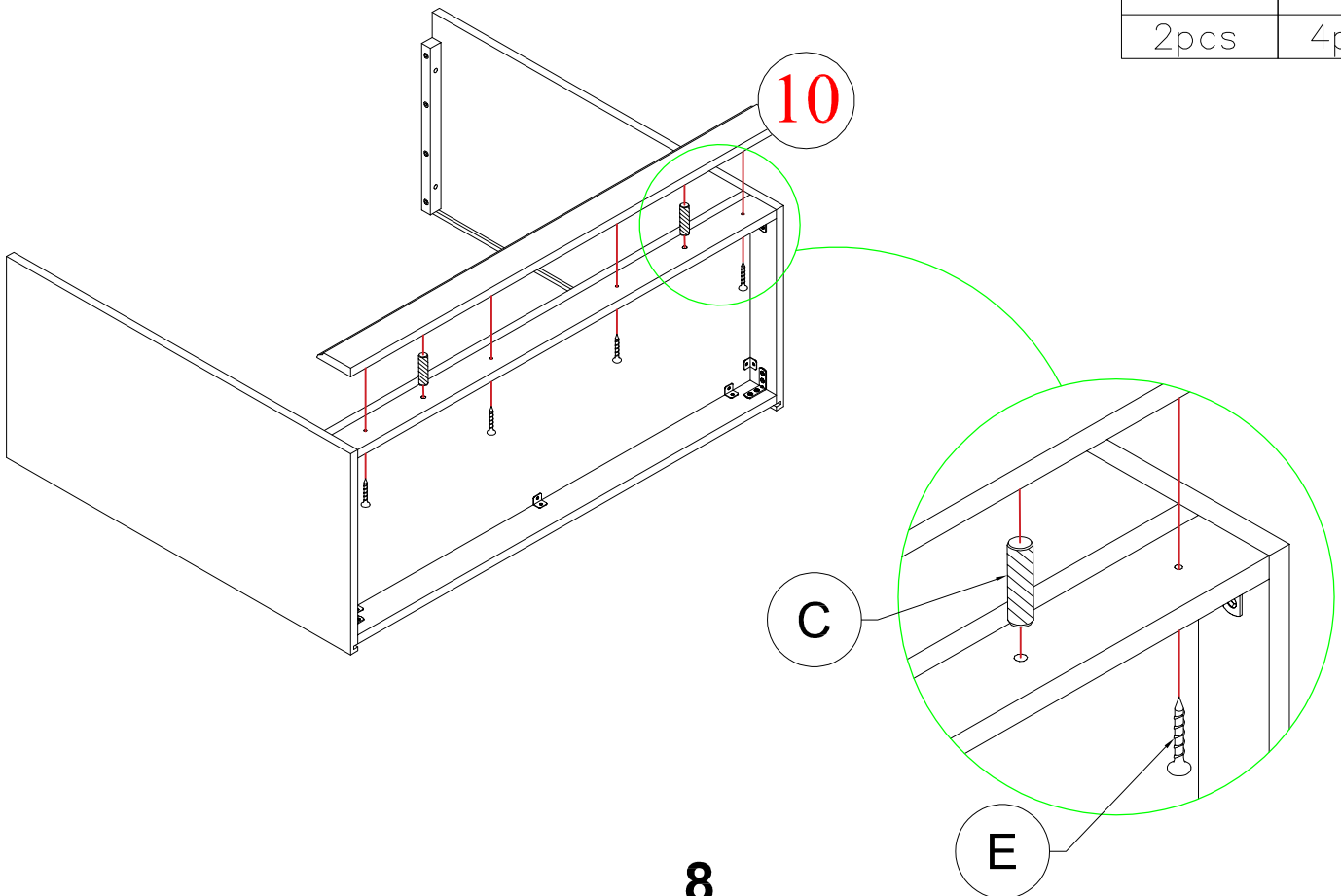

STEP 7: Following below illustration:

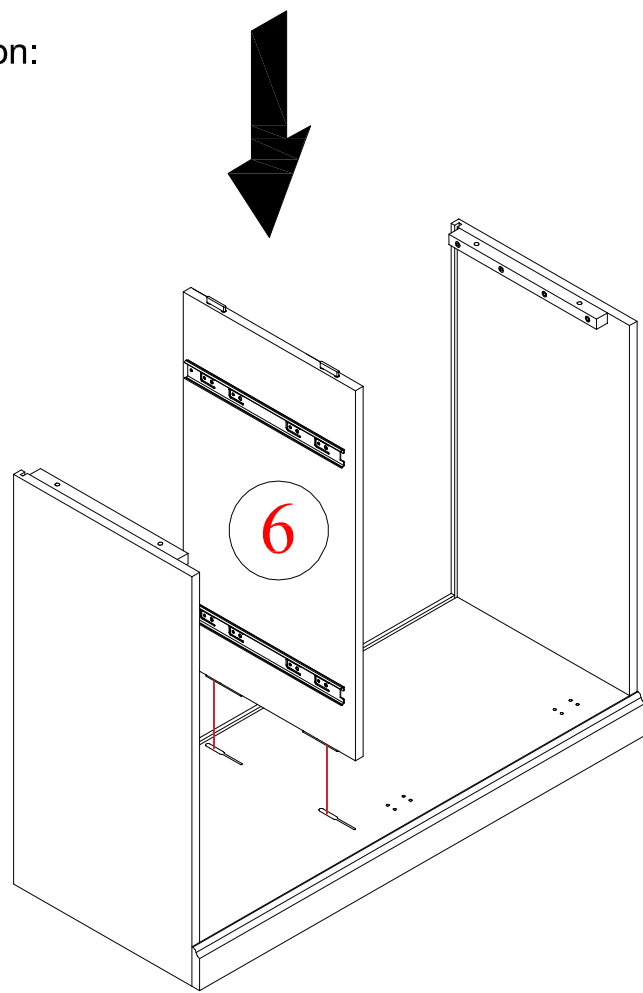

STEP 8: Following below illustration:

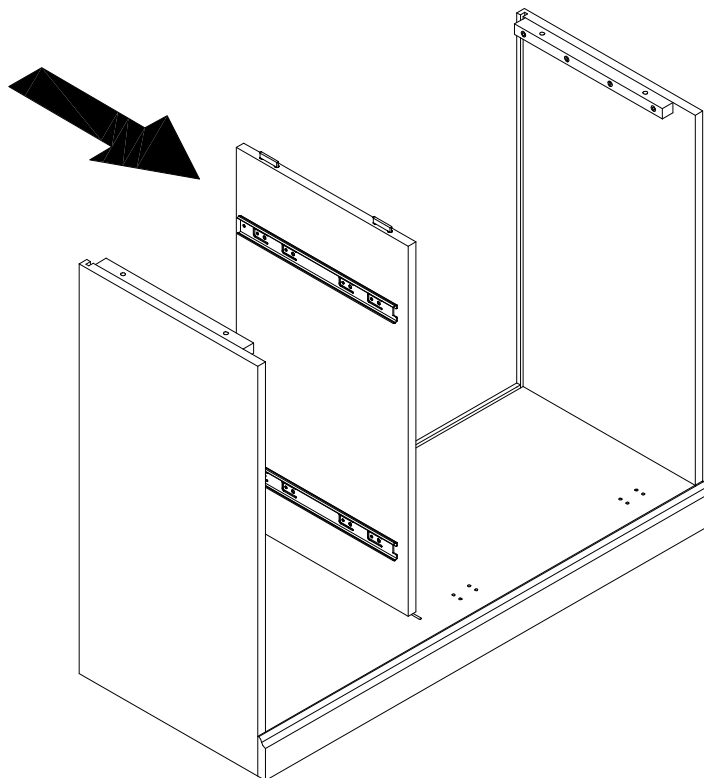

STEP 9: Following below illustration:

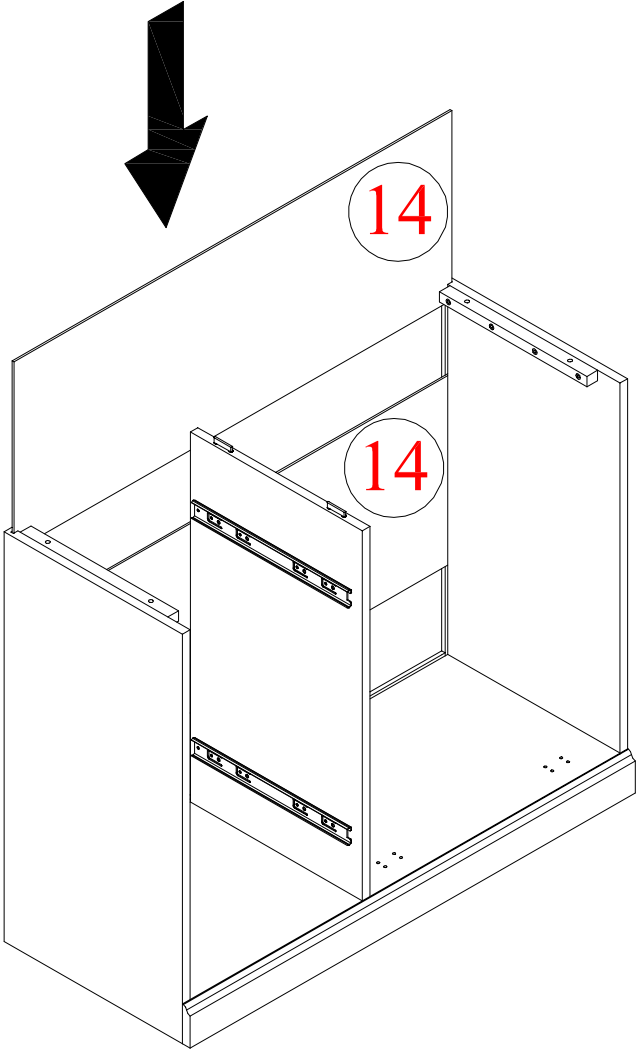

STEP 10: Following below illustration:

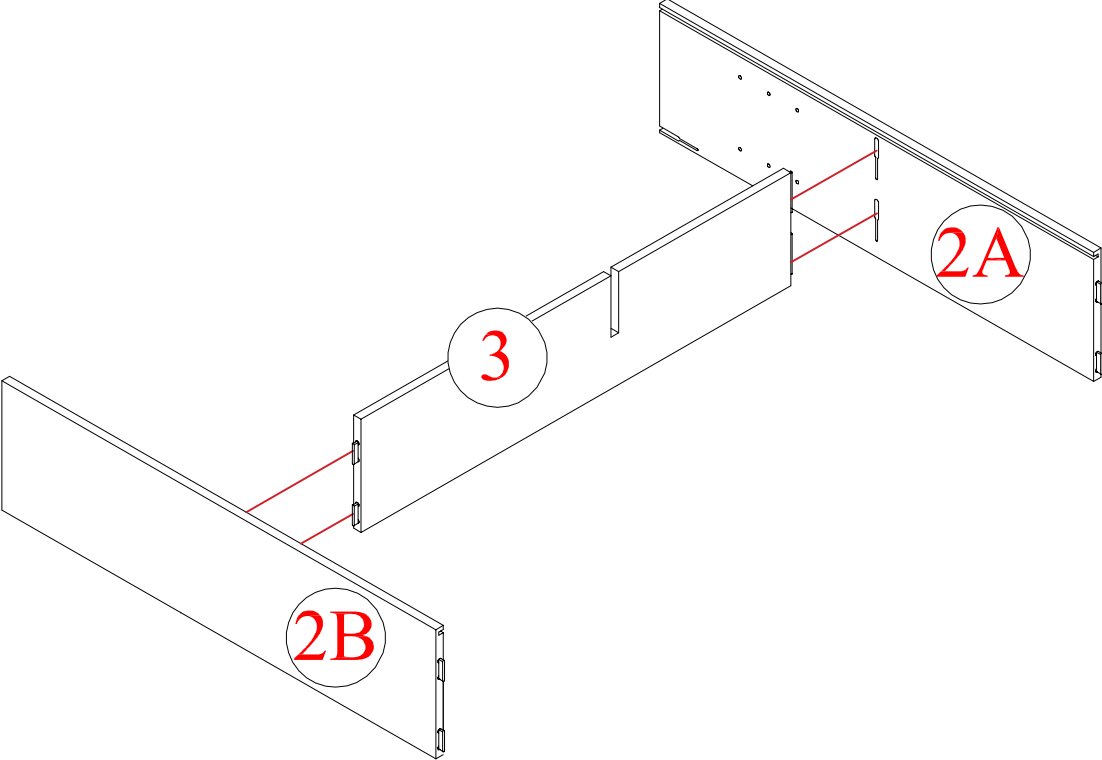

STEP 11: Following below illustration:

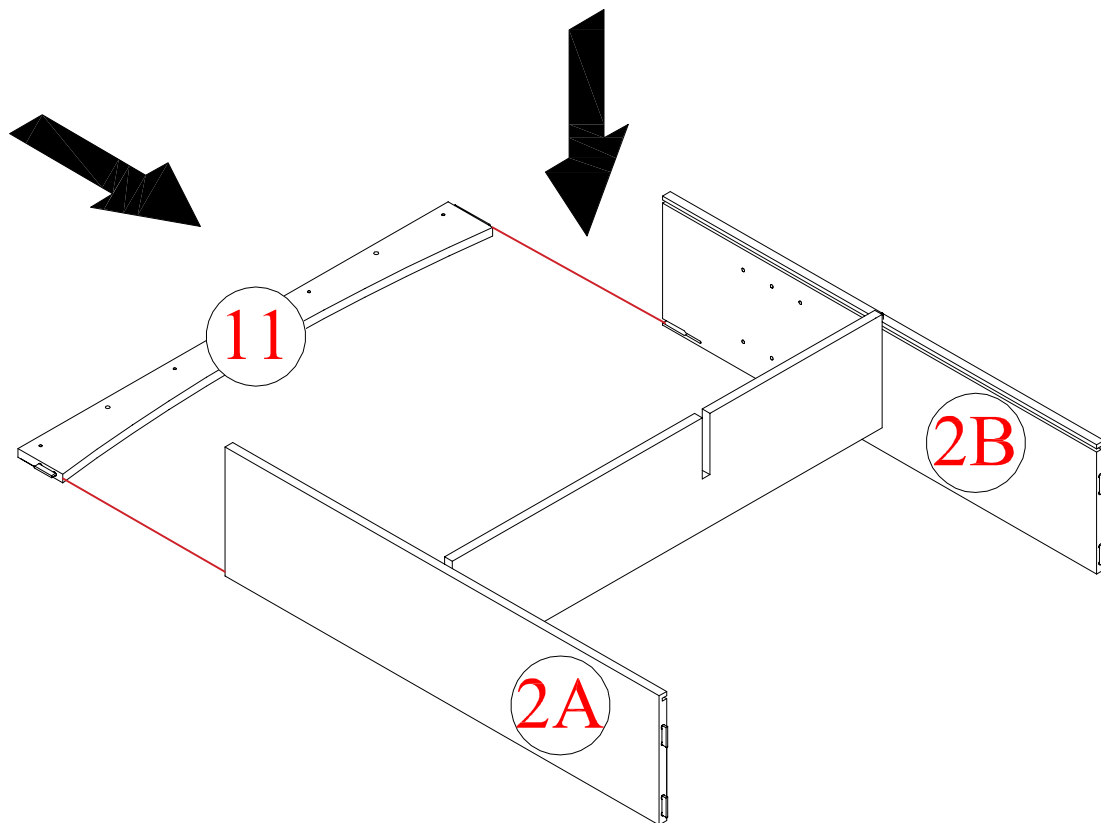

STEP 12: Following below illustration:

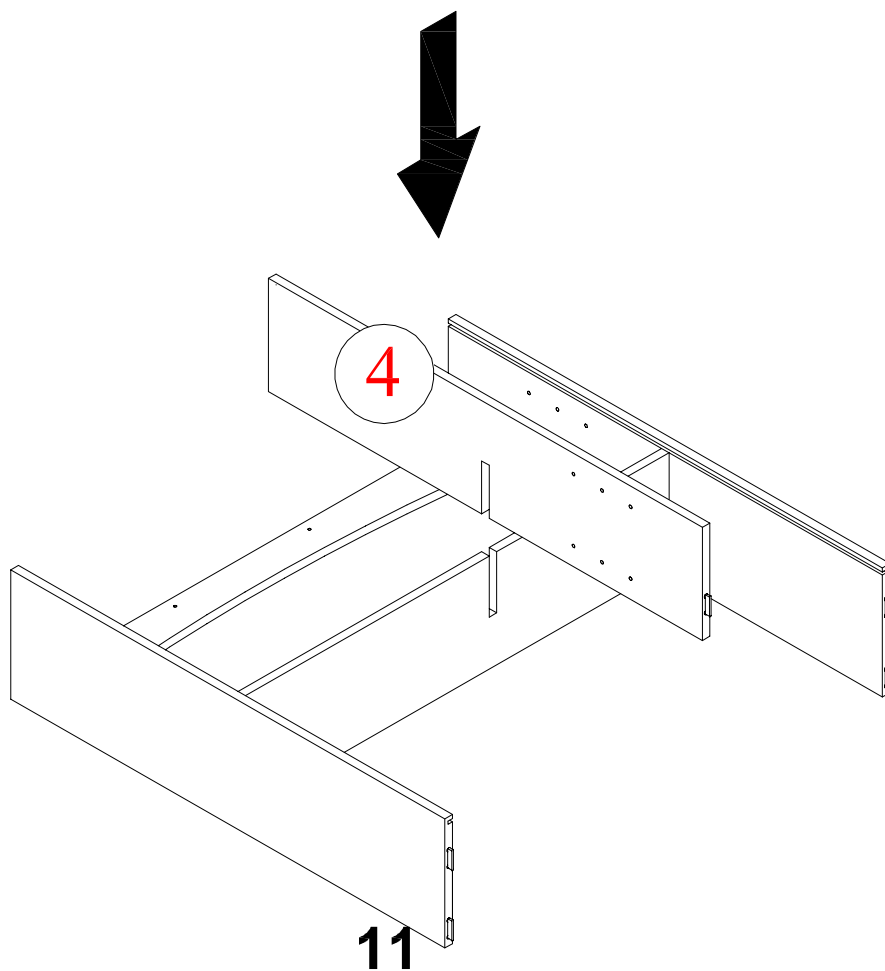

STEP 13: Following below illustration:

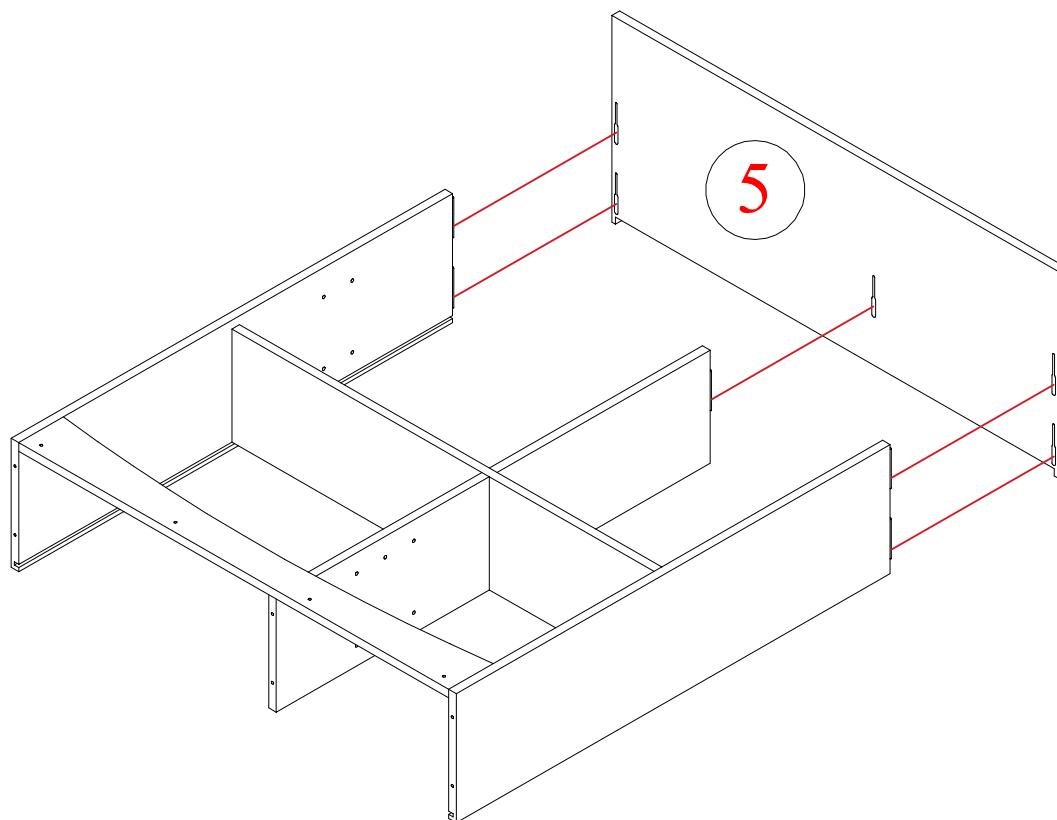

STEP 14: Following below illustration:

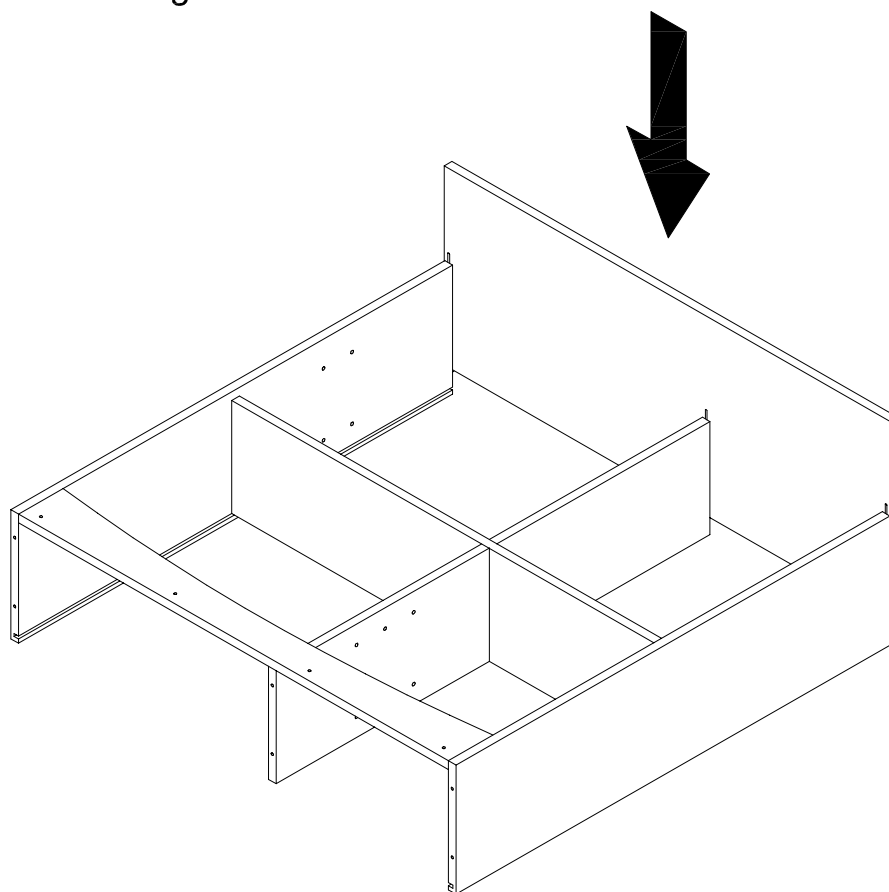

12

STEP 15: Following below illustration:

C

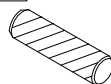

2pcs

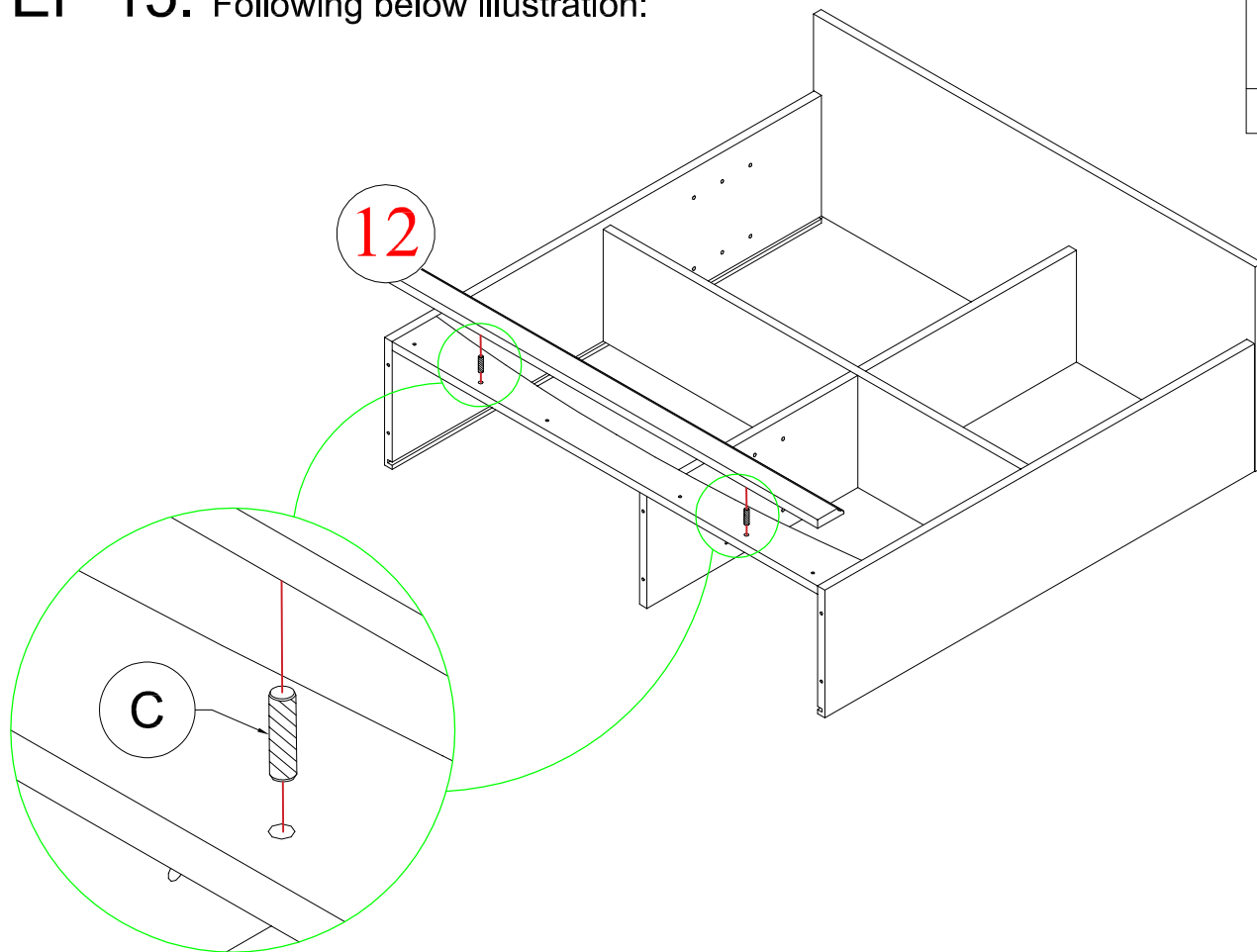

STEP 16: Following below illustration:

E



4pcs

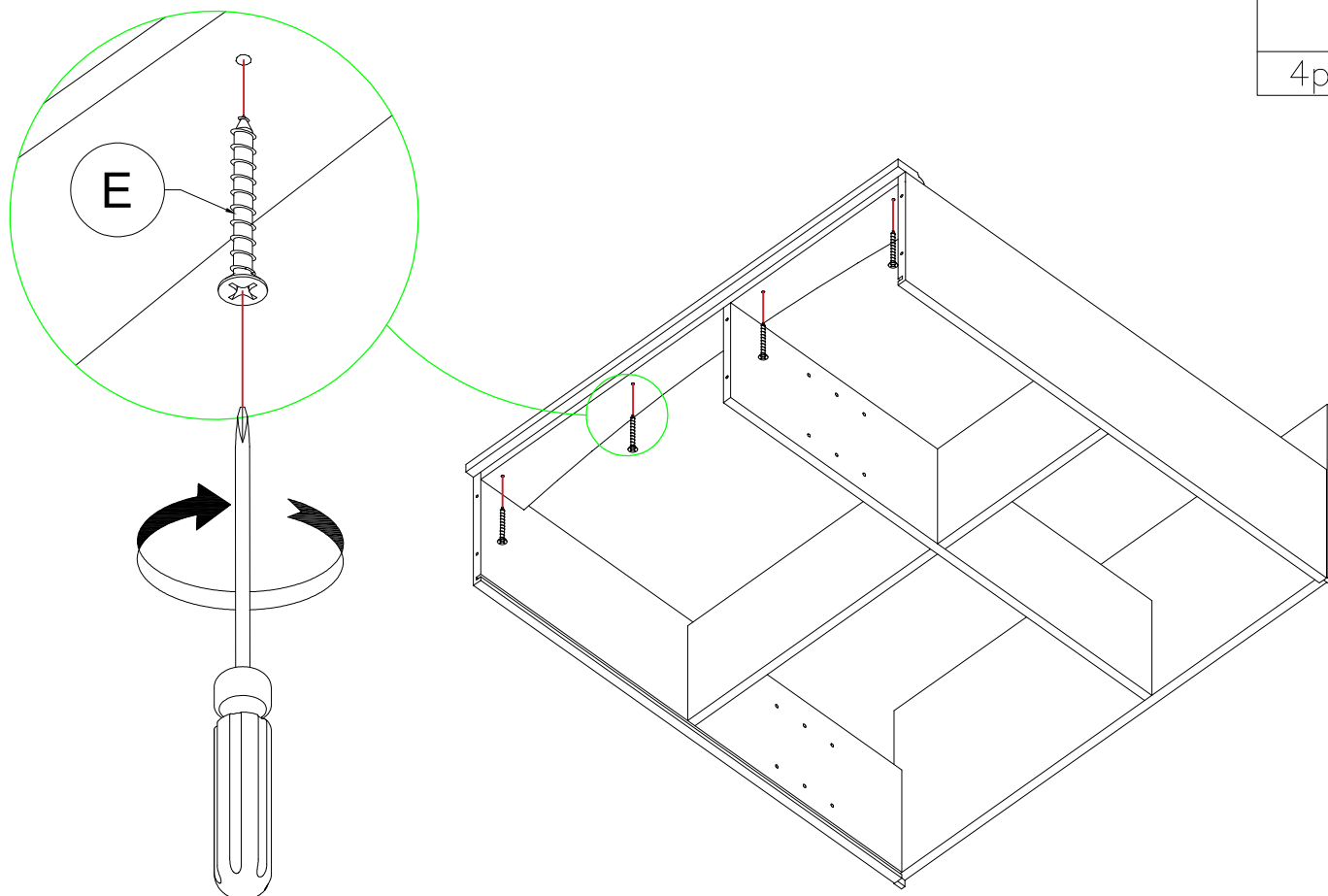

13

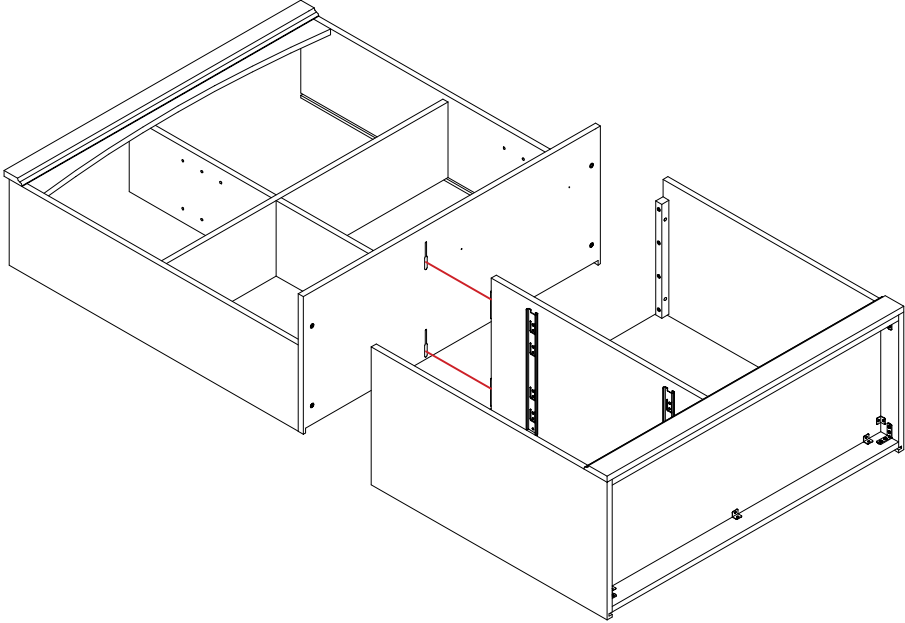

STEP 17: Following below illustration:

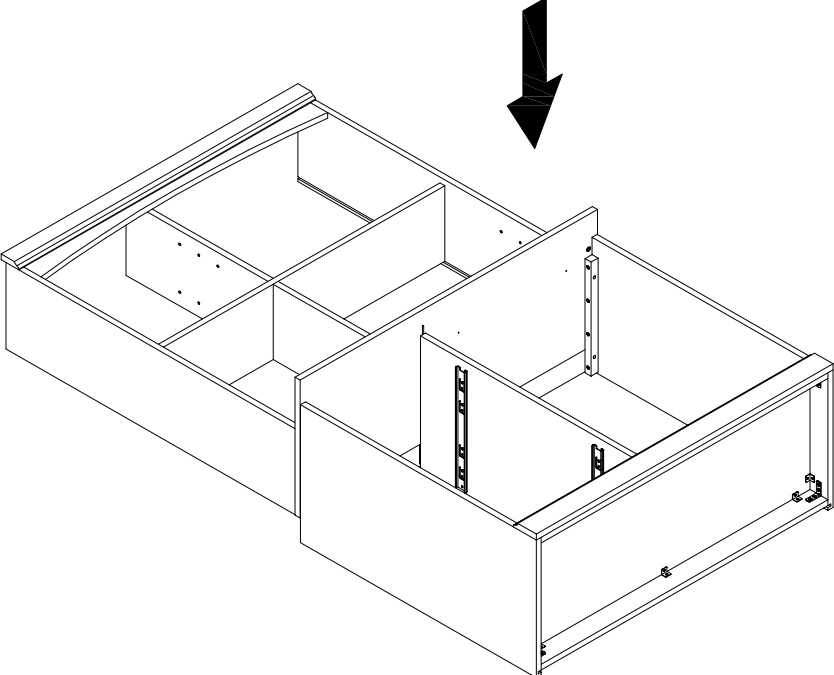

STEP 18: Following below illustration:

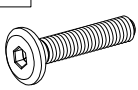

STEP 19: Following below illustration:

L	B	F
		
2pcs	2pcs	4pcs

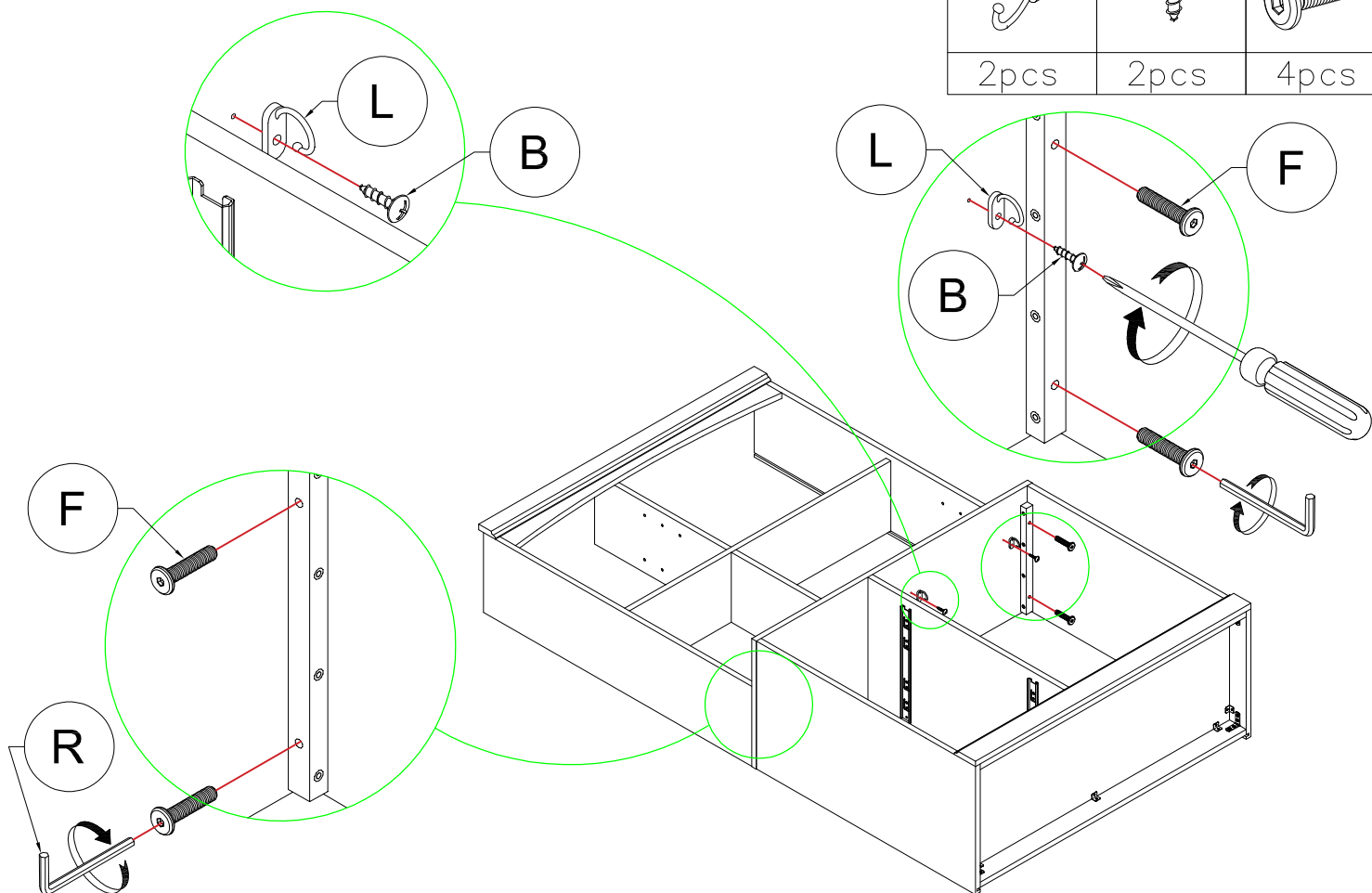

STEP 20: Following below illustration:

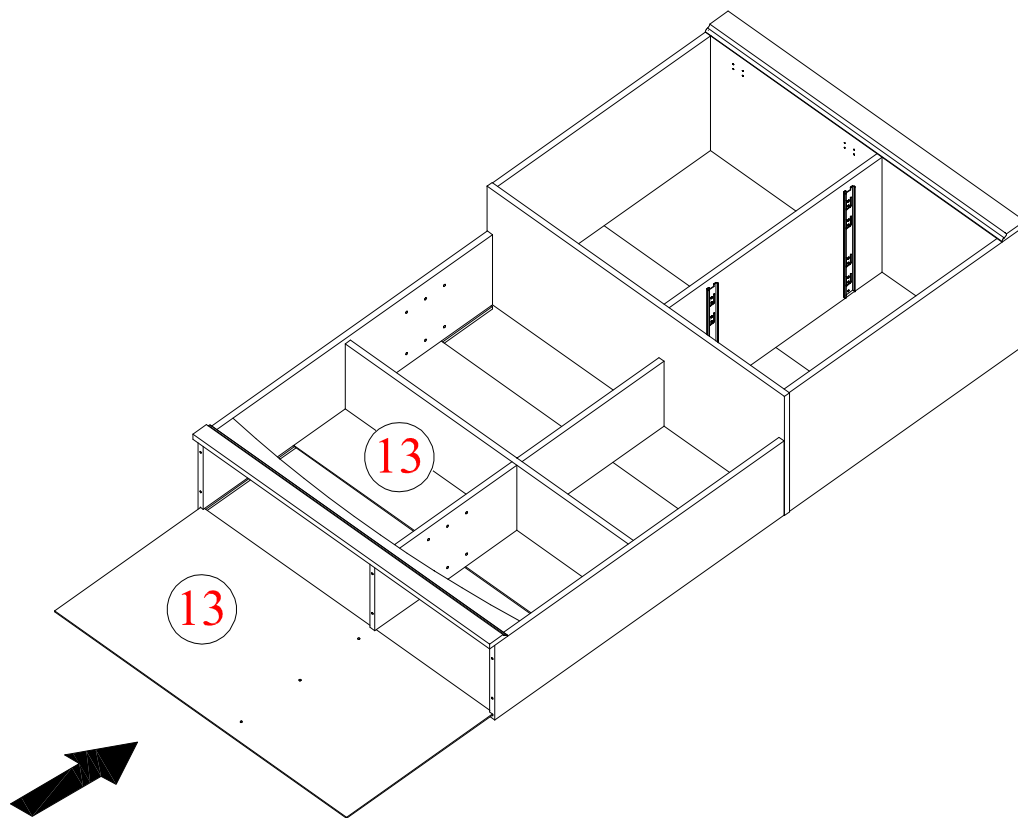

STEP 21: Following below illustration:

G



6pcs

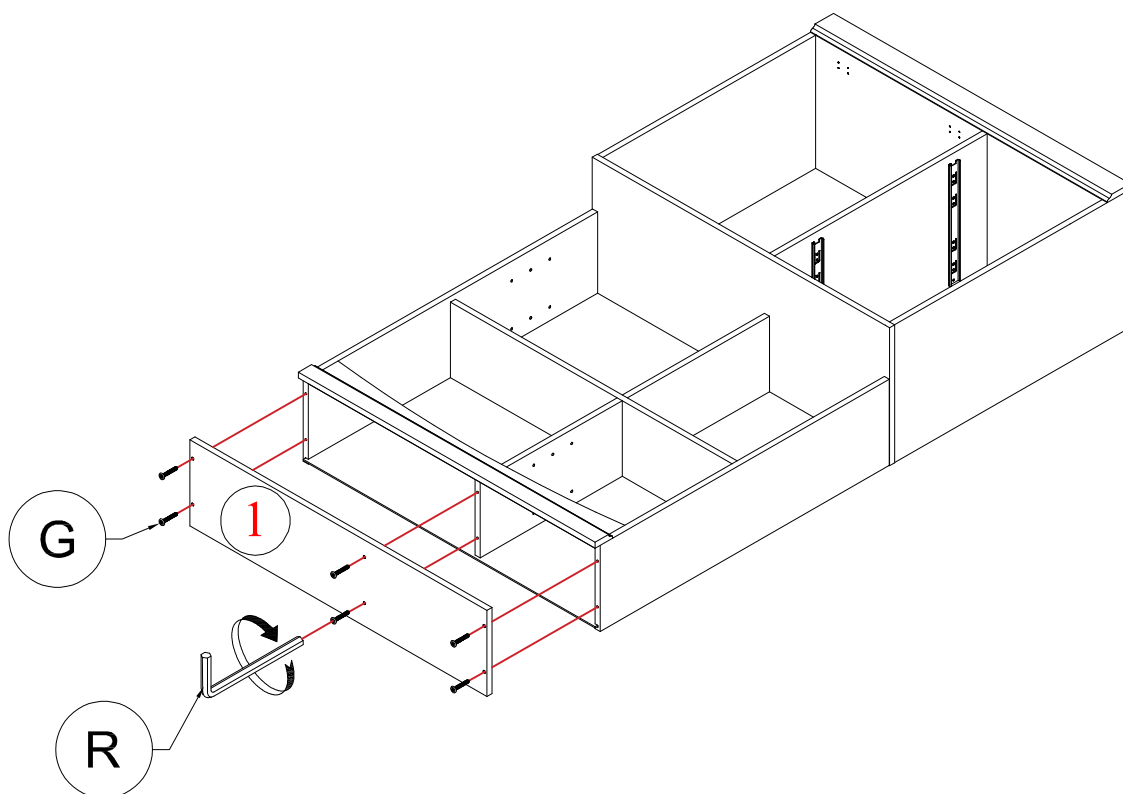

STEP 22: Following below illustration:

H



20pcs



B

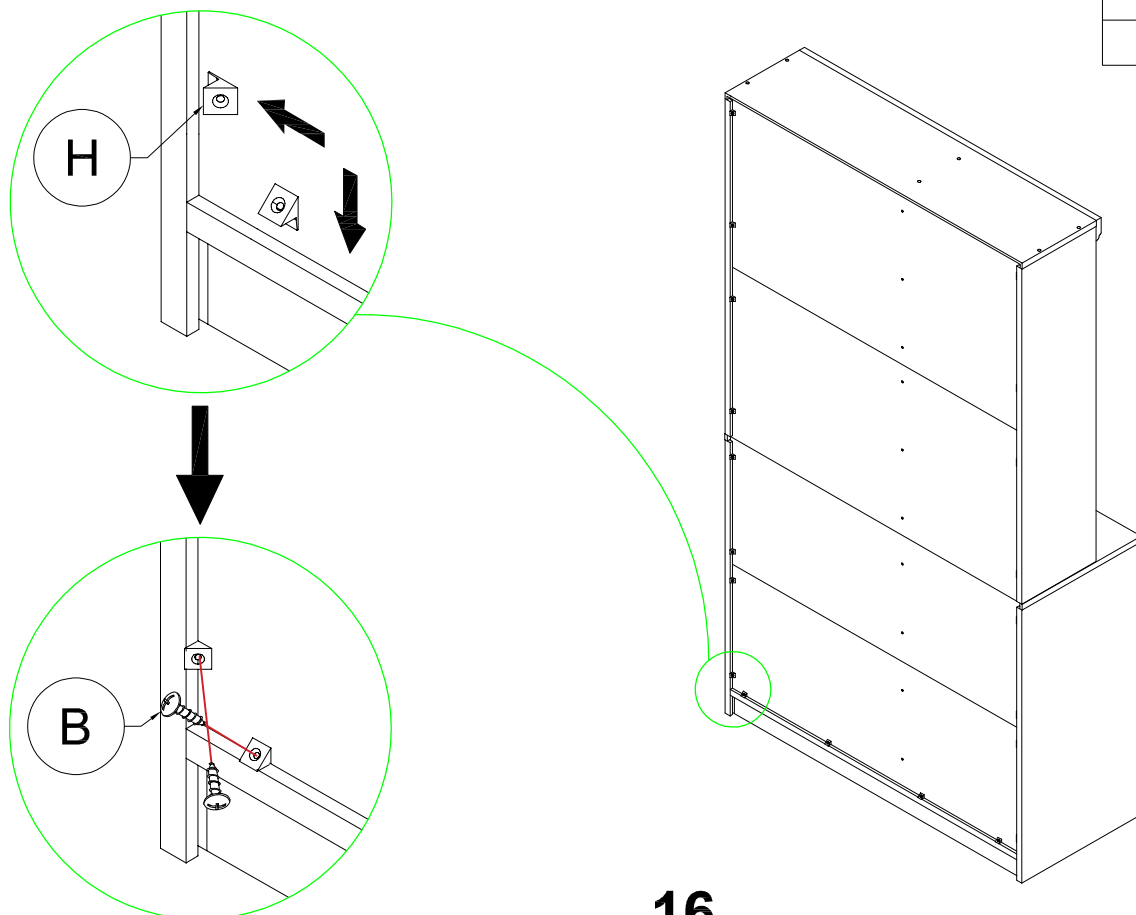

20pcs

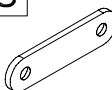

STEP 23: Following below illustration:

S		B	
	2pcs		14pcs

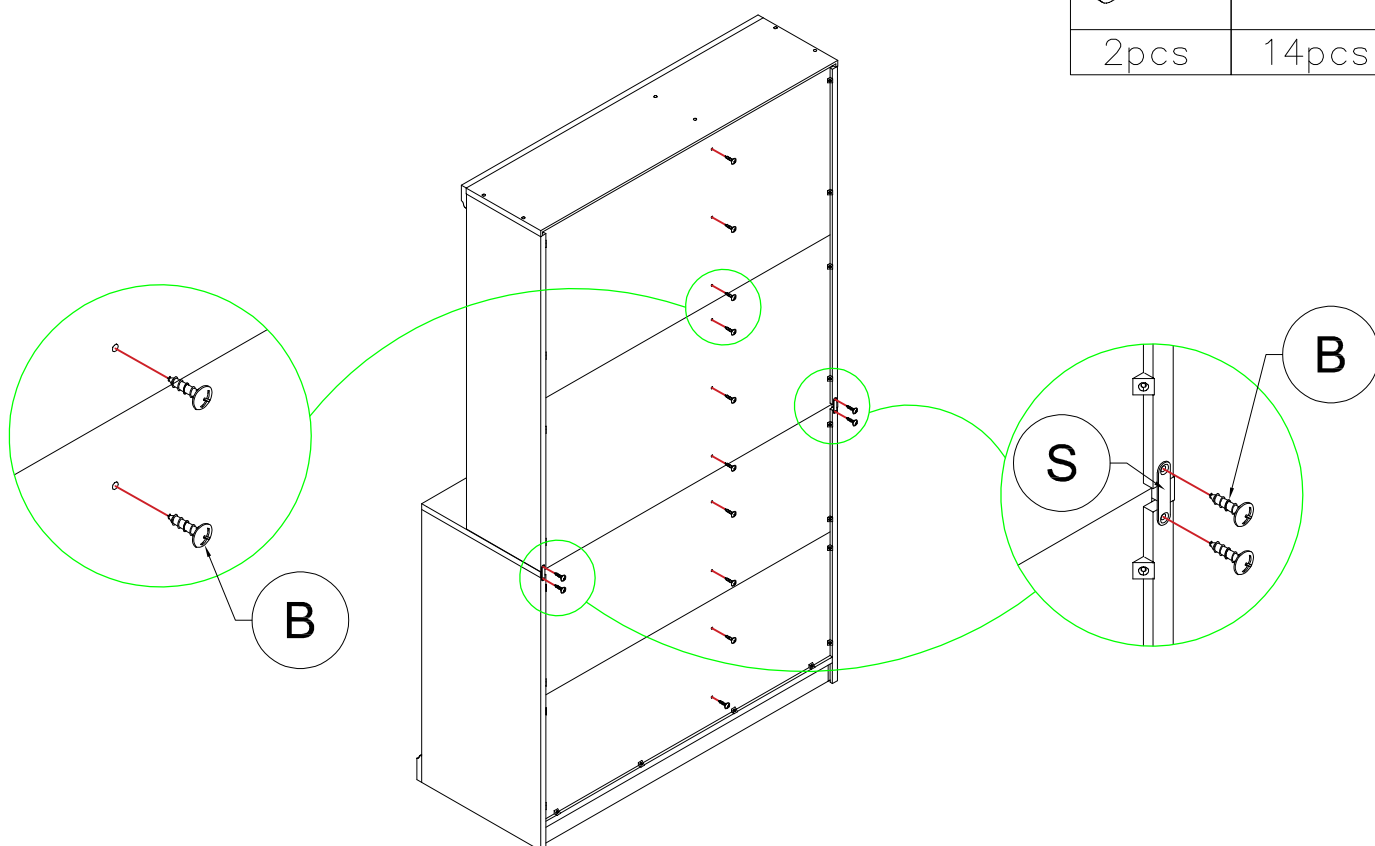



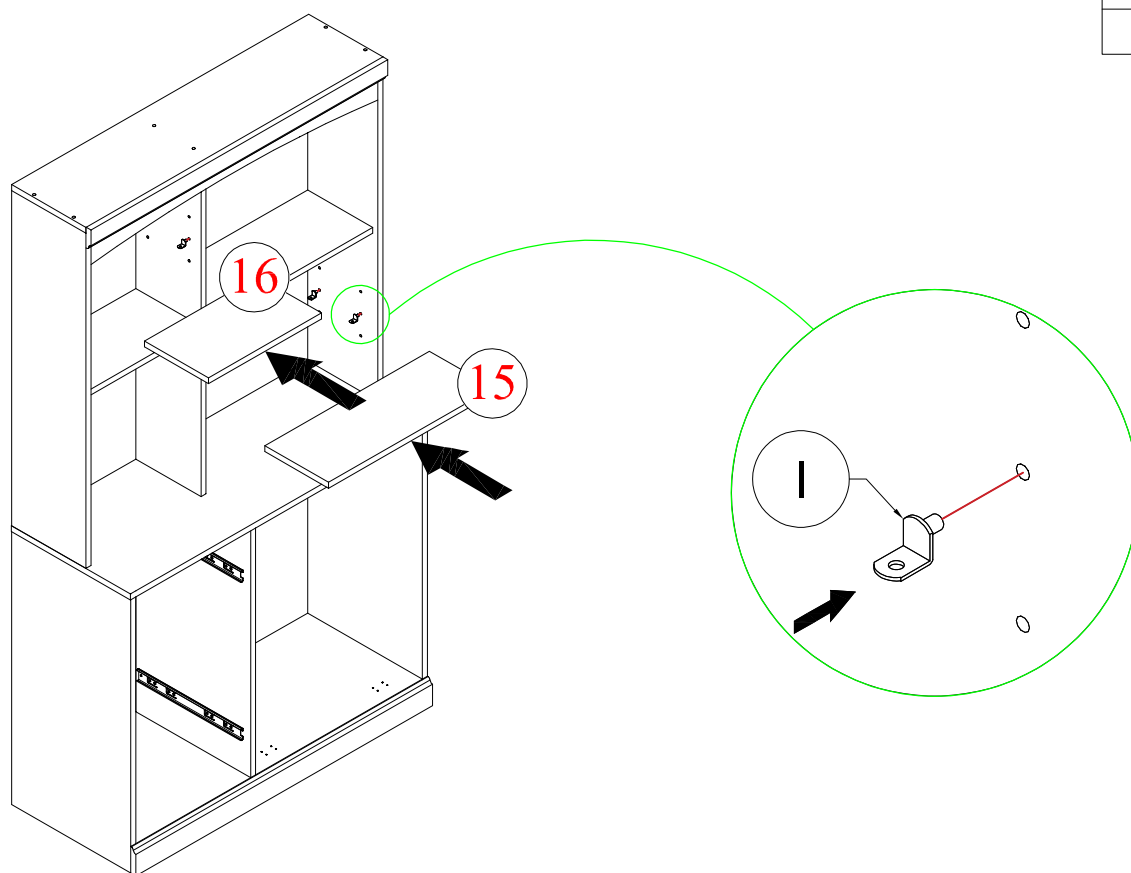

STEP 24: Following below illustration:

I	
	8pcs

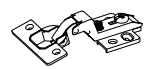

STEP 25: Following below illustration:

J 	B 
2pcs	10pcs
K-2 	L 
2pcs	2pcs

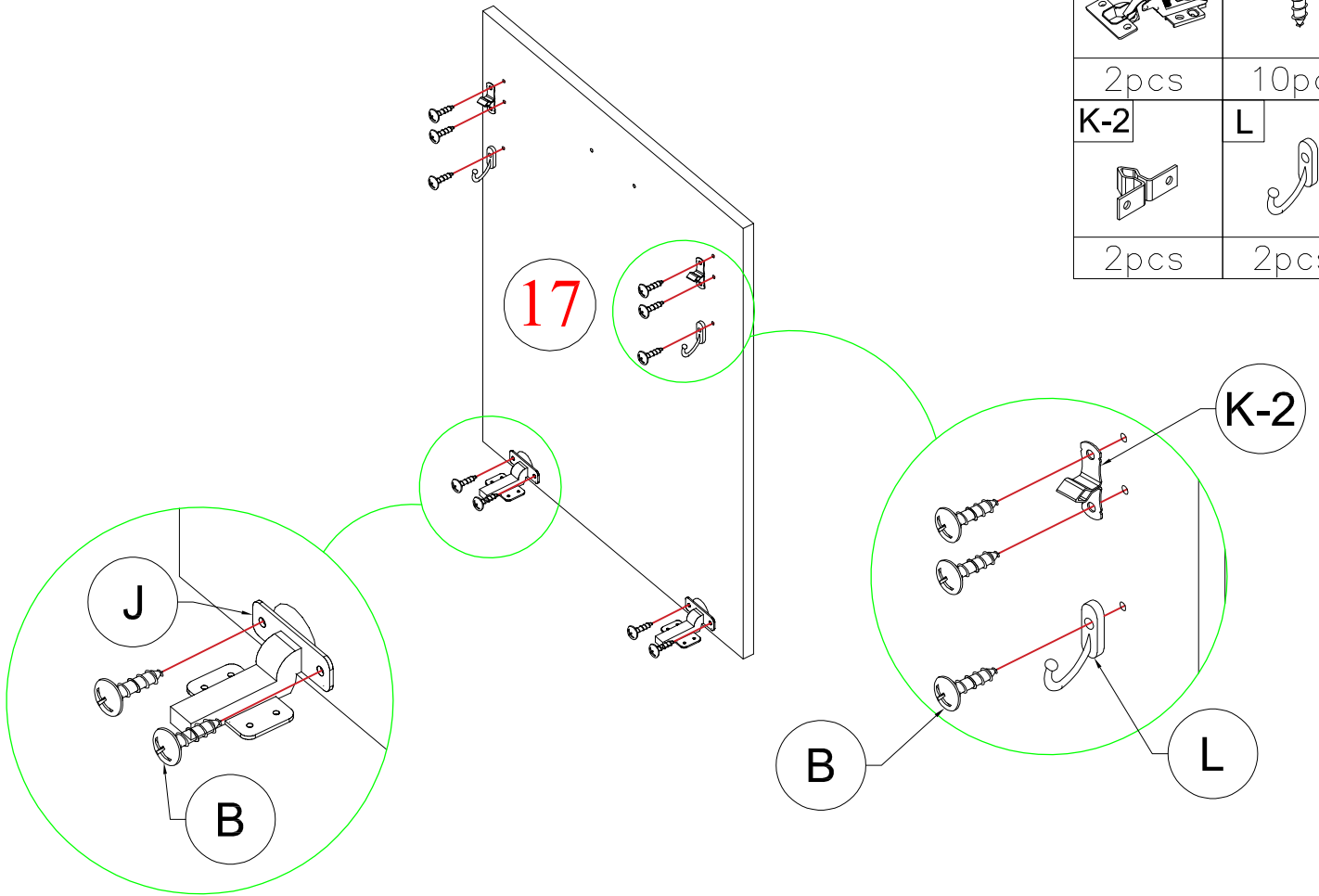

STEP 26: Following below illustration:

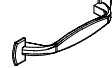
O 	P 
2pcs	1pc

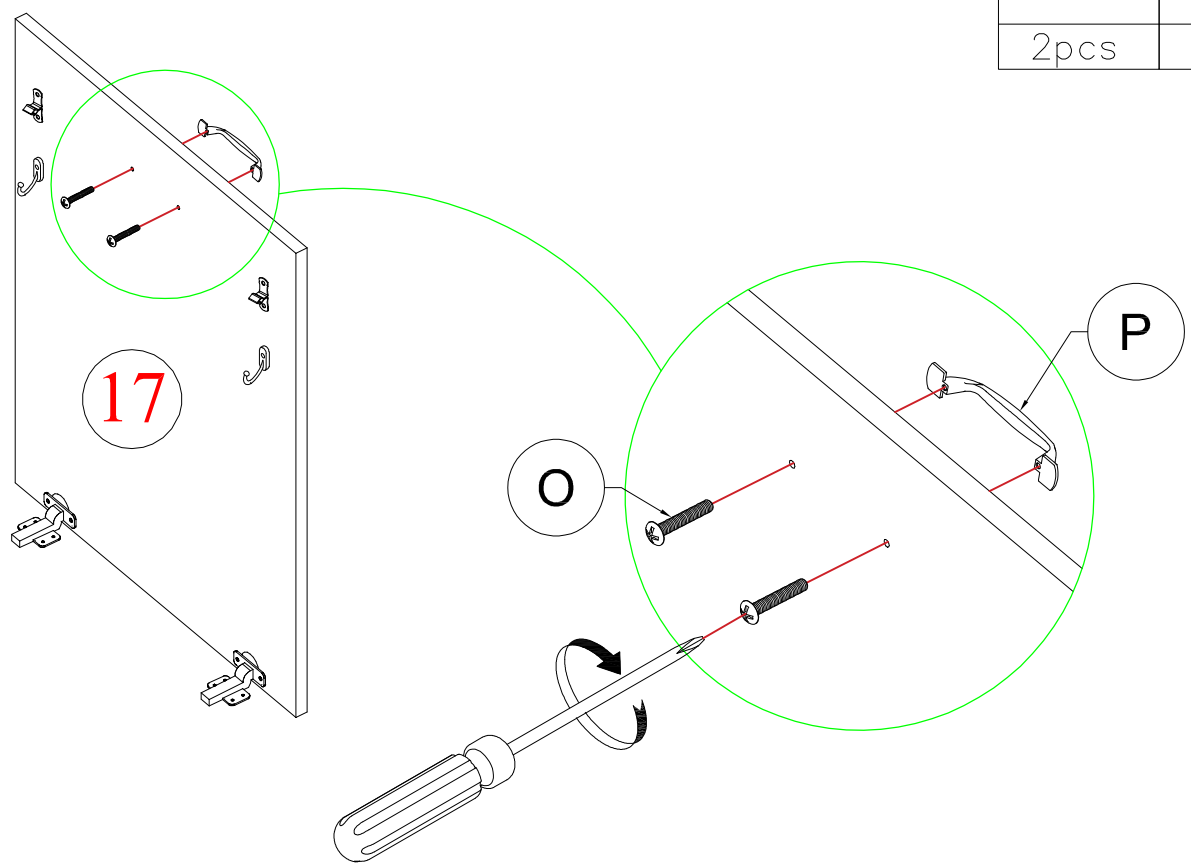

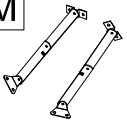

STEP 27: Following below illustration:

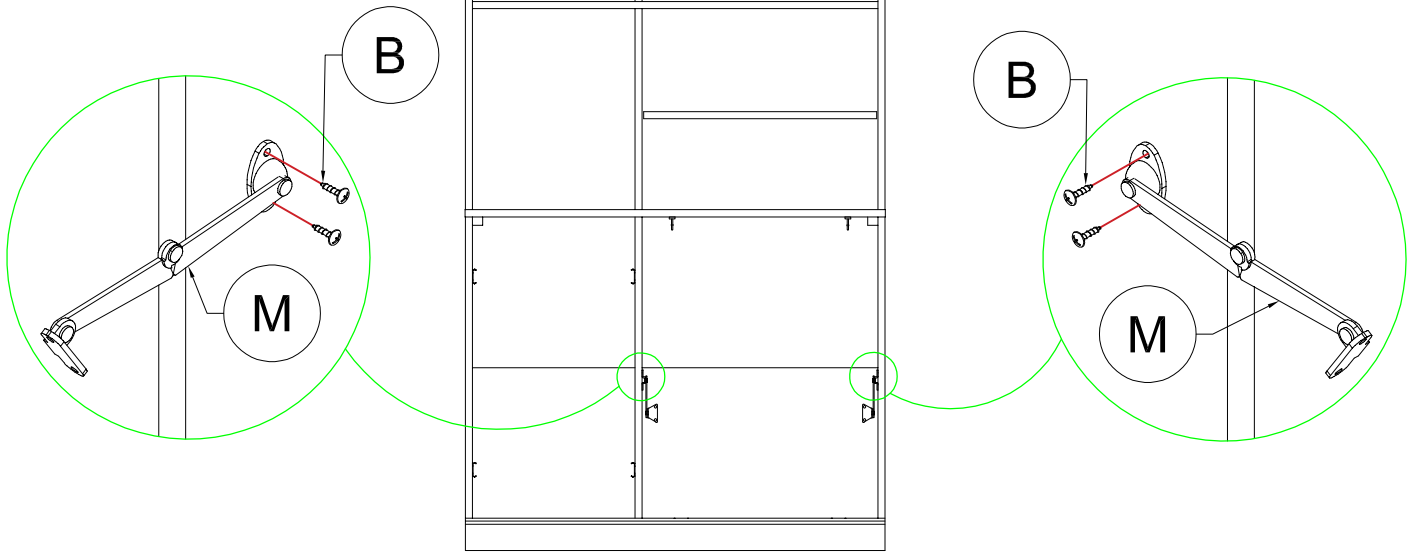
B		M	
4pcs		1set	



STEP 28: Following below illustration:

K-1		B	
2pcs		16pcs	

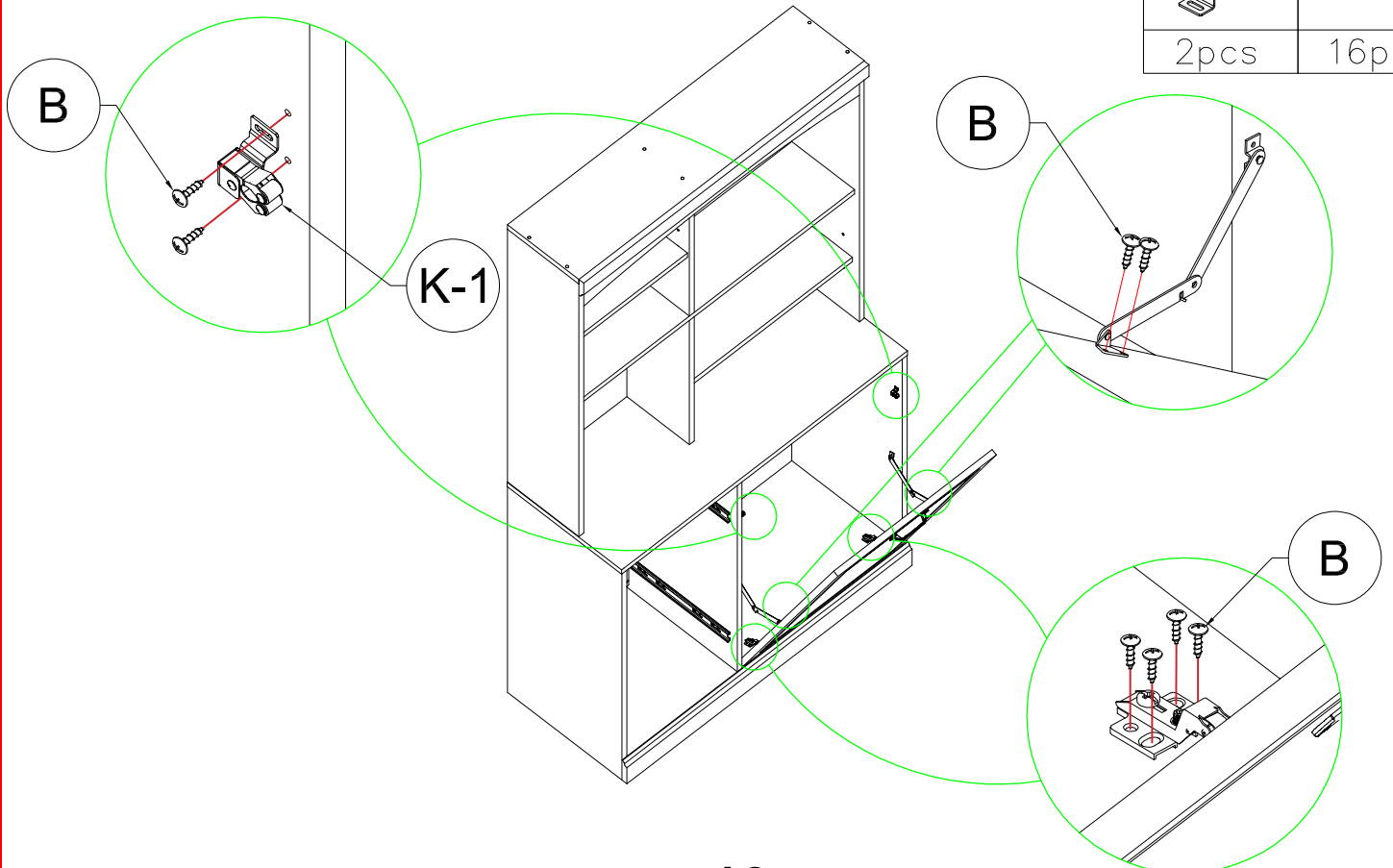

STEP 29: Following below illustration:

N



1pc

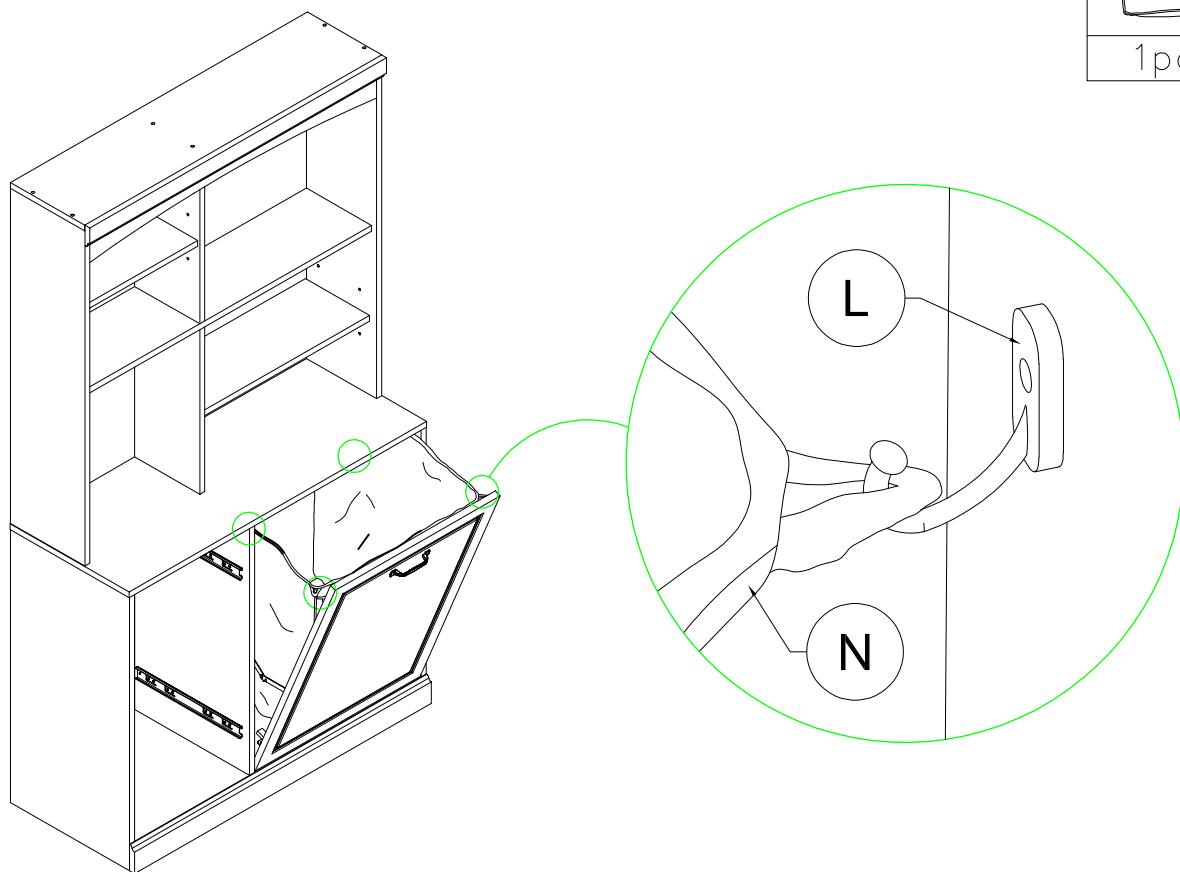

STEP 30: Following below illustration:

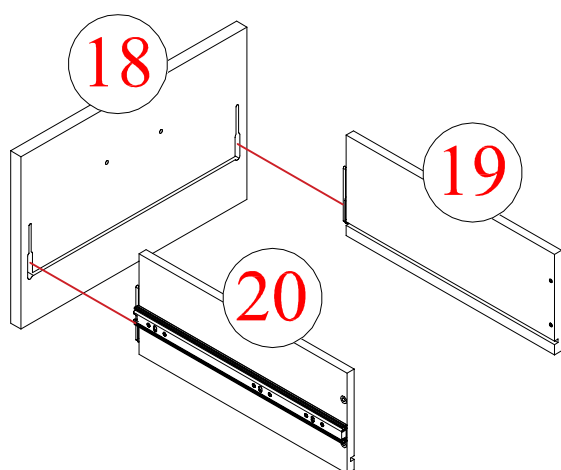

STEP 31: Following below illustration:

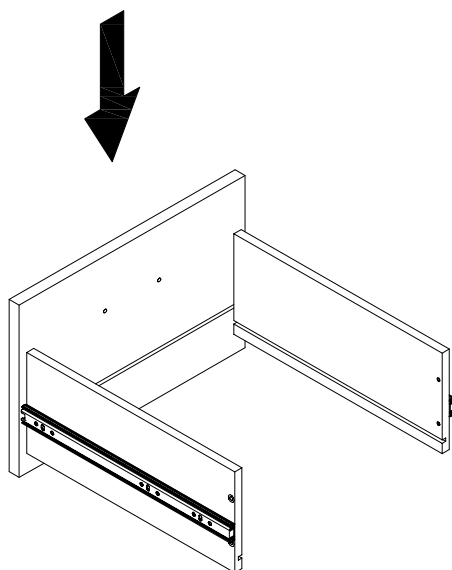

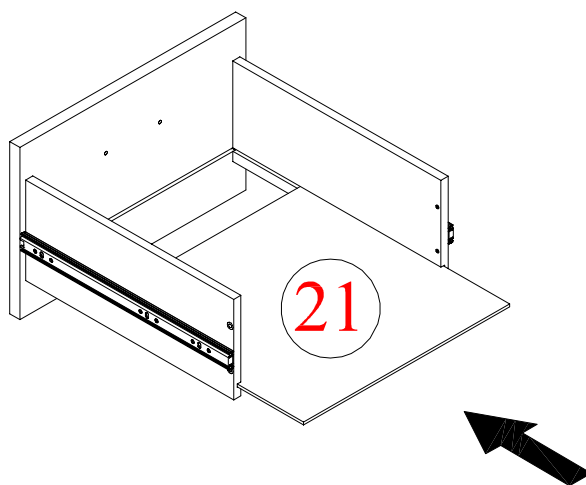

STEP 32: Following below illustration:

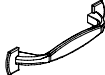

21

STEP 33: Following below illustration:

O	P	E
		
2pcs	1pc	4pcs

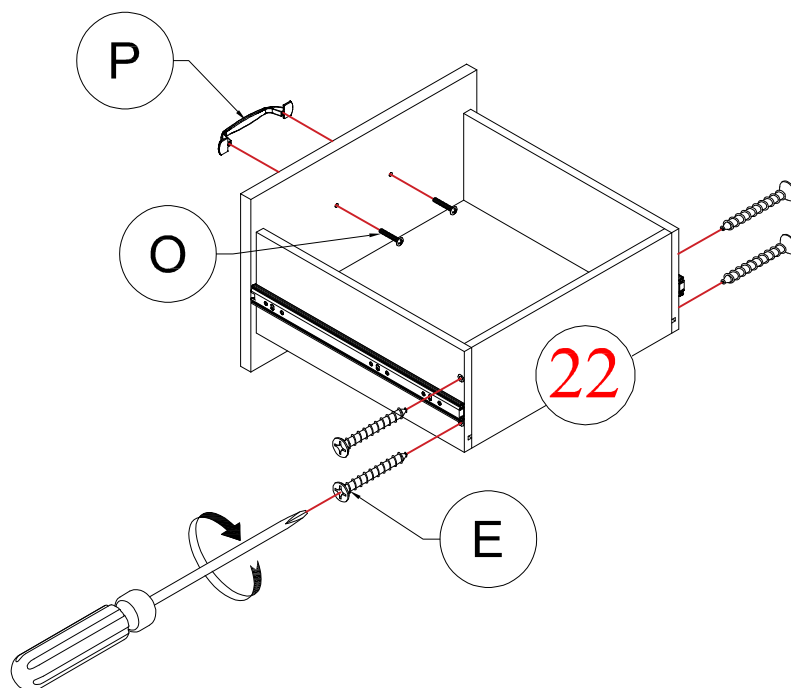

STEP 34: Following below illustration:

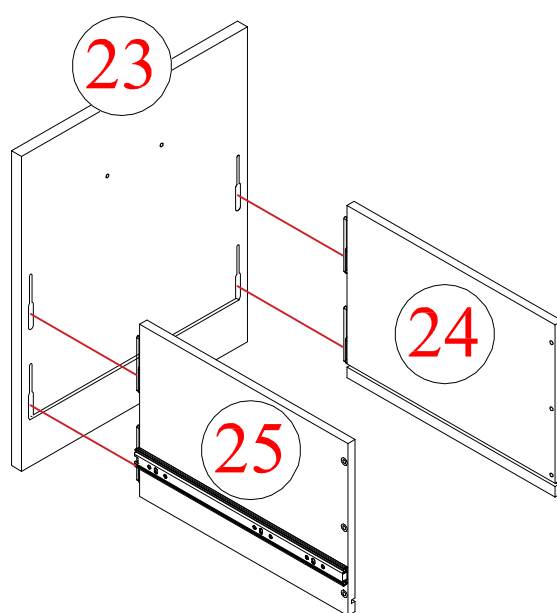

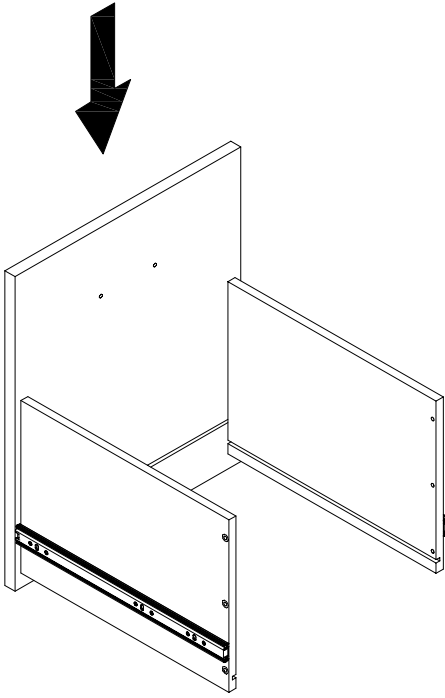

STEP 35: Following below illustration:

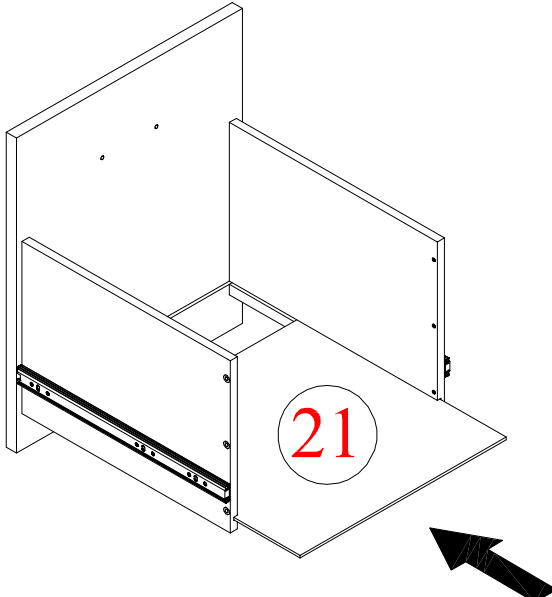

STEP 36: Following below illustration:

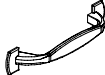

STEP 37: Following below illustration:

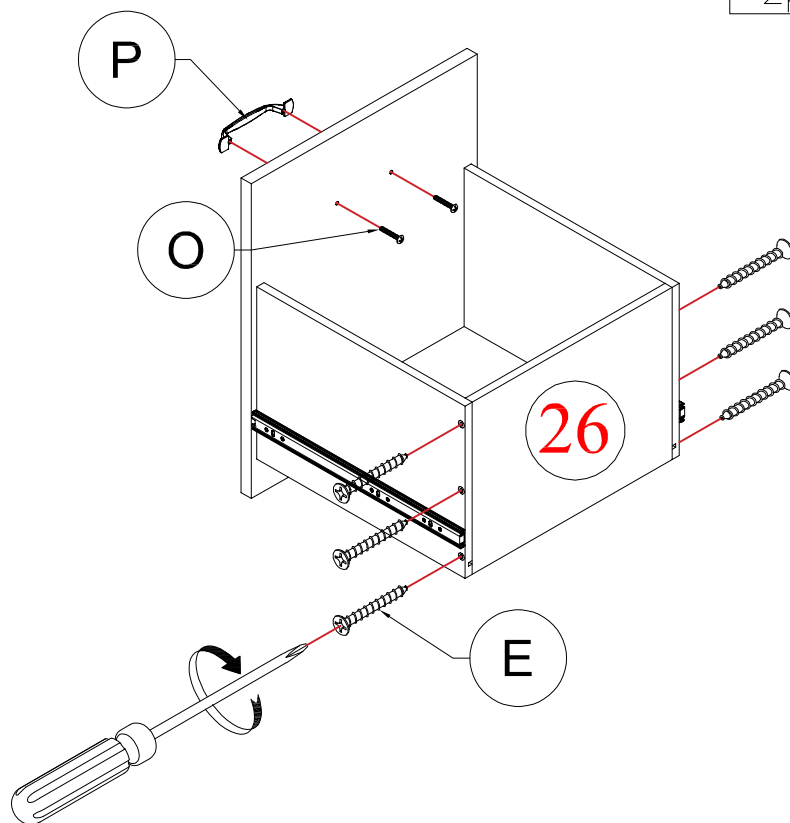

O	P	E
		
2pcs	1pc	6pcs

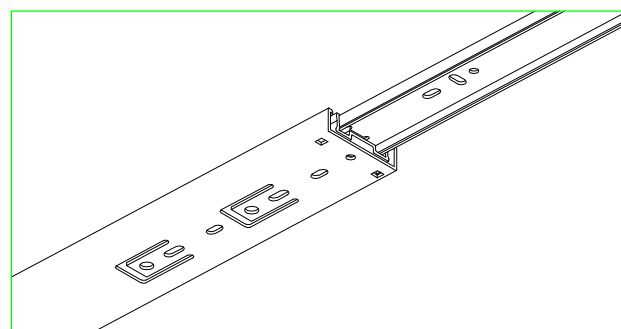
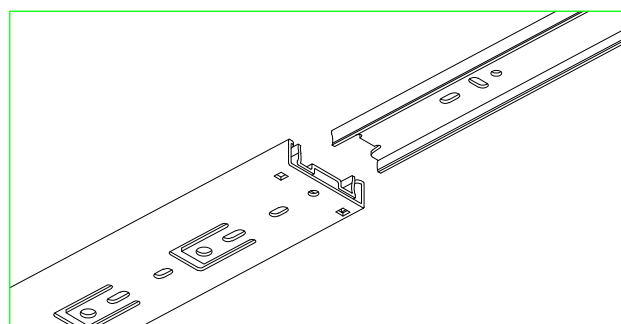
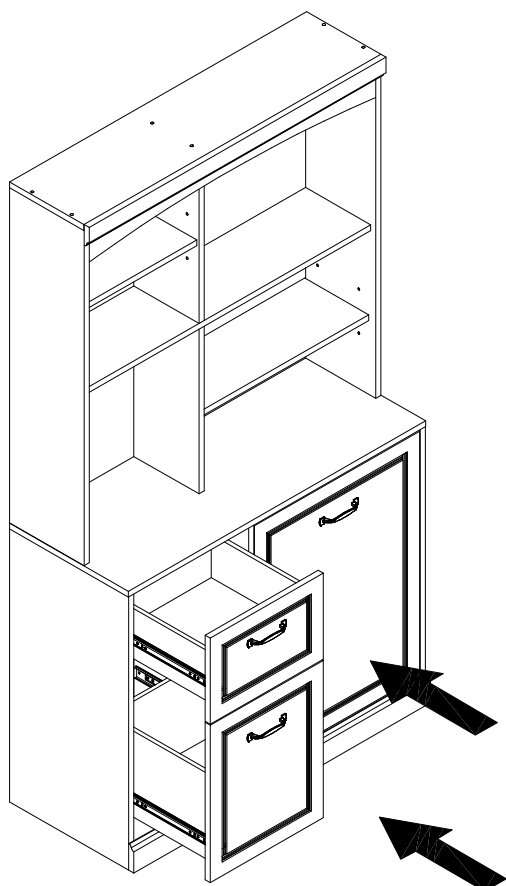

STEP 38: Following below illustration:

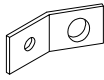

STEP 39: Following below illustration:

Q-2	Q-3	Q-4
		
2pcs	2pcs	2pcs

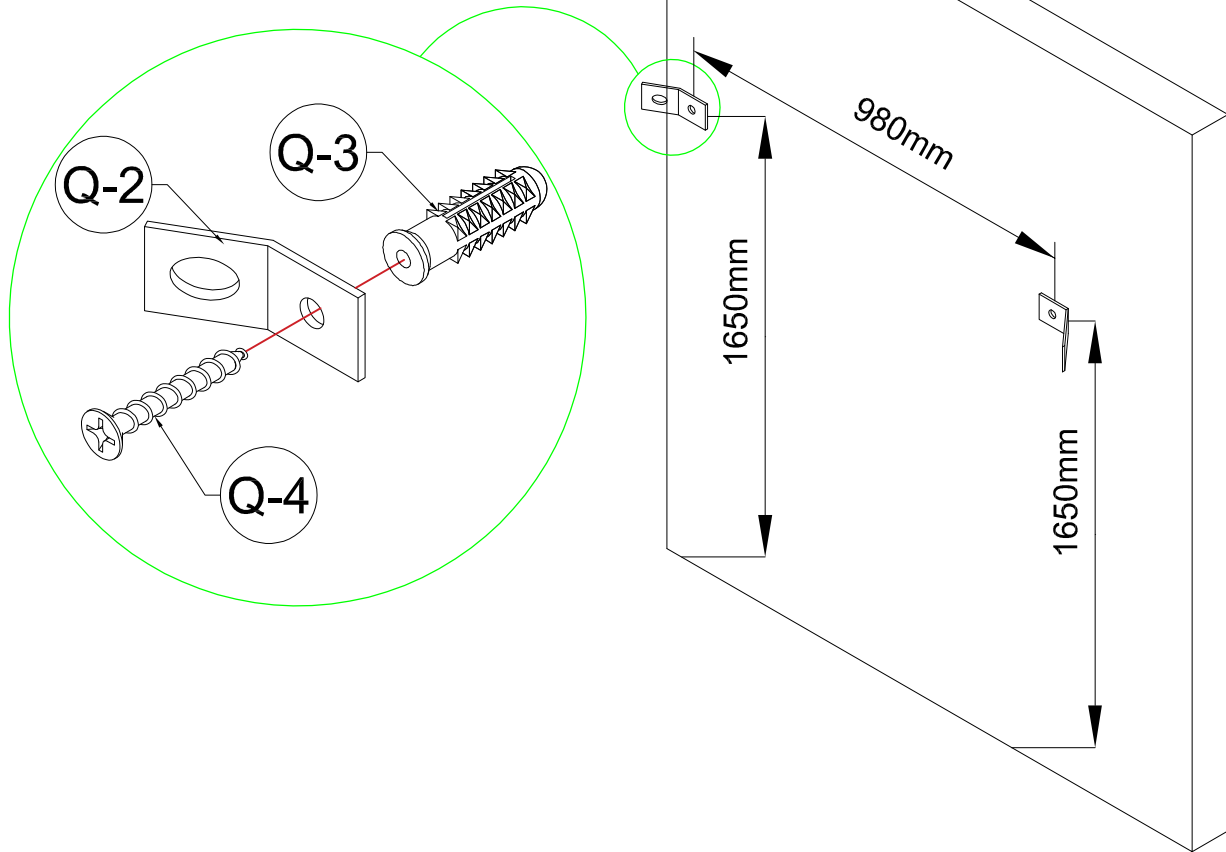

STEP 40: Following below illustration:

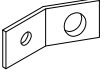
Q-5	Q-2
	
2pcs	2pcs

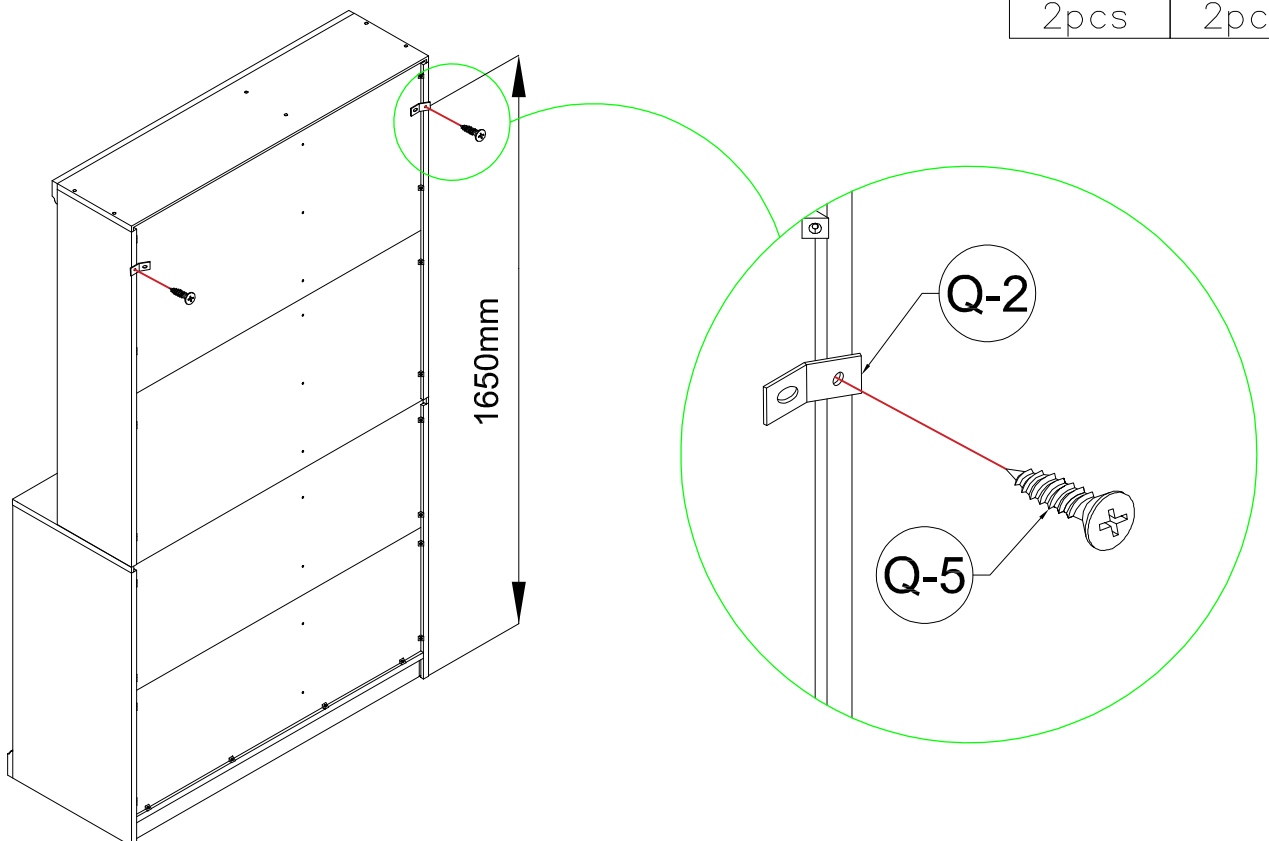

STEP 41: Following below illustration:

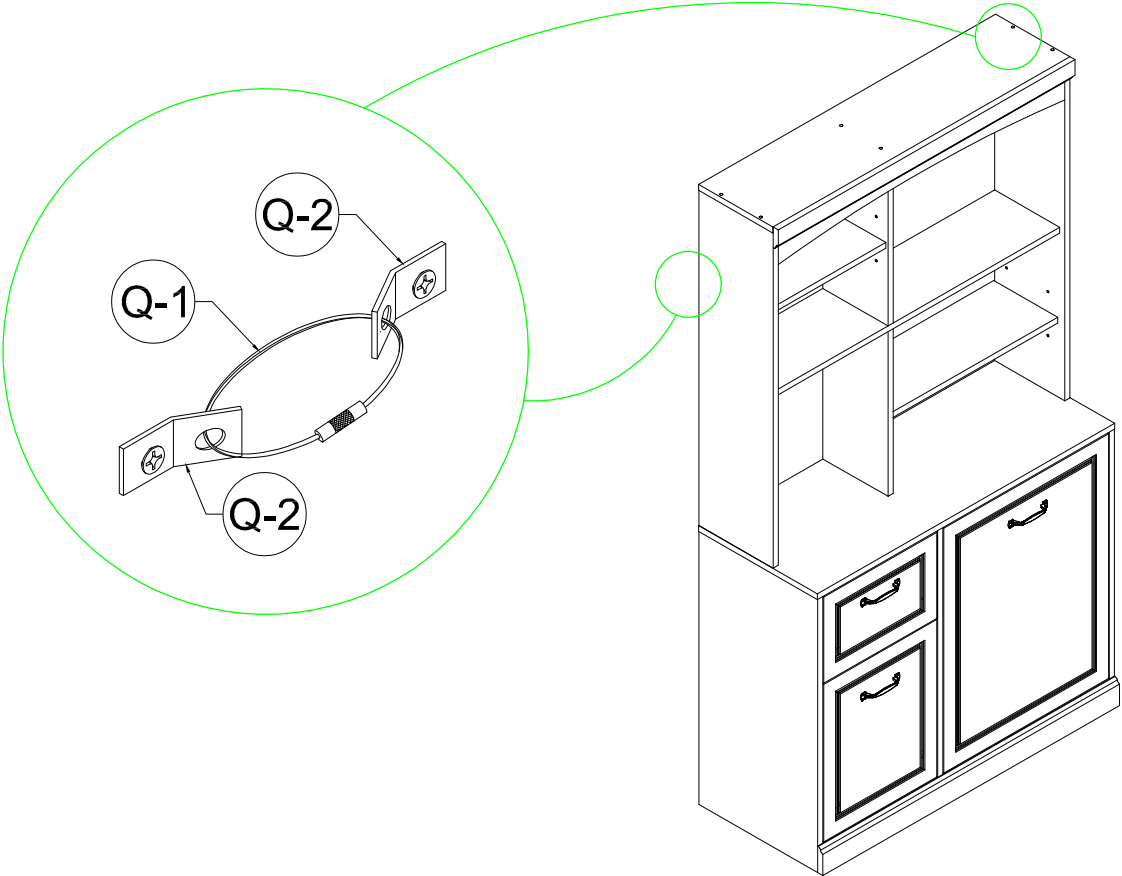

FINISH

