

ASSEMBLY INSTRUCTIONS

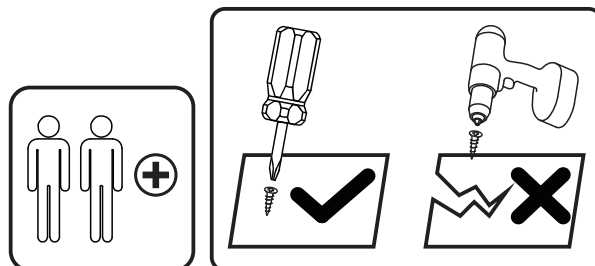
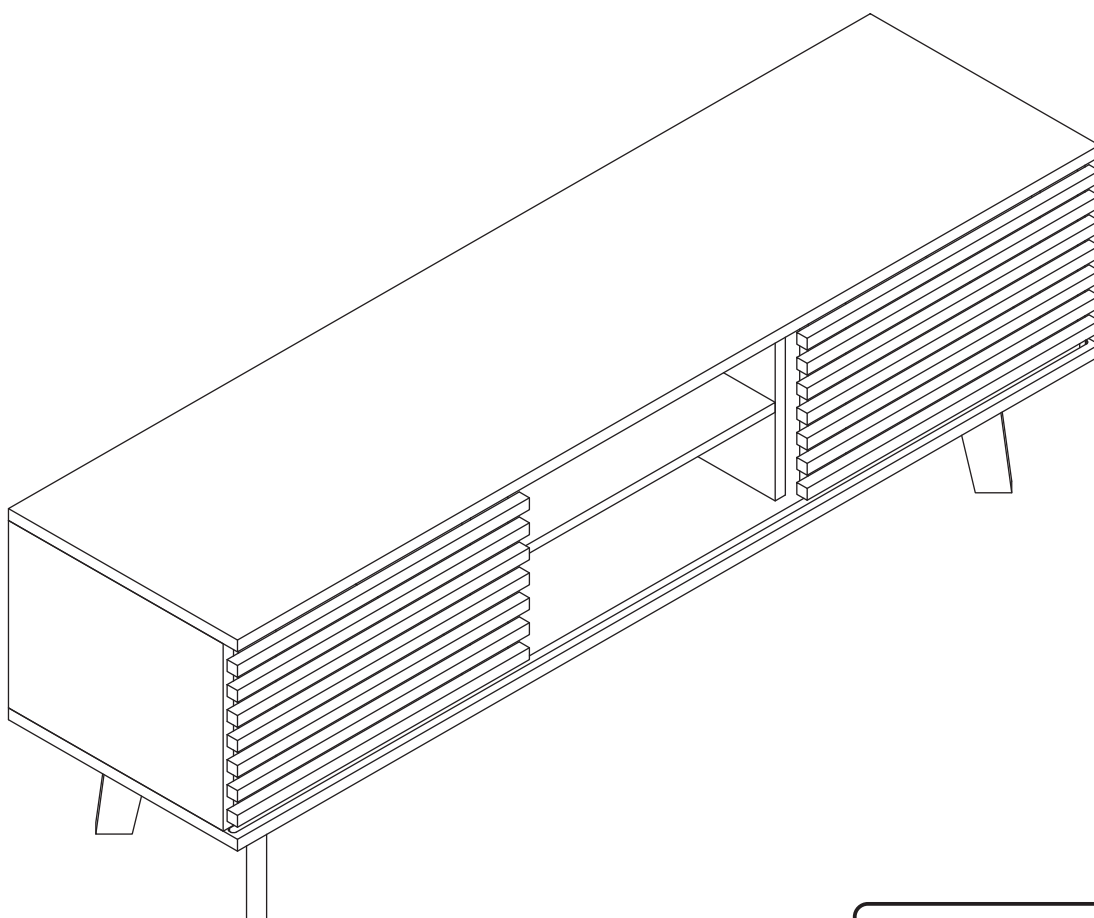

Tools Recommended

THIS INSTRUCTIONS CONTAINS IMPORTANT SAFETY INFORMATION.
PLEASE READ BEFORE ASSEMBLY AND KEEP FOR FUTURE REFERENCE.

IMPORTANT NOTICE

- This product contains small components, please ensure that they are kept away from small children.
- THIS INSTRUCTIONS CONTAINS IMPORTANT SAFETY INFORMATION.
PLEASE READ BEFORE ASSEMBLY AND KEEP FOR FUTURE REFERENCE.
- Read each step carefully. It is very important that each step of instruction is performed in the correct order. If these steps are not followed in sequence, assembly difficulties will occur.
- Make sure all parts are included. Most parts are labelled or stamped on the raw edge.
- Work in spacious area, preferably on a carpet, near the place the unit will be used.
- Do not use power tools to assemble your furniture. Power tools may strip or damage the parts.
- Move your new furniture carefully, with two people lift and carry the unit to it's new location.
- Never push, drag or pull your furniture (especially on carpet)



PLEASE DO NOT RETURN PRODUCT TO US IMMEDIATELY

If a part is missing or damaged, email our customer service.
We will gladly ship your replacement parts FREE of charge.

Need Parts or Assistance?

For Prompt, reliable service, please have your assemble instruction ready.

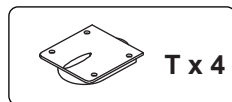
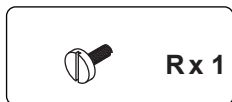
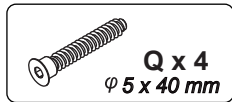
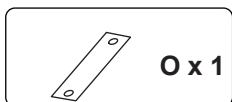
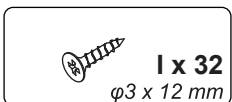
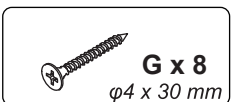
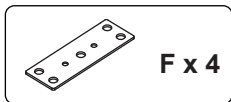
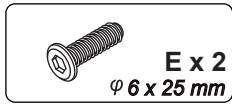
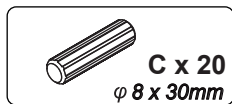
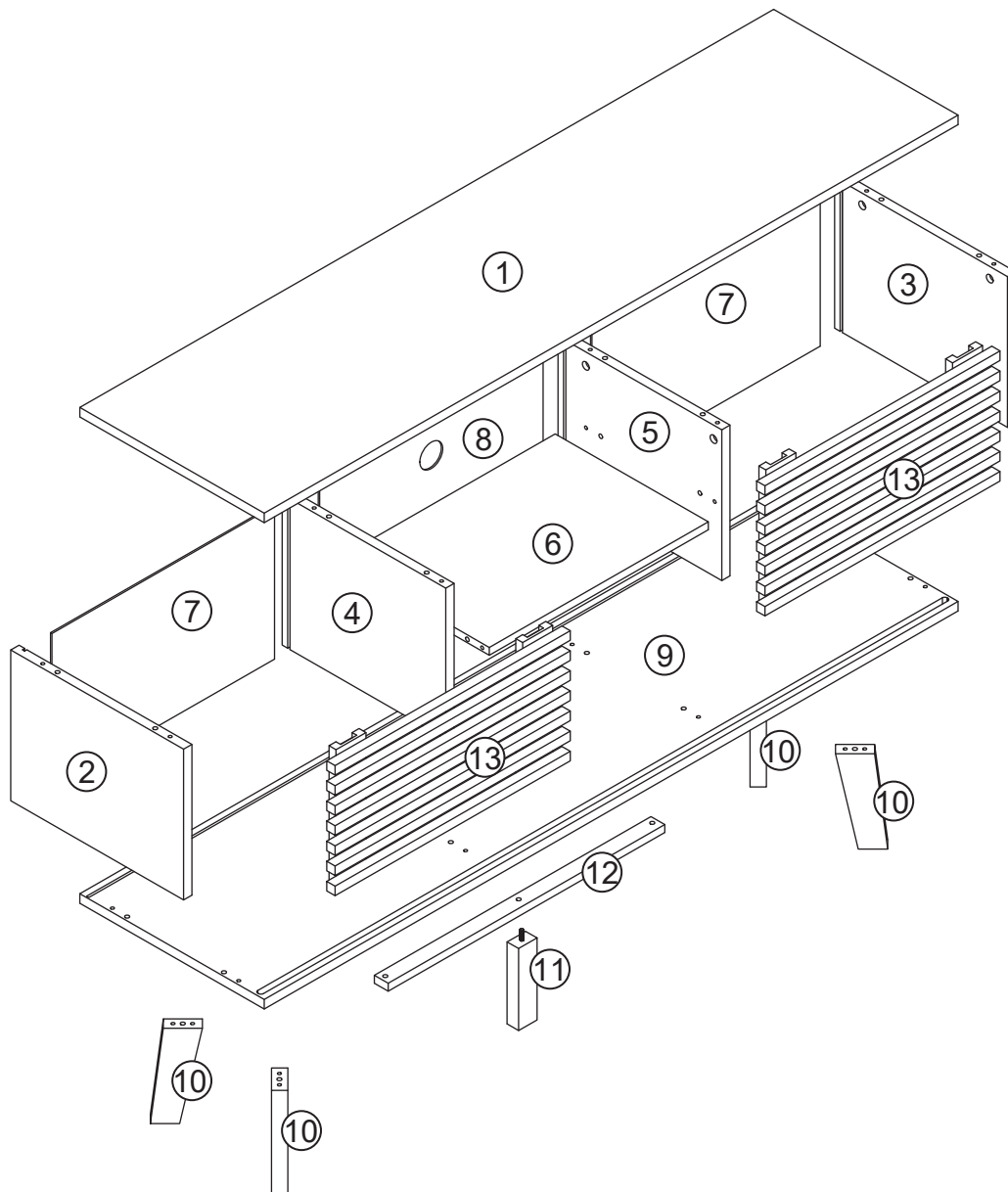

Step 1

Insert quickfit screws(A) into corresponding holes in part 1, as shown.

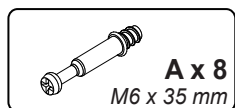
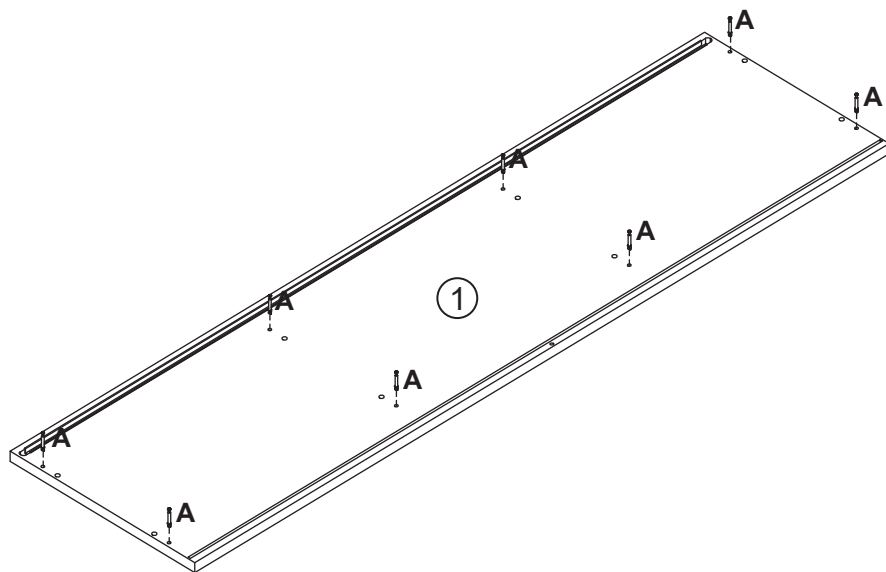

Step 2

Insert quickfit screws(A) into corresponding holes in part 4 & 5, as shown.

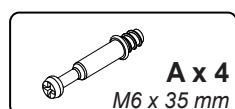
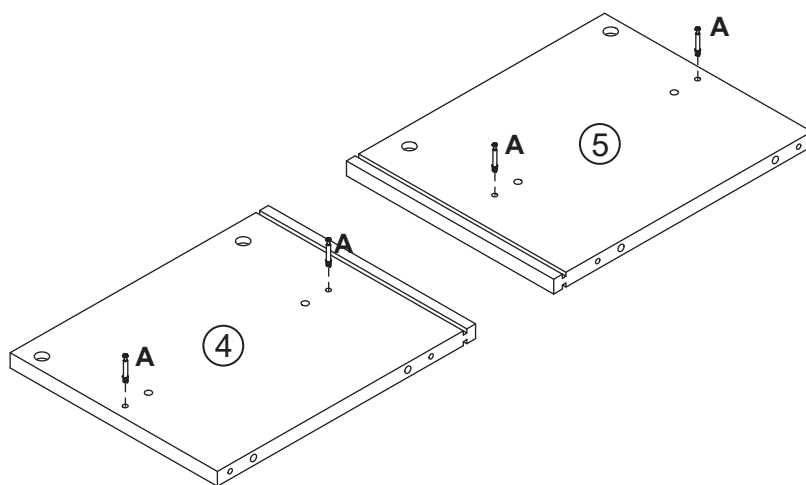

Step 3

Connect panel 4 & 5 to panel 6 with wooden dowels (C), then add cam locks (B) into assembled unit and turn cam locks clockwise to tighten as shown.

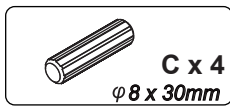
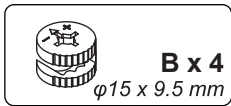
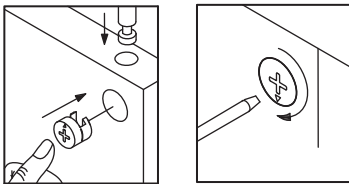
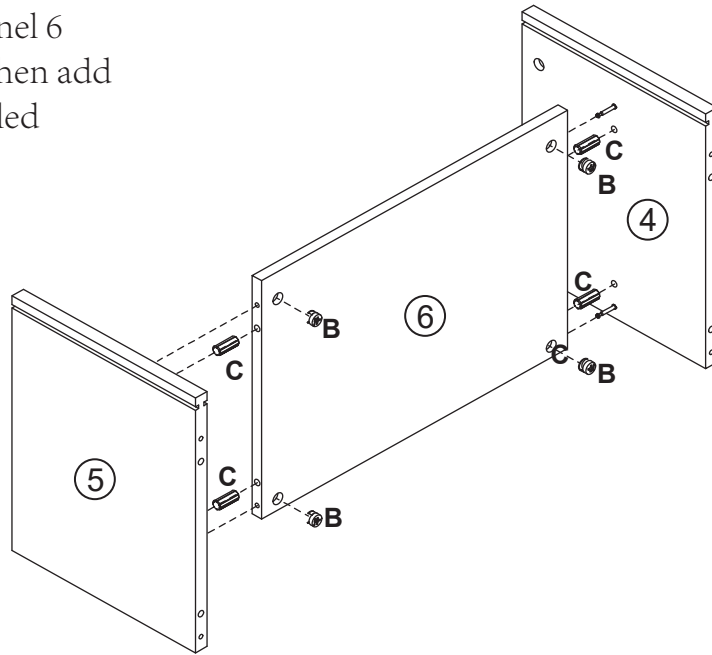

Step 4

Connect panel 4 & 5 to panel 9 with wooden dowels (C), and fix them with screw D, as shown.

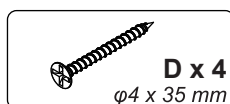
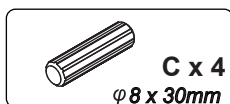
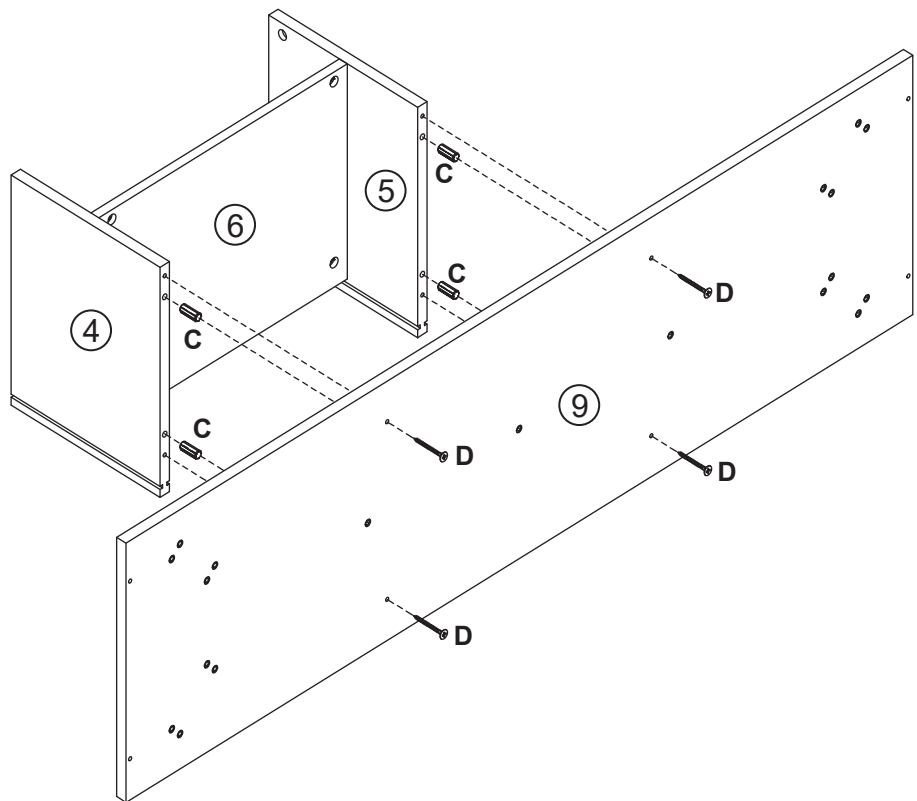

Step 5

Connect panel 2&3 to panel 9 with wooden dowels C, and fix them with screw D, as shown.

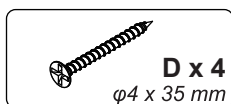
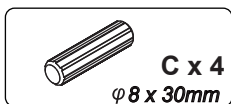
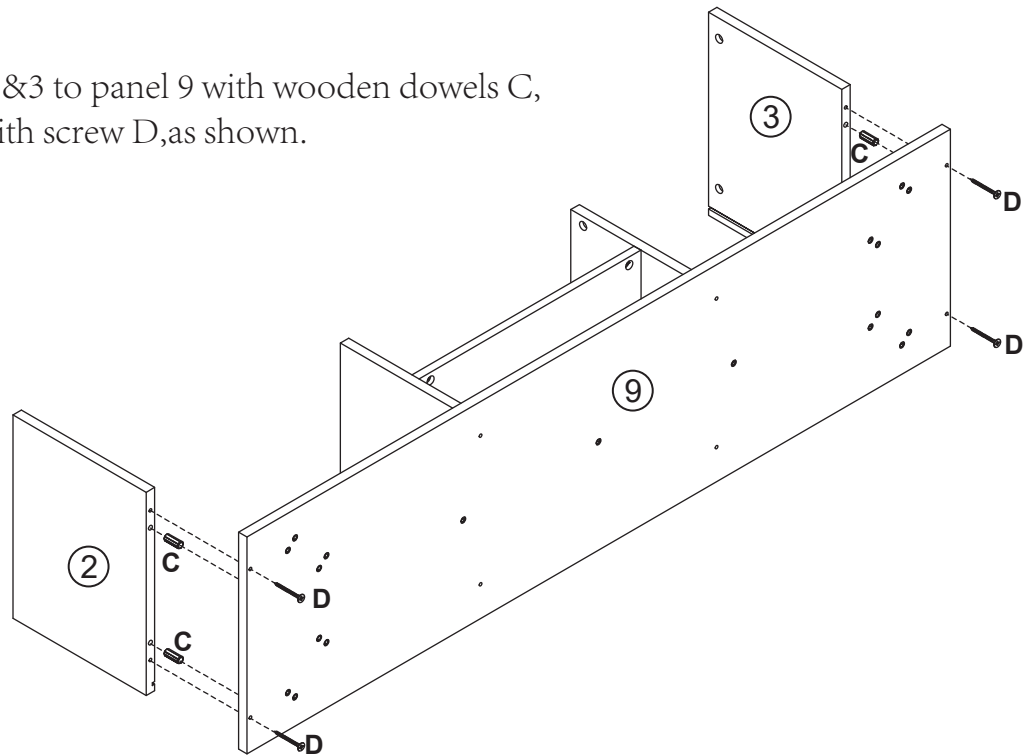

Step 6

Fix panel 12 to panel 9 with screw E and turn screw E to tighten with spanner H, then install the support leg 11 to part 12. Please remember to install the adjustable screw (R) to the leg, as shown.

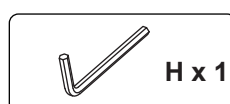
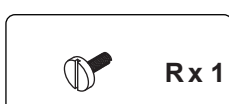
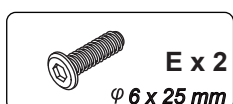
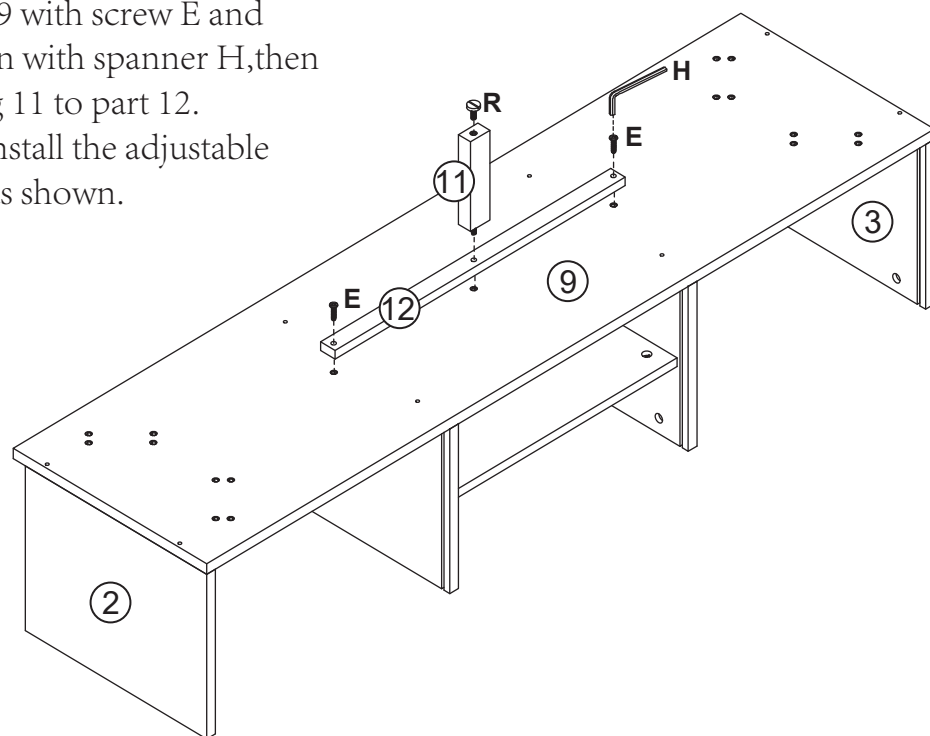

Step 7

First, attach part (F) to part 10 using screws (Q) & (G). Screw (Q) for the middle hole and Screw (G) for the side holes.

Then, install the assembled legs to part 9 using screws (P) and allen wrench (H).

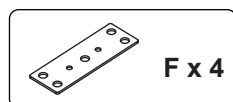
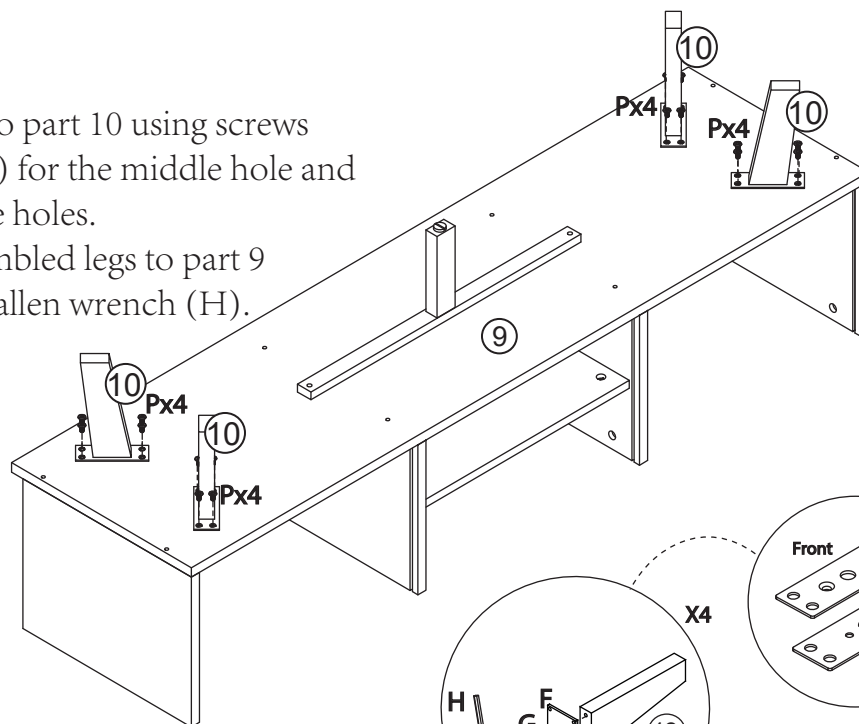

F x 4



G x 8
φ4 x 30 mm



H x 1



P x 16
φ6 x 12 mm

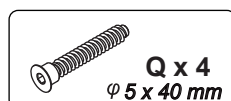

Q x 4
φ5 x 40 mm

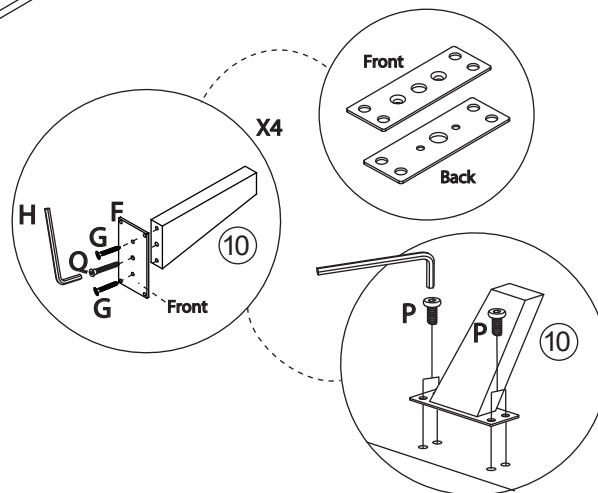

Step 8

Sliding the back panels part 7 and part 8 into the available slots of the assembled unit, as shown.

Part 8 should be in the middle.

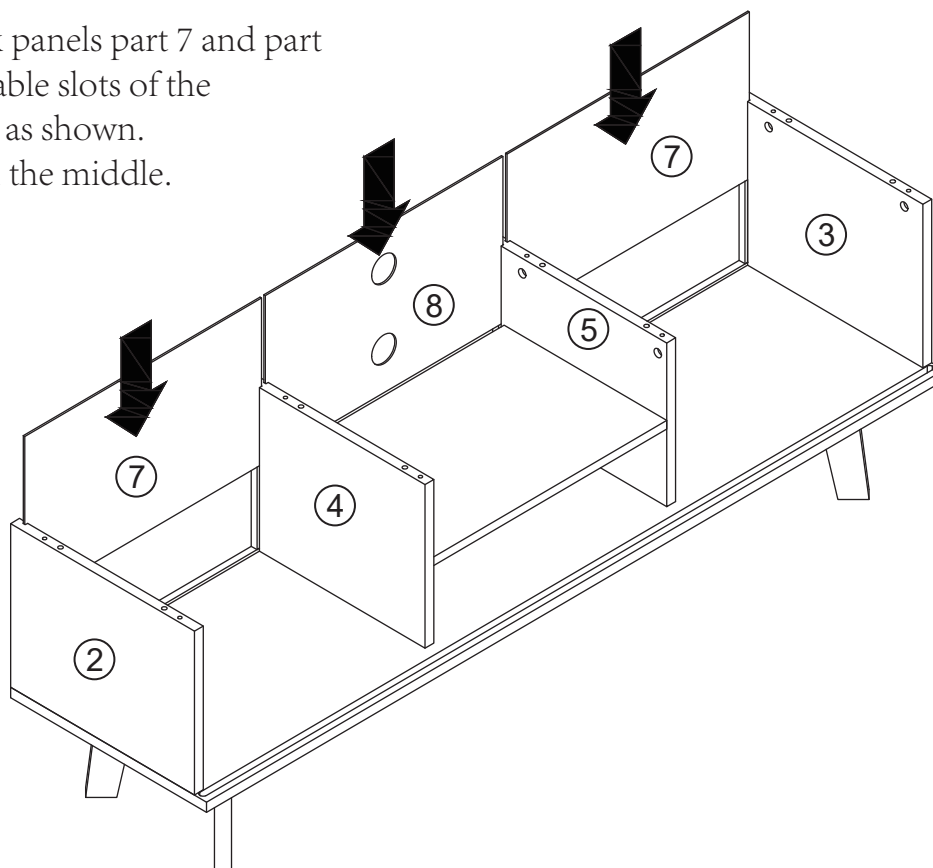

Step 9

Insert wooden dowels (C) into part 2, 3, 4, 5. Then attach part 1 to assembled unit, Add cam locks (B) into assembled unit as shown.

Turn cam locks clockwise to tighten.

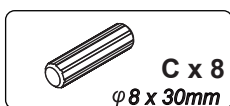
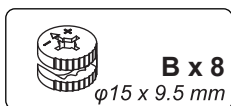
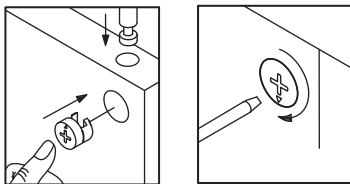
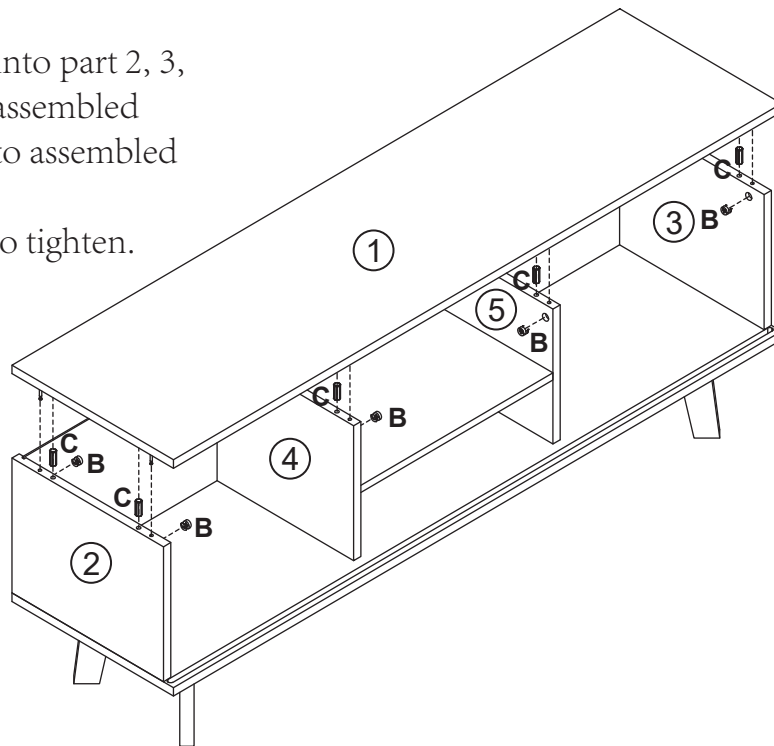

Step 10

Fix part (J) to the back corners of the assembled unit using screws (K), as shown.

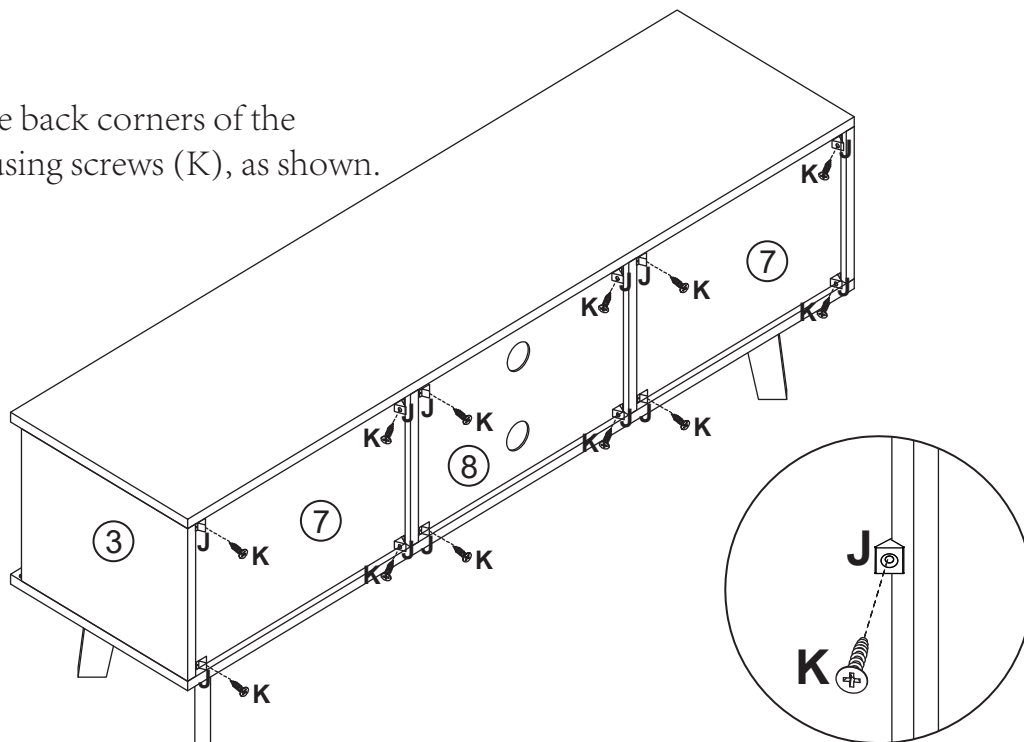

Step 11

Fix the sliding door wheel(S & T) to panel(13) using screw(I),as shown.

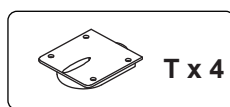
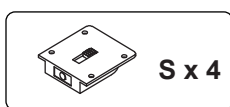
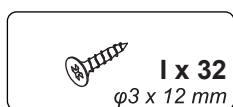
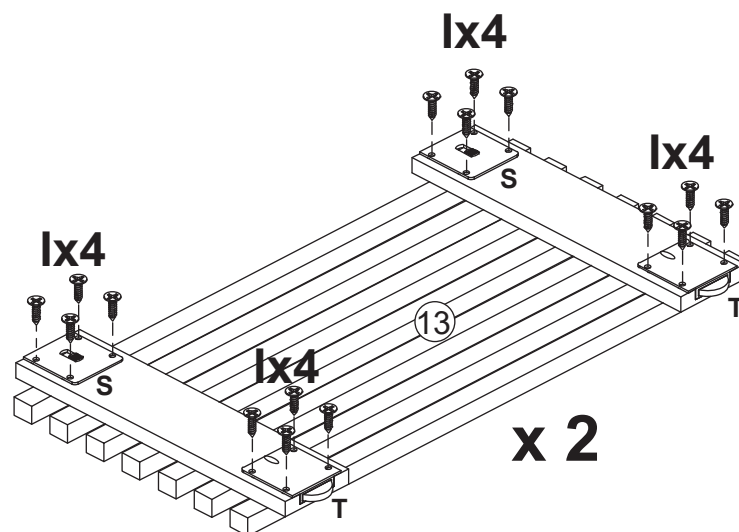

Step 12

Place the door (13) into the assembled unit,as shown.

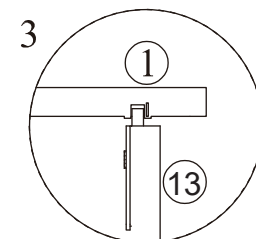
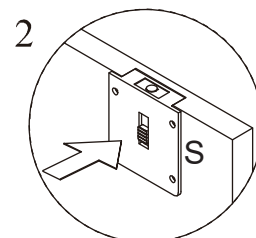
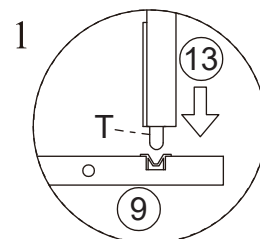
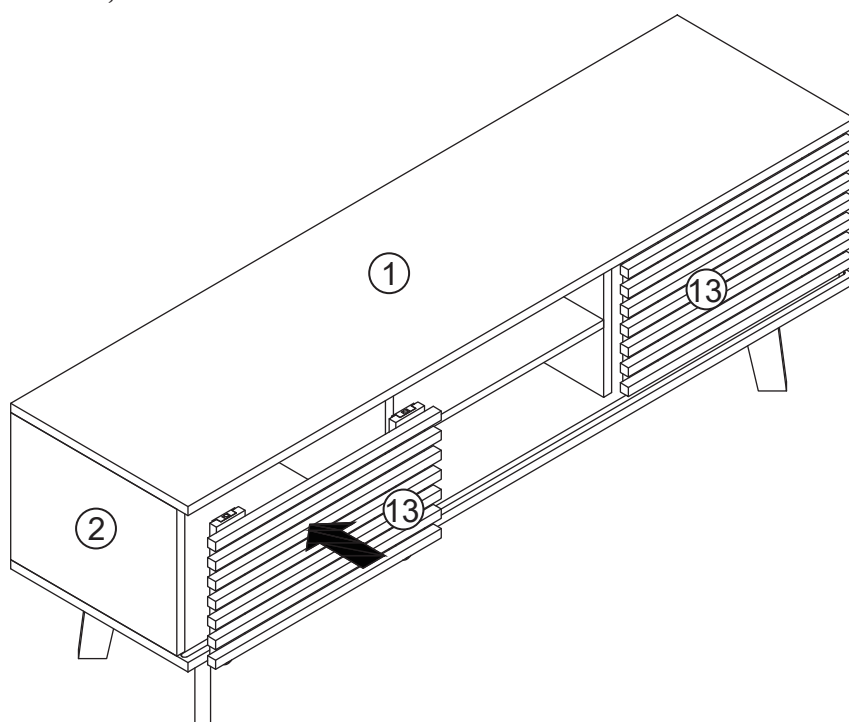

Step 13

Install anti-tipping device as shown.

