

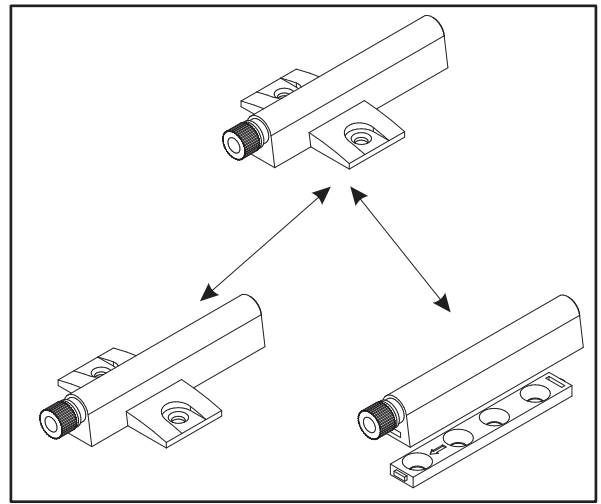

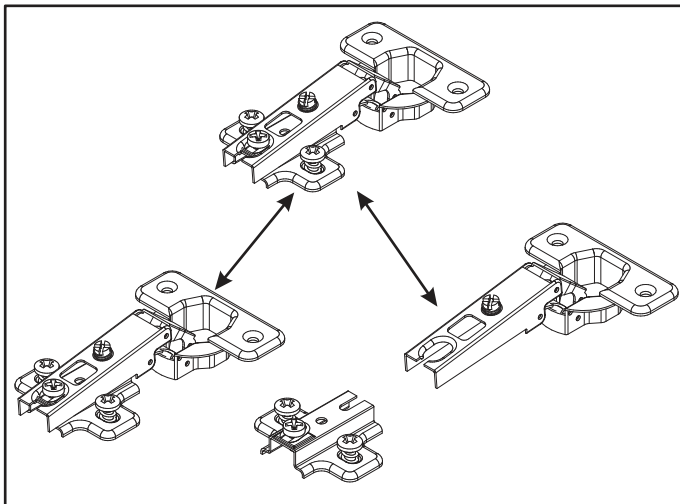

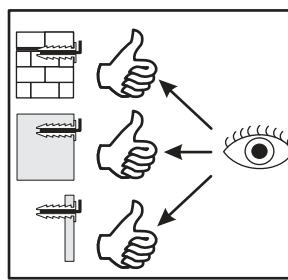

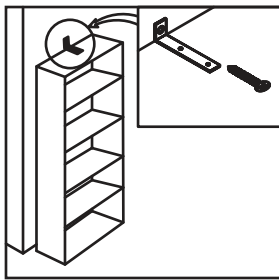

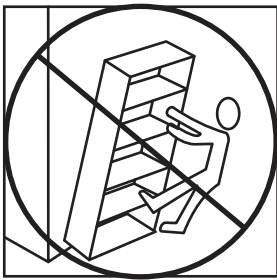
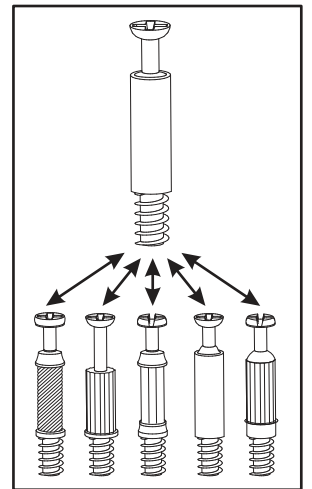
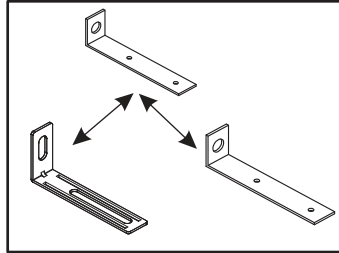
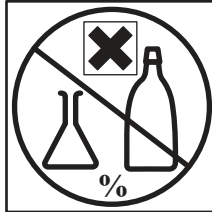
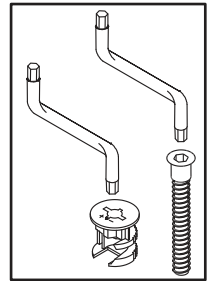
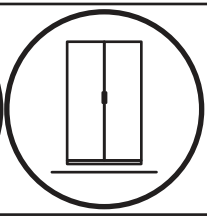
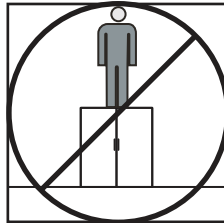
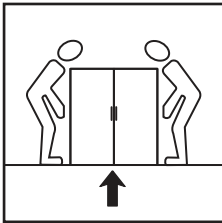
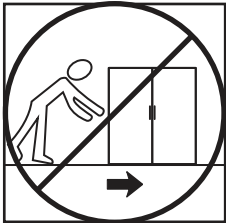
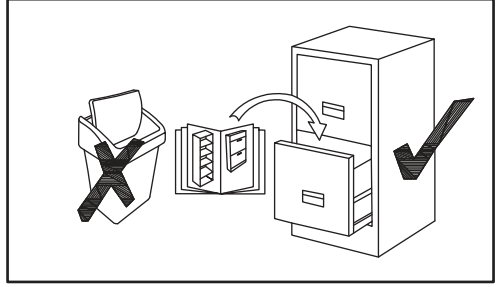
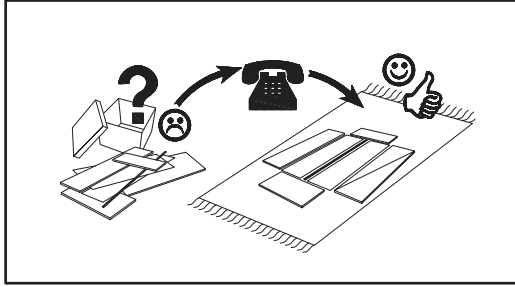
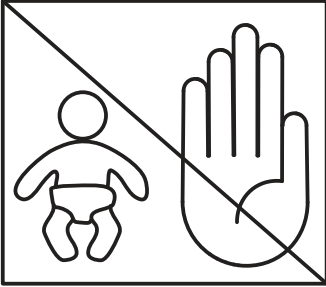
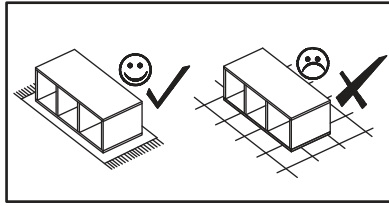
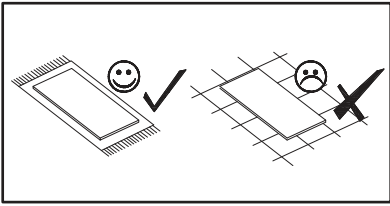
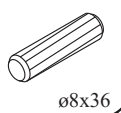
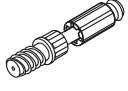

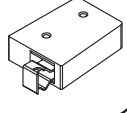

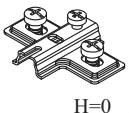
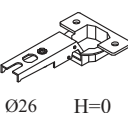

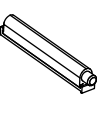
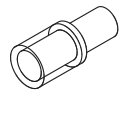
NO	Dim.			Col.-No	Qt
1	1228	274	16	1	1
2	1228	274	16	1	1
3	400	274	16	1	2
4	364	234	5	1	2
105	1240	378	3	1	1
106	394	410	16	1	1
206	394	410	16	1	1
7	485	362	4	1	1

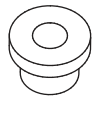
NO	Dim.			Col.-No	Qty
1	48 11/32	10 25/32	5/8	1	1
2	48 11/32	10 25/32	5/8	1	1
3	15 3/4	10 25/32	5/8	1	2
4	14 21/64	9 7/32	13/64	1	2
105	48 13/16	14 7/8	1/8	1	1
106	15 33/64	16 9/64	5/8	1	1
206	15 33/64	16 9/64	5/8	1	1
7	19 3/32	14 1/4	5/32	1	1

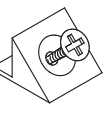

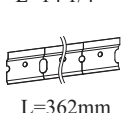
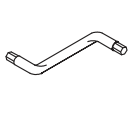
FLY 28--FY 22-C

A1 x8  Ø5/16"x1 27/64" ø8x36	B4 x8 	B5 x8  Ø19/32"x15/32" ø15x12	G5 x8 	ZR1 x2 	D6 x4  USØ9/64"x1 3/16" USØ3,5x30
E2 x4  H=0	E1 x4  Ø1 1/32" Ø26 H=0	D10 x10  USØ9/64"x33/64" USØ3,5x13	AM x1 	G20 x8 	Z2 x8  Ø13/64" Ø5
P2 x6 	UP13 x10  UPØ1/8"x5/8" UPØ3x16	S1 x10 	KR5 SFXP x2  Ø 25/64"/1 31/32" x2 23/64" Ø10/50x60	SZ9 x1  L=14 1/4" L=362mm	G2 x1 
LZ3 x1 	LED x2 				

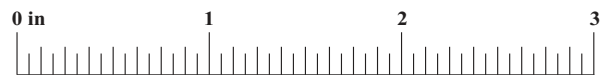
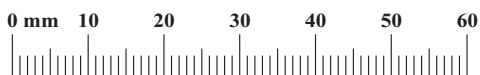
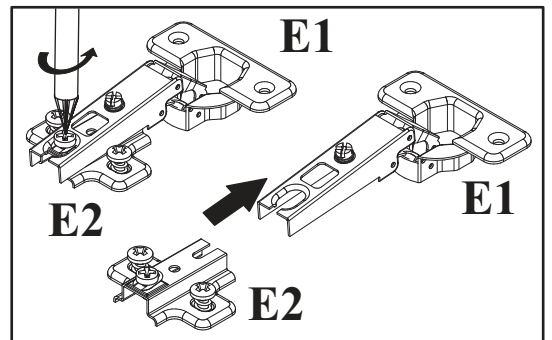

A1	Ø5/16"x1 27/64"
x8	 ø8x36

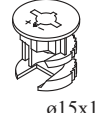
B5	Ø19/32"x15/32"
x8	 ø15x12

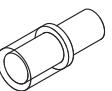
G20	
x8	

1

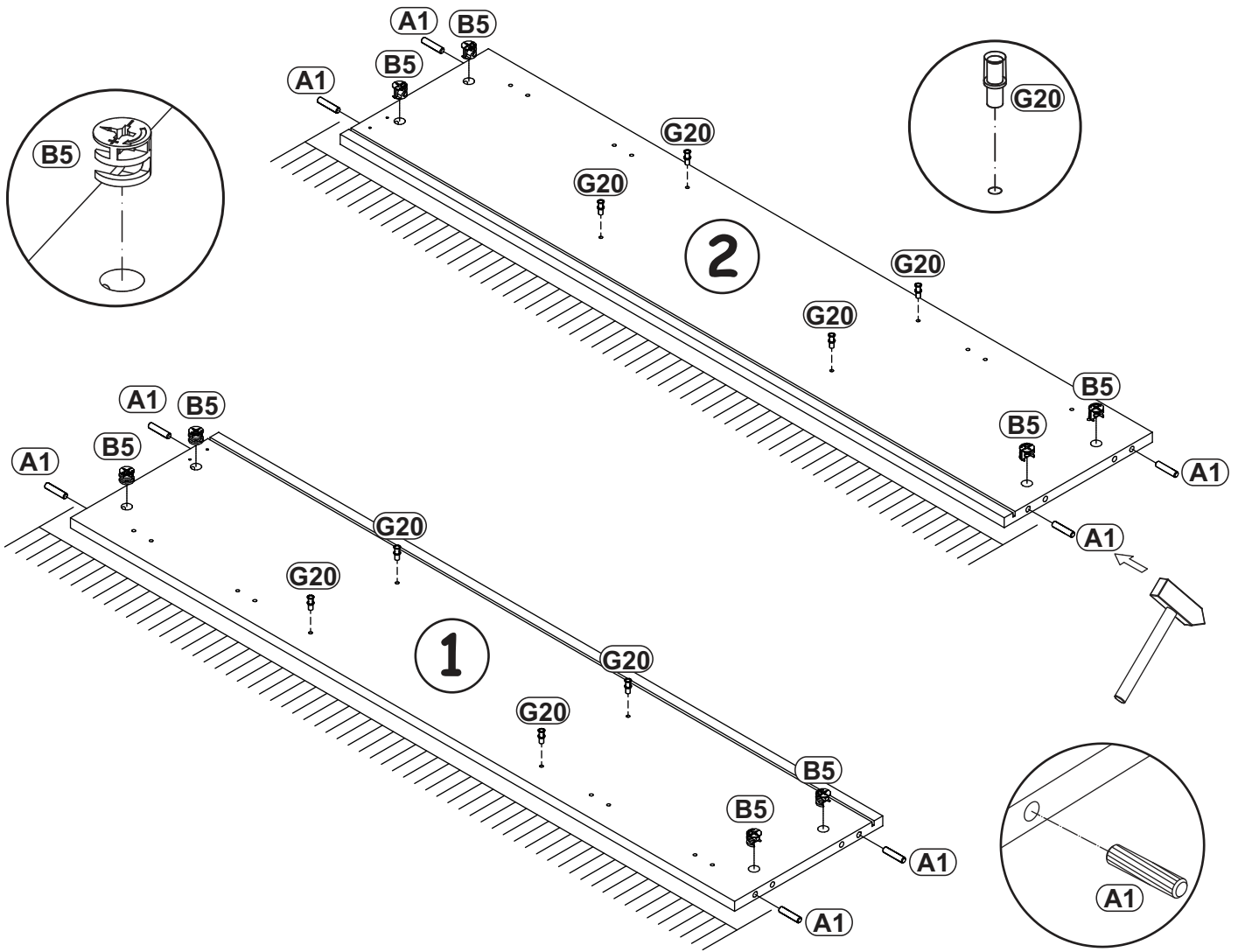

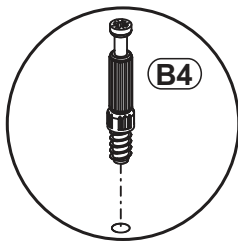

2

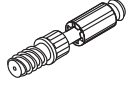

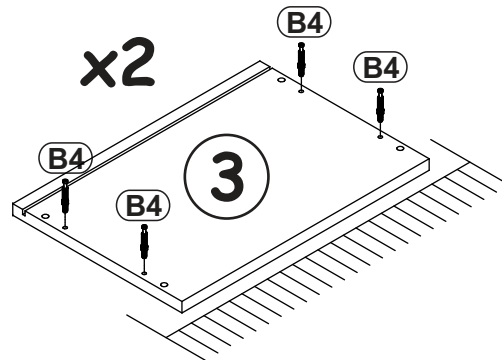
B4	
x8	

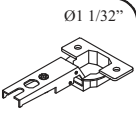
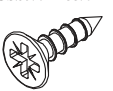
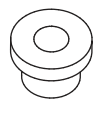

3

E1	 Ø1 1/32"	D10	 US09/64"x33/64"
x4	Ø26 H=0	x8	USØ3,5x13
P2		UP13	 UPØ1/8"x5/8"
x6		x6	UPØ3x16

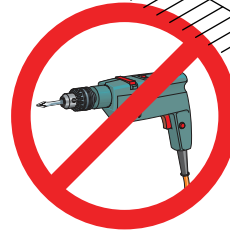
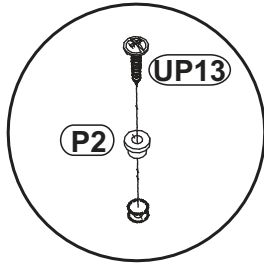
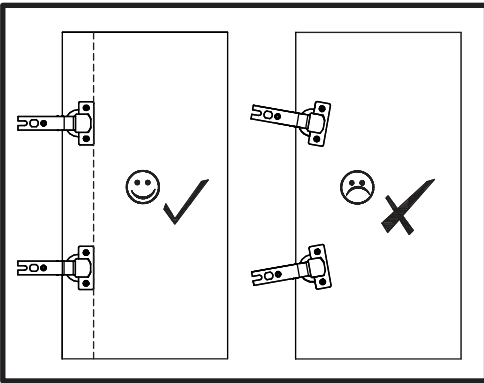
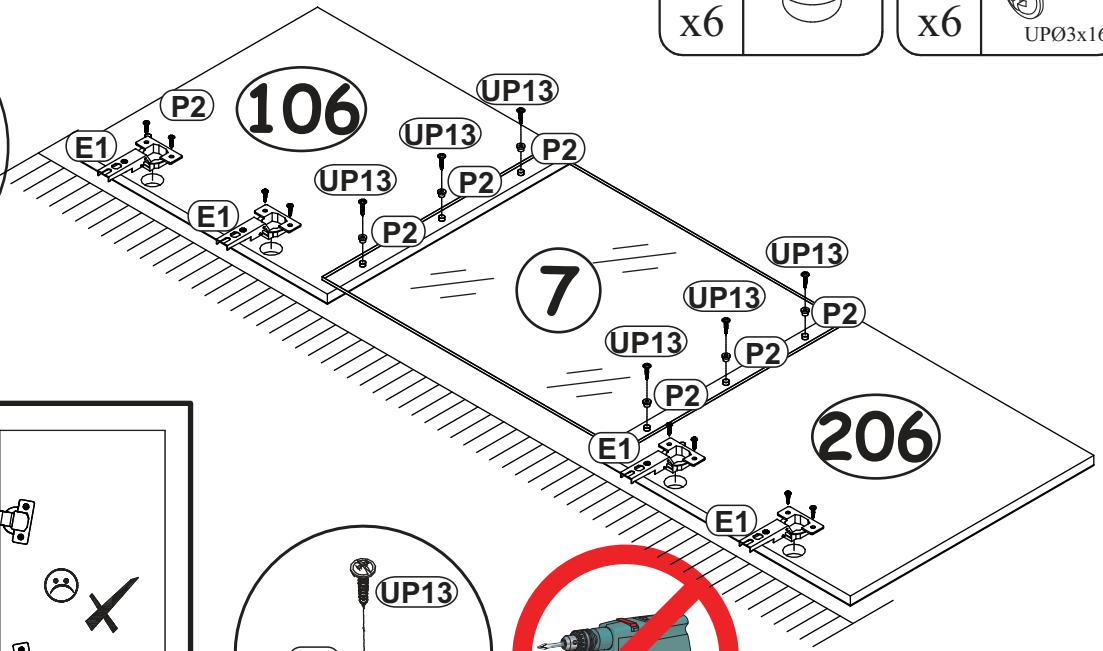
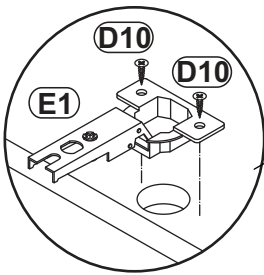

4

G5	
x4	

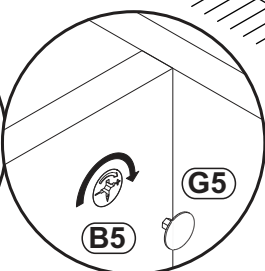
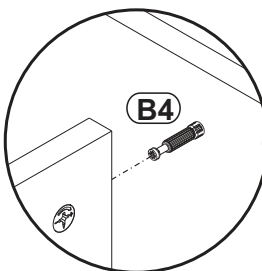
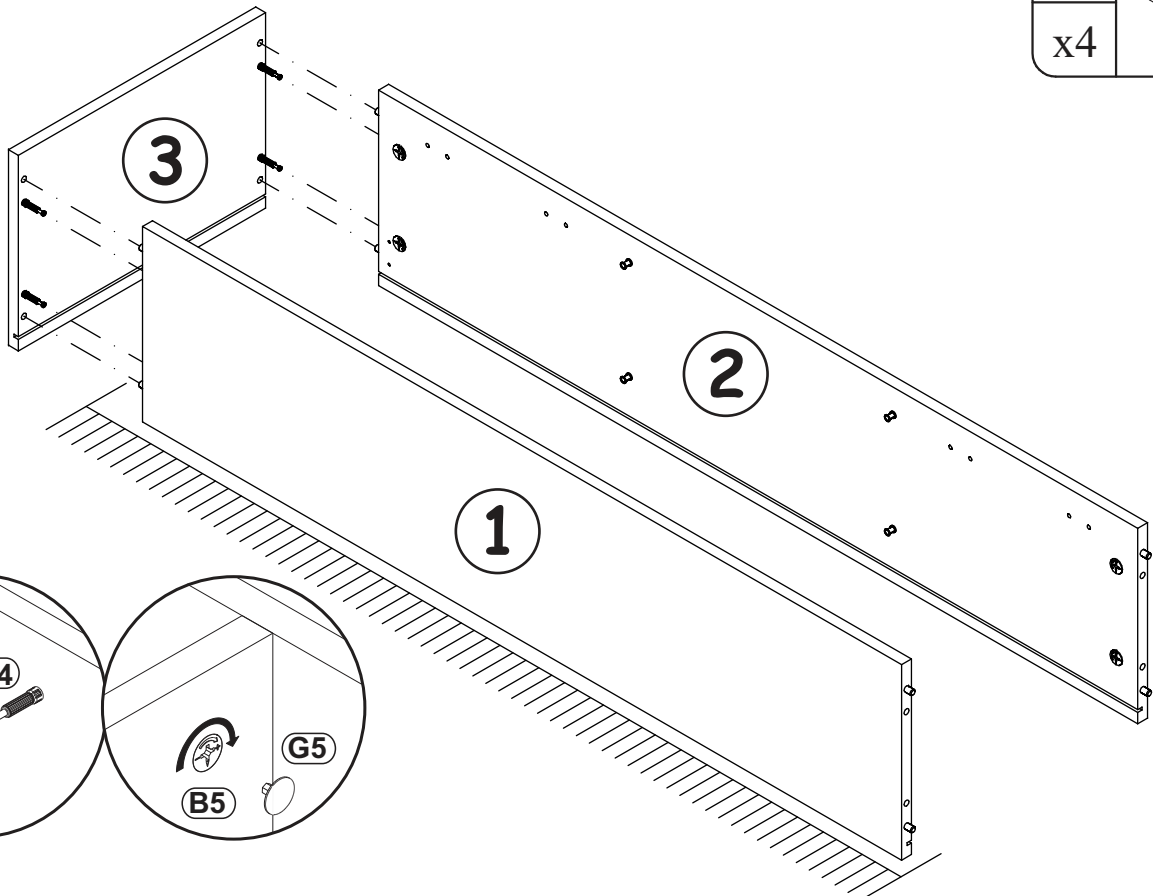

G5	
x4	

5

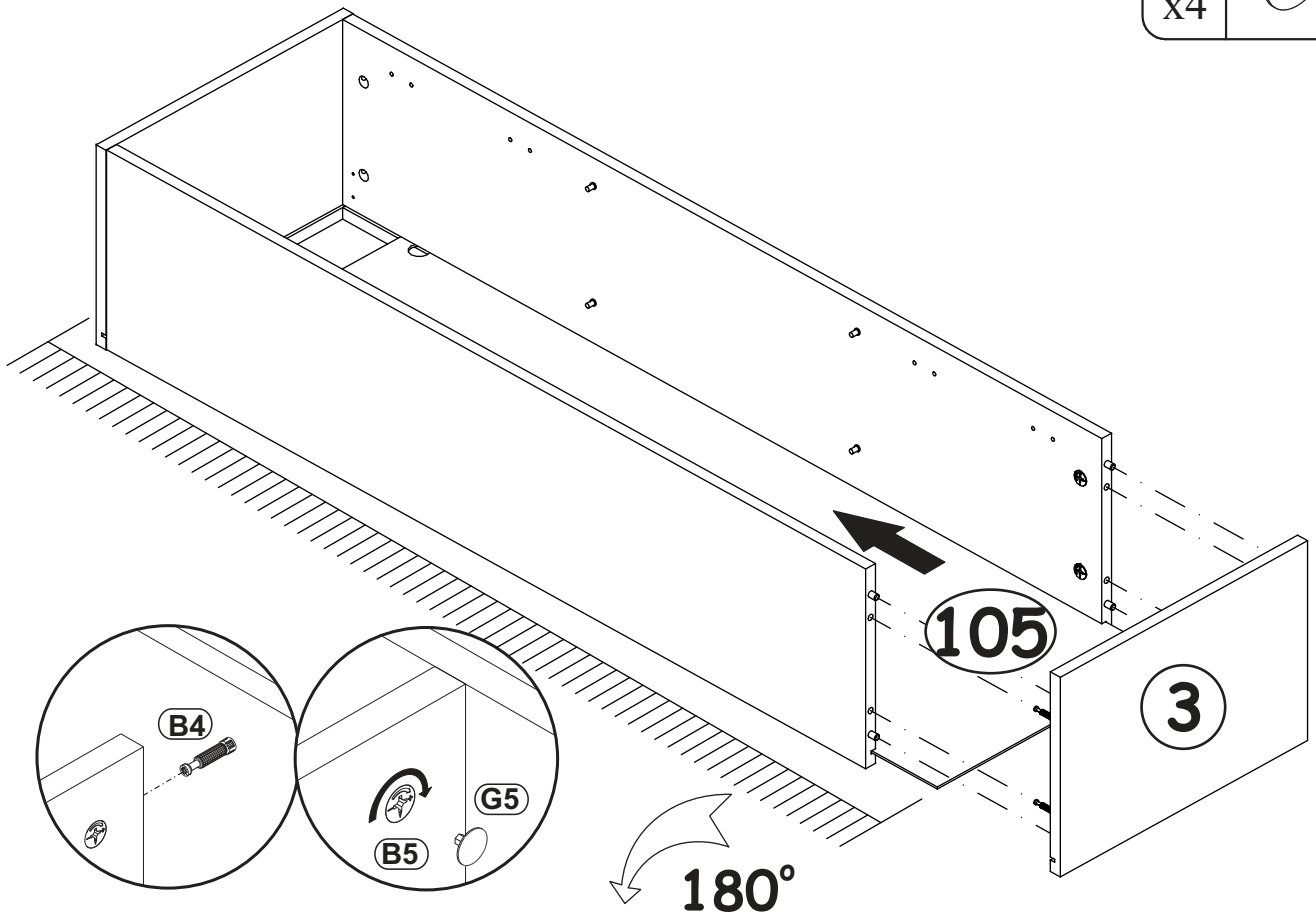

6



S1	
x10	

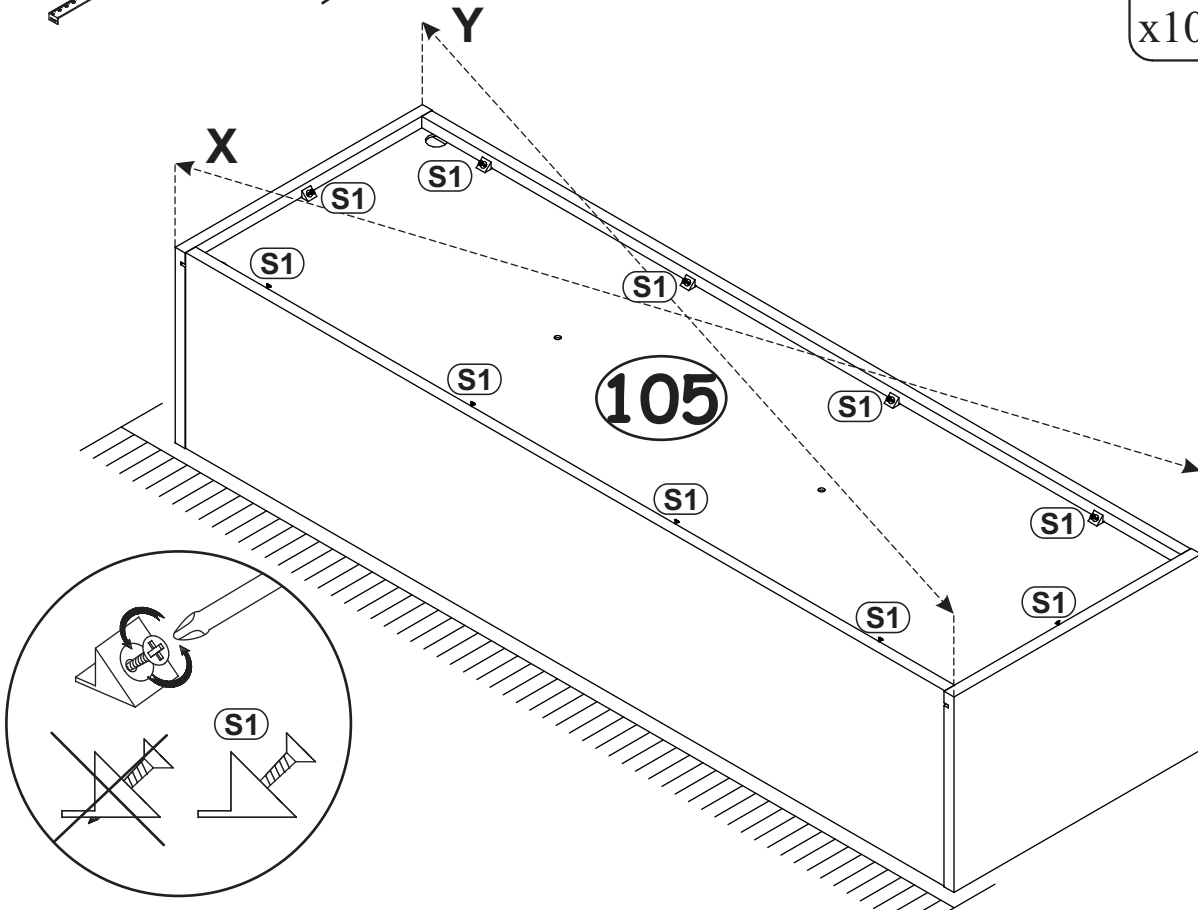

FLY 28--FY 22-C

7

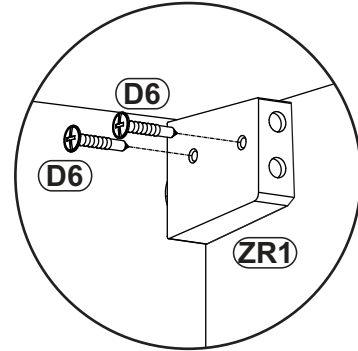
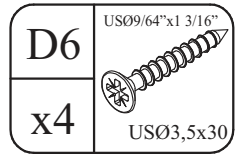
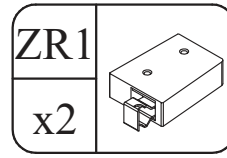
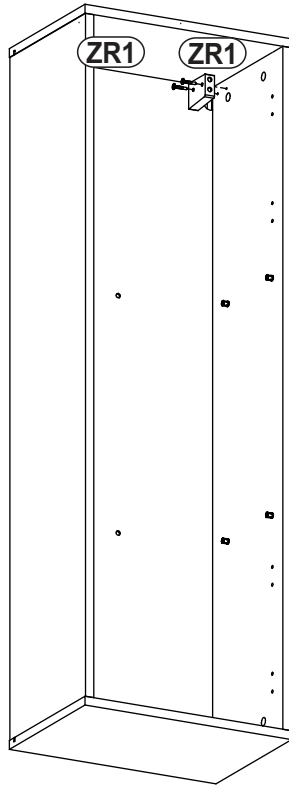
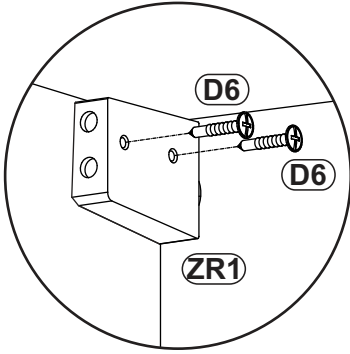

8

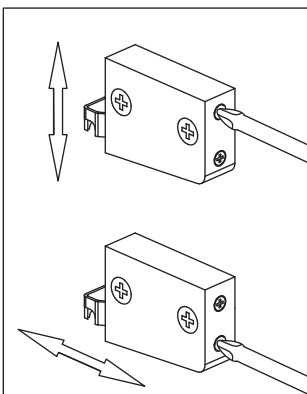
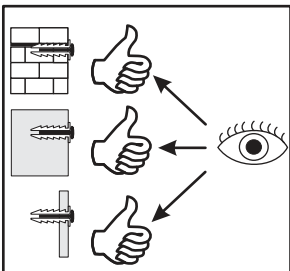
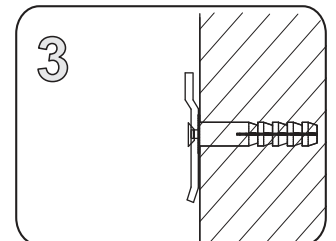
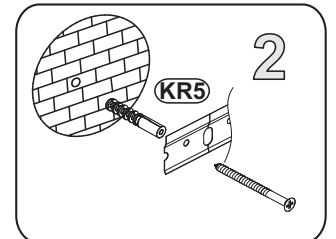
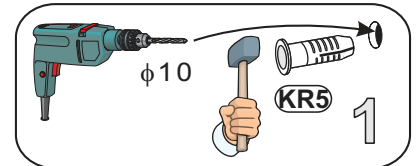
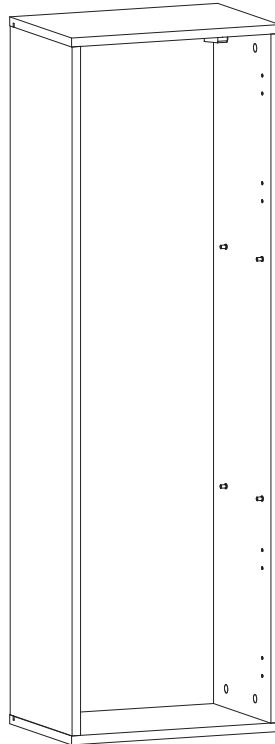
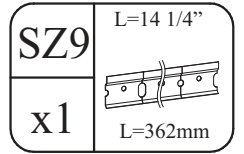
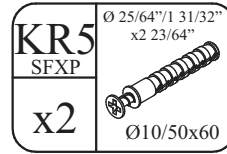
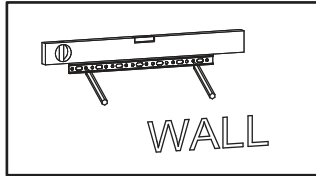
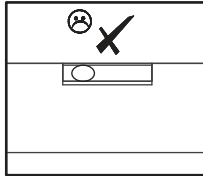
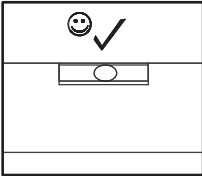

9-11

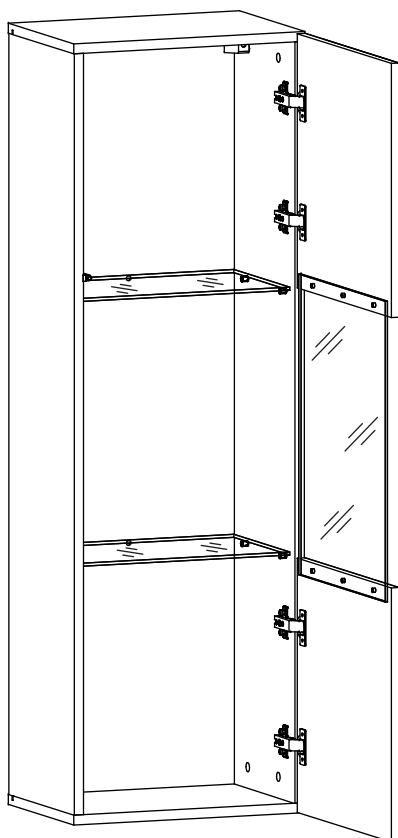

12-14

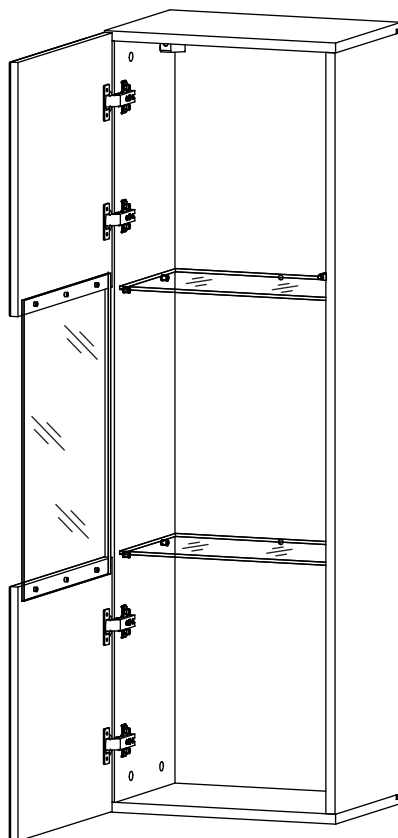

9

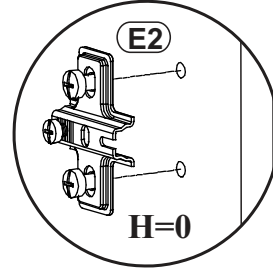
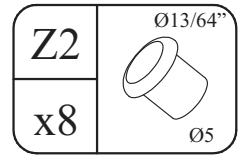
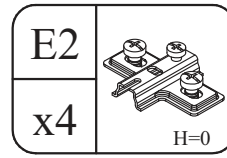
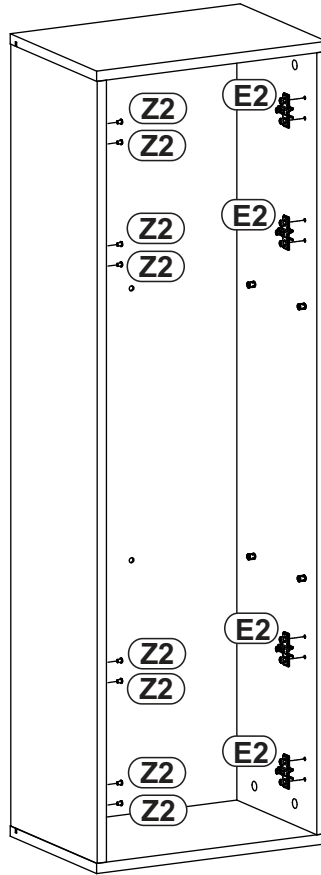
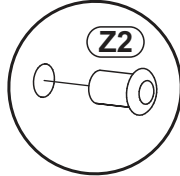
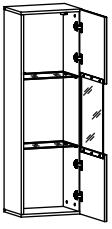

10

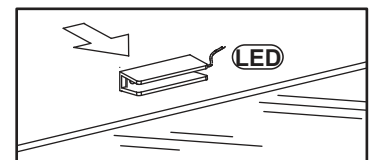
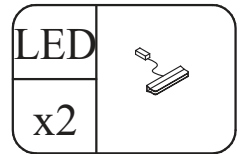
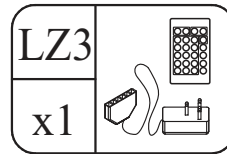
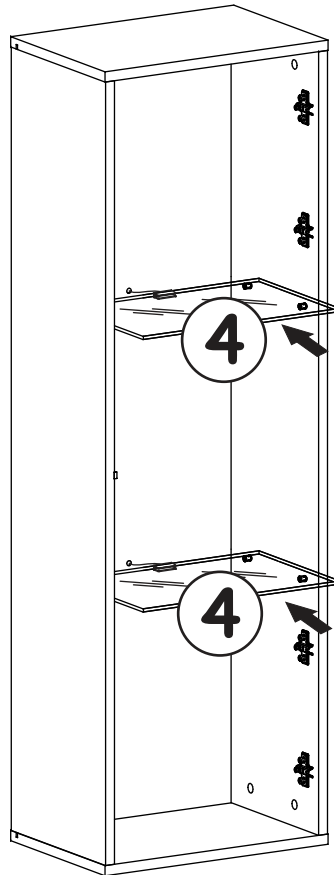
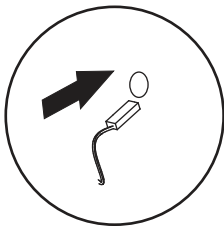
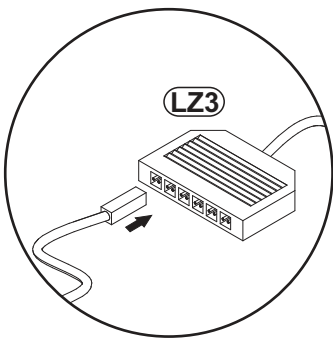
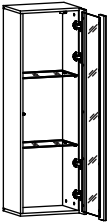

FLY 28--FY 22-C

11

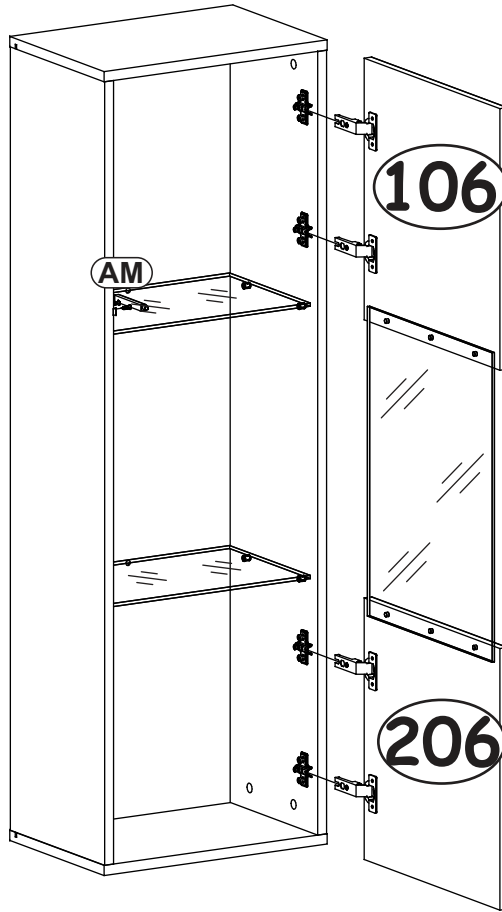
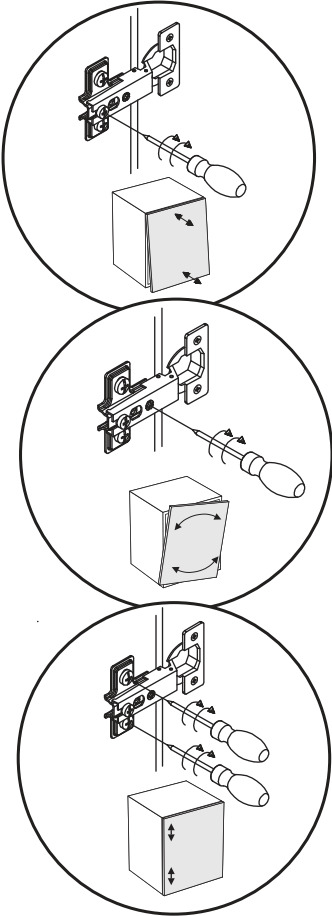

AM	
x1	

D10	US09/64"x33/64"
x2	
	USØ3,5x13

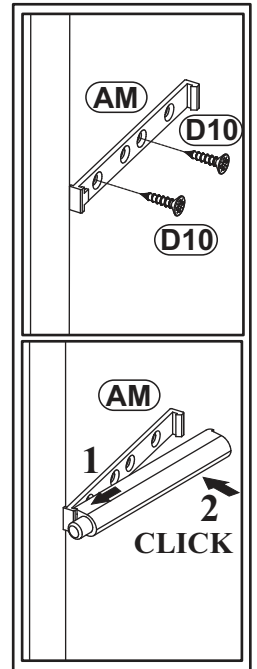

12

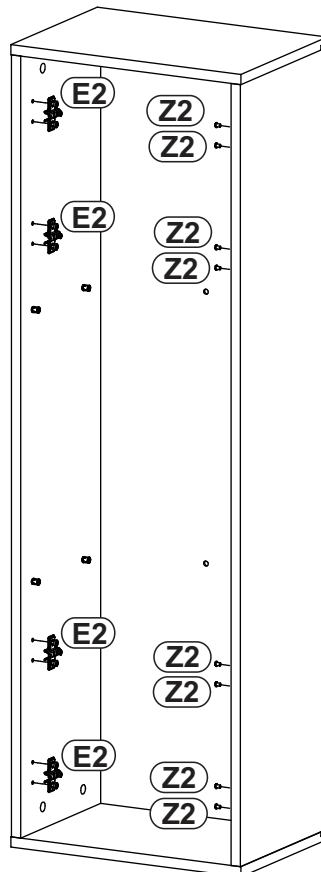
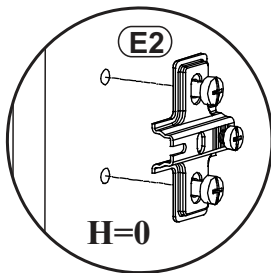
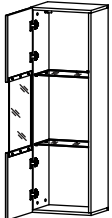

E2	
x4	H=0

Z2	Ø13/64"
x8	
	Ø5

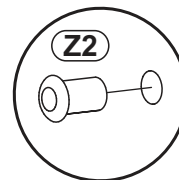

11

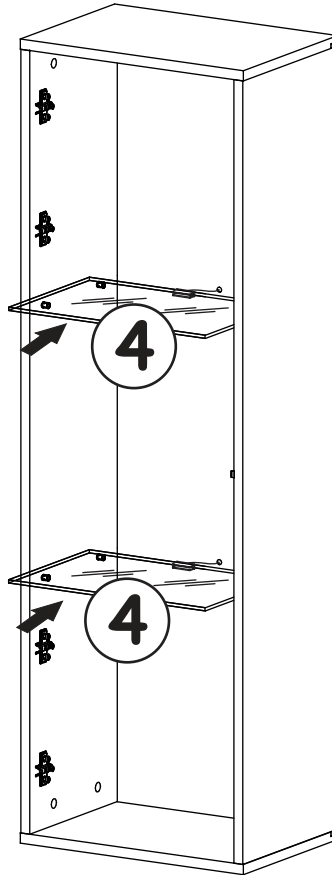
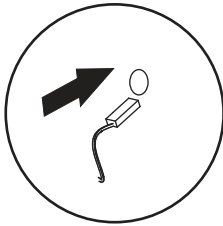
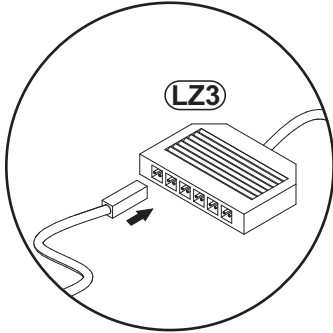
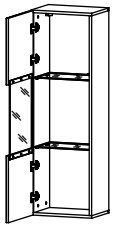

LZ3		LED	
x1		x2	

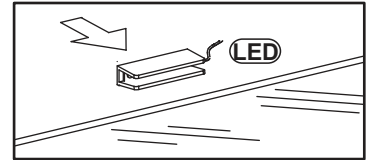

12

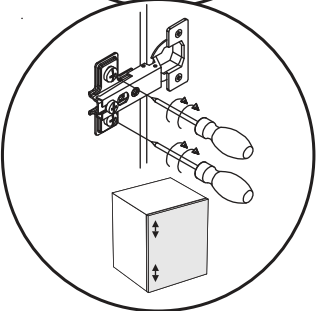
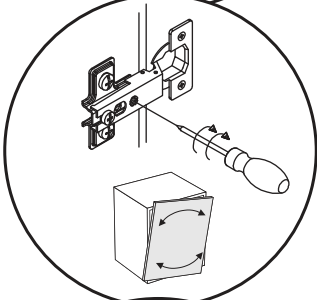
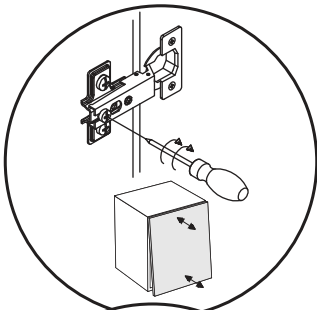

AM		D10	US09/64"x33/64"
x1		X2	USØ3,5x13

