









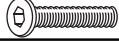
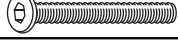

Round Table

Dining Table - Top
 Dining Table - Base
 Counter Table - Top
 Counter Table - Base

Examine all packaging material for small parts that may have come loose during shipment. Periodic checks are recommended to insure that all components are in proper position, tight and free from damage. Keep this assembly instruction for future reference. Adult assembly is required.

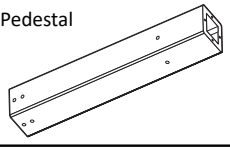
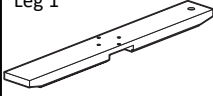
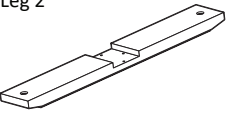
CODE	QTY	HARDWARE	
1	4	Ø5/16" x 2½" Hex Nuts	
2	4	Ø5/16" Spring Washers	
3	4	Ø5/16" Flat Washers	
4	8	M6 x 40mm Allen Bolts	
5	12	M6 x 60mm Allen Bolts	
6	20	M6 Spring Washers	
7	1	Open Wrench	
8	1	Allen Wrench	
9	4	Adjustable Feet	
10	8	Wood Button	

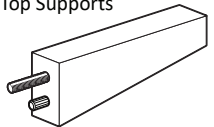
CODE	QTY	COMPONENTS	CODE	QTY	COMPONENTS
A	1	Table Top 	B	1	Pedestal 
C	1	Leg 1 	D	1	Leg 2 
E	4	Bottom Supports 	F	4	Top Supports 

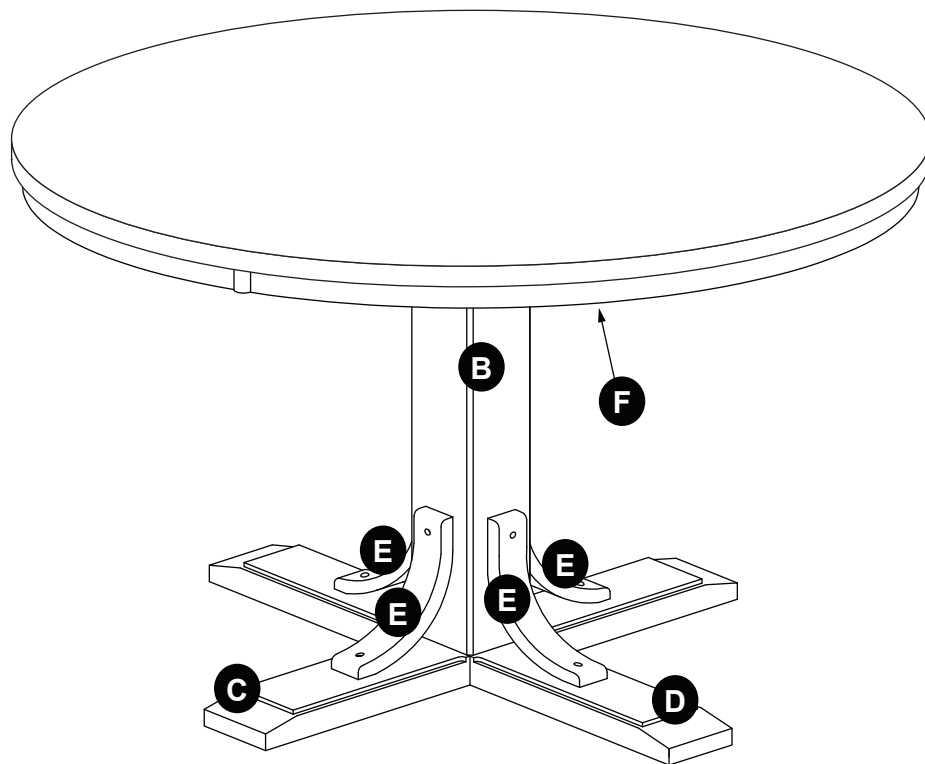

⚠ WARNING

- Do not let any sharp objects touch or rub the surface of the product.
- When assembling, do not let children play around the working area.
- Please confirm all parts are correct before starting the assembly process.
- Do not tighten all bolts and screws completely until the entire unit has been assembled and set up.
- Be careful if using power tools as they can over tighten screws and strip threads.

CARE & MAINTENANCE: The touch of a soft cloth is all the maintenance the finish will ever need. Please do not use harsh or abrasive cleaners for polishing, as they may cause damage to the finish. Periodic checks are recommended to make sure that all hardware is securely tightened.

Round Table

Dining Table - Top
Dining Table - Base
Counter Table - Top
Counter Table - Base

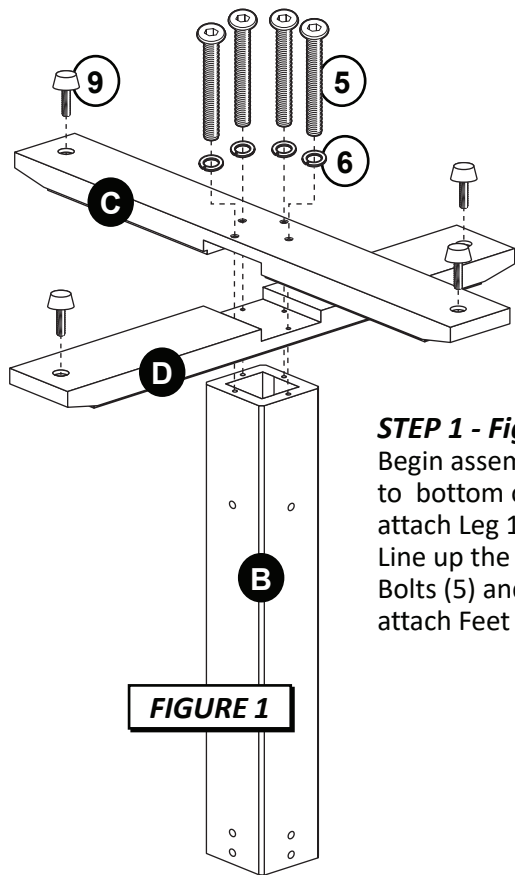

STEP 1 - Figure 1

Begin assembly by putting Leg 2 (D) on to bottom of Pedestal (B) and then attach Leg 1 (C) over the top of Leg 2 (D). Line up the holes and secure with Allen Bolts (5) and Spring Washers (6). Next attach Feet (9) to bottom of Legs (C & D).

FIGURE 1

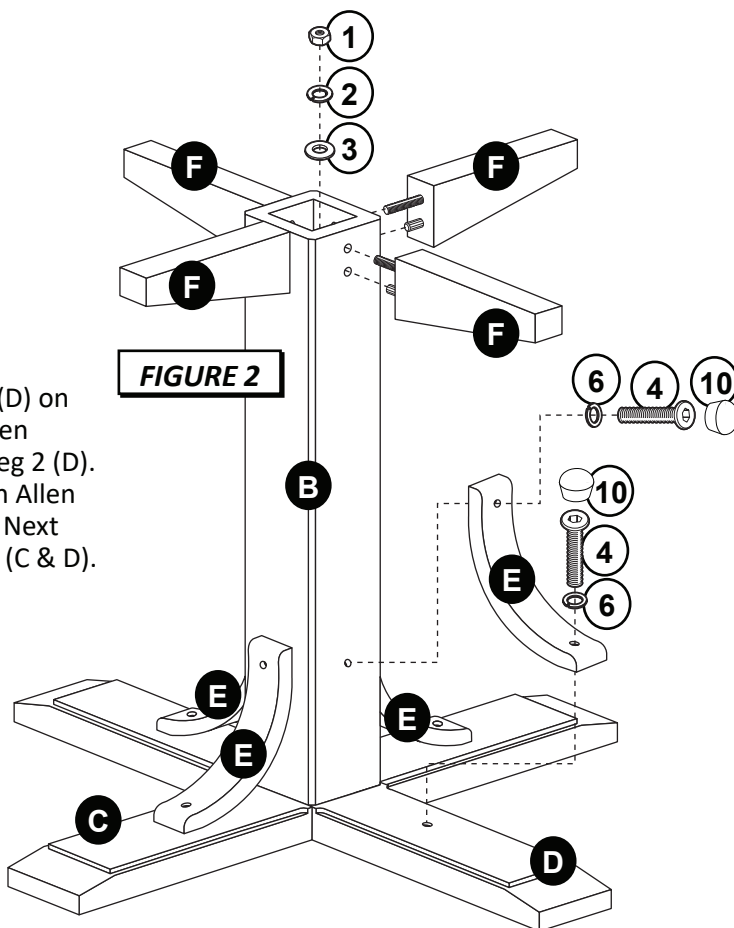

STEP 2 - Figure 2

Attach Bottom Supports (E) to Legs (C & D) and Pedestal (B) using 2 Allen Bolts (4) and 2 Spring Washers (6) per support. Tighten all bolts using Allen Wrench (8) provided. Insert each Wood Button (10) to cover the bolt head.

STEP 3 - Figure 2

Attach Top Supports (F) to Pedestal (B) by sliding into place and securing from the inside with 1 Flat Washer (3), 1 Spring Washer (2) and 1 Nut (1) per support. Tighten nuts using Open Wrench (7) provided.

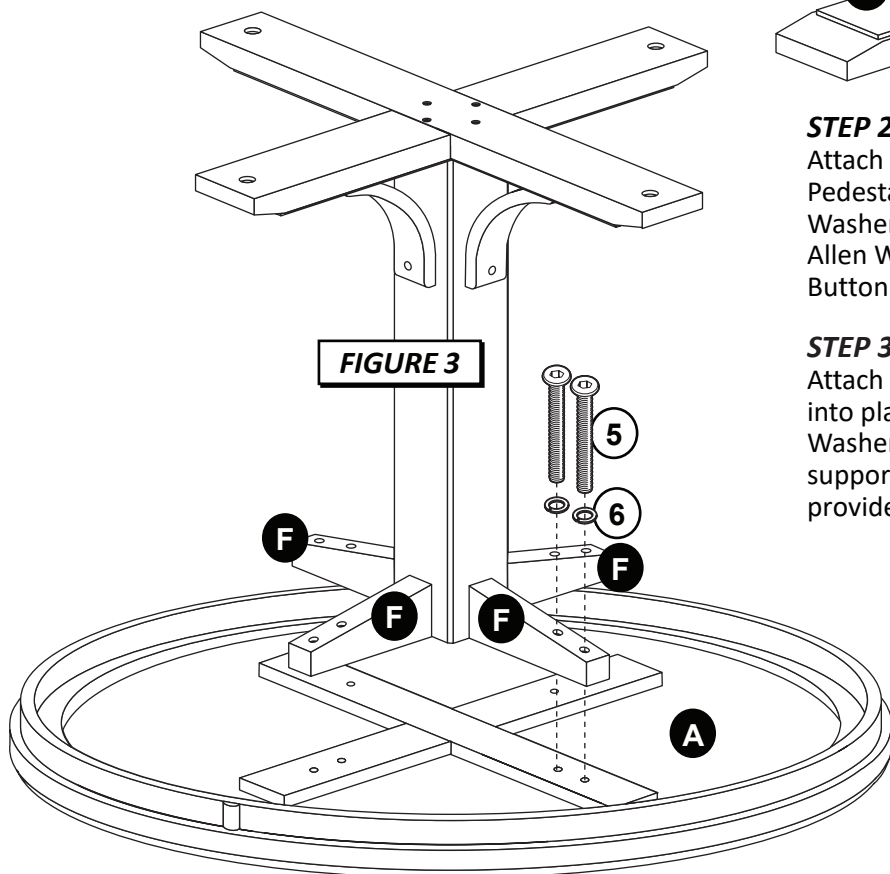

FIGURE 3

STEP 4 - Figure 3

Put Table Top (A) upside down on a clean smooth surface to prevent scratching. Attach bottom assembly to Table Top (A) by using 2 Allen Bolts (5) and 2 Spring Washers (6) through each Top Support (F). Tighten all bolts using Allen Wrench (8) provided. Return table to upright position. The assembly is now complete.