

Parts and Damage Replacement Procedure

1. Please inspect your purchase immediately.
2. This procedure covers product purchased from an authorized Reseller and was received in its originally sealed carton.

**A COPY OF YOUR PURCHASE RECEIPT OR INVOICE MUST BE ATTACHED TO THIS ORDER FORM.
NO ORDERS WILL BE PROCESSED WITHOUT PROOF OF PURCHASE.**

NAME: _____

ADDRESS: _____ (No Post Office Boxes)

CITY: _____ STATE: _____ ZIP: _____

PHONE: _____ FAX: _____

EMAIL: _____

REASON FOR REPLACEMENT/PLEASE CHECK APPROPRIATE BOX.

- Damaged /scratched, cracked, broken, crushed, etc.
- Mechanical malfunction/ drawer glides, swivel mechanisms, lid stays, etc.
- Missing pieces
- Unfinished surface
- Wrong color
- Other

IF MORE THAN ONE MODEL NUMBER IS LISTED ABOVE, PLEASE SPECIFY THE EXACT MODEL NUMBER OF YOUR ITEM IN THE SPACE PROVIDED BELOW.

ASSEMBLY INSTRUCTIONS

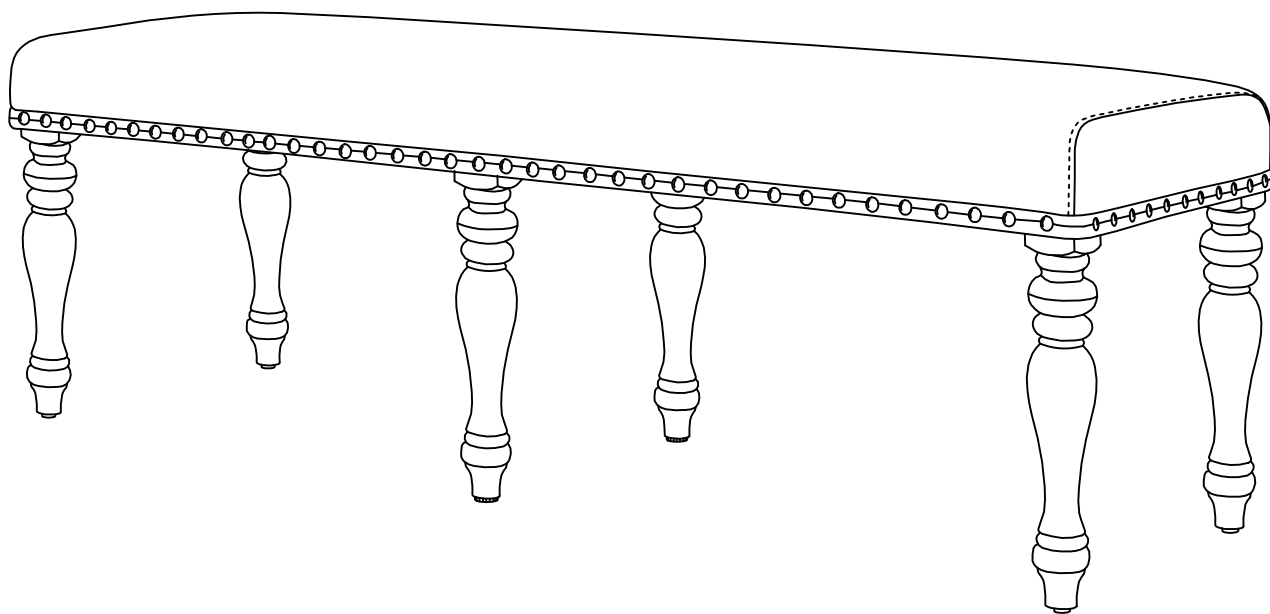

ASSEMBLY INSTRUCTIONS

Parts List

1. SEAT
1. piece

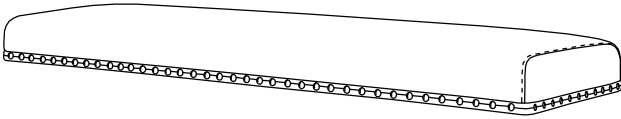

2. SIDE LEG
4. piece



3. CENTER LEG
2. piece



Hardware List

4. JCBC BOLT M6 X 60mm
14. pieces

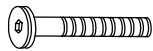

5. SPRING WASHER
14. pieces



6. FLAT WASHER
14. pieces



7. ALLEN KEY
1. piece



ASSEMBLY INSTRUCTIONS

STEP 1

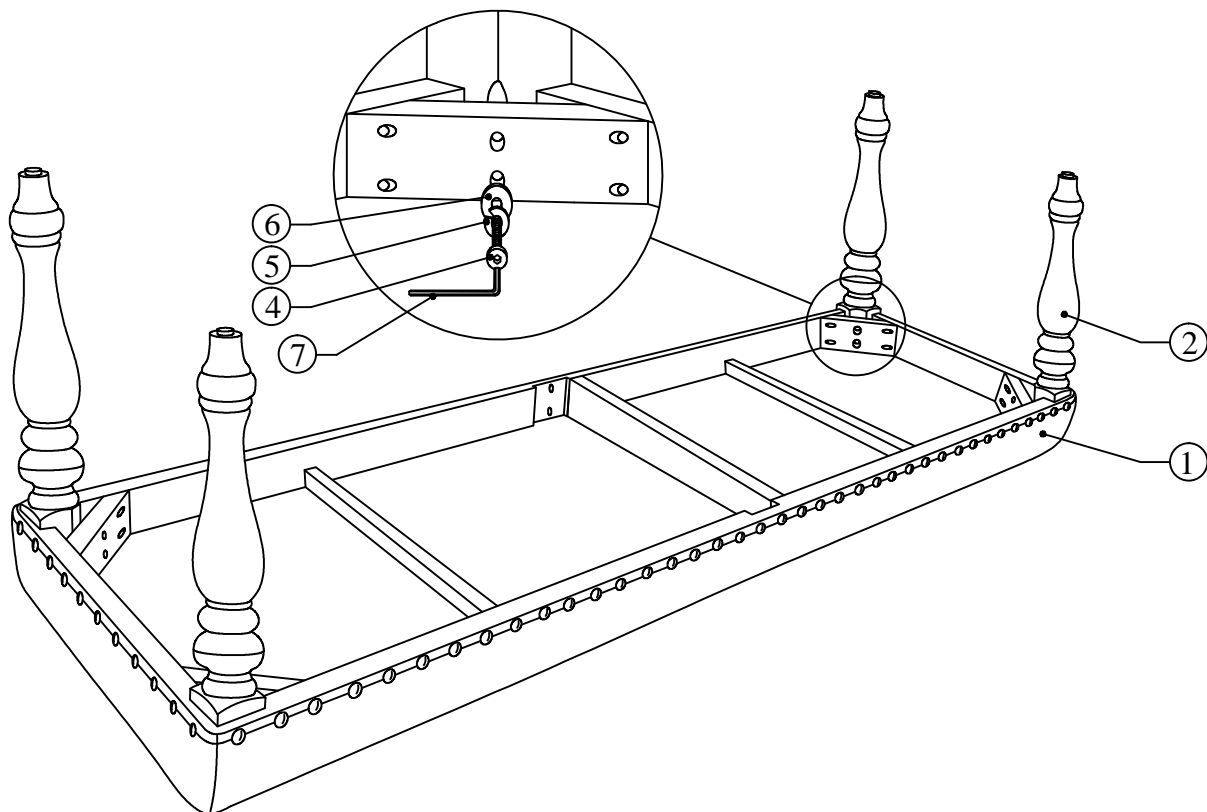

STEP 2

Adjust leveler to level unit

