

# ASSEMBLY INSTRUCTIONS

V-TS23-0215A

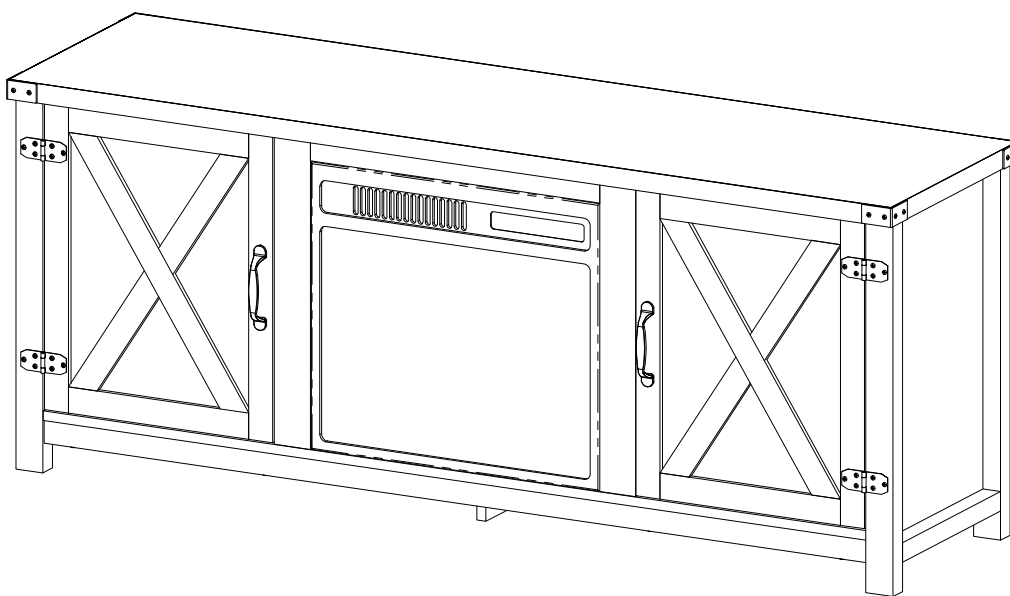

# WARNING!

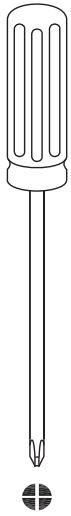

**MAXIMUM LOAD  
220lb/100kg**

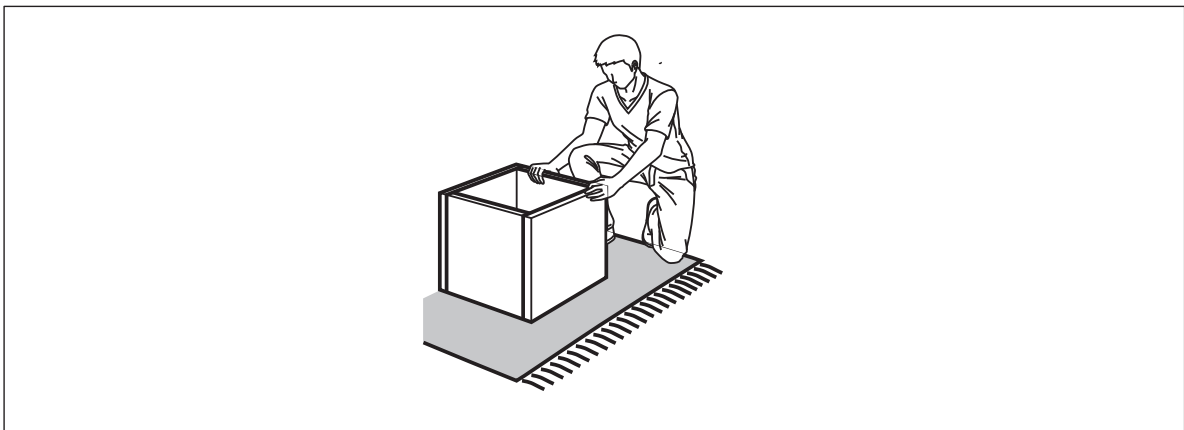
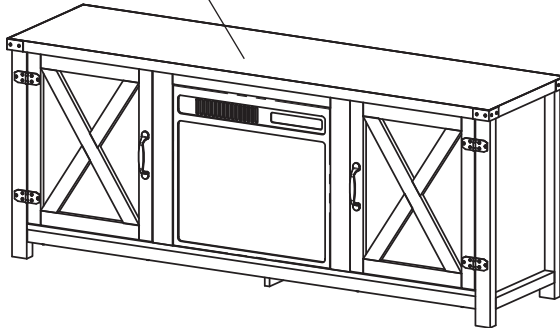

Assemble the furniture on empty carton, carpet, or rug to prevent scratches or damage.

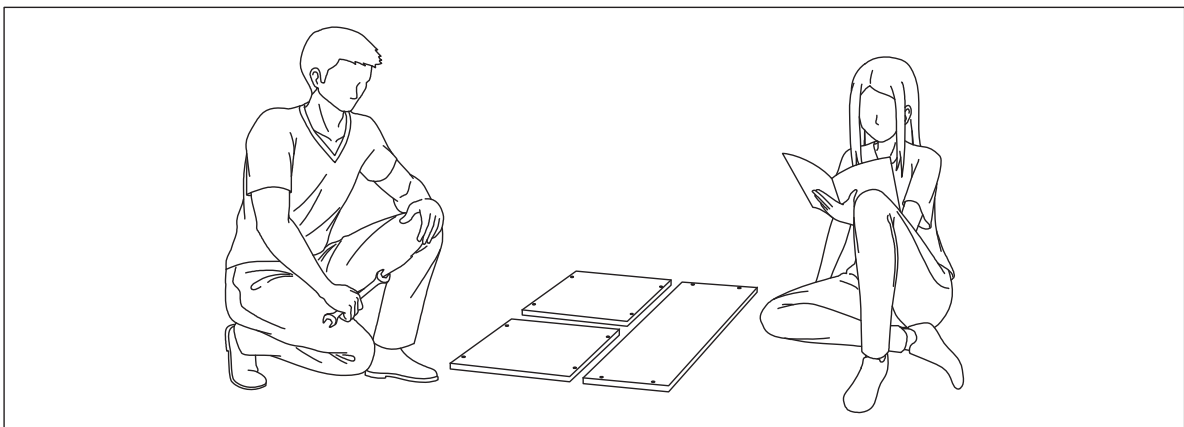

This furniture requires 2 people to assemble.

Make sure no parts are missing or damaged before assemble

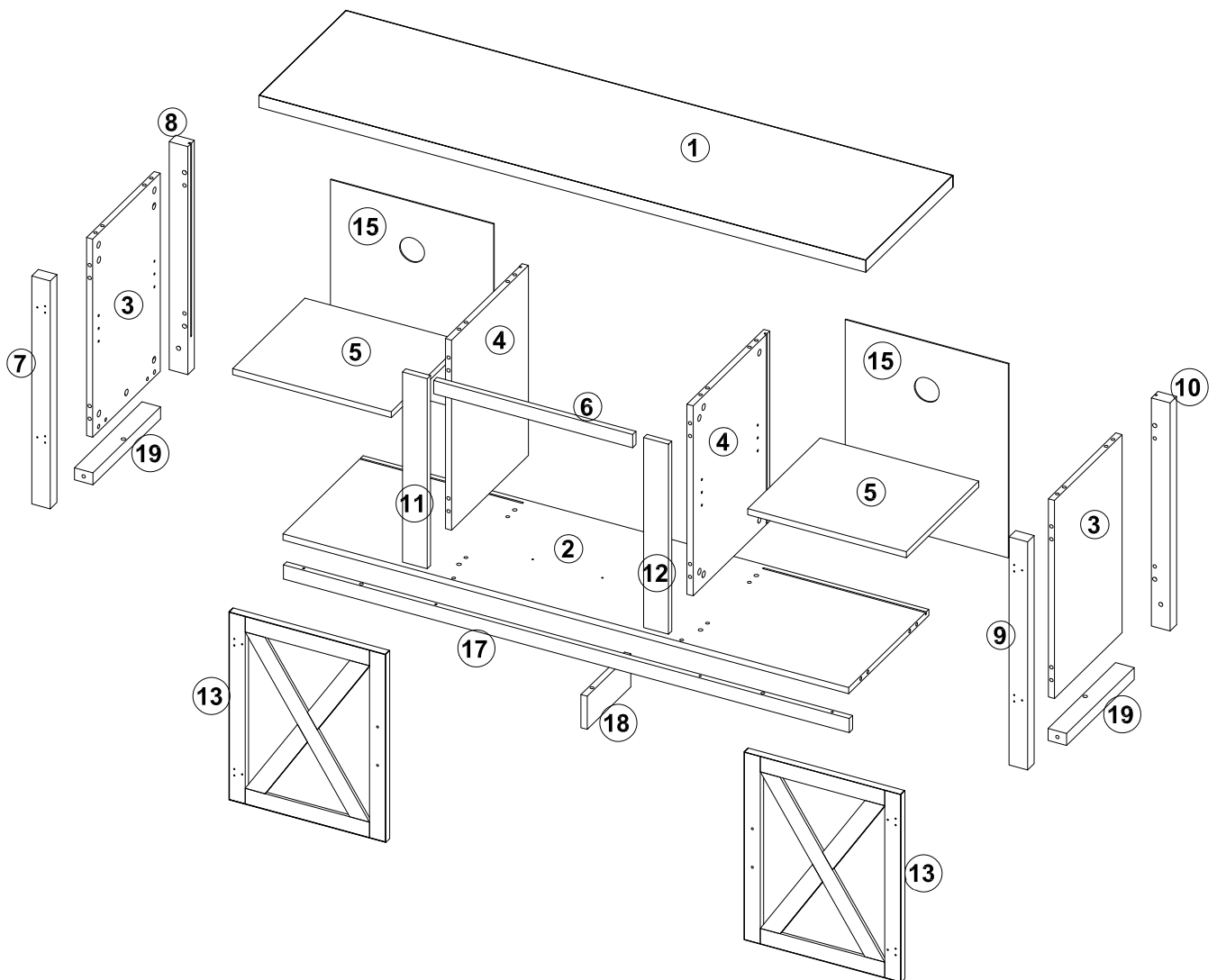

# Board Identification

Not actual size

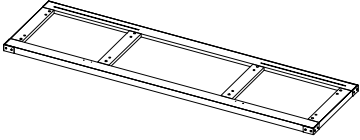
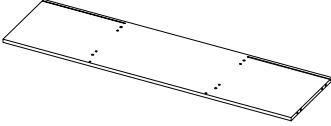
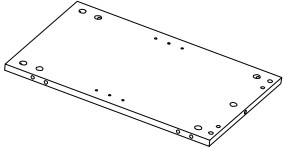
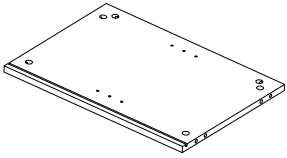
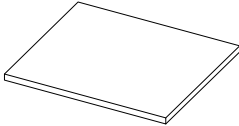

# BOARD IDENTIFICATION

Not actual size

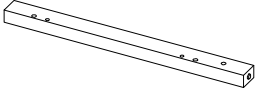
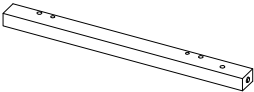
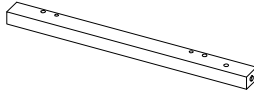
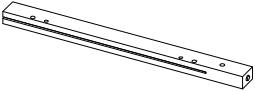
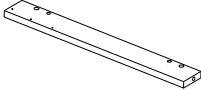
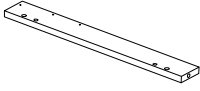
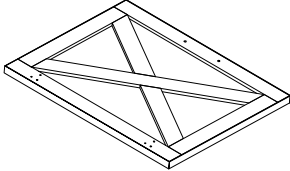
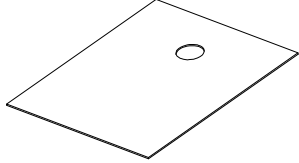
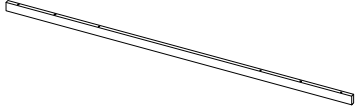
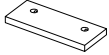
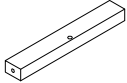
<p>①</p>  <p>Top panel x 1</p>	<p>②</p>  <p>Bottom x 1</p>	<p>③</p>  <p>Side panel x 2</p>
<p>④</p>  <p>Vertical panel x 2</p>	<p>⑤</p>  <p>Adjustable shelf x 2</p>	<p>⑥</p>  <p>Middle rail x 1</p>
<p>⑦</p>  <p>Leg x 1</p>	<p>⑧</p>  <p>Leg x 1</p>	<p>⑨</p>  <p>Leg x 1</p>
<p>⑩</p>  <p>Leg x 1</p>	<p>⑪</p>  <p>Mullion x 1</p>	<p>⑫</p>  <p>Mullion x 1</p>
<p>⑬</p>  <p>Door x 2</p>		<p>⑮</p>  <p>Back panel x 2</p>
<p>⑰</p>  <p>Bottom rail x 1</p>	<p>⑱</p>  <p>Support bracket x 1</p>	<p>⑲</p>  <p>Bottom rail x 2</p>

# HARDWARE LIST

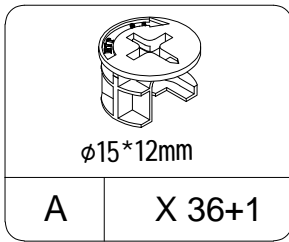

A X 36+1

CAM LOCK

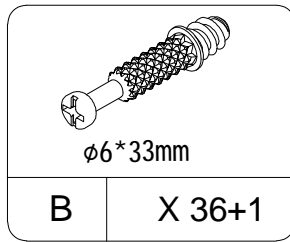

B X 36+1

CAM BOLT

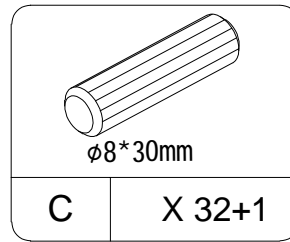

C X 32+1

WOOD DOWEL

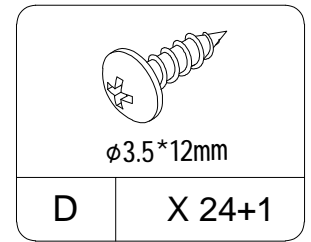

D X 24+1

SCREW

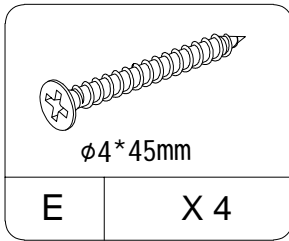

E X 4

SCREW

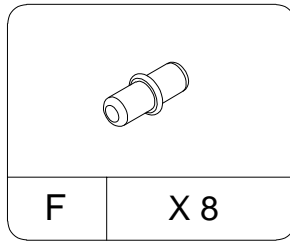

F X 8

SUPPORT PIN

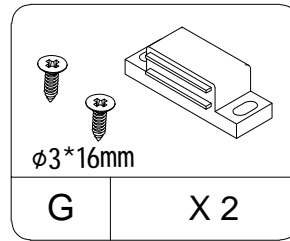

G X 2

MAGNETIC CATCH

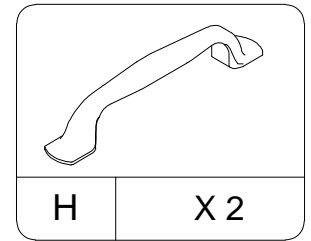

H X 2

HANDLE

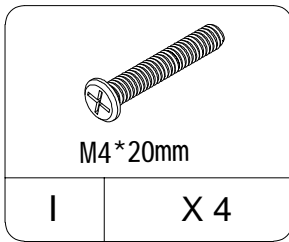

I X 4

BOLT

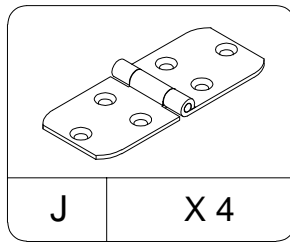

J X 4

FURNITURE HINGE

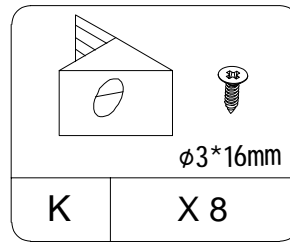

K X 8

MAGNETIC CATCH

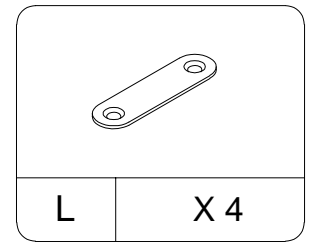

L X 4

PLASTIC

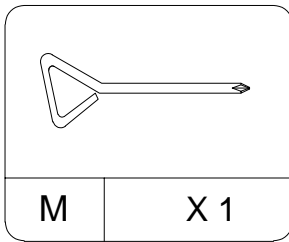

M X 1

SCREWDRIVER

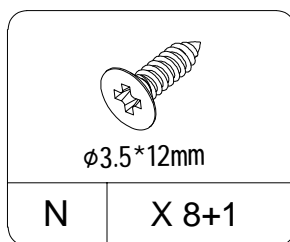

N X 8+1

SCREW

## Cam Lock Fastening System

Insert the cam bolt into the hole first, then insert the cam lock and lock it.

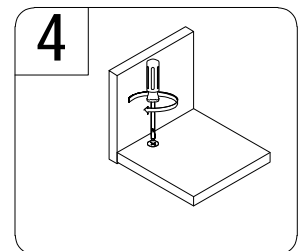
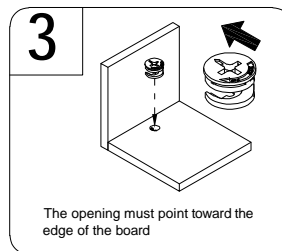
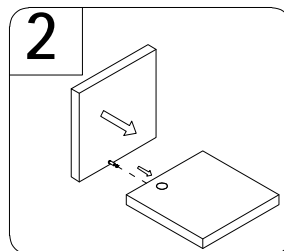
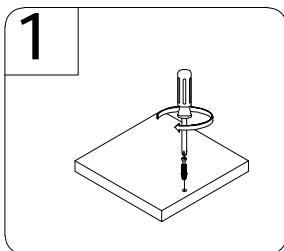

# STEP 1

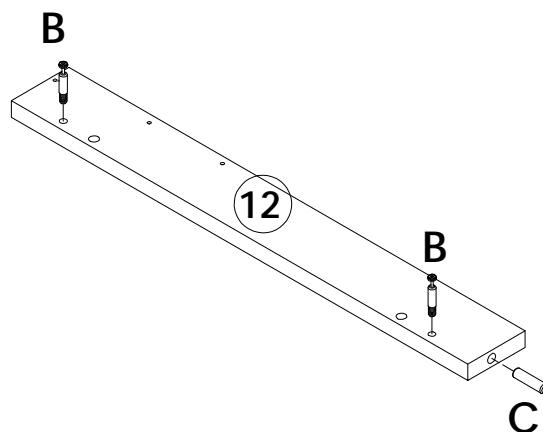
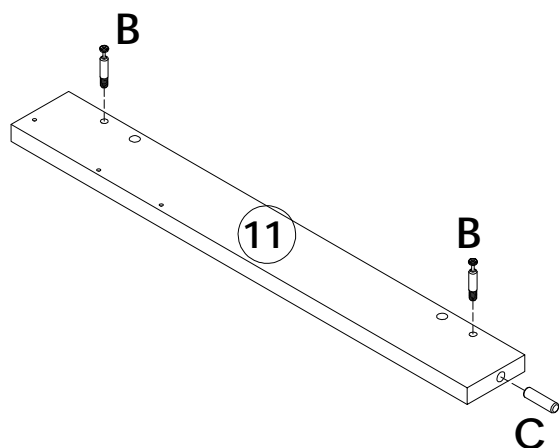
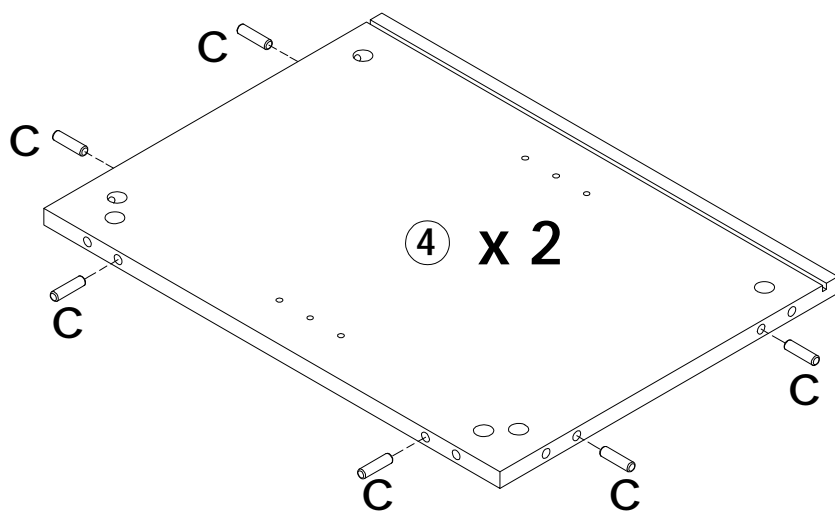
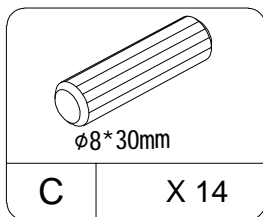
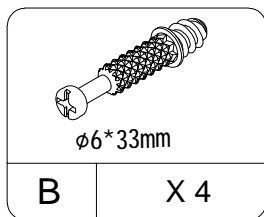

# STEP 2

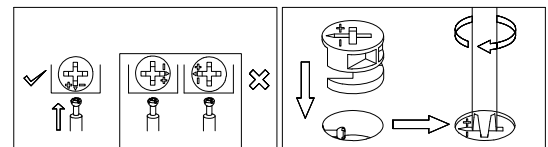
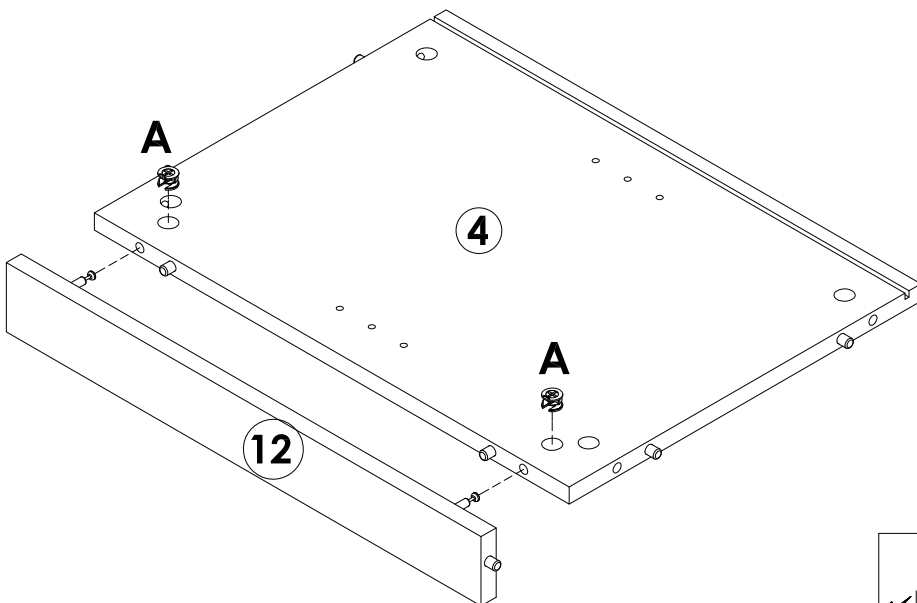
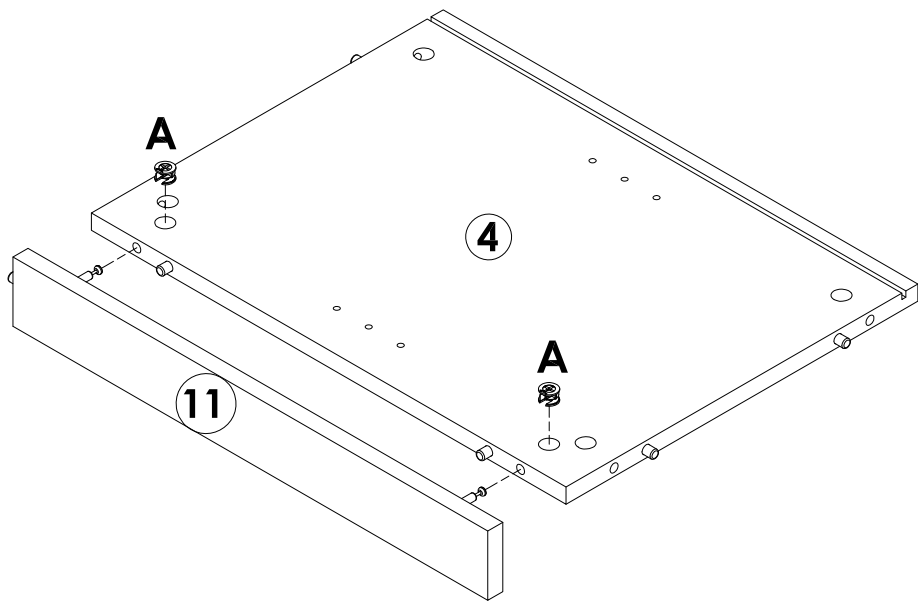
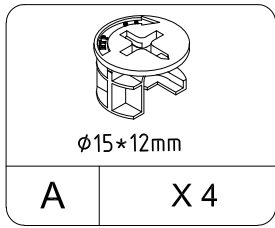

# STEP 3

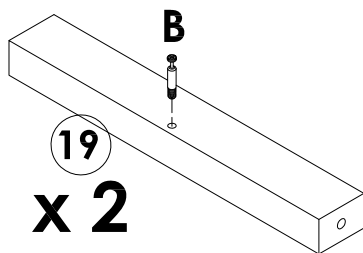
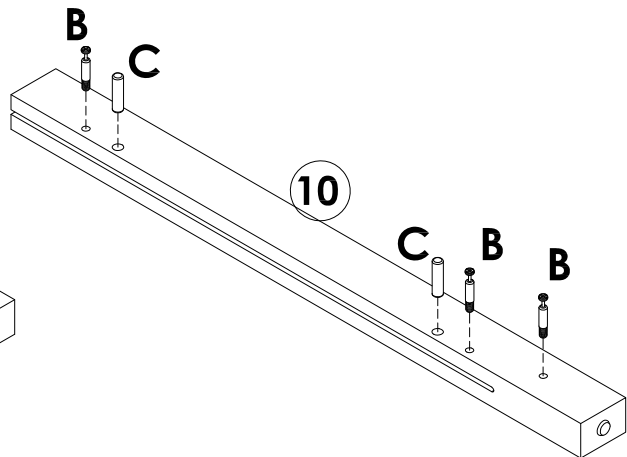
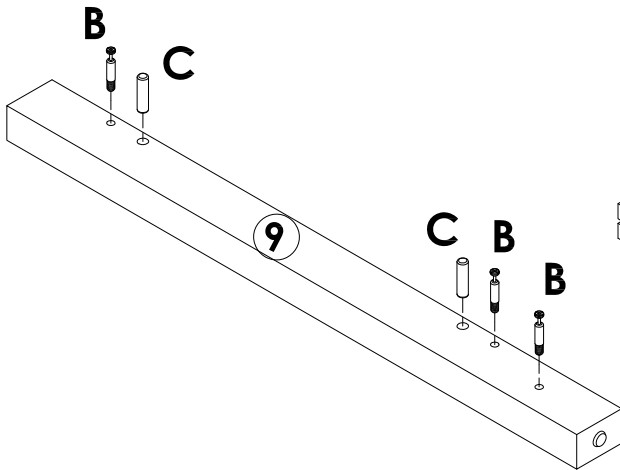
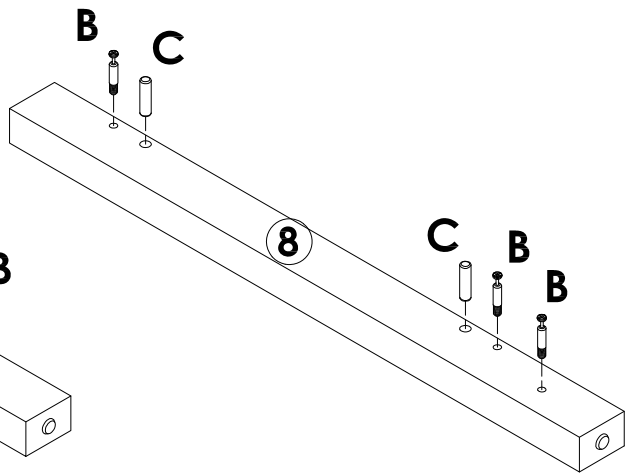
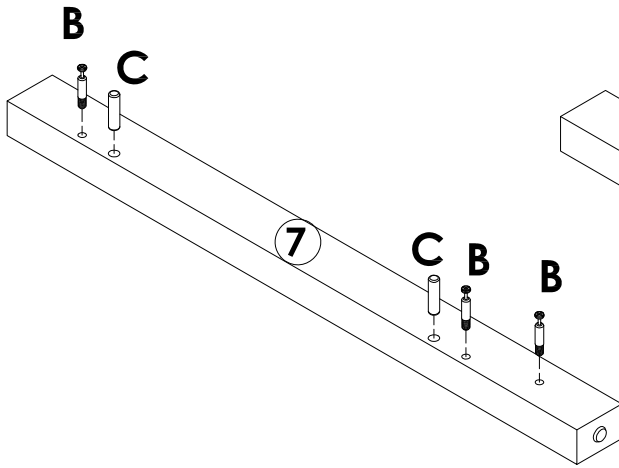
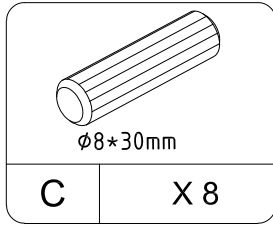
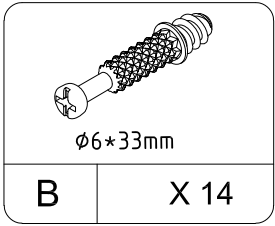

# STEP 4

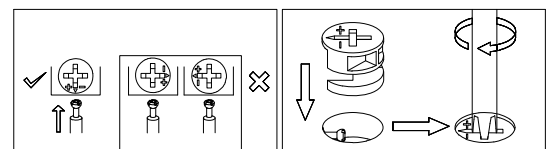
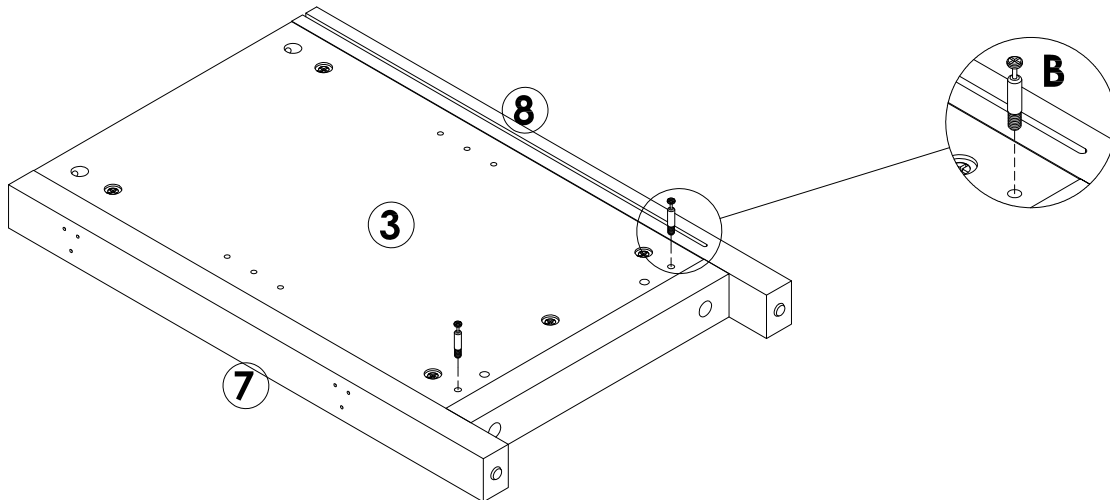
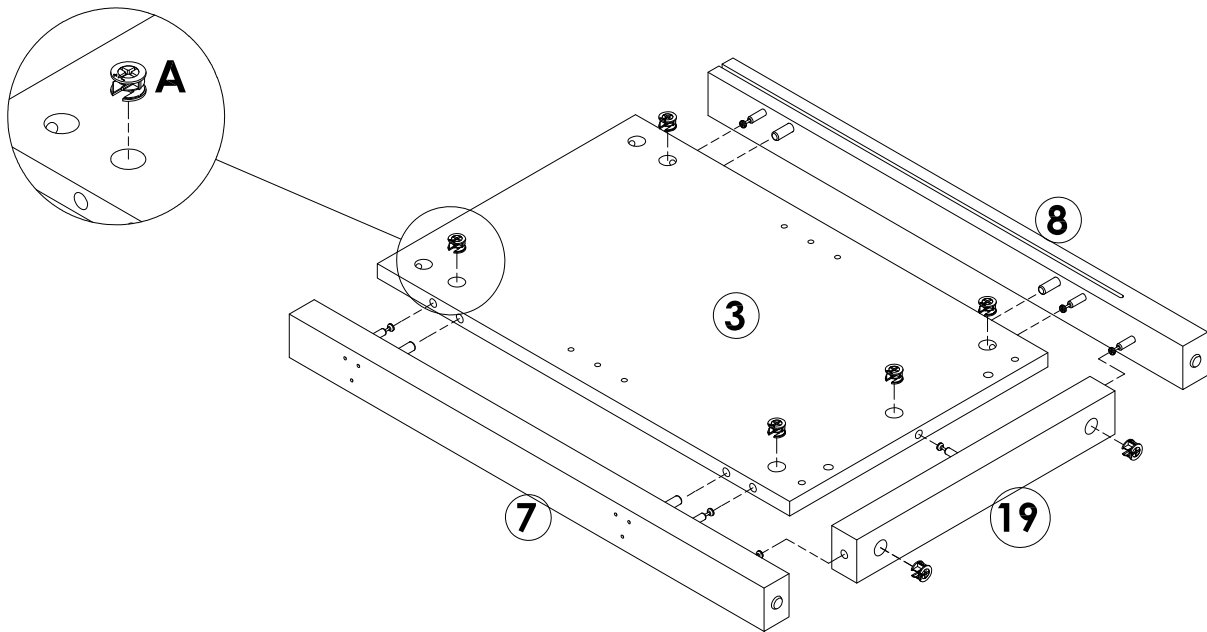
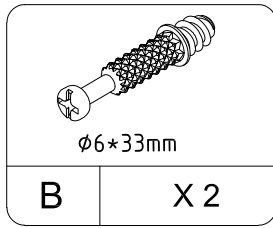
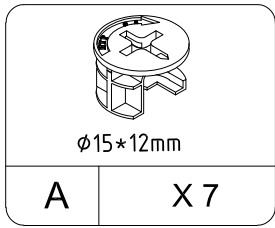

# STEP 5

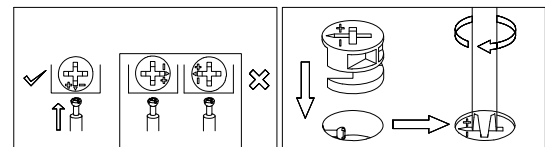
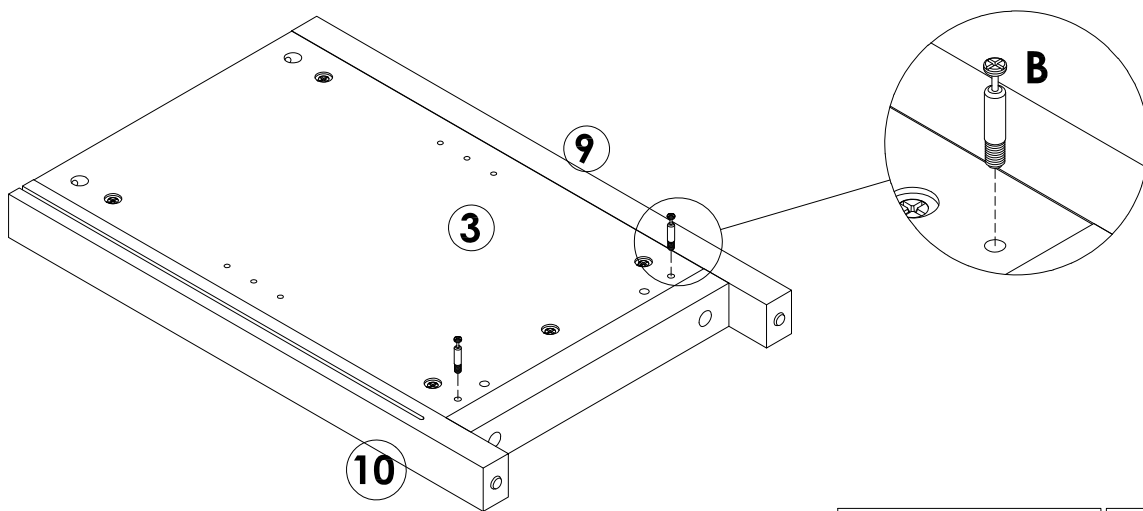
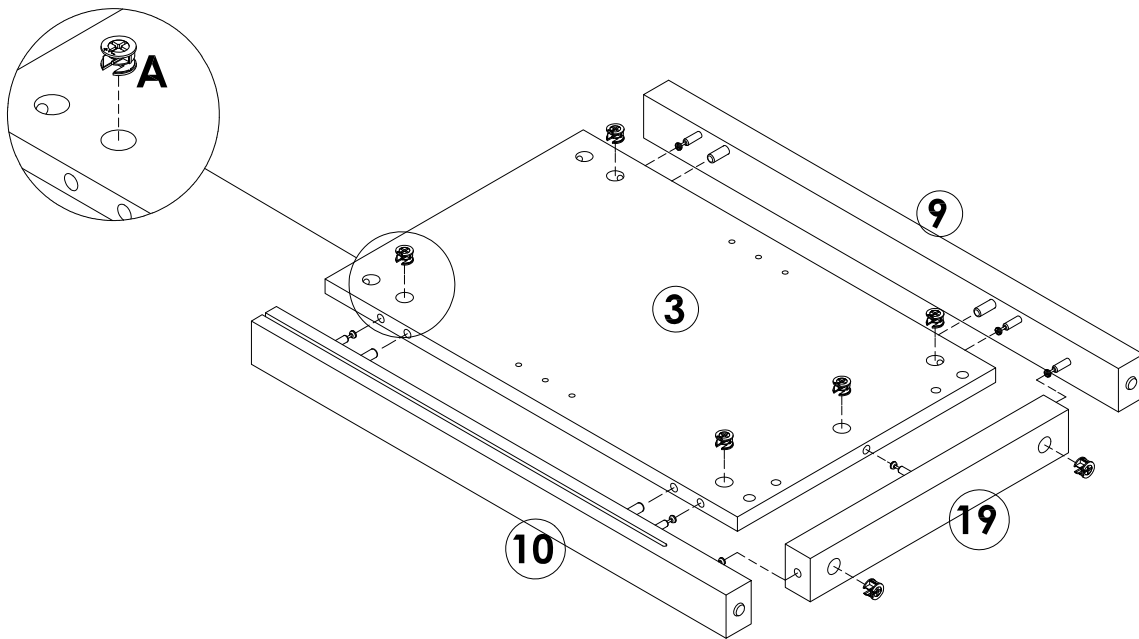
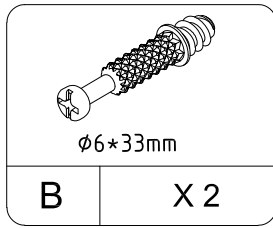
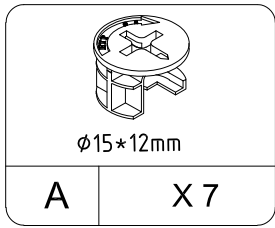

# STEP 6

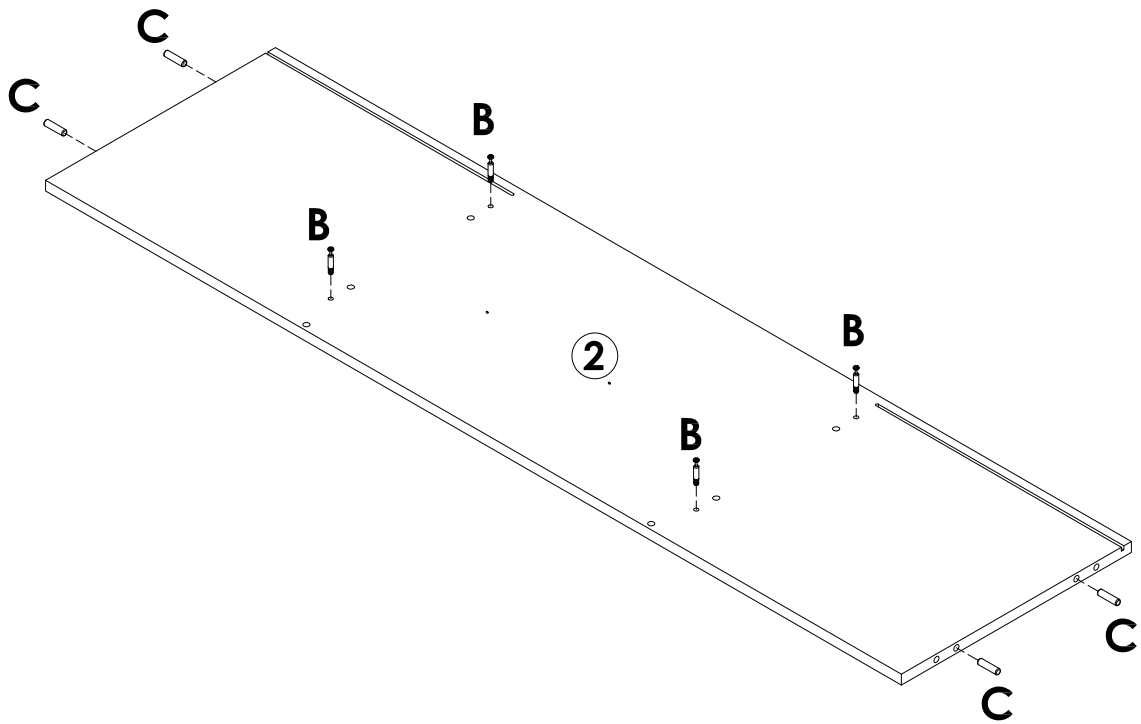
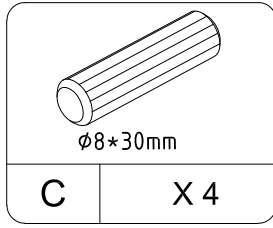
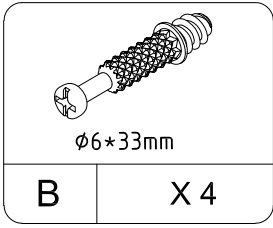

# STEP 7

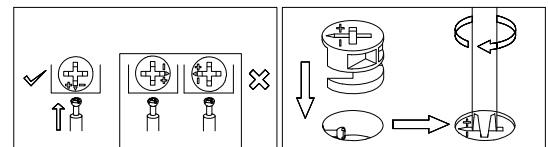
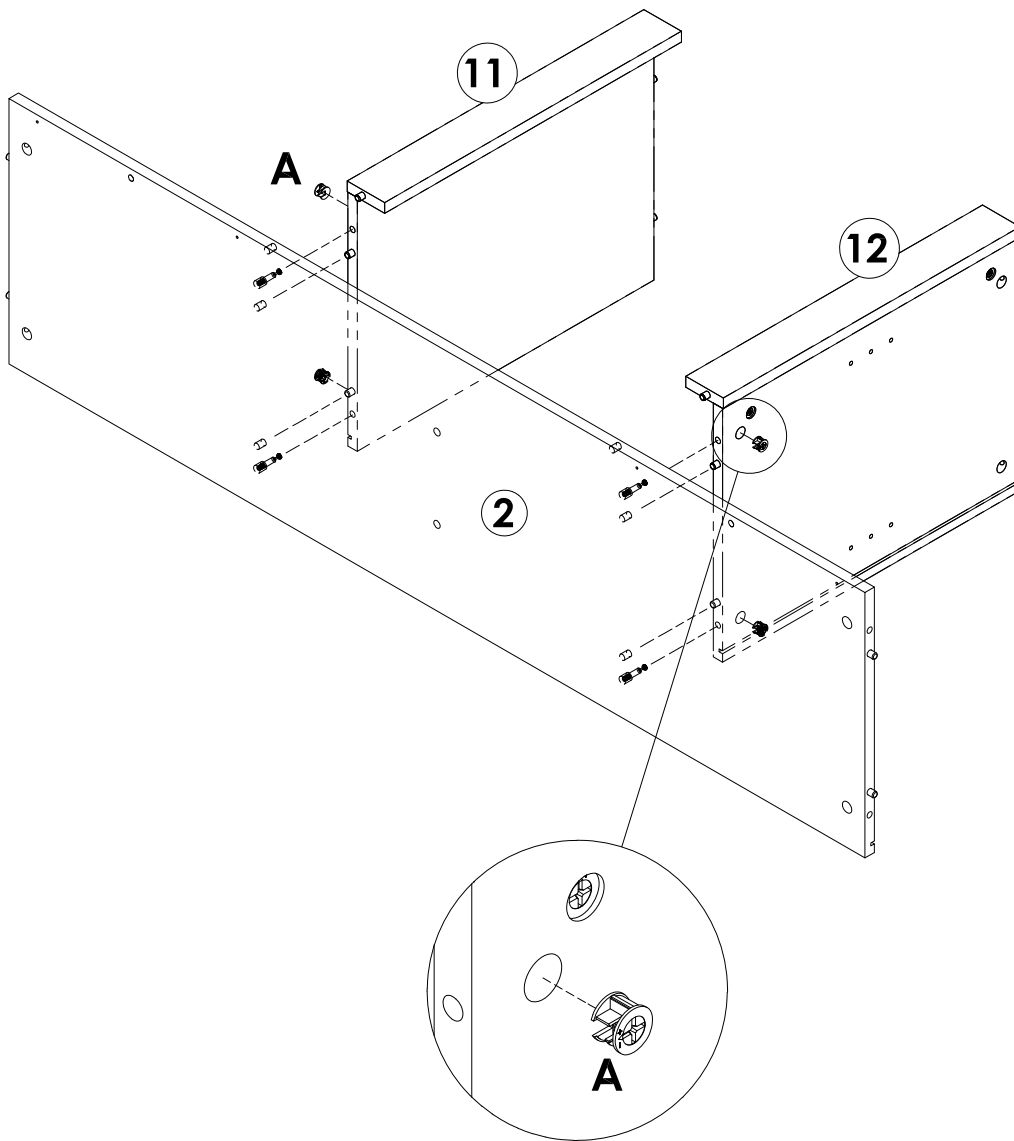
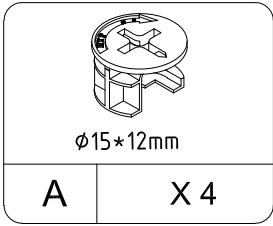

# STEP 8

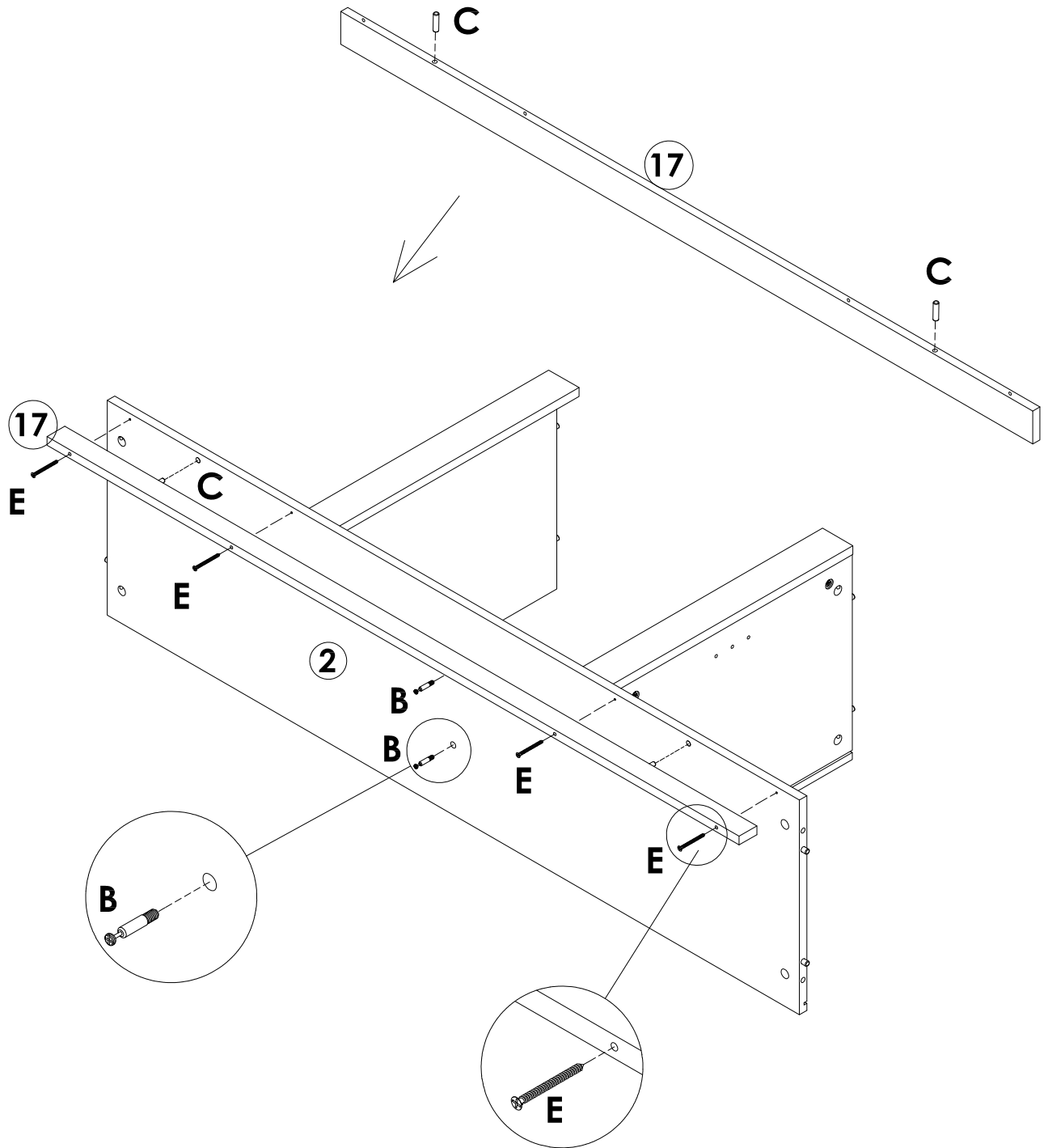
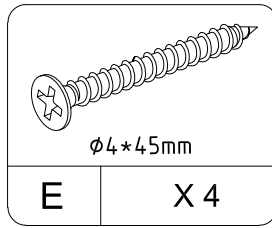
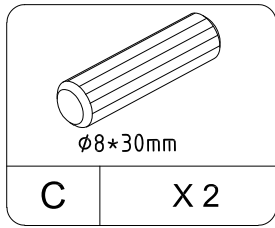
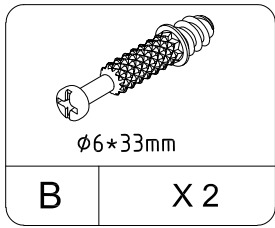

# STEP 9

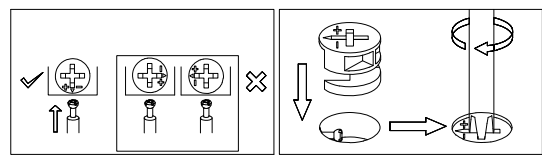
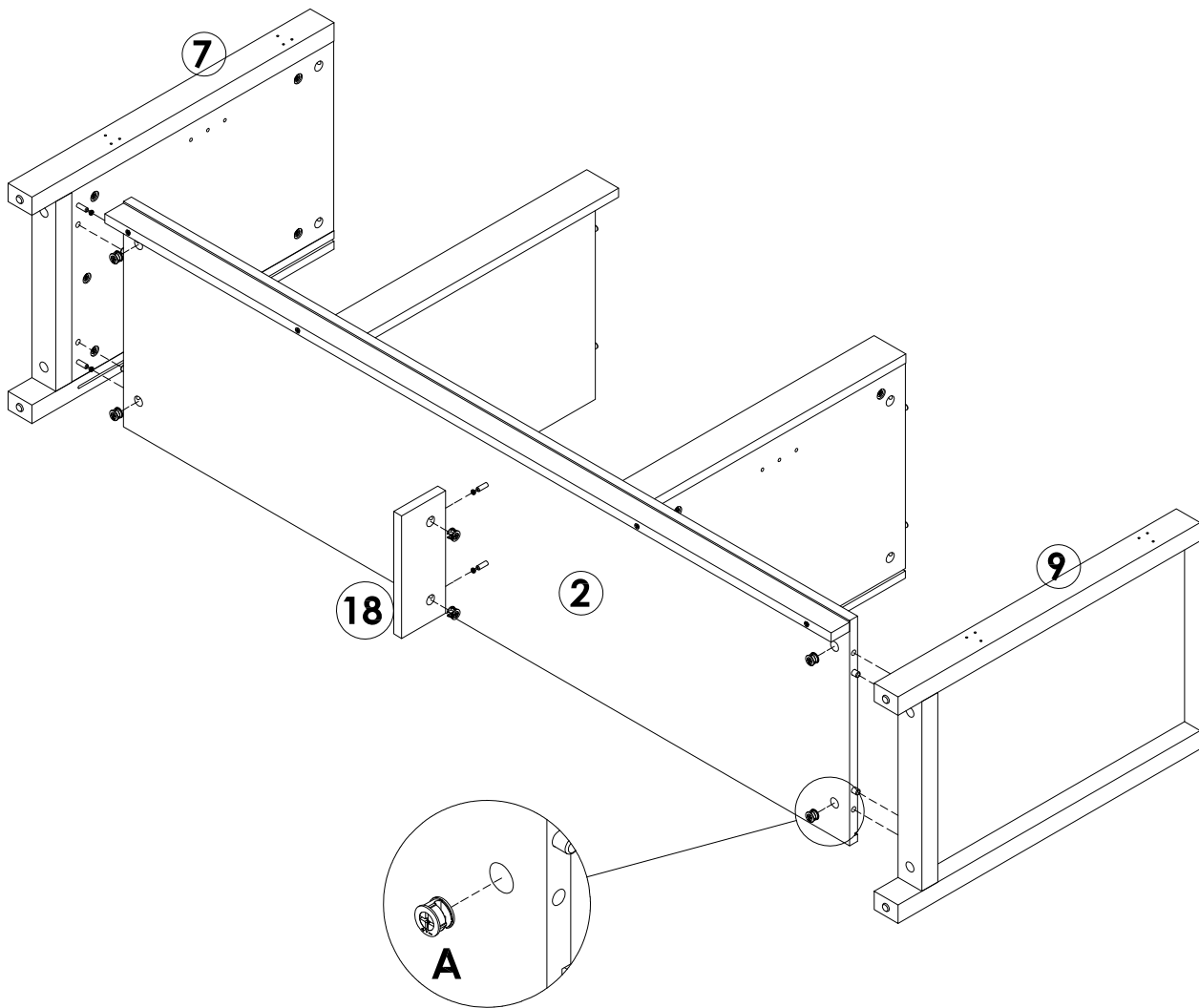
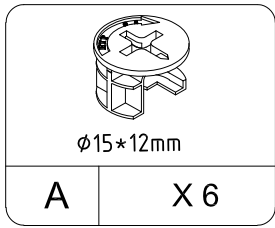

# STEP 10

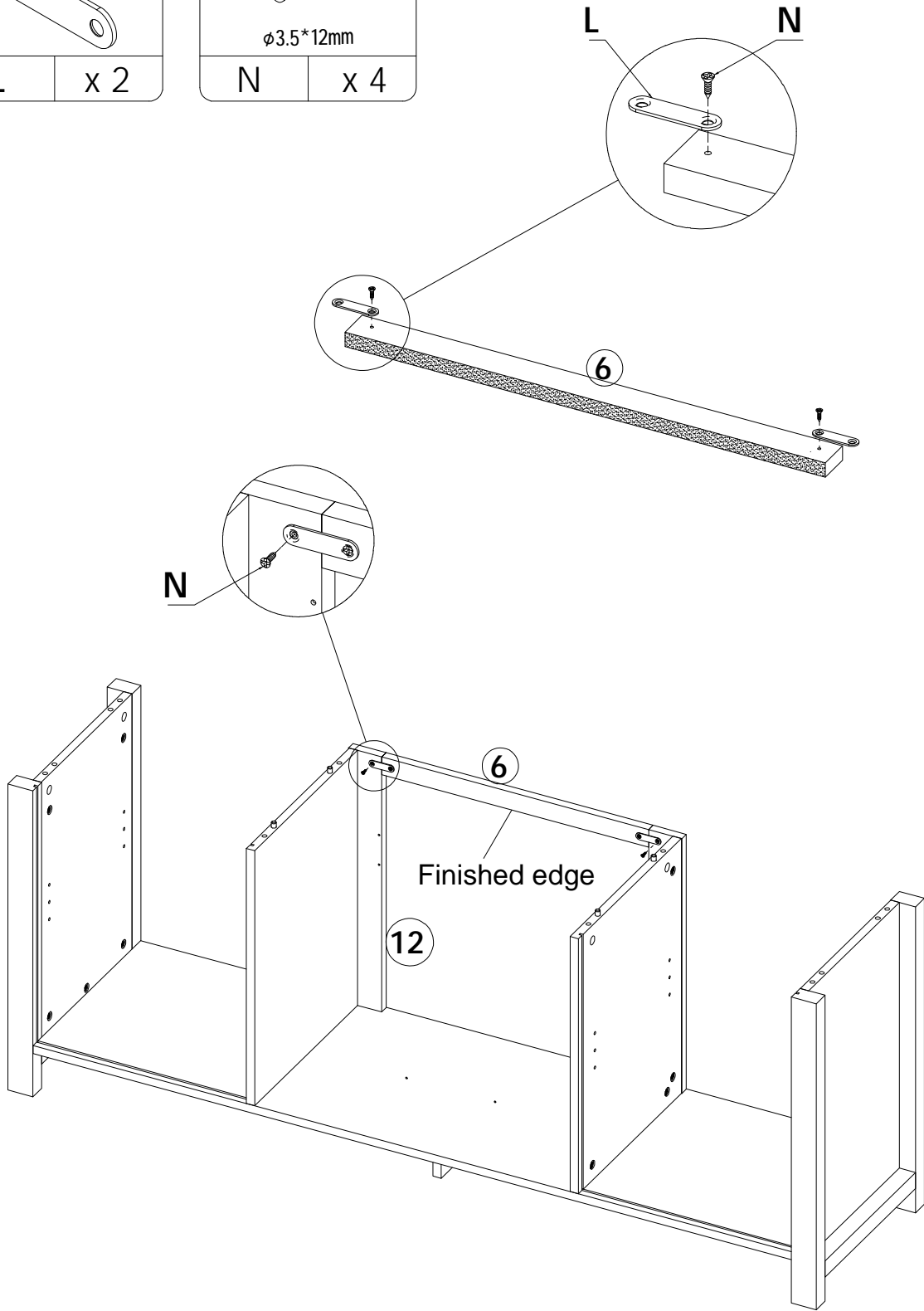
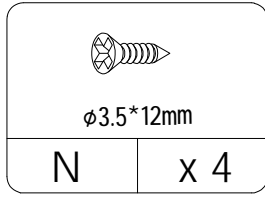
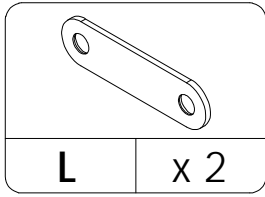

# STEP 11

This step install according to the instruction manual

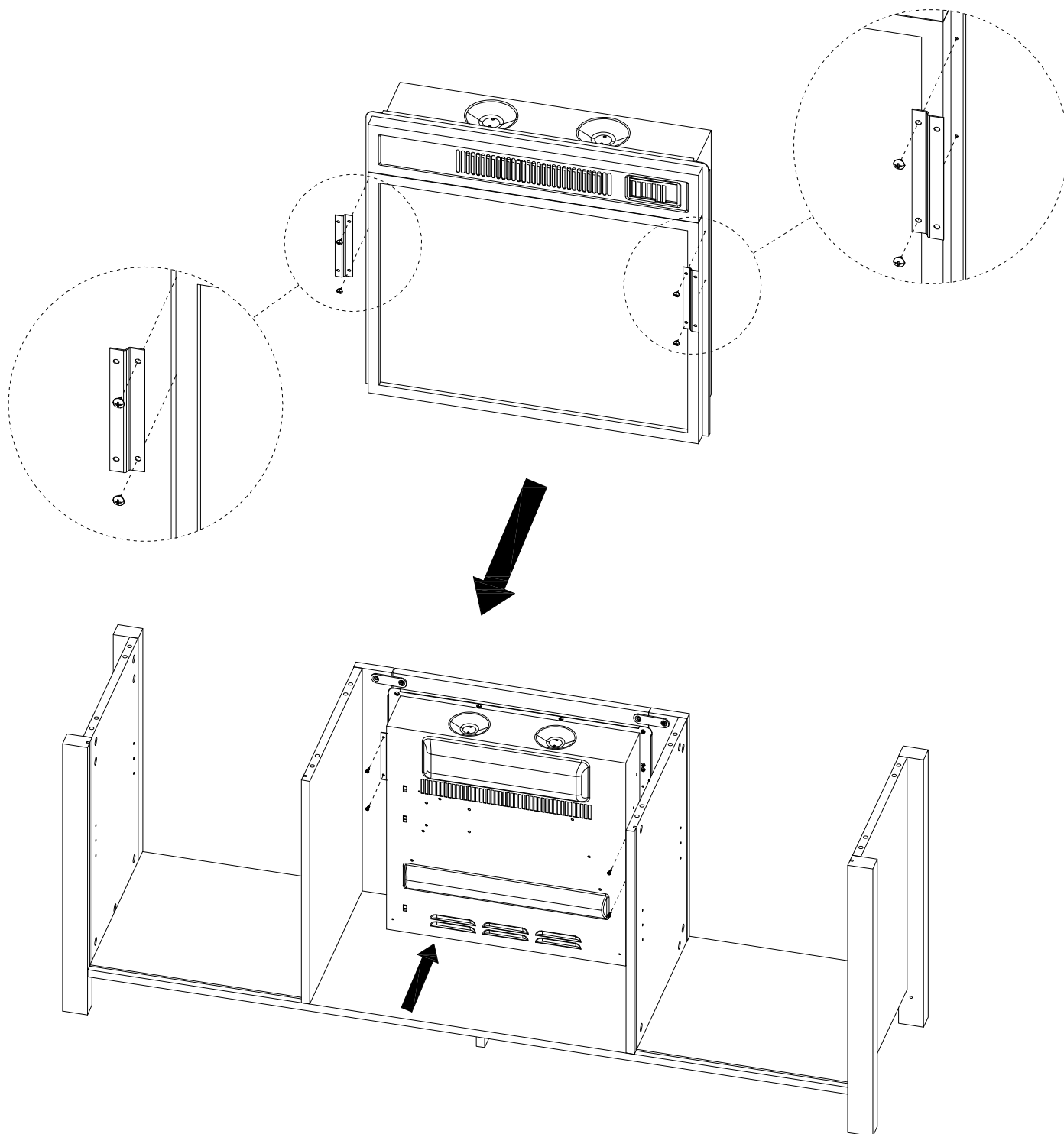

# STEP 12

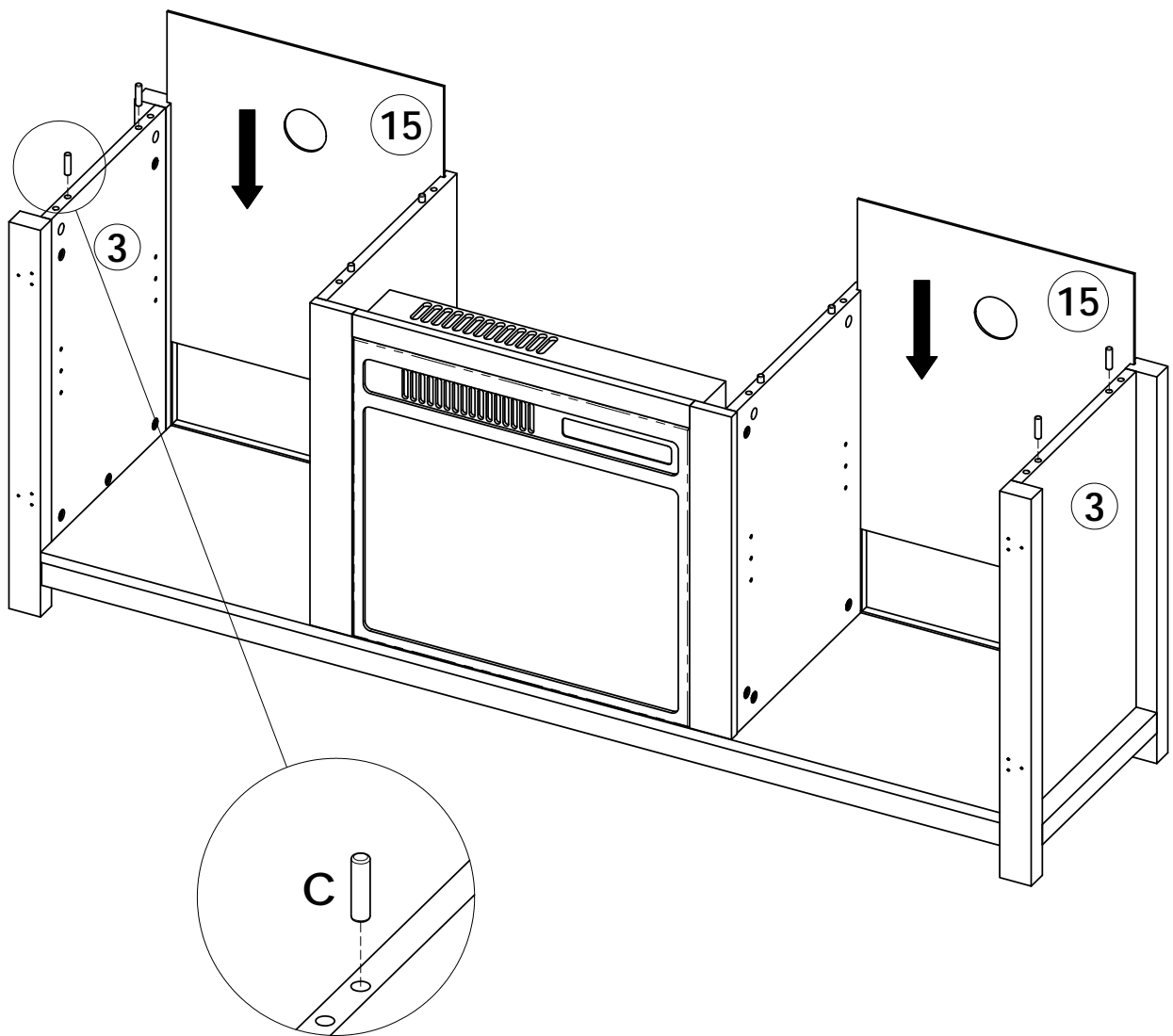
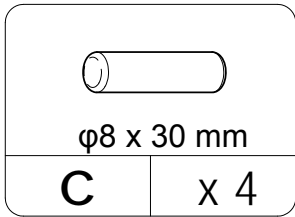

# STEP 13

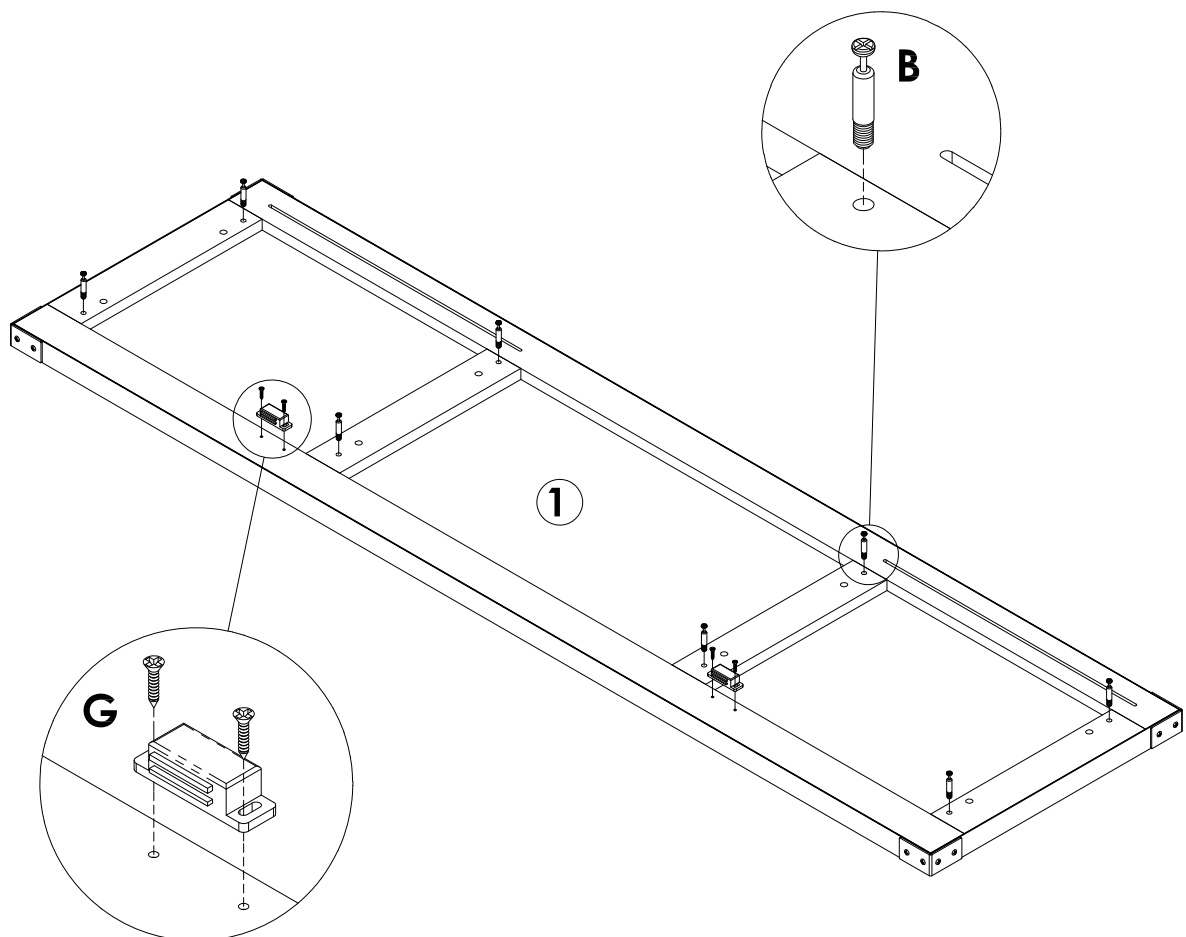
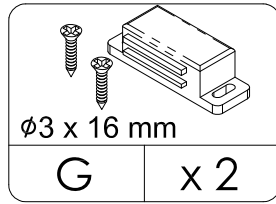
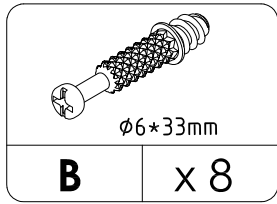

# STEP 14

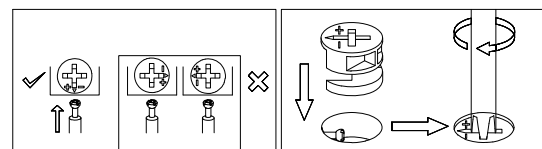
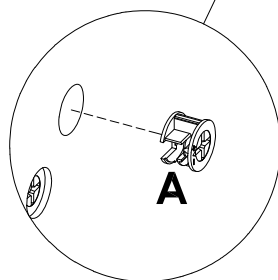
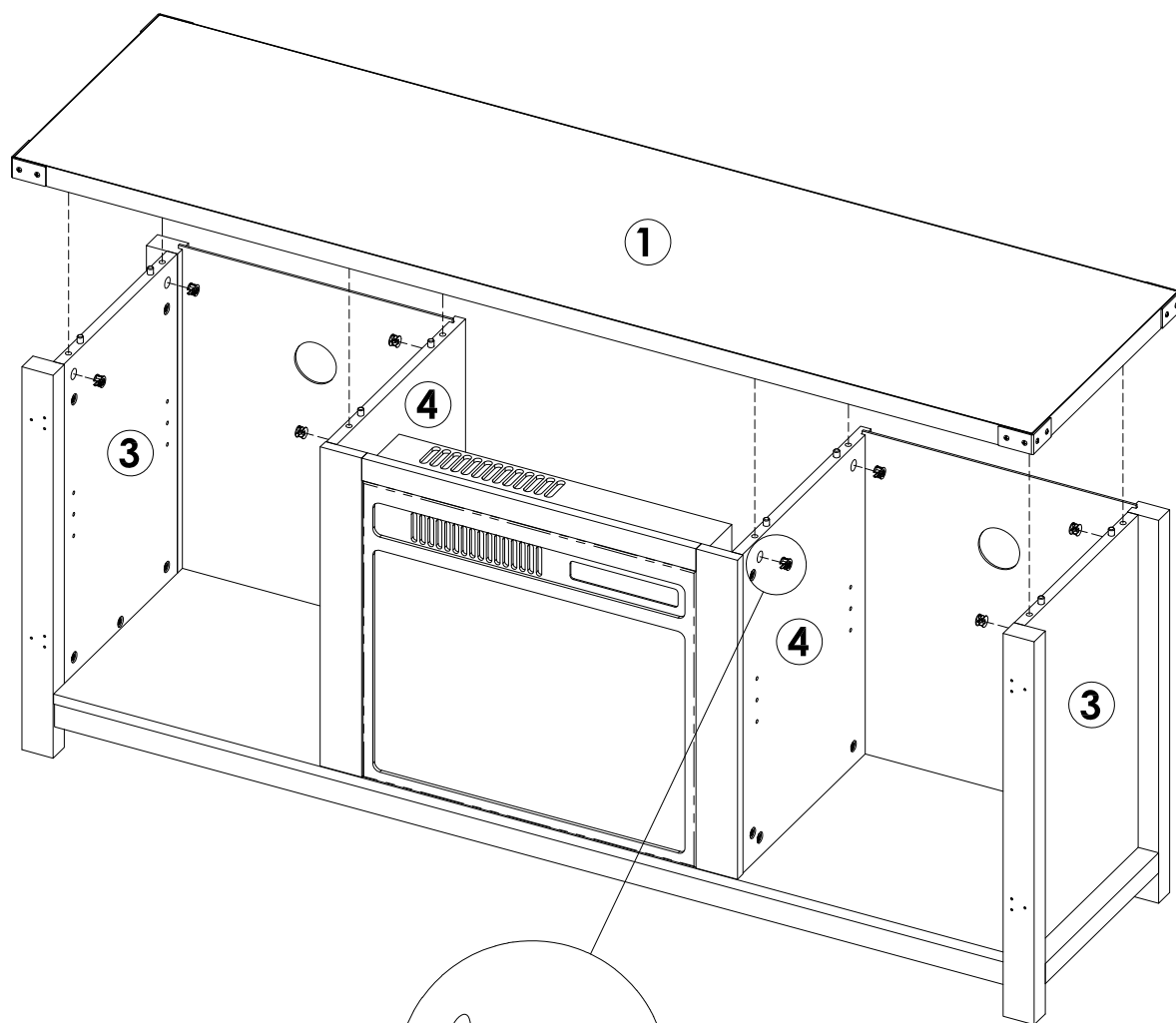
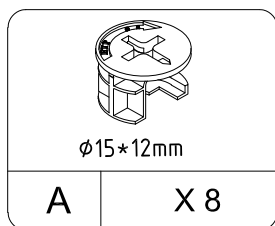

# STEP 15

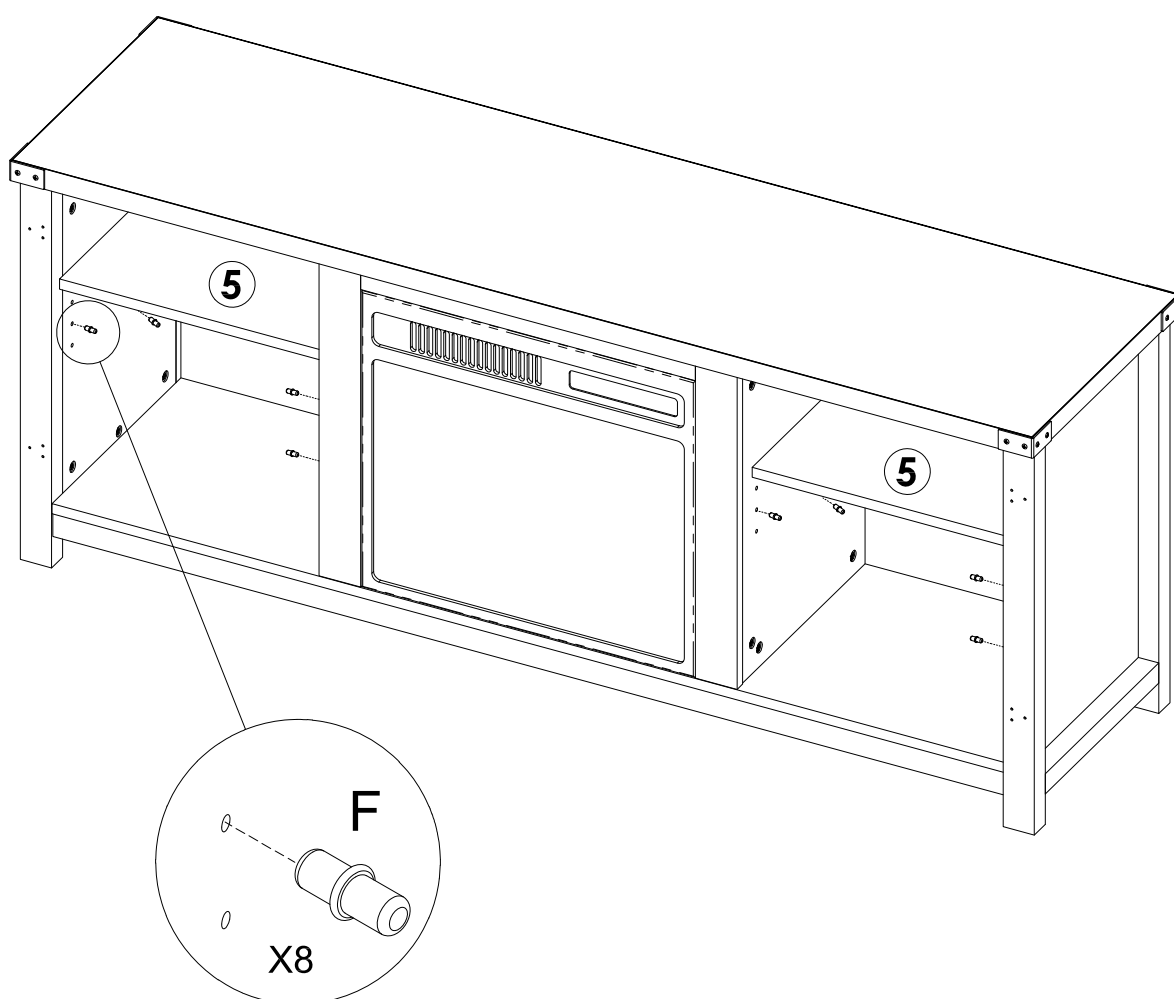
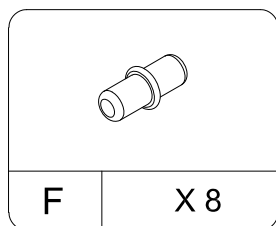

# STEP 16

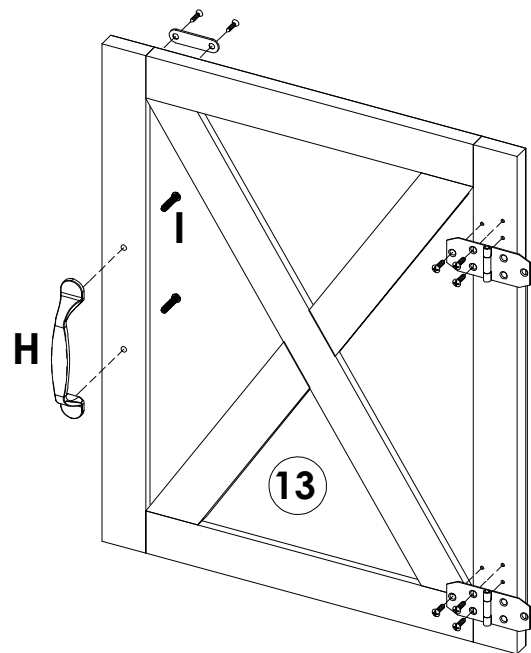
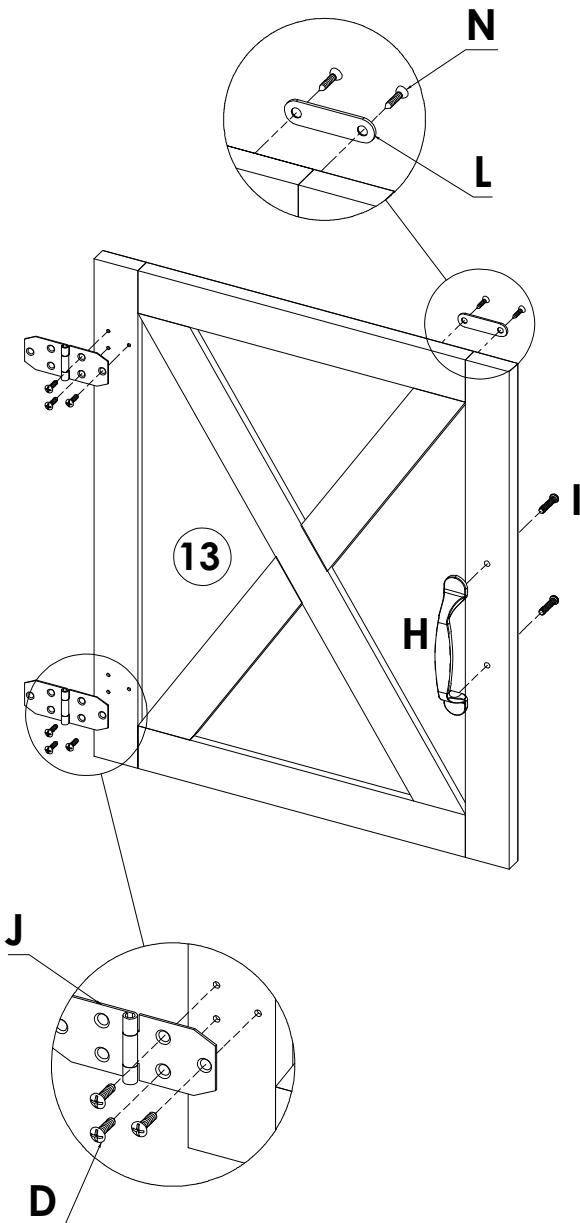
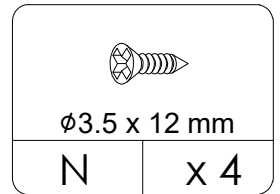
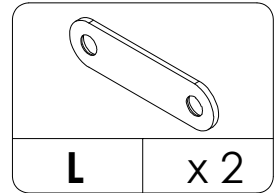
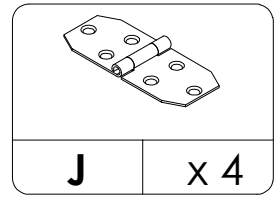
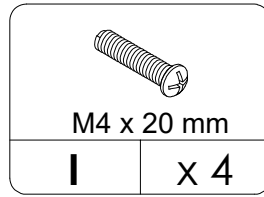
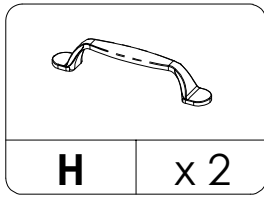
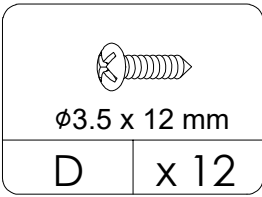

# STEP 17

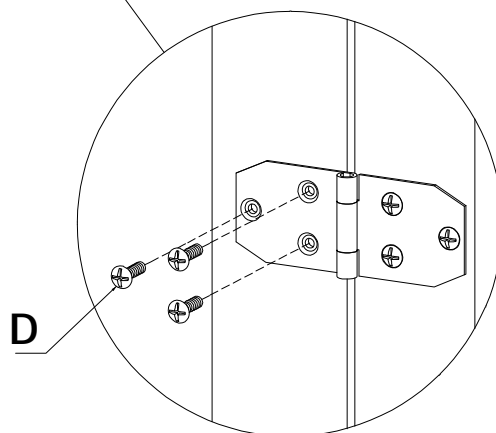
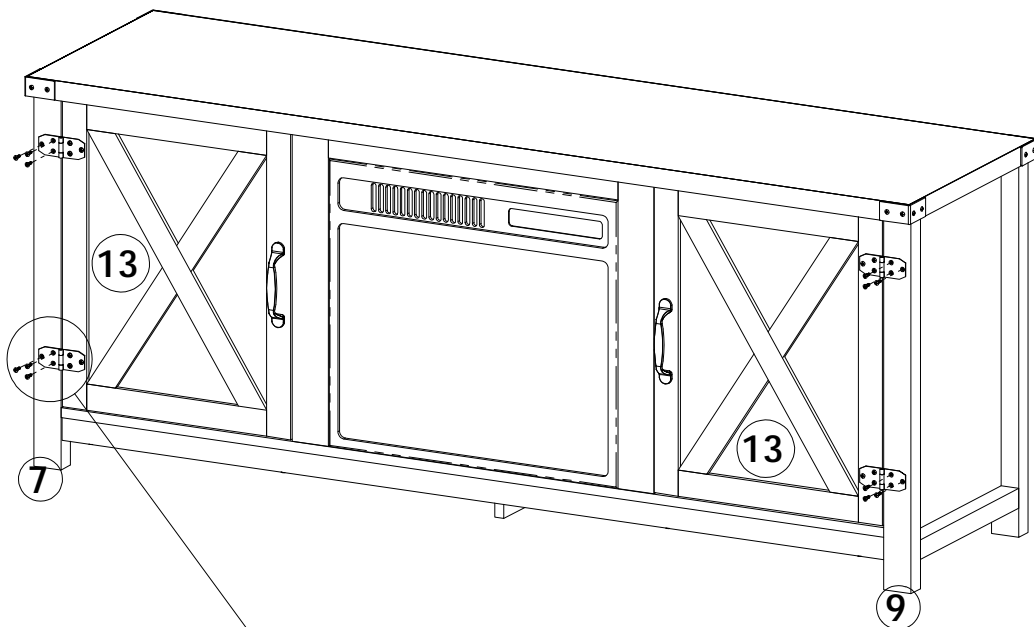
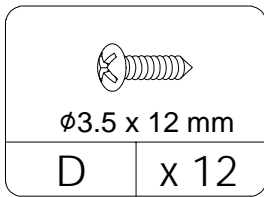

# STEP 18

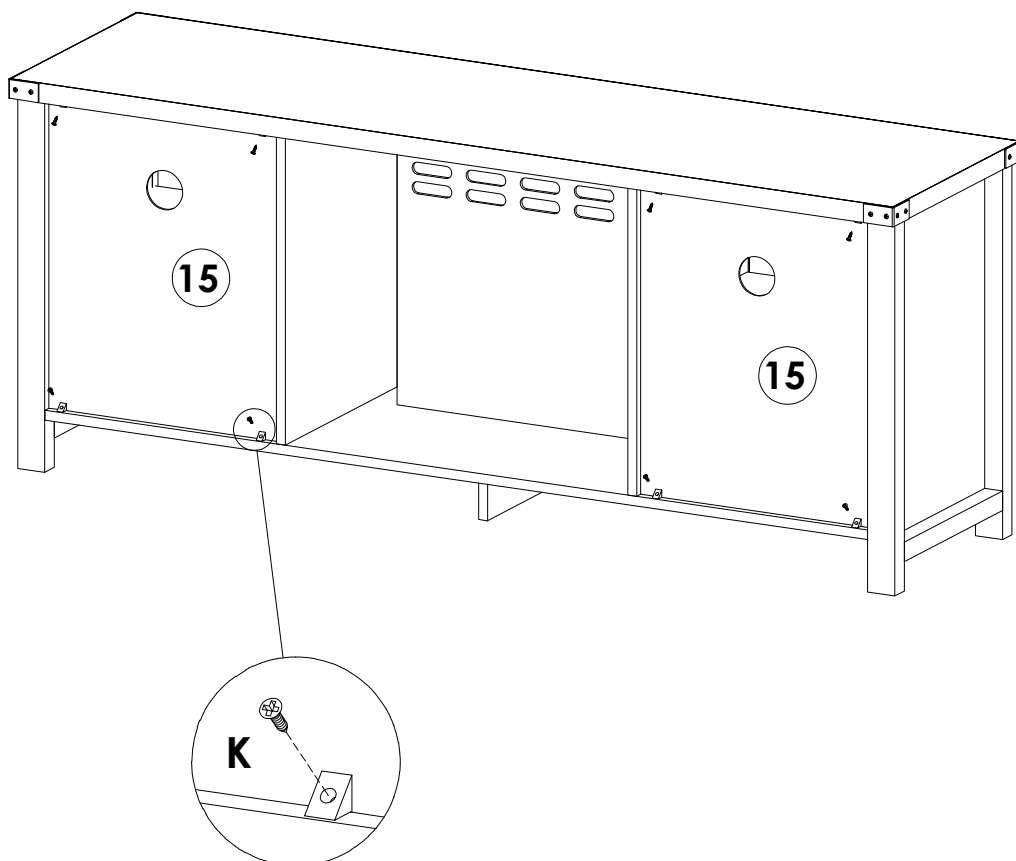
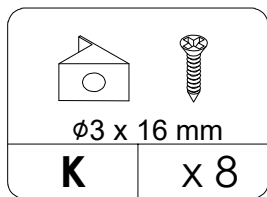

---

# FURNITURE CARE AND MAINTENANCE

## Particleboard

**Thank you for your purchase. We want your item to last as long as possible. To ensure the product gives you years of service, please refer to this care and maintenance guide.**



### MAINTENANCE

- **Tighten all bolts and screws again within the first 2 weeks of assembly**
- **Check the tightness of all bolts every 2 months, tighten them if necessary**



### CLEANING

- **Clean the surface of the PB(Particleboard) with a lightly dampened cloth.**
- **Small amount of mild soap can be used if necessary**
- **Dry the surface immediately after cleaning.**

- ⚠ **DO NOT use bleach or alcohol detergent to clean the surface.**
- ⚠ **DO NOT apply wood treatment on parts made with PB.**

**Particleboard will swell and distort when suffer .  
Make sure to dry the furniture immediately after cleaning**