



WCU55

55-Cup Commercial Coffee Urn



55-Cup Commercial Coffee Urn



MAIN FEATURES

- 55-cup capacity
- Brushed stainless steel housing
- Commercial grade, nonstick coated heater
- All-stainless steel construction, including internals and parts
- Dual-heater system for brewing and keeping warm at optimal temperatures; brews at 200°F and dispenses at approximately 185°F
- ON/OFF lighted Power switch and Ready indicator light
- Boil-dry protection with auto reset
- Limited One Year Warranty

ELECTRICAL

Voltage: 120

Frequency: 60 Hz

Watts: 1440

Amps: 12

Plug Type: NEMA 5-15P 

Cord Length: 3 feet



SALES FEATURES

The Waring® Commercial family of coffee urns is built for premium performance. Shorter brew times, extra-large capacities, and stainless construction styling make them perfect for special events and large commercial kitchens. A dual-heater system first brews coffee at a hotter temperature to ensure maximum flavor, then automatically shifts to the second heater to lower the heat and hold it at the ideal drinking temperature.



@waringcommercial

©2019 Waring Commercial
314 Ella T. Grasso Avenue, Torrington, CT 06790
Tel. 800-492-7464 • Fax 860-496-9008

waringcommercialproducts.com

WCU55



55-Cup Commercial Coffee Urn WCU55

DIMENSIONS

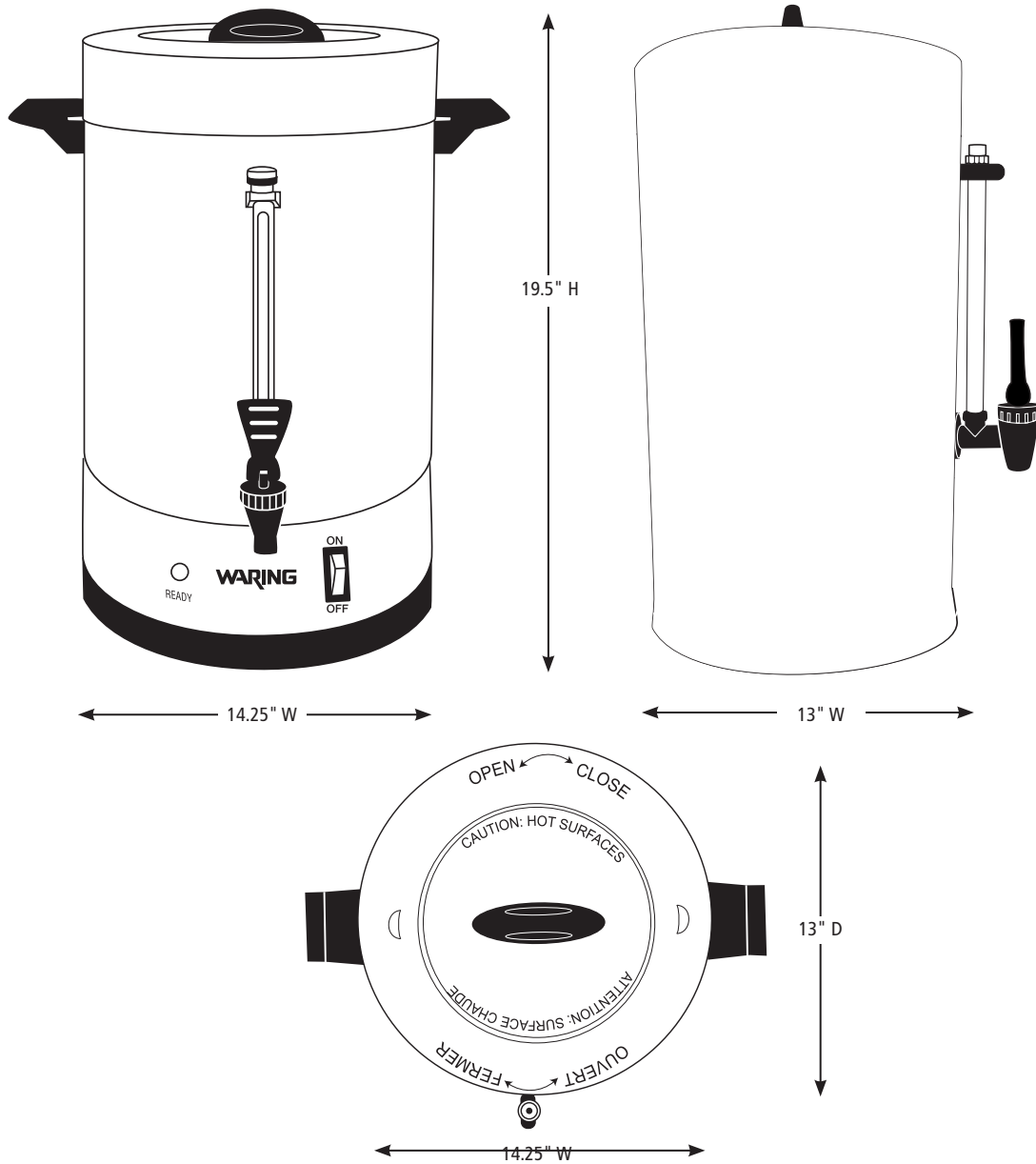

Out of Box Weight: 7 lb.

ORDERING INFORMATION	#STD. PKG.	GIFTBOX WEIGHT	CUBIC FEET	BOX DIMENSIONS D X W X H	UPC	CASE PKG.	MC WEIGHT	MC DIMENSIONS D X W X H	MBC
WCU55 – Commercial Coffee Urn	1	9.7	2.013	13.25" x 13.125" x 20"	040072068225	2	21.7	27" x 13.875" x 21"	10040072068222



@waringcommercial

©2019 Waring Commercial
314 Ella T. Grasso Avenue, Torrington, CT 06790
Tel. 800-492-7464 • Fax 860-496-9008

waringcommercialproducts.com

19WC059780 REV 08/19