

**TVS-LTM-001-V2**

**TV Stand Media Console**

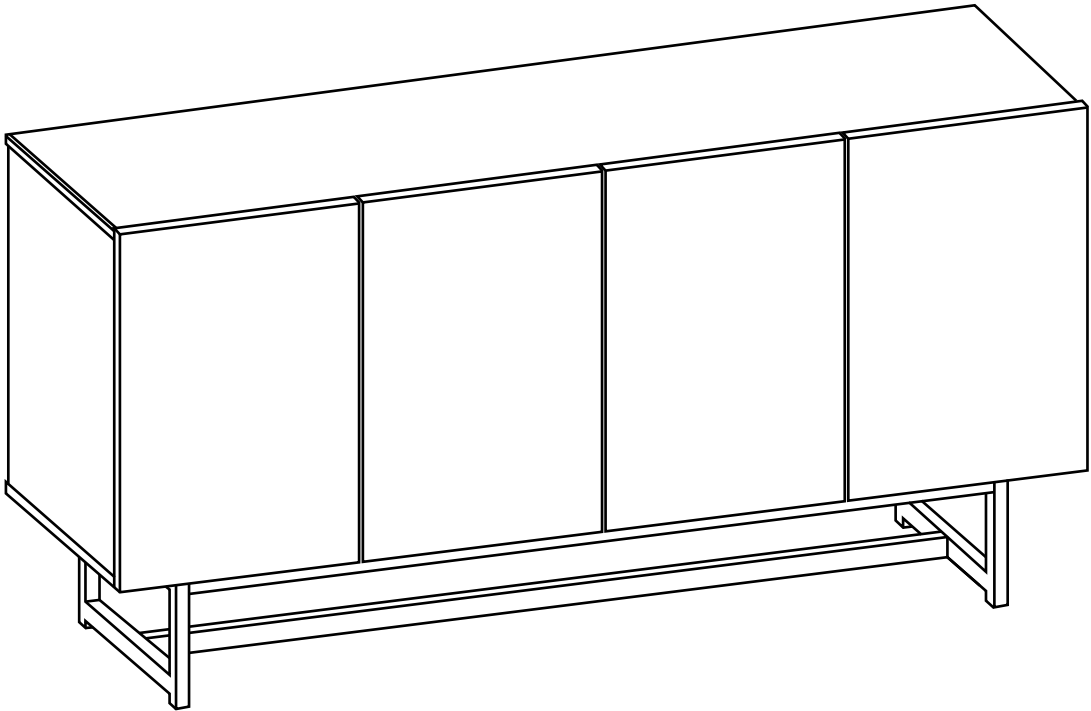

**ASSEMBLY INSTRUCTION**

**ADULT ASSEMBLY REQUIRED**

**THE PRODUCT MAY RECOMMENDED  
ASSEMBLING BY MORE THAN ONE PERSON.**

**PLEASE ASK FOR ASSISTANCE AT YOUR  
CONVENIENCE BEFORE ASSEMBLING.**

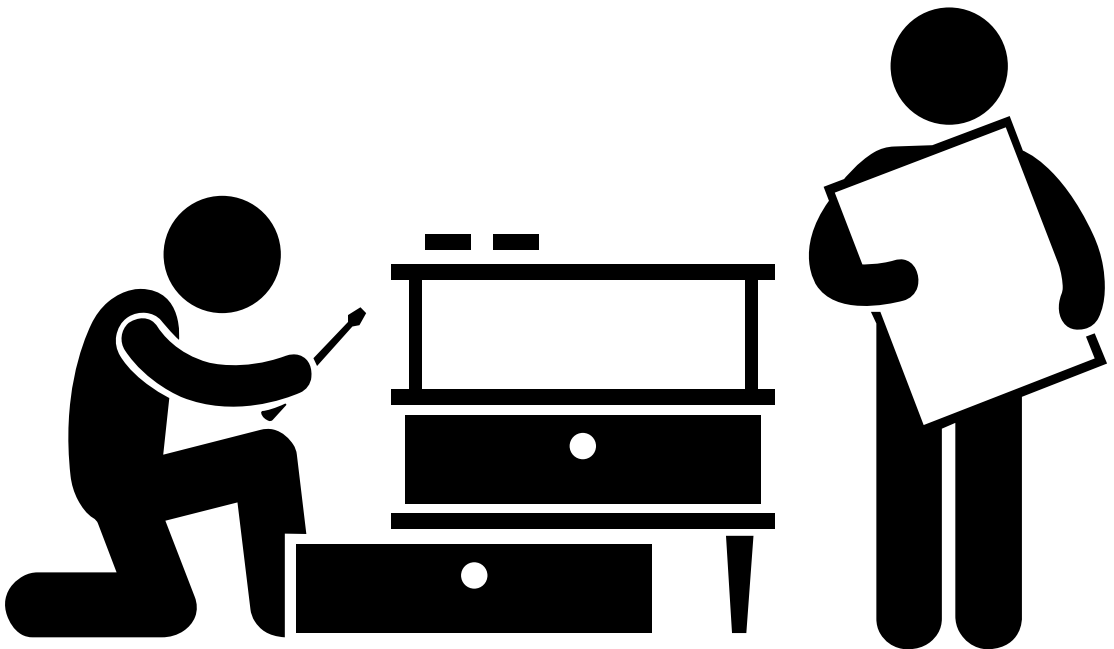

# Before You Start

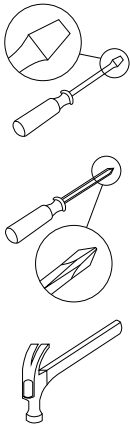

- Carefully read each step and follow the proper order
- Separate and count all parts and hardware
- Ensure you have enough space for assembly
- Have the following tools: Flat Head Screwdriver #2 Phillips Head Screwdriver and Hammer
- Caution: If using a power drill or screwdriver, slow down and stop when the screw is tight to avoid stripping

Failure to do so may result in stripping the screw



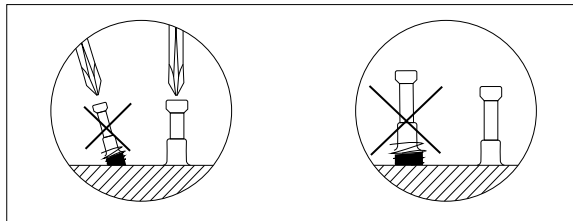



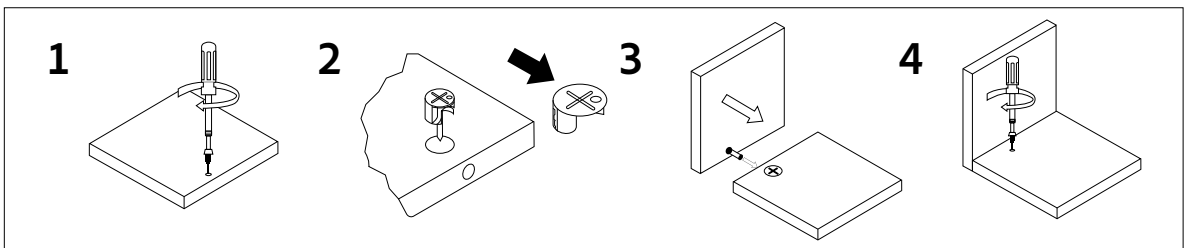



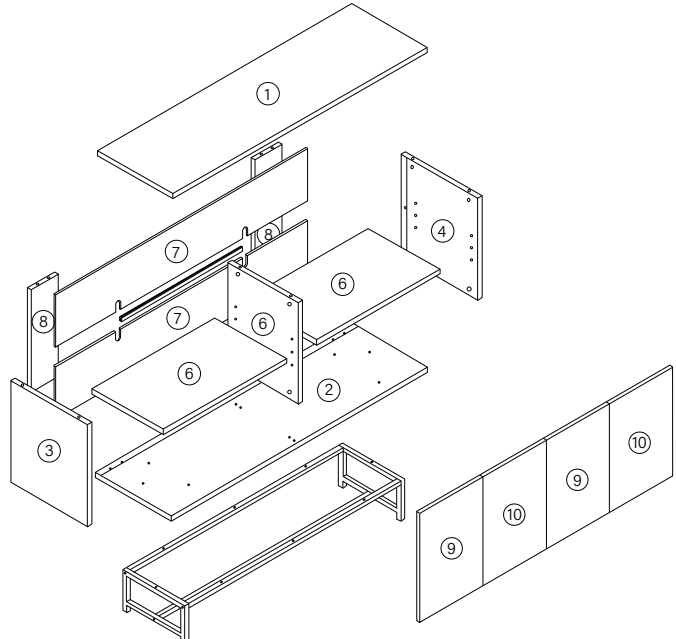

# Cam Lock Fastening System



Ensure screws are evenly tightened and assembled vertically



# Parts & Hardware

		
A×22 pcs	I×8 pcs	
		
B×22 pcs	J×1 pcs	
		
C×56 pcs	K×1 pcs	
		
D×4 pcs	Wood Plug × 13 pcs	
		
E×4 pcs		
		
F×8 pcs		
		
G×4 pcs		
		
H×8 pcs		

# Step 1

H×8

I×6

K×1

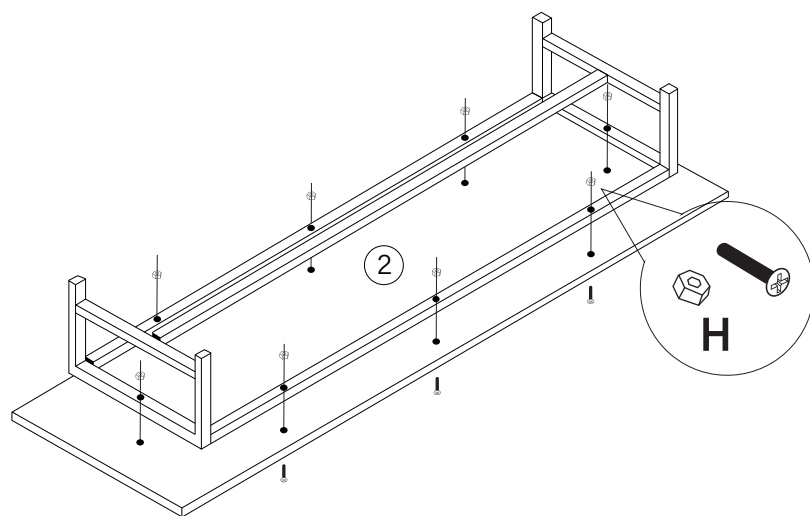
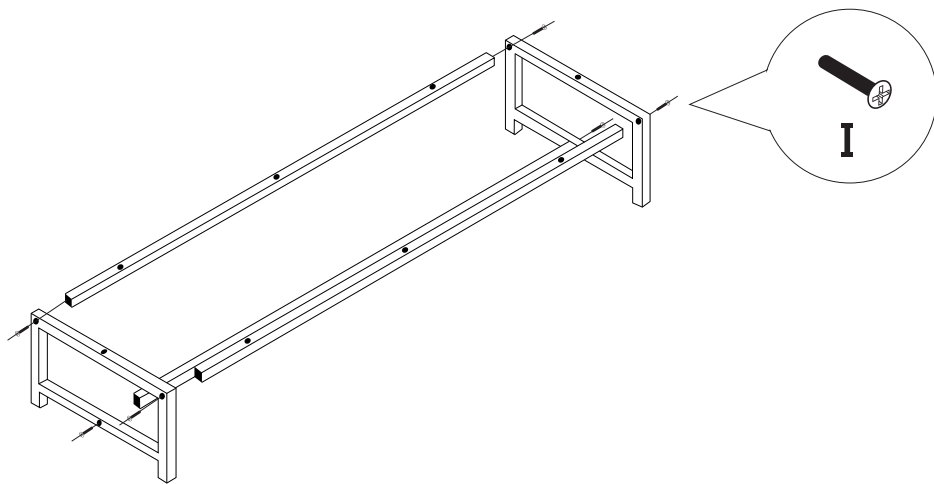

# Step 2

A×12

B×12

Wood Plug × 12

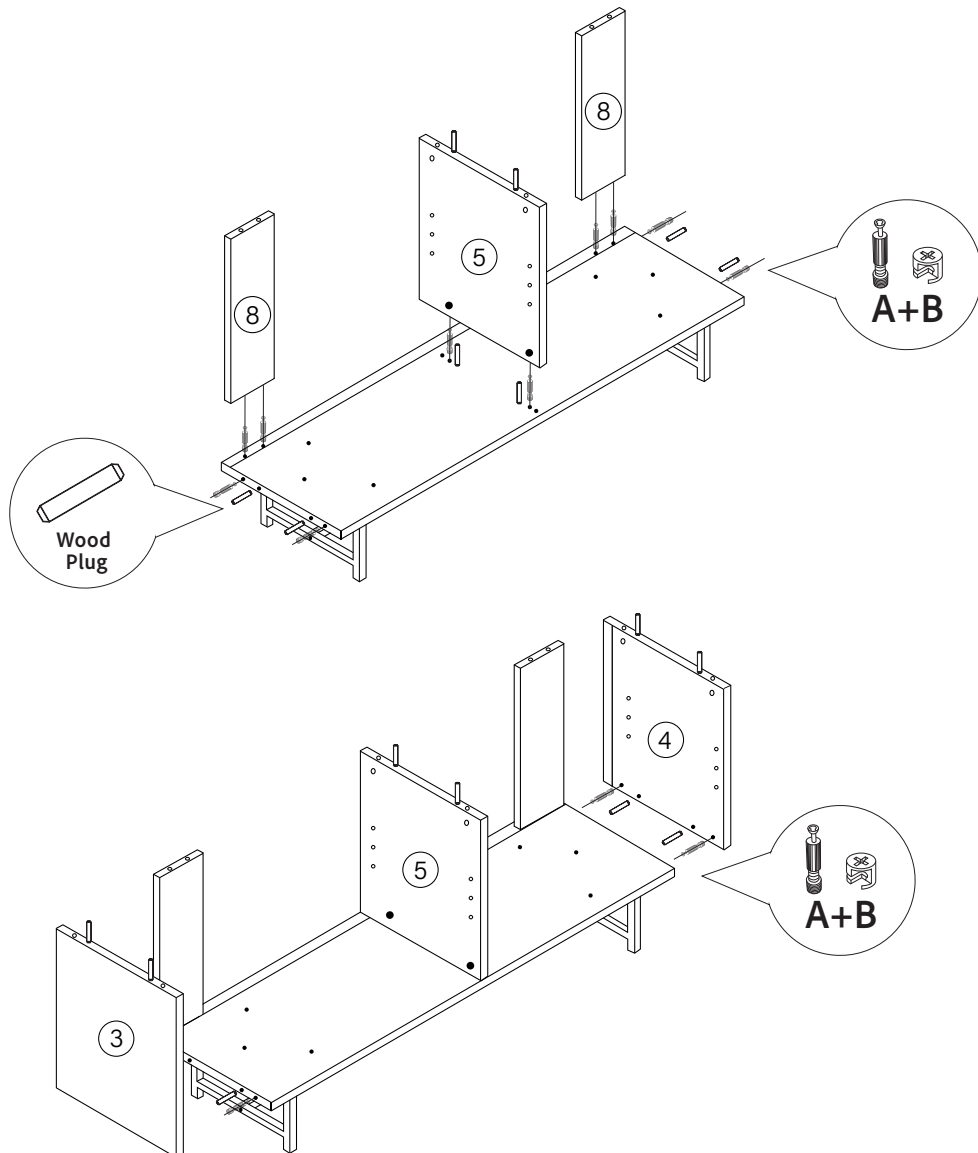

# Step 3

J×1

A×10

B×10

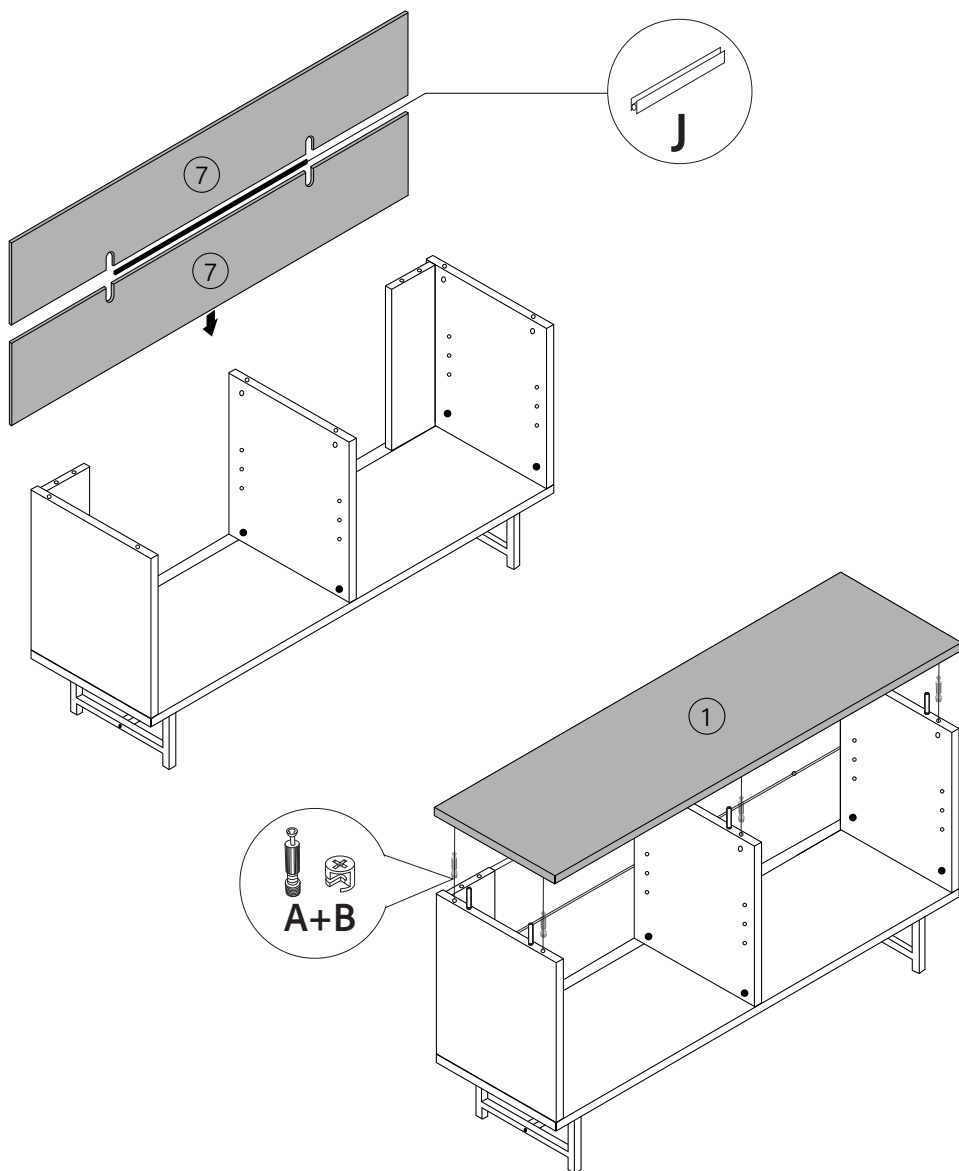

# Step 4

G×4  
E×4

F×8  
C×56

D×4

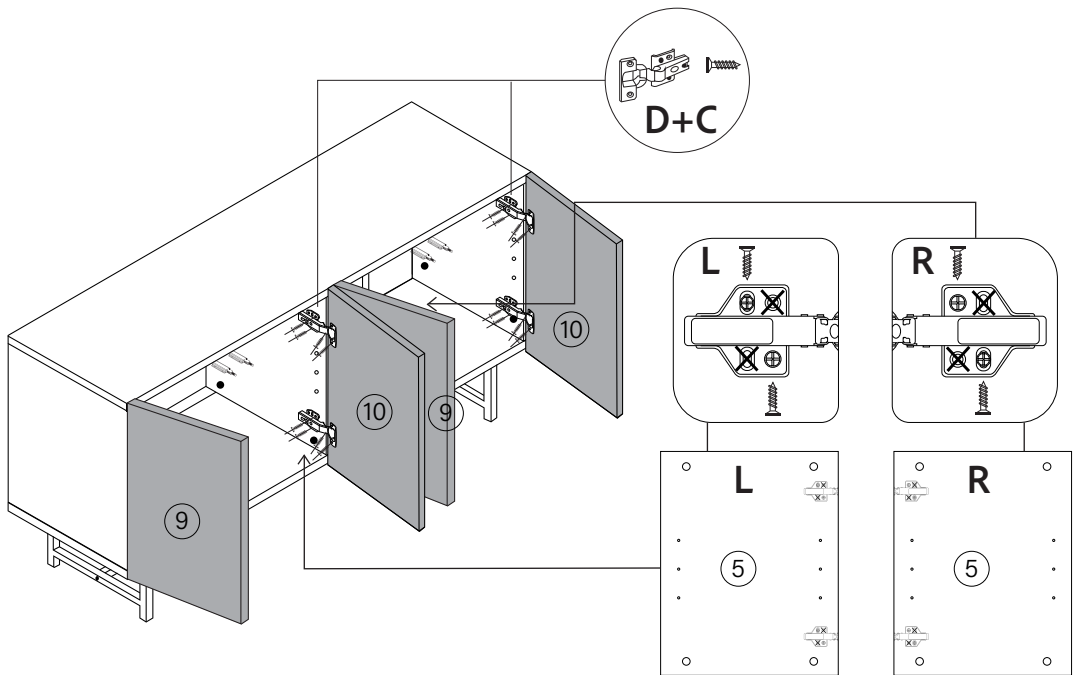
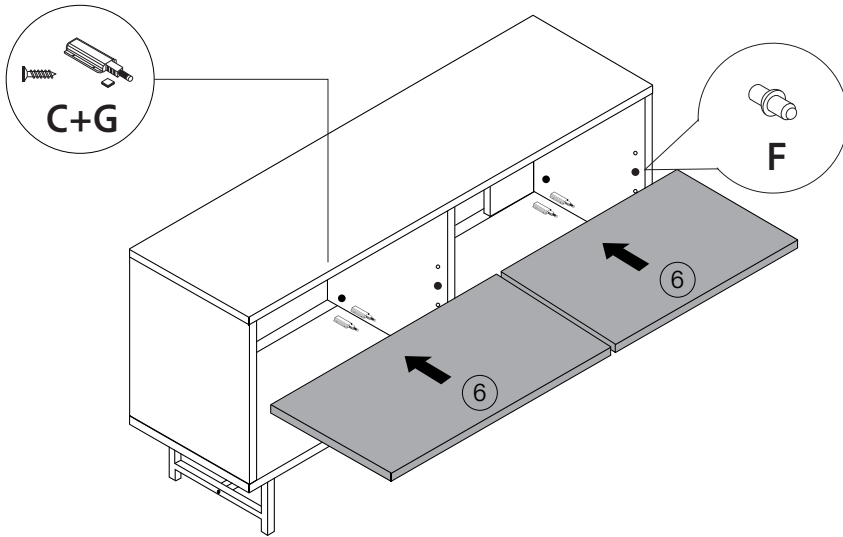

# Maximum Load Capacity

This unit is designed to support the listed maximum loads. Exceeding these limits may result in sagging, instability, collapse, or serious injury

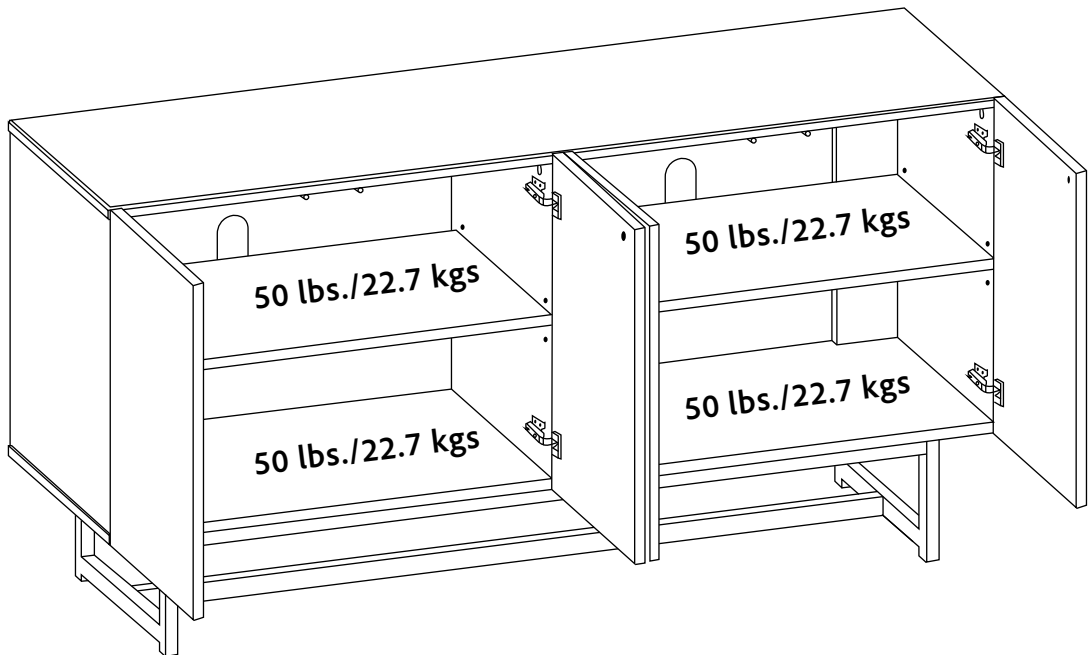

## WARNING

Ensure all items are removed before moving the unit. Lift with a team: do not drag or push. Failure to follow these instructions may result in instability, collapse, or serious injury.