

INSTALLATION NOTE MANUAL

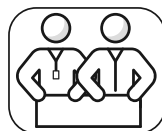
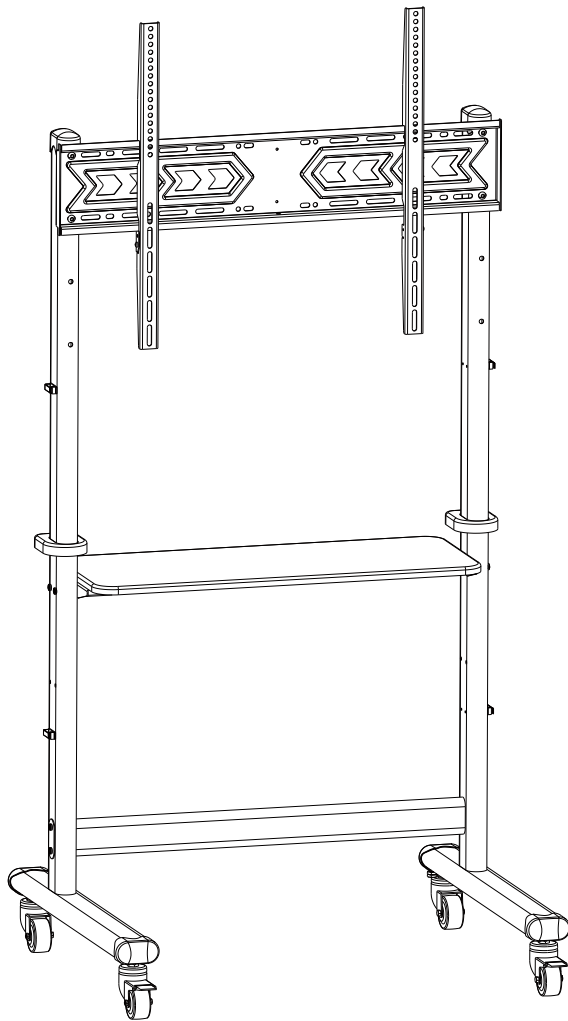

Installation requires 2 people

THANK YOU FOR PURCHASING

SERVICE CARD

We strive to make sure each furniture you received is perfect, all parts and hardware in the parts list are included in your package. However, if any lack or damaged of components, please do not return the product directly to any local store, feel free to contact us, we will do our best to solve your problem and send the replacement parts to you as soon as possible from our local customer service center.

**Please provide following information before you contact us.
Your detail information will help us to bring you a much faster and effective service.
Thank you for your kindly understanding and patience!**

1. **Order ID.** -in your order details in online shopping platform.
Model No. - lower left corner on manual first page, or SKU no. in order details.
Series No. - lower right corner on manual first page.
2. Shopping platform you place the order
3. Inform your problem and advices to us to make good solutions.

NOTICE



Please read this assembly manual carefully and make sure you have all the parts in the list before you begin to install.
Meanwhile, please keep this assembly manual for future reference.



Please move the furniture gently with 2 persons.



Please protect the furniture by placing all parts on a soft surface during assembly.



Please don't place very warm/cold objects on top of any surface, clean immediately with microfiber cleaning cloths/towels if any liquids on the surface.
Never use multi-surface furniture polish spray or cleaner.
Do not touch the surface with a hard/acute object that may cause scratch or broken.



Adult supervision required. Keep little parts of furniture far away from the children.

Do not allow children to climb onto the furniture.
Improper use or incorrect assembly may cause death or serious injury.
Use extra safety straps to ensure the best tip-over protection.

Do not use this product for any purpose or in any configuration not explicitly specified in this instruction.

We hereby disclaim any liability for injury or damage arising from incorrect assembly, incorrect mounting, or incorrect use of this product.

PRODUCT DESCRIPTION

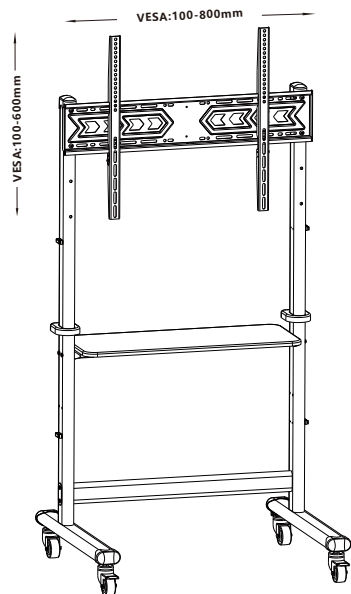

PARTS LIST パーツリスト

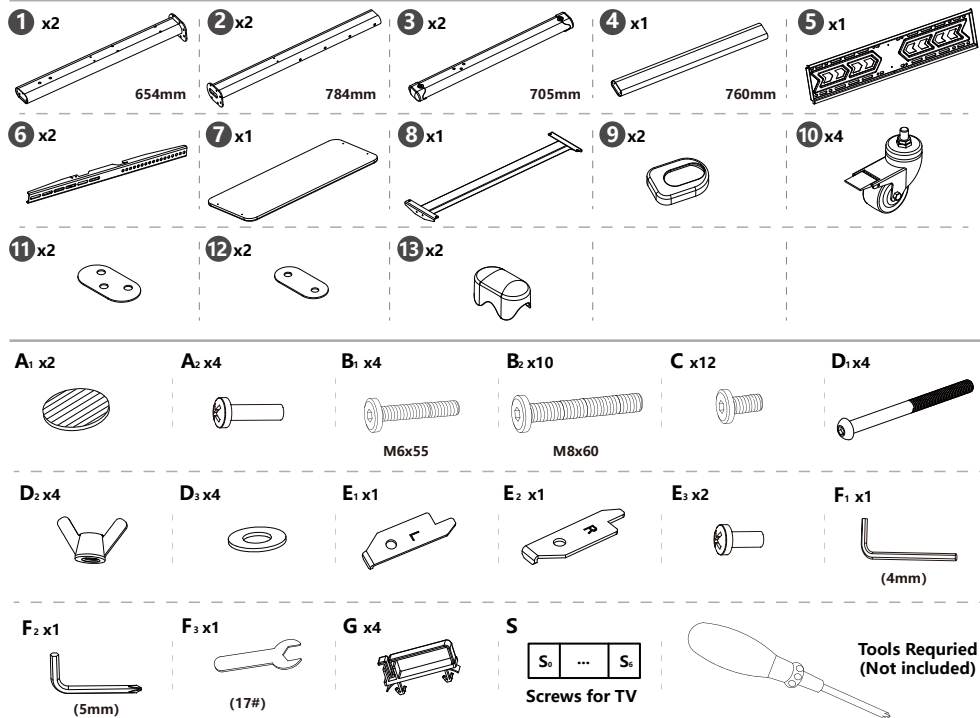

MEASURE VESA FOR YOUR TV

1. What does the VESA standard mean?

The VESA standard is a standard for attaching flat screens / LCD / monitors / televisions to monitor mounts or TV mounts.

Prerequisite is that both the monitor / TV and the monitor mount have the same VESA standard.

2. Look at the back of your TV/monitor for threaded holes.

Measure the horizontal distance **W** and vertical distance **H** of the screw holes (center to center).

W x **H** should comply with the VESA standard of TV stand listed in below sheet.

Notice: If the TV/monitor is not compatible with VESA, it can still be attached to the desired bracket by using VESA Adapters(not included and should extra buy).

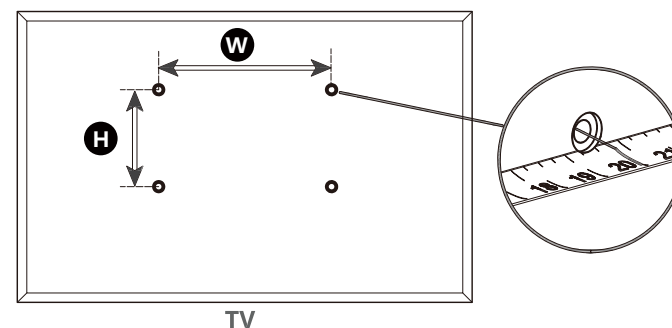







Units:mm			Units: inch		
W	x	H	W	x	H
100	x	100	4.0	x	4.0
200	x	100	7.9	x	4.0
200	x	200	7.9	x	7.9
300	x	200	11.8	x	7.9
300	x	300	11.8	x	11.8
400	x	300	15.7	x	11.8
400	x	200	15.7	x	7.9
400	x	400	15.7	x	15.7
600	x	200	23.6	x	7.9
600	x	400	23.6	x	15.7
800	x	200	31.5	x	7.9
800	x	400	31.5	x	15.7
800	x	600	31.5	x	23.6

VESA standard of TV STAND

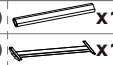

Please check the weight of your display, it should be less than 200lbs/ 90kgs.

1



1	 x2	4	 x1	12	 x2
B	B₁  x4	B	B₂  x4	F	F₁  x1
				F	F₂  x1

As shown in below diagrams, place the screw mounting holes for part **3** facing upwards, install part **3** and part **4** respectively using screw **B₁** and **B₂** .

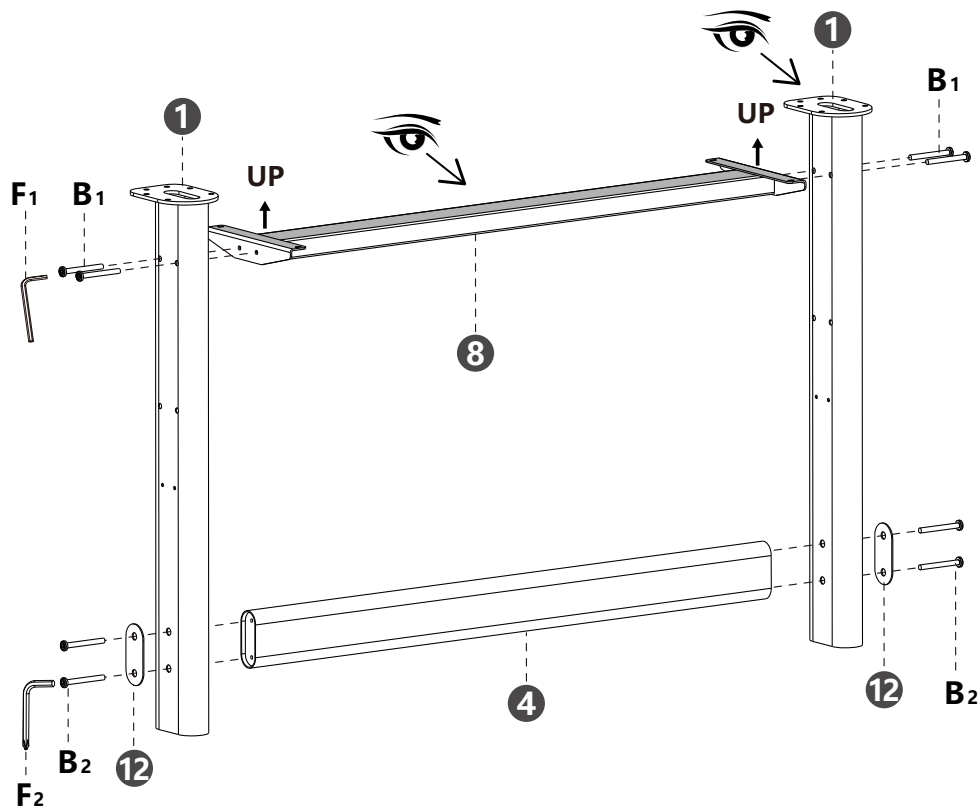
Notice- Install part **1** in the same direction.
Tighten all screws after installing them in the right holes.



2

3	 x2	10	 x4	11	 x2
F	F₁  x1	B	B₂  x6	F	F₂  x1

1. Install part **3**, part **11** in sequence on part **1** , then secure with screw **B₂** .
2. Assemble wheel **10** while keeping bottom part **3** level with floor surface, then tighten screw **Z** counterclockwise.

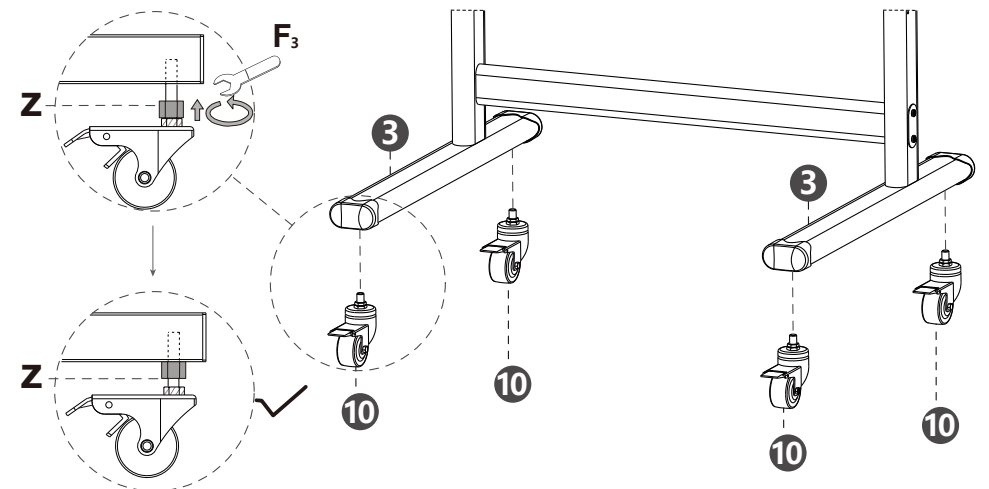
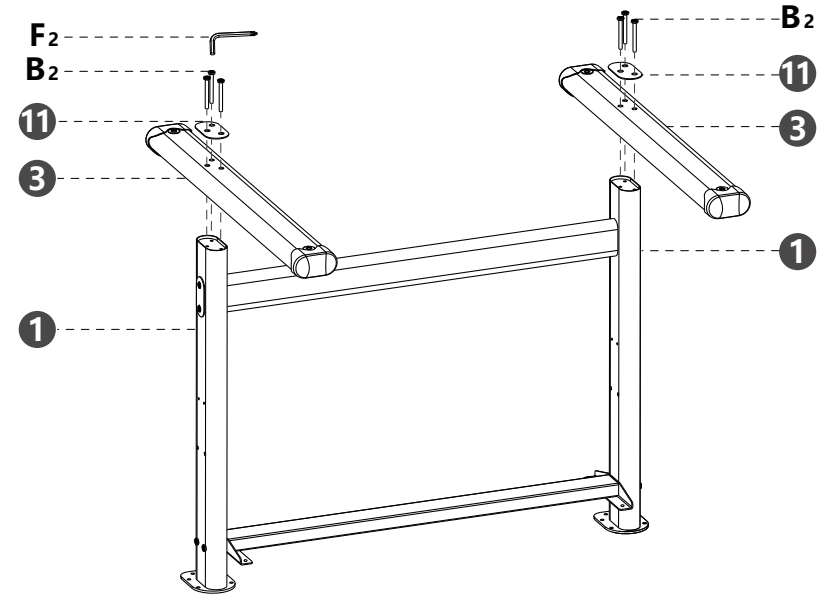

3

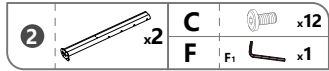

Install part **2** on part **1** and secure with screw **C** .

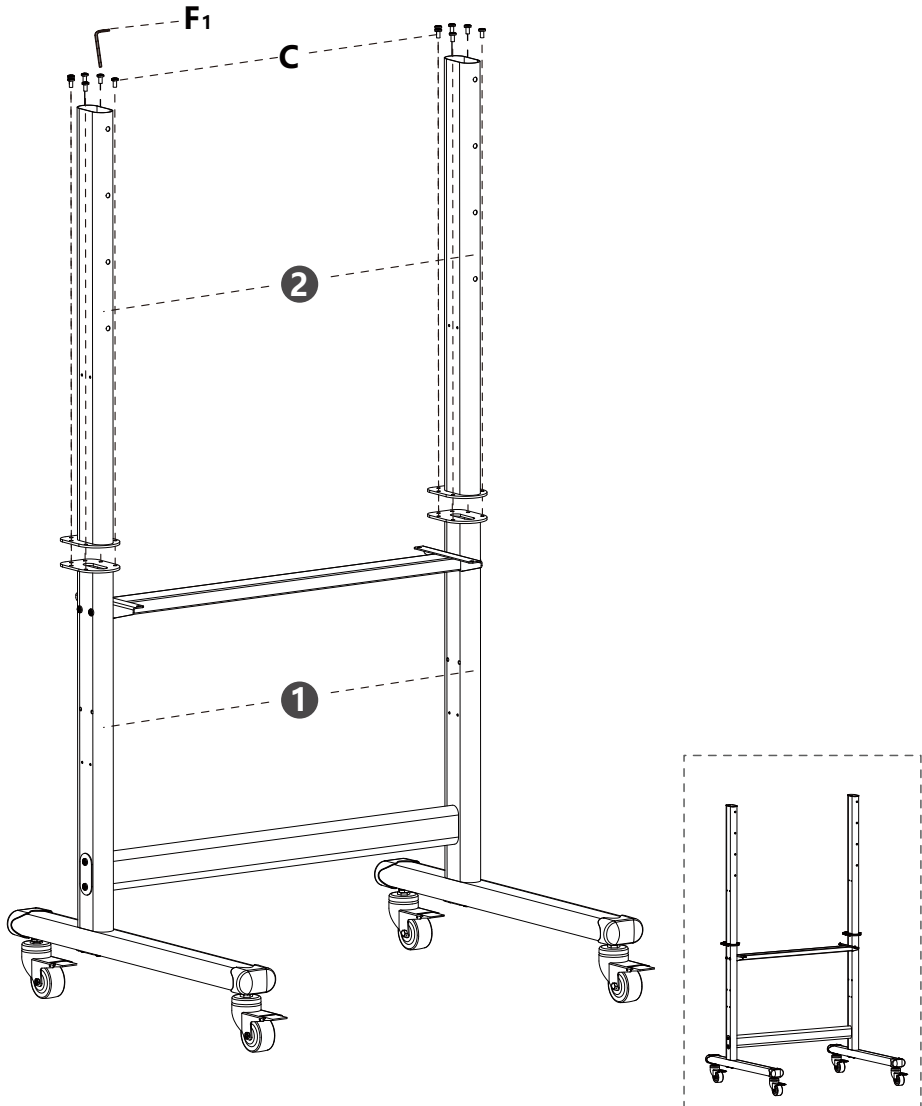

4



1. Slide part **9** down from the top of part **2** , press down to fasten part **9** when it slides to the connection of part **1** and part **2** .
 2. Cover part **13** on top of part **2** .

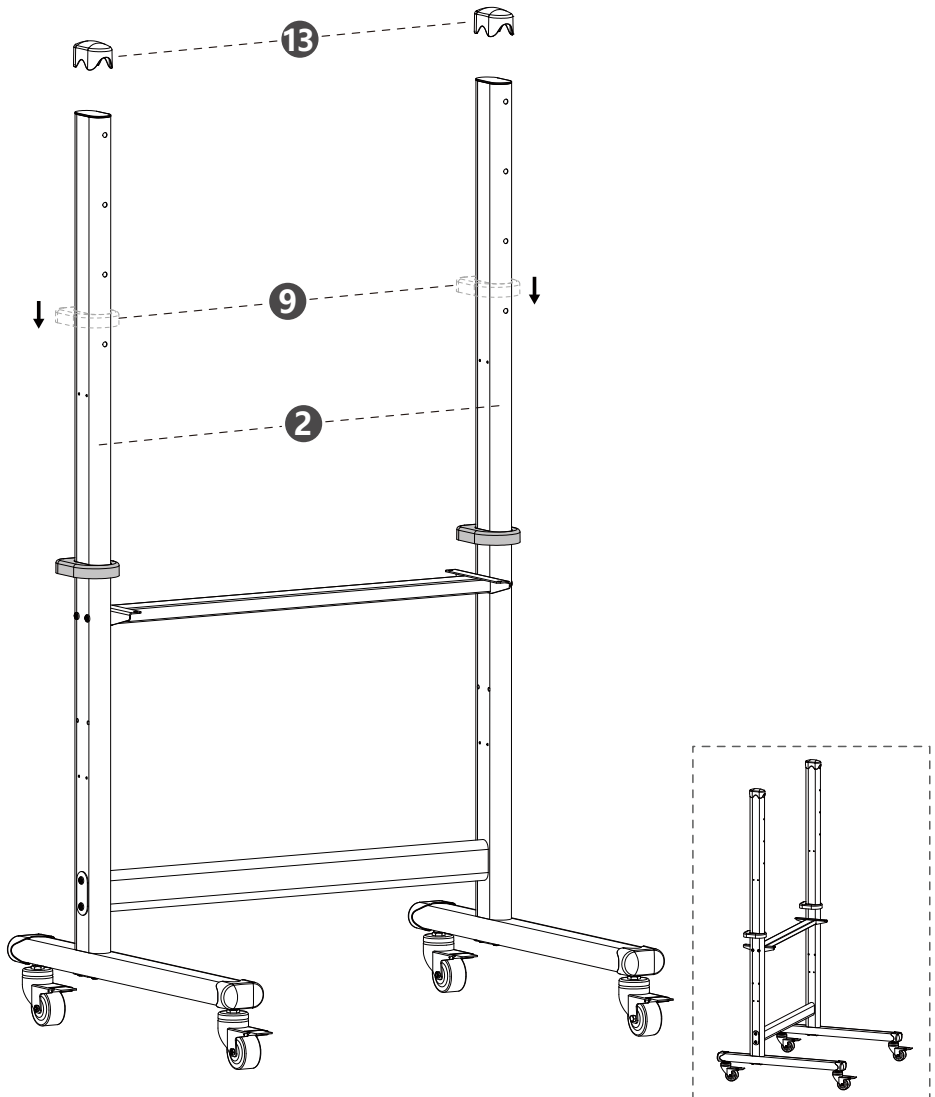

5

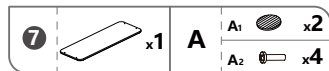

1. Stick **A1** to top face of part **8** .
2. Fix shelf **7** to part **8** and secure with screw **A2** .

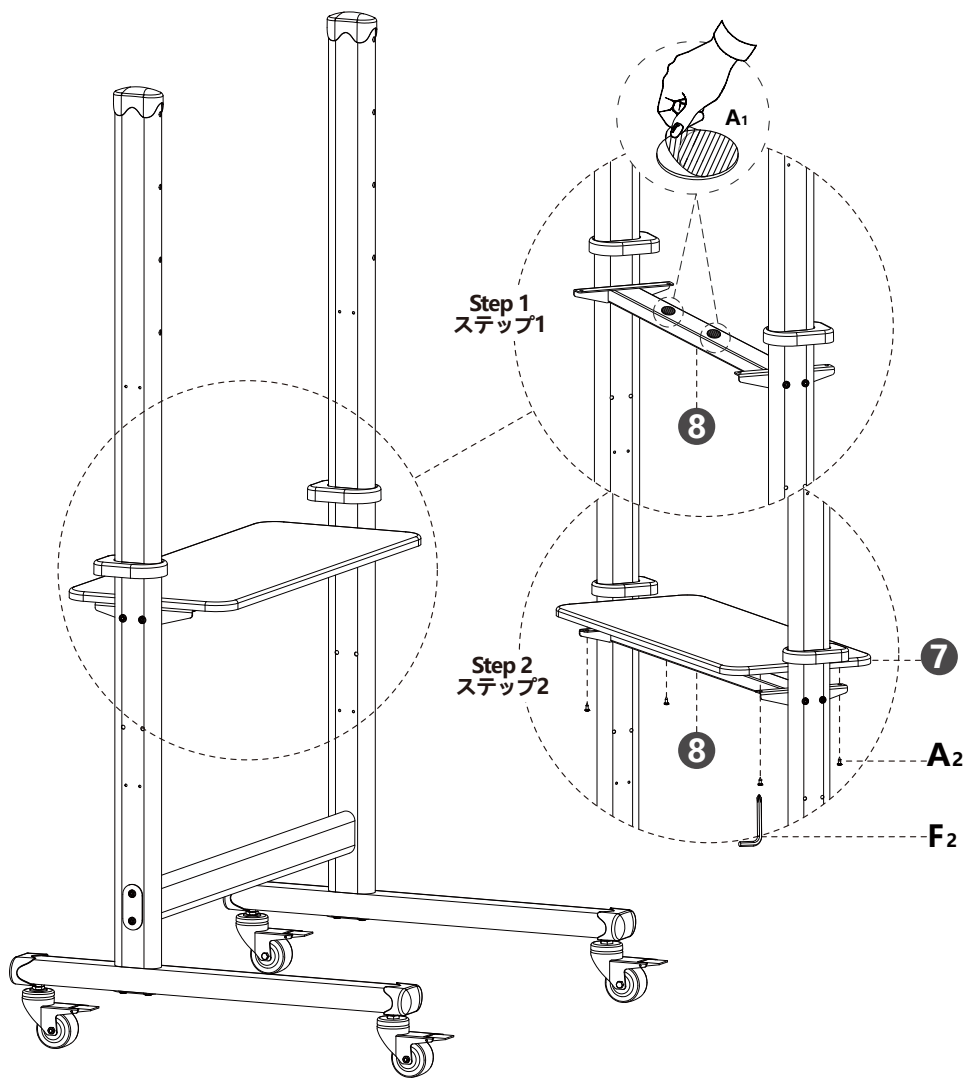

6

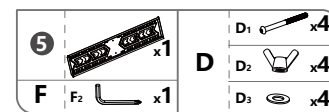

- Levelling part **5** then fully tighten screws **D1** .

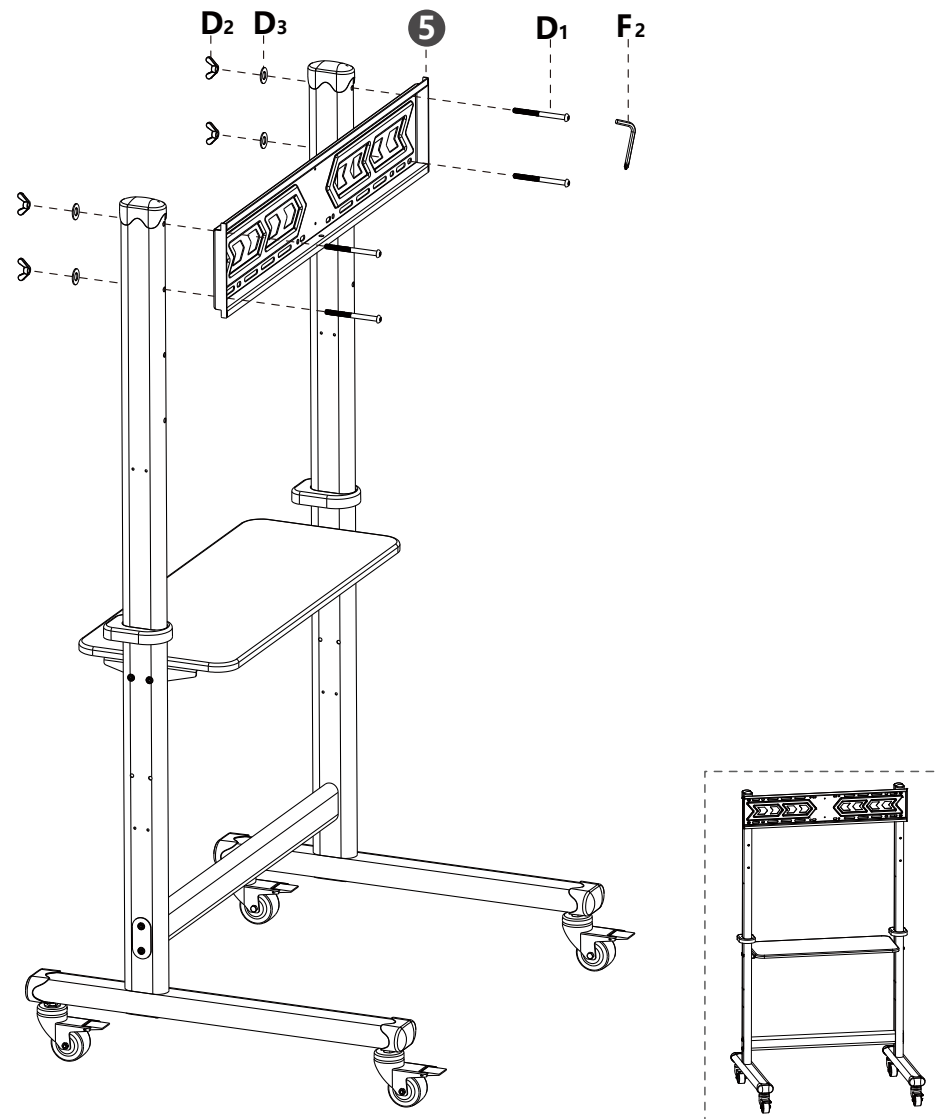

7

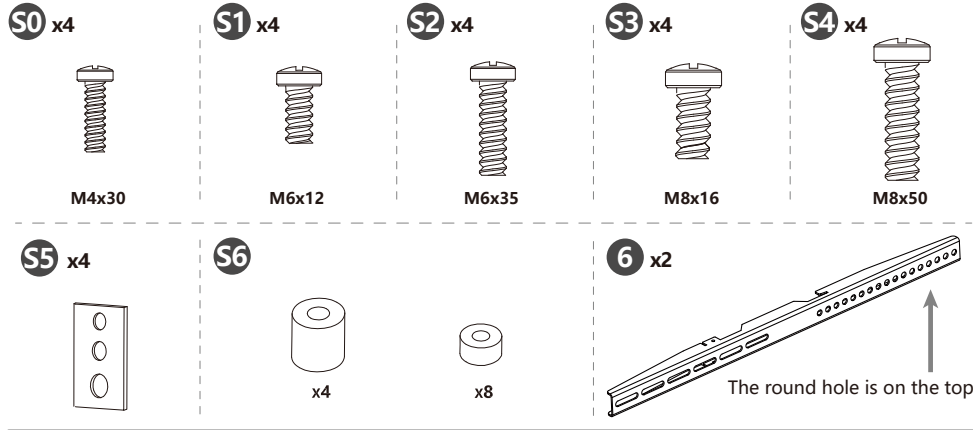

STEP 1 Select TV Screw Diameter

Please make sure the diameter of the screw **S0-S4** are suitable for your TV.

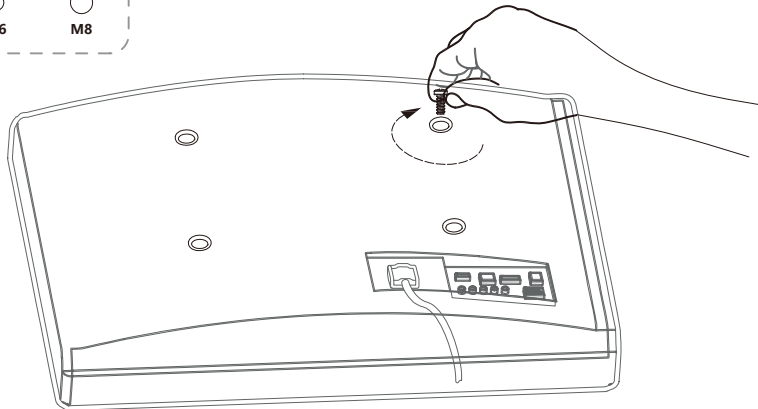
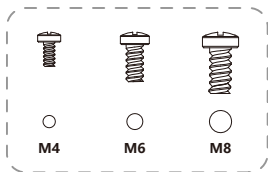

STEP 2 Select TV Screw Length

When attaching brackets to the TV, be careful not to over tighten screws and be sure that screws don't bottom out in the mounting holes. Please make sure the length of thread engagement at least 6 turns or 5/16 inch (8mm).

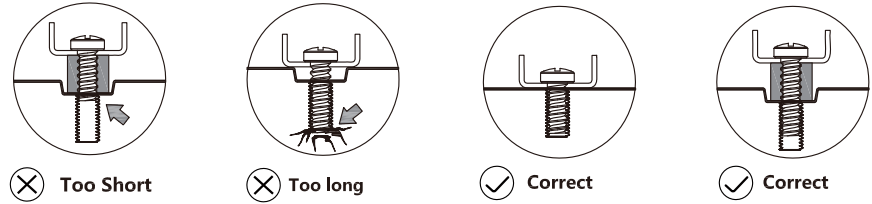

STEP 3 Select installation method according to TV

Option 1 (For Flat Back TV)

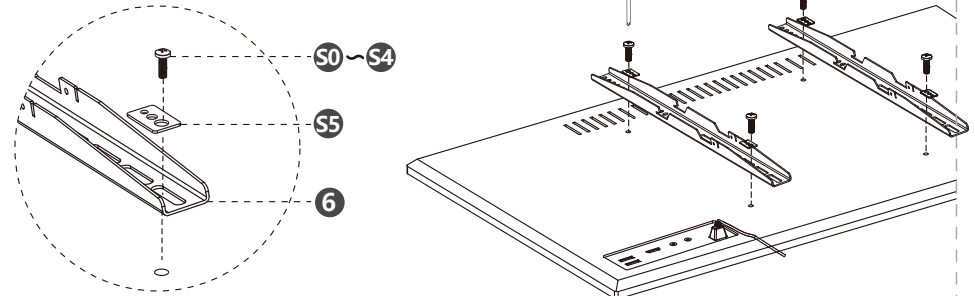

Option 2 (For Round Back TV or Curved TV)

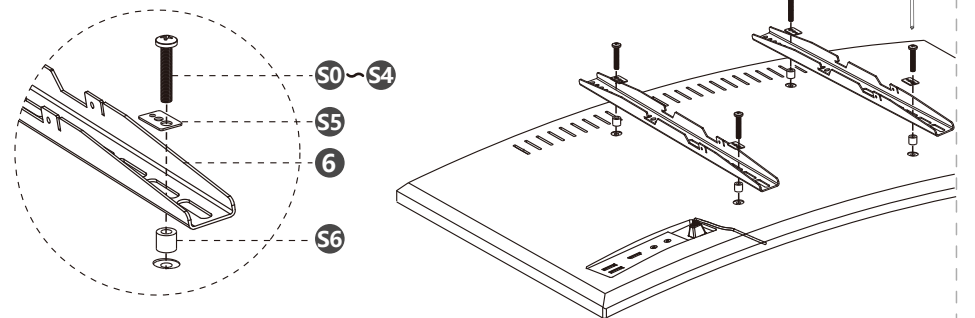

1. Install cable management clip **G** to the side holes of part **1** and part **2**, select the inside or outside installation according to the use requirements.
2. Open the buckle of cable management clip **G**, put the cables and wires into it, then close the buckle to fix, so that keep the stand tidy.

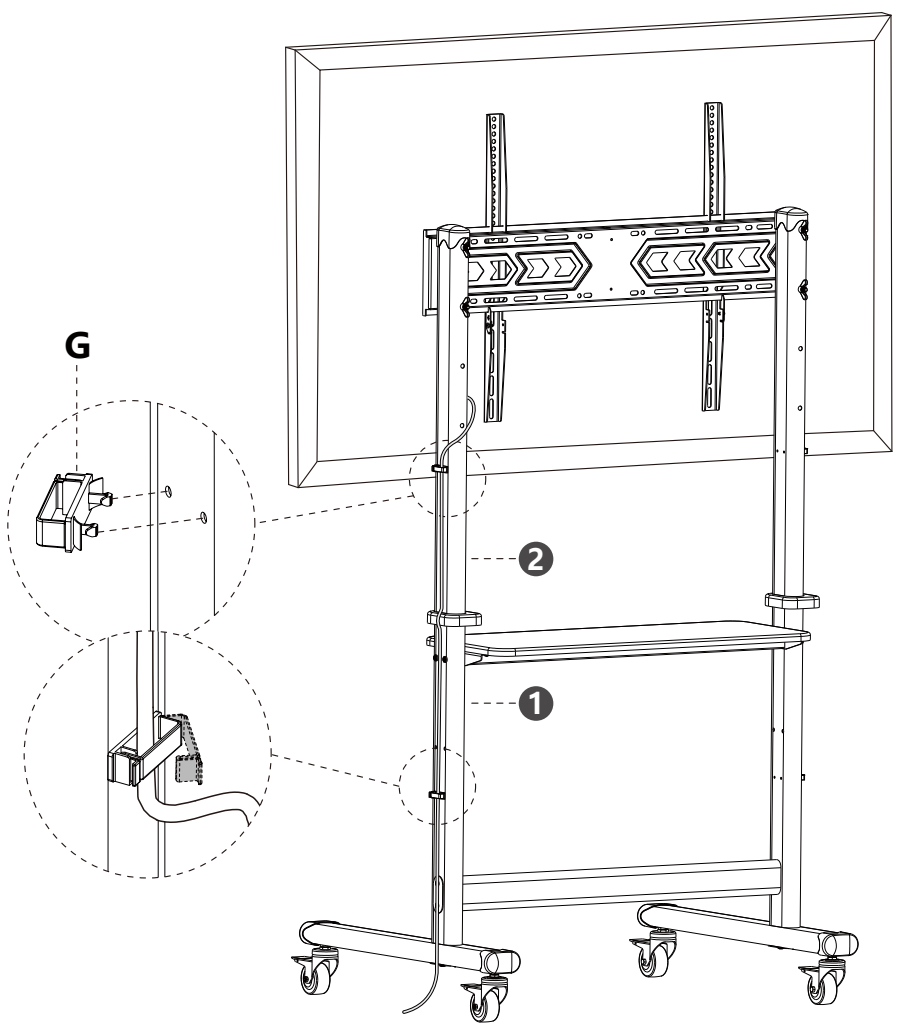

Shelf Position Adjustment

The front and rear positions of shelf **7** can be adjusted 42.5mm for each level according to the requirements of use.

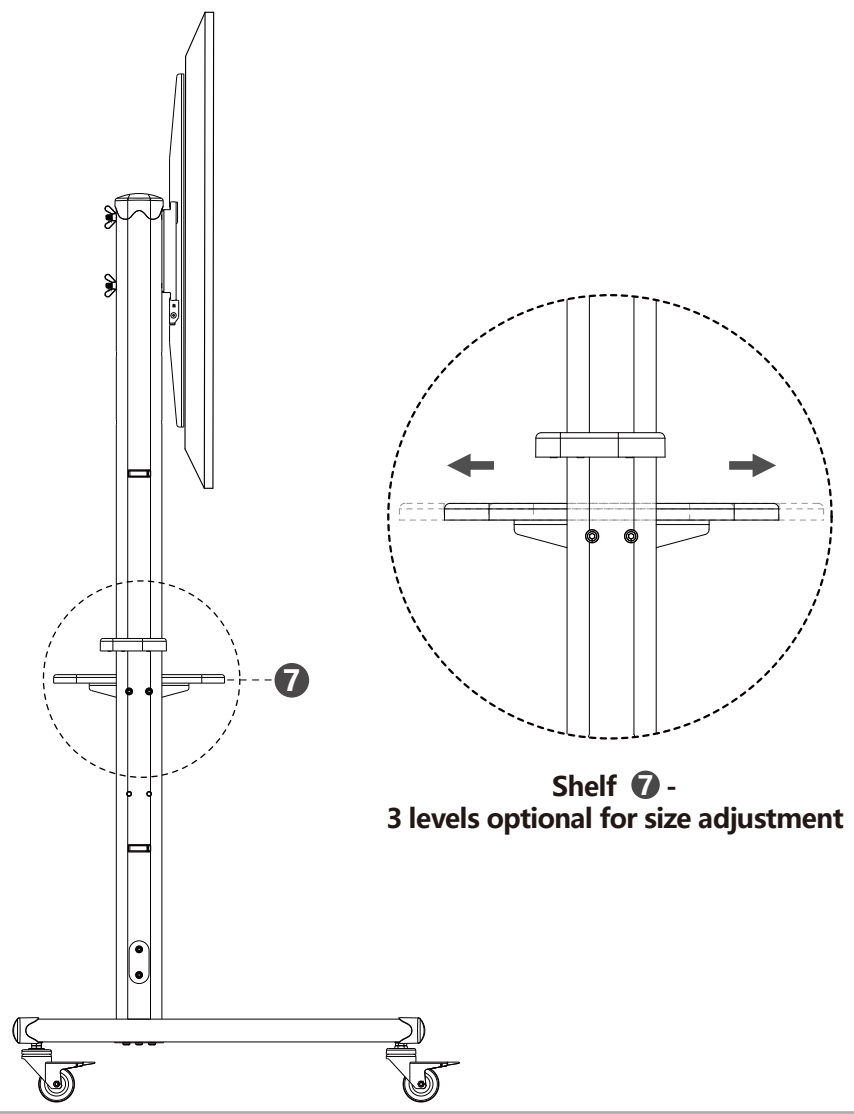

Shelf 7 -
3 levels optional for size adjustment

Stand Height Adjustment - Shelf /Brackets

1. Please take off the TV from the stand then select the proper height by yourself.
2. Shelf ⑧ height adjustment is 180mm(7 inch) per level, and TV plate ⑤ height adjustment is 120mm(4.7 inch) per level
3. Attach the tv to the tv plate ⑤ again, assemble safety lock E₁, E₂ and tighten screws E₃ on the bottom of brackets to secure the tv to the stand.

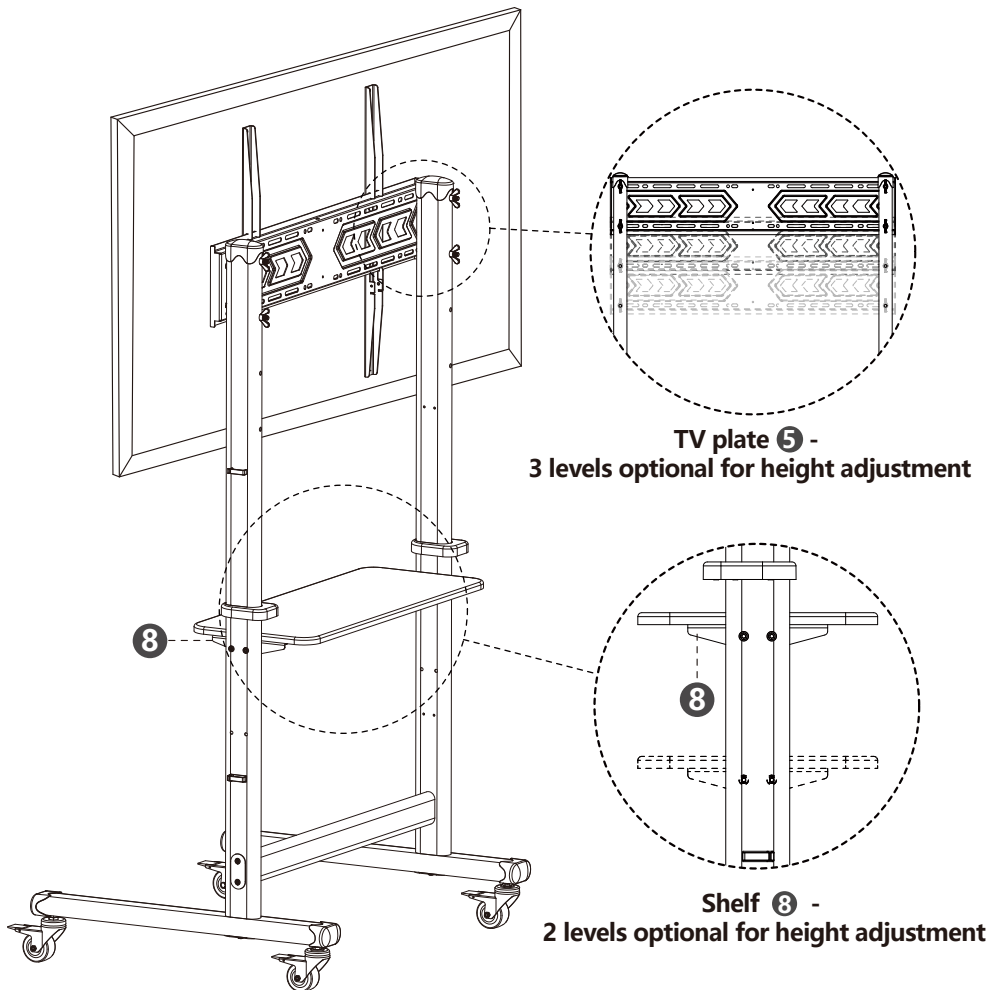

EASILY MOVE

You can move the stand around easily, please make sure all wheels are unlocked during the movement, and make sure your hand is on reasonable position as below shown to avoid wrong operation that result the stand falling over.

Please take off the TV and devices If you need to move the stand for long distances.

Please don't move this stand on the carpet or unlevel ground.

