

Assembly Manual

Love Seat

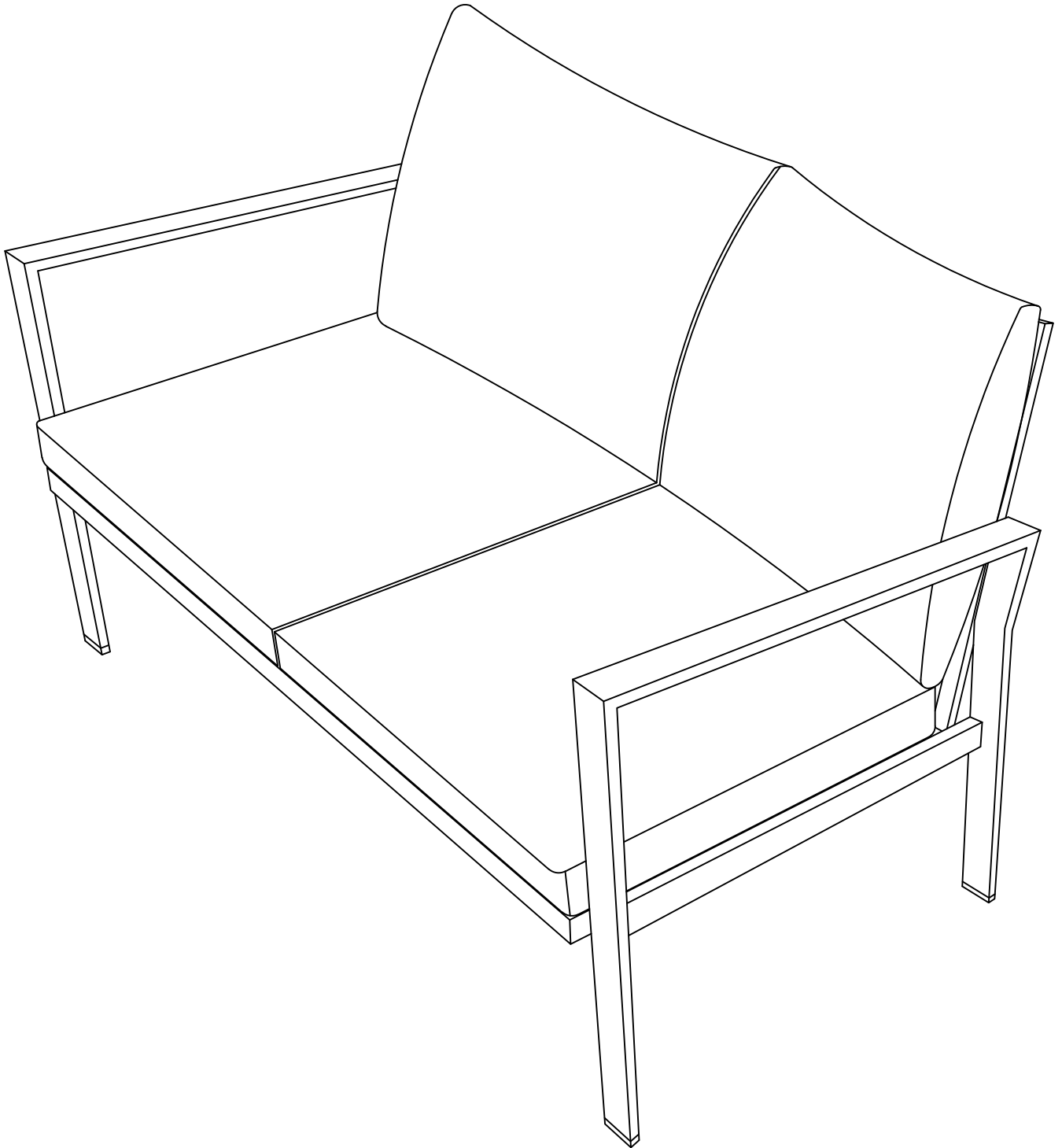

Please read this manual carefully before any operation and keep it properly for future use.

If any problems on our product, please feel free to contact us.

Exploded View

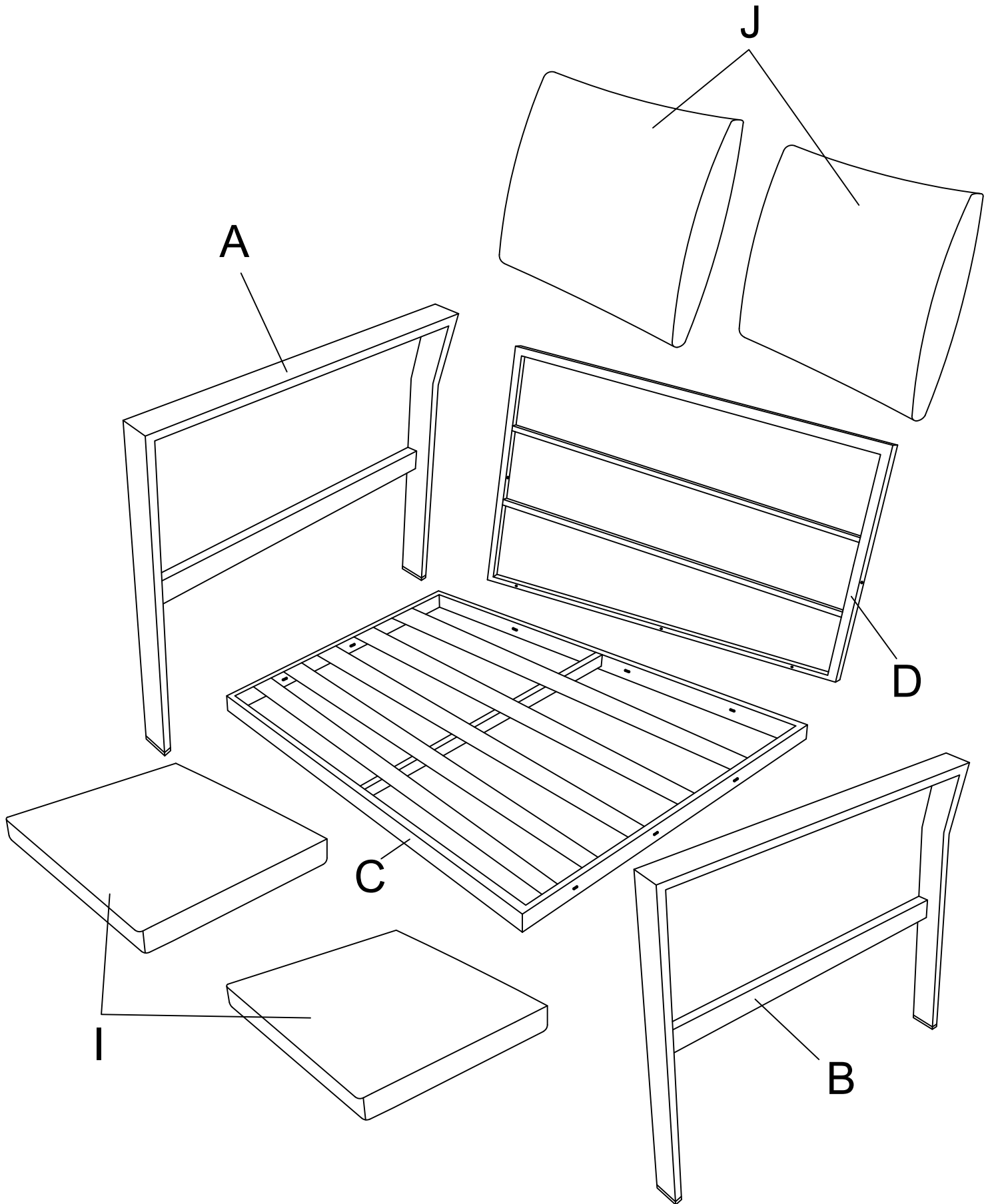

Components List

A

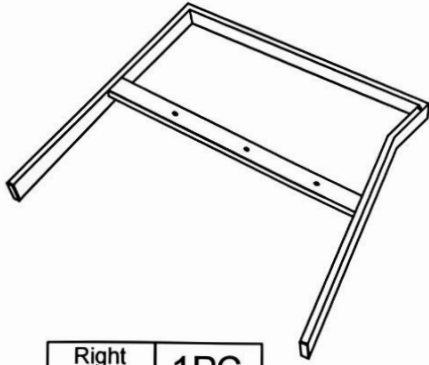

Right Armrest 1PC

B

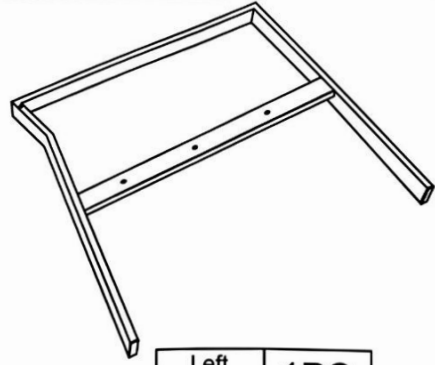

Left Armrest 1PC

C

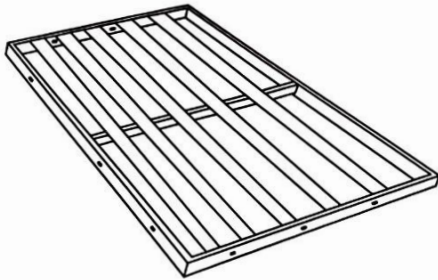

Seat 1PC

D

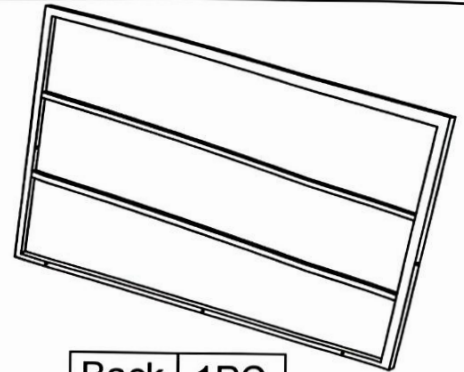

Back 1PC

E



Bolt M6X25 9+1 PCS

F

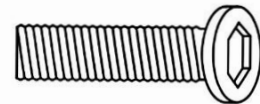

Bolt M6X40 2+1 PCS

G



Washer M6 11+2 PCS

H



Allen wrench M6 1PC

I

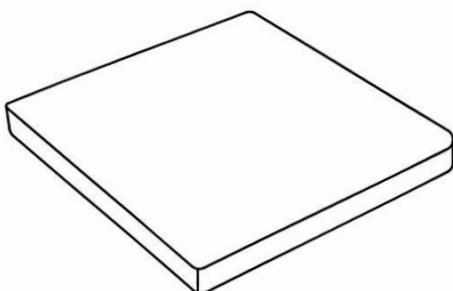

Seat Cushion 2PCS

J

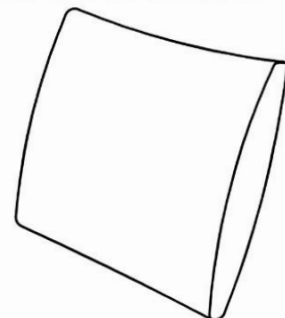

Back Cushion 2PCS

ASSEMBLY INSTRUCTION

Step 1 Attach right armrest(A) to the seat board(C) using washers(G), bolts(E) and Allen wrench(H). *Hand-tighten all screws to about 80% first. After all screws are in place, tighten them fully in sequence*

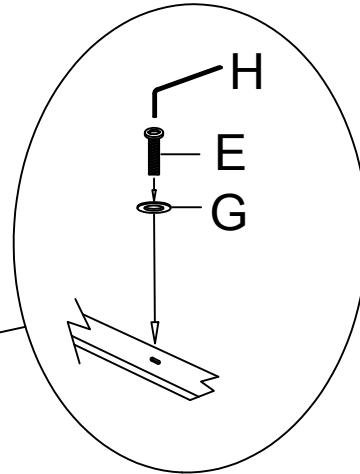
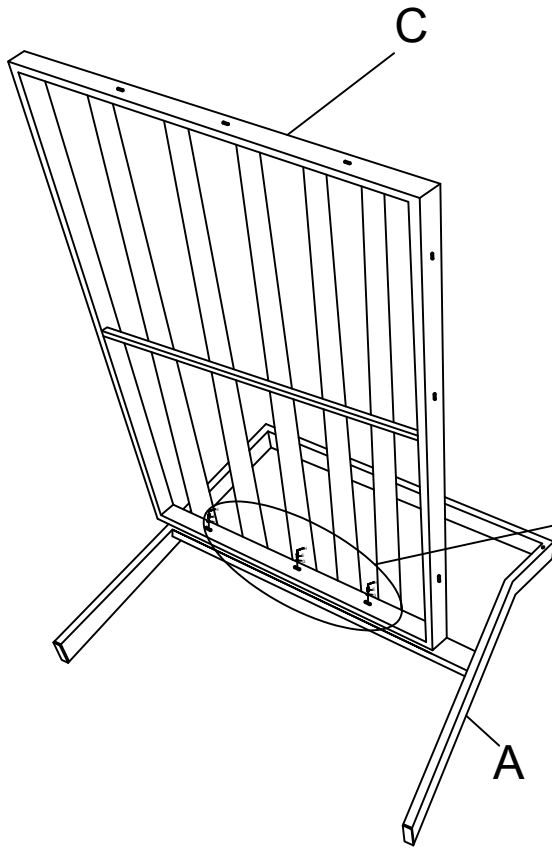

	AX1
	CX1
	EX3
	GX3
	HX1

Step 2 Attach back frame(D) to the seat frame using washers(G), bolts(E&F), and Allen wrench(H). *Hand-tighten all screws to about 80% first. After all screws are in place, tighten them fully in sequence*

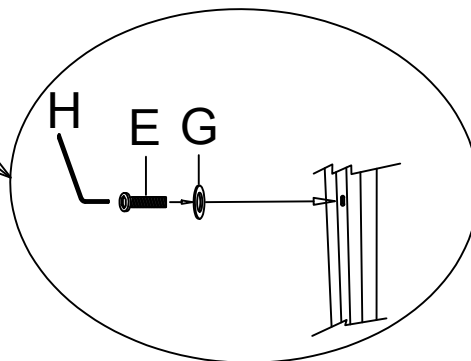
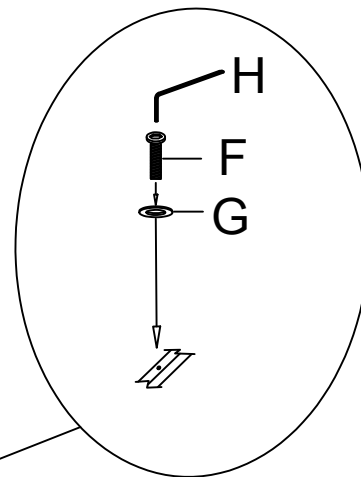
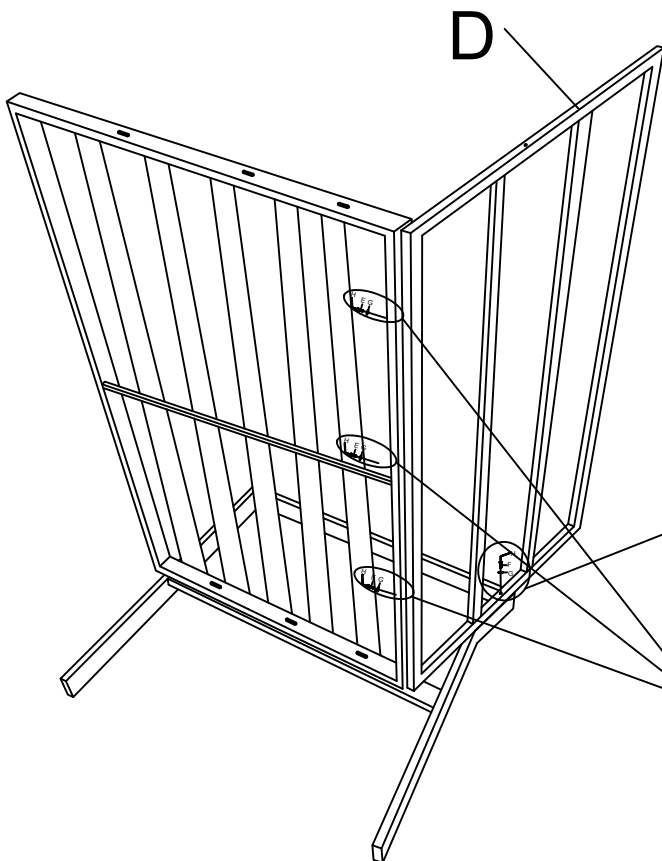

	DX1
	EX3
	FX1
	GX4
	HX1

ASSEMBLY INSTRUCTION

Step 3 Attach right armrest(A) to the seat board(C) using washers(G), bolts(E) and Allen wrench(H). *Hand-tighten all screws to about 80% first. After all screws are in place, tighten them fully in sequence*

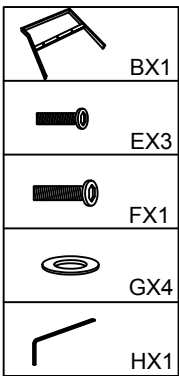
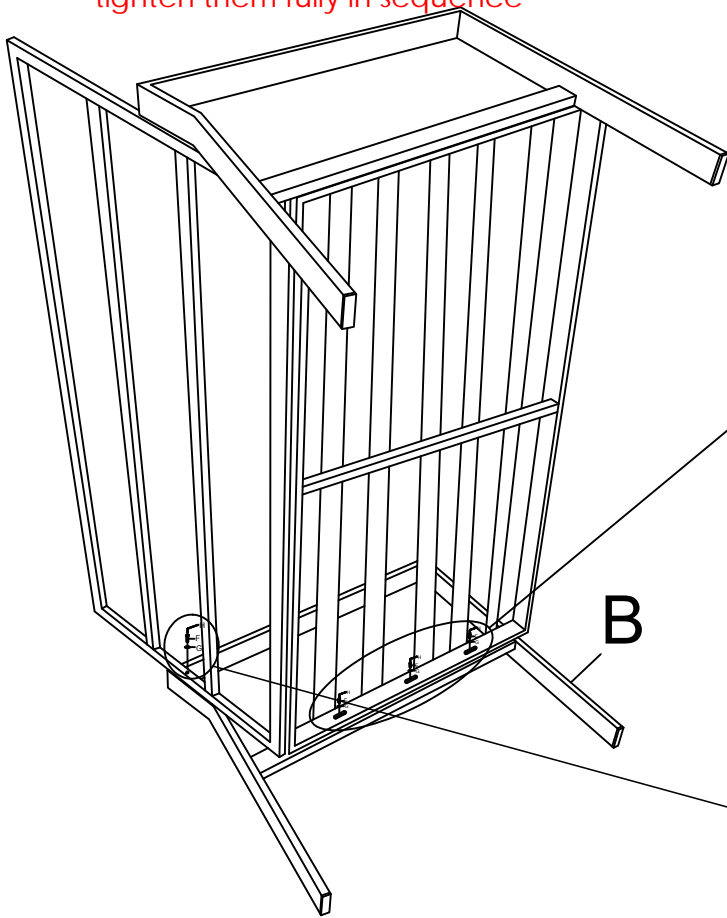

Step 4 Tighten all bolts 100%, and flip the seat over. Put the seat cushion(I) and back cushion(J) on the seat frame. The assembly is done.

