



Sideboard

ASSEMBLY INSTRUCTIONS

Guidelines

Thank you for selecting an Elle Decor Collection piece!

Our primary objective is to provide fast, friendly customer service to all of our customers. We are here to help if you have any questions, comments, or are in need of warranty replacement parts.

Please call us toll free at: 1-855-372-2315 U.S.
0-800-051-6775 U.K.

U.S. Monday - Friday 6:00am - 5:00pm PST,
U.K. Monday - Friday 2:00pm - 1:00am U.K. Time

Or visit our website:
www.truecustomersupport.com
www.trueinnovations.com

FAILURE TO FOLLOW THESE WARNINGS WHEN IN USE COULD RESULT IN INJURY

- Do not stand on the item or use as a step ladder
- Do not use this item unless all bolts and screws are firmly secured and fastened.
- Check all bolts and screws every 90 days. As necessary tighten if any are loose.
- Lift up then move. Pushing over or dragging this product can result in an injury or cause damage to the floor and piece.

Pre-Assembly Preparation:

Please read through this instruction booklet before beginning assembly of this item.

Two adults are recommended for assembly.

- Clear out the space for assembly and lay out all parts on Parts List, extra room will allow you to easily determine if all the pieces are present.
- Save all packing materials until assembly is complete to avoid accidentally discarding smaller parts or hardware.
- Keep small parts and pieces away from children and pets until fully assembled.
- Please check for any loose screws and tighten them before you use.

WARNING: DO NOT LET CHILDREN PLAY IN OR AROUND THE UNIT DUE TO THE POSSIBLE RISK OF INJURY.

Parts List

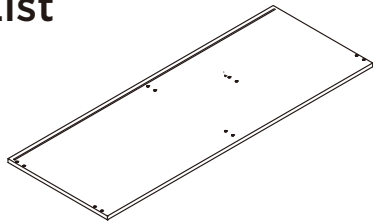

Ⓐ Top Panel X 1

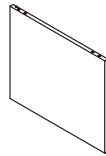

Ⓑ Side panel X 1

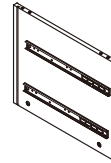

Ⓒ Side panel X 1

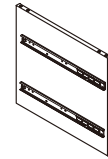

Ⓓ Central Panel X 1

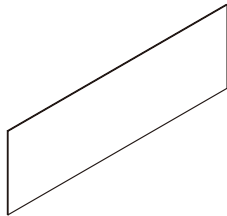

Ⓔ Back panel X 1

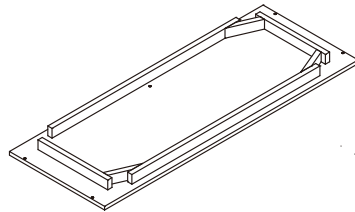

Ⓕ Bottom Panel X 1



Ⓖ Legs X 2



Ⓖ Legs X 2

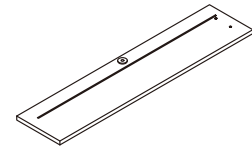

Ⓖ Drawer Front Panels X 1

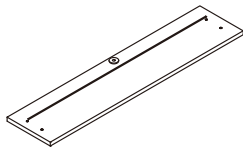

Ⓖ Drawer Front Panels X 1

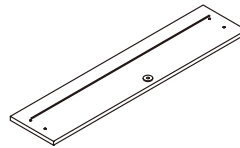

Ⓖ Drawer Front Panels X 1

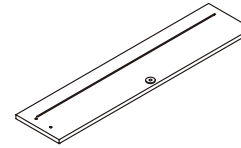

Ⓖ Drawer Front Panels X 1

Parts List

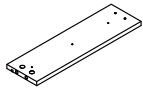

(M) Drawer Side Panels X4

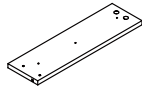

(N) Drawer Side Panels X4

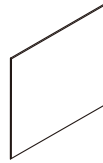

(O) Drawer Bottom Panels X 4

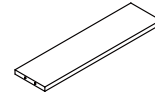

(P) Drawer back panels X 4



(Q) Cambolts X 6
(35 MM)



(R) Camlocks X 6
(14 MM)



(S) Wood Dowels X 12
(M8 x 30MM)



(T) Screws X 6
(M7 x 50MM)

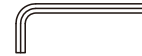

(U) Allen Key (M4) X1



(V) Bolts X 8
(M6X40MM)



(W) Flat Washers (M6) X 8



(X) Pads X 4
(30X30)



(Y) Cambolts X 16
(25 MM)



(Z) Camlocks X 1
(10 MM)



(AA) Bolts X 16
(M5X40MM)



(AB) Allen Key (M3) X1

- Step 1--**
1. Remove all parts from the carton and place them on a protected surface or carpet.
 2. Insert Cambolts (Q) into Panel (A) & insert Wooden Dowels (S) into Top Panel (A).

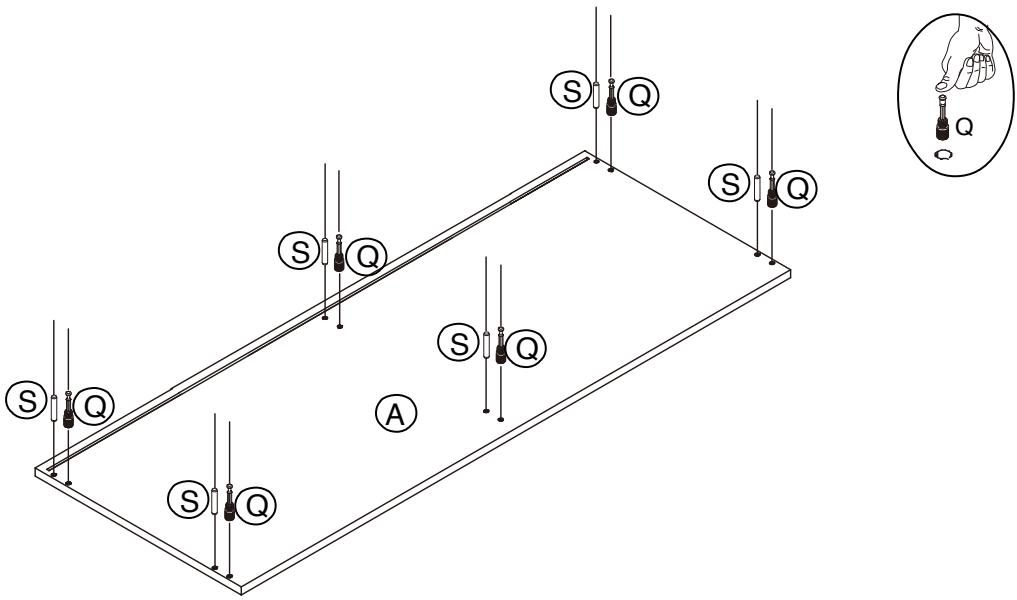

Step 2--

1. Insert the Camlocks (R) into Side Panels (B), (C) & Central Panel (D) ensuring the open indicator is pointing towards the panel edge before tightening with a screwdriver.
2. Attach Side Panels (B), (C) & Central Panel (D) to Top Panel (A).
3. Then use the screwdriver (not provided) turn clockwise to fasten the Camlocks (R) as shown. Ensuring the open indicator is pointing towards the panel edge before tightening with a screwdriver.

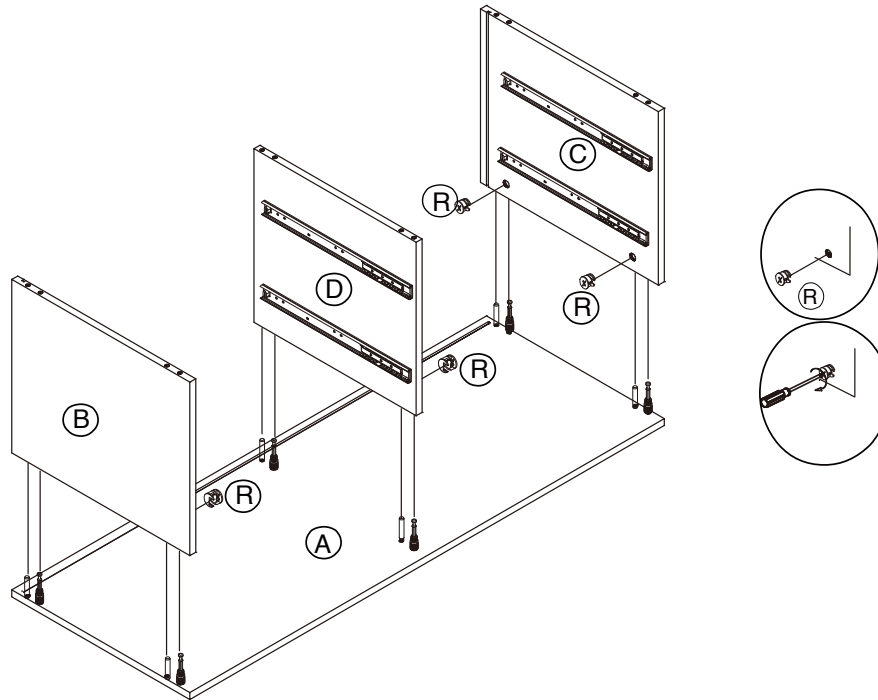

Step 3-- Slide Back Panel (E) into the grooves of the unit as shown.

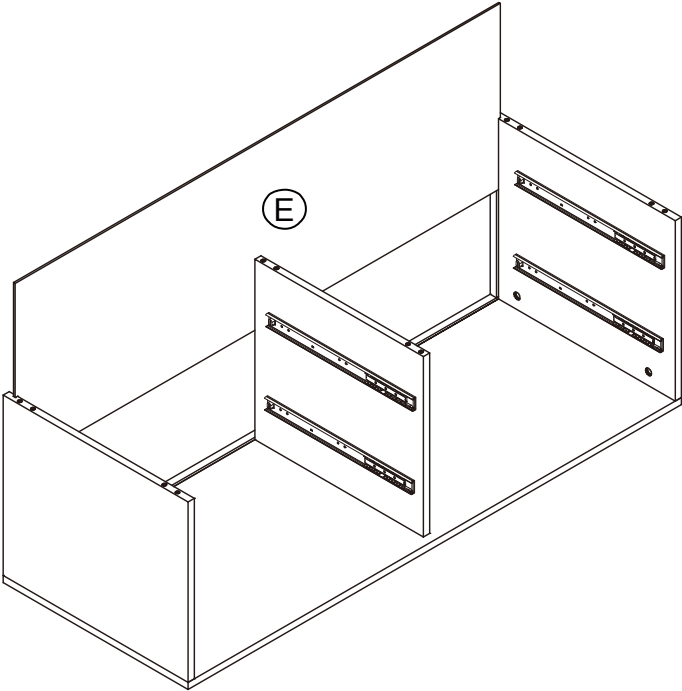

Step 4-- Insert Wood Dowel (S) into Side Panel (B), (C) & Central Panel (D)

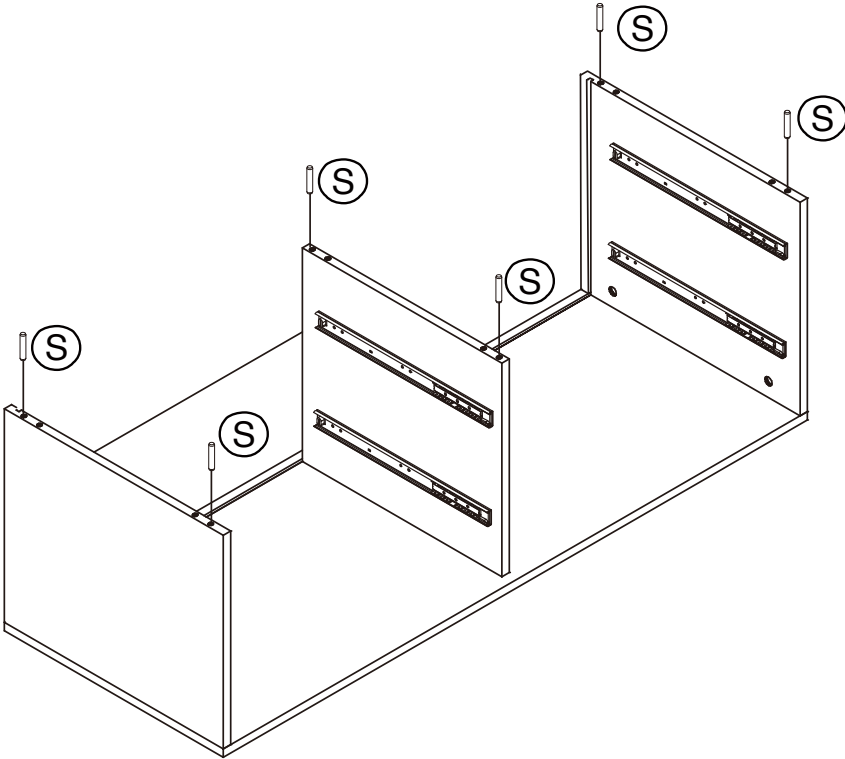

Step 5-- Attach Bottom Panel(F) to assembly unit with Screws (T) and tighten with Allen key (U).

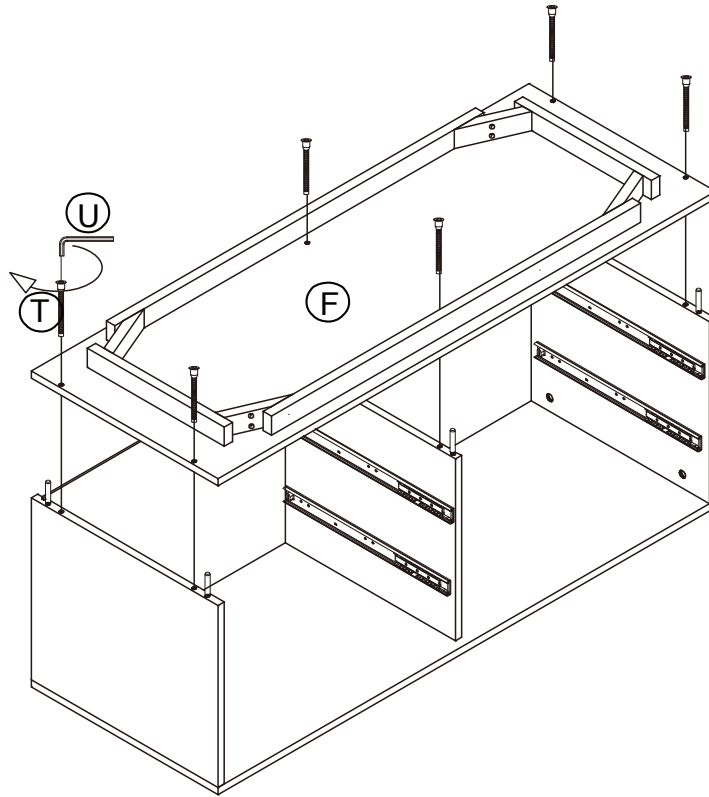

Step 6--

1. Align Legs (G) top to label (G) on the base of Bottom panel (F) & Legs (H) top to label (H) on the base of Bottom panel (F) as shown. Connected by Bolts (V) with Flat Washers (W) and securely with Allen Key (U).

2. Remove the cover on Pads (X) & stick Pad (X) on the bottom of Legs (H) and (G).

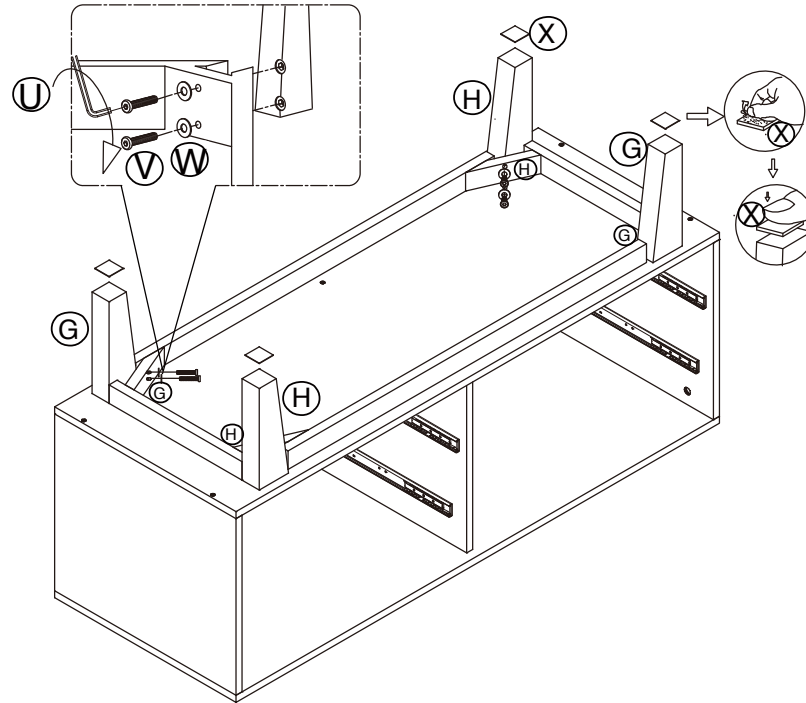

Step 7-- Insert Cambolts (Y) into Drawer Front panels(I), (J), (L) & (K) by a screwdriver (not provided) until tight.

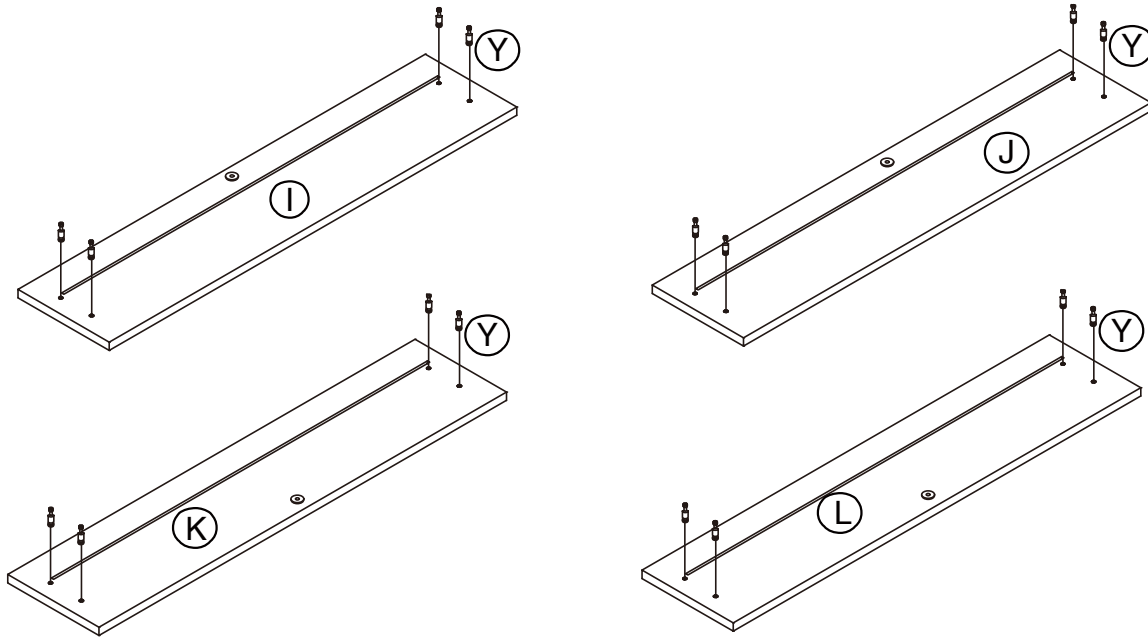

Step 8-- Insert the Camlocks (Z) into Drawer Side Panels (M) & (N). Ensuring the open indicator is pointing towards the panel edge before tightening with a screwdriver .

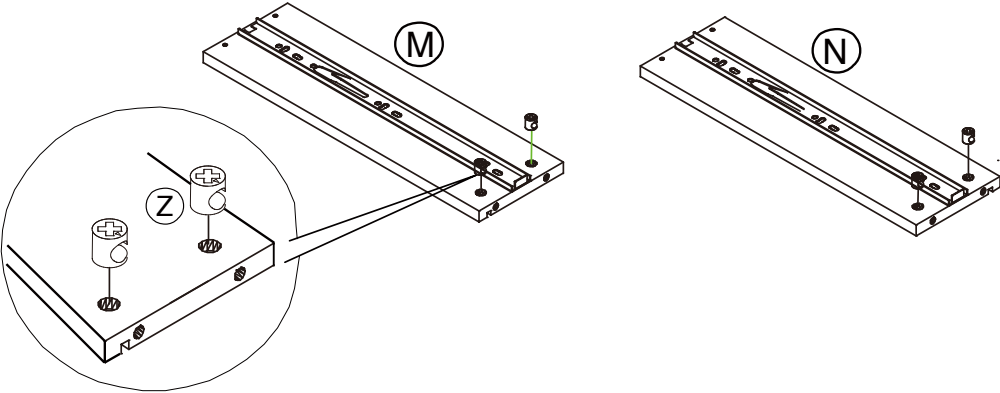

X4

Step 9-- Attached Side Panel (M) & (N) to drawer front panels (I), (J), (L) & (K) as shown then use the screwdriver (not provided) turn clockwise to fasten the Camlocks (Z).

Ensuring the open indicator is pointing towards the panel edge before tightening with a screwdriver

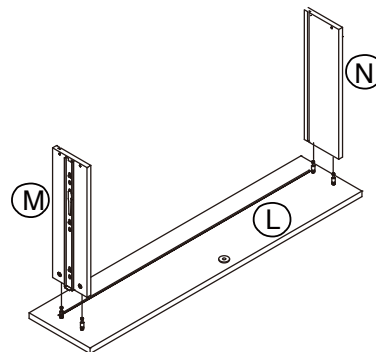
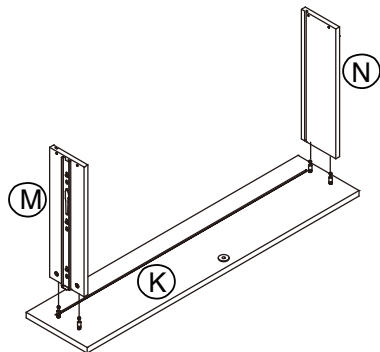
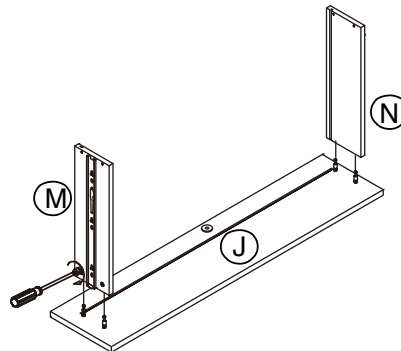
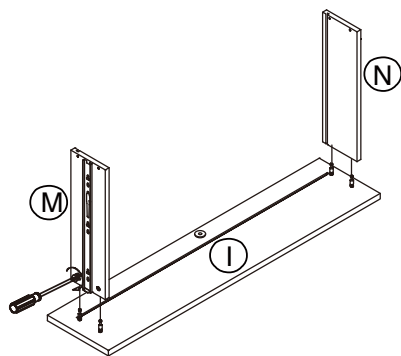

Step 10-- Slide Drawer Bottom Panels (O) into the grooves of the drawer frame (I), (J), (K) and (L).

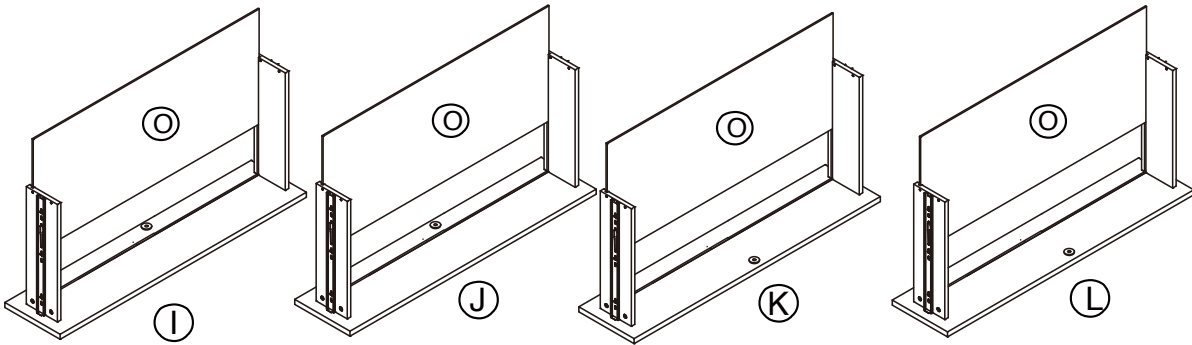

Step 11-- Attach Drawer Back Panel (P) to assembly unit (I), (J), (K) & (L) by Screws (AA) and securely with Allen Key (AB).

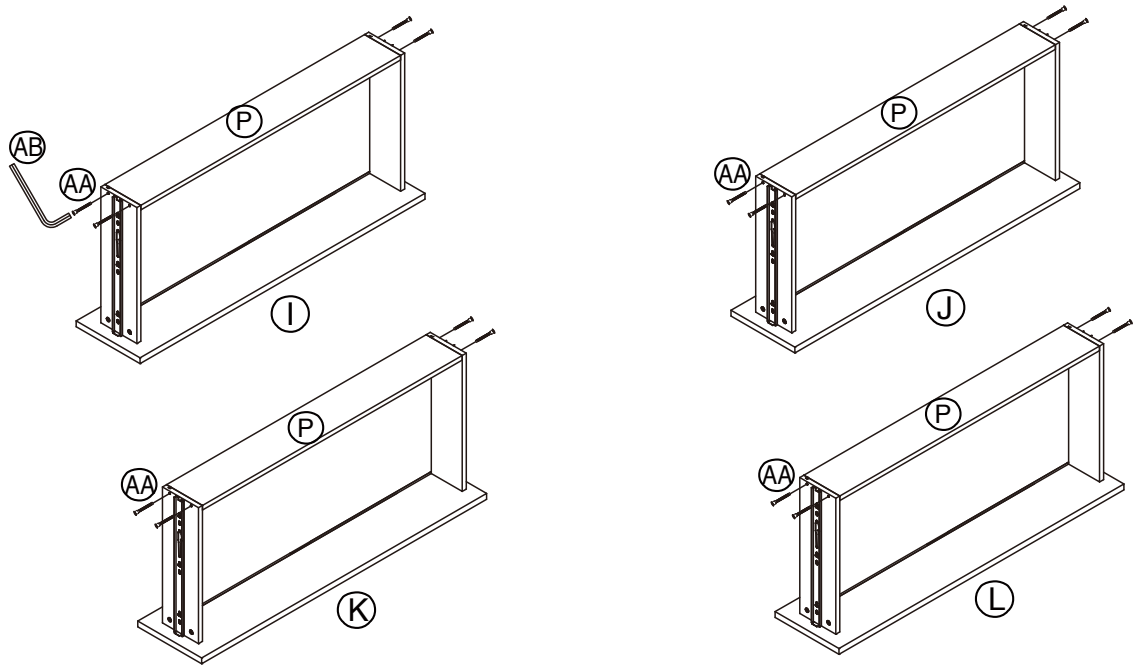

Step 12-- Click the plastic bracket inside the runner and install the drawer as shown.
Note: If you want to disassemble the unit, please follow the steps as the brief to push the drawer out.

Left side

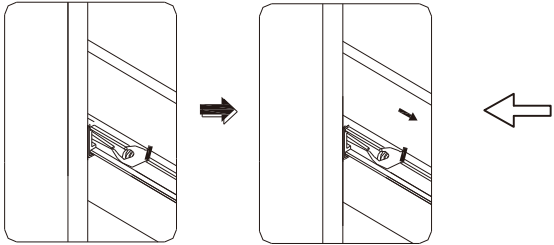

Right side

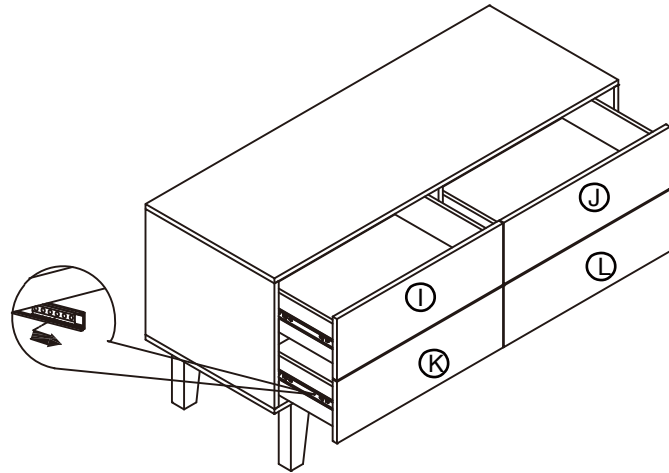
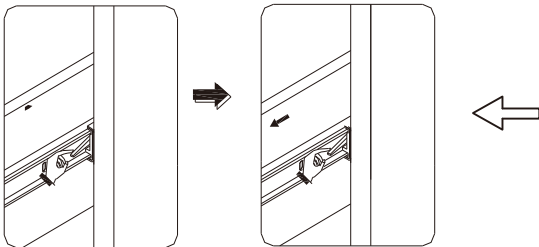

Step 13-- **Warning:** Always ensure intended wall area to be drilled is free from hidden electrical wires, water and gas pipes.

1. Secure the other end of the strap to the wall with an appropriate screw and wall plug for your wall type (not provided).

NB: Wall fixings are not included. Please source suitable fixing for your wall type. If in doubt, please consult a local hardware store.

2. To hide the strap behind the unit, drill the hole lower than the top of unit.

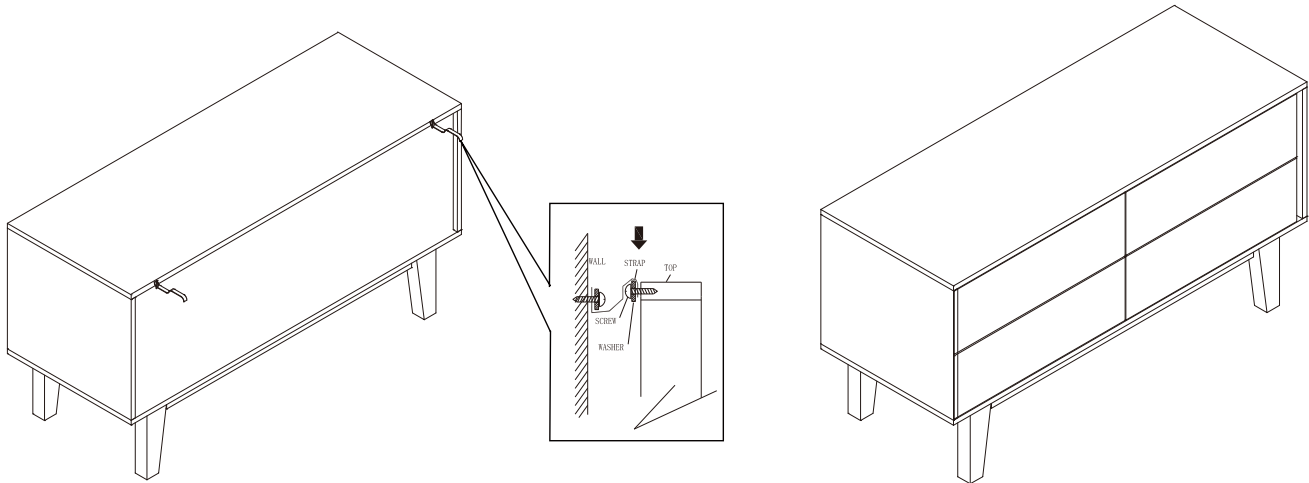

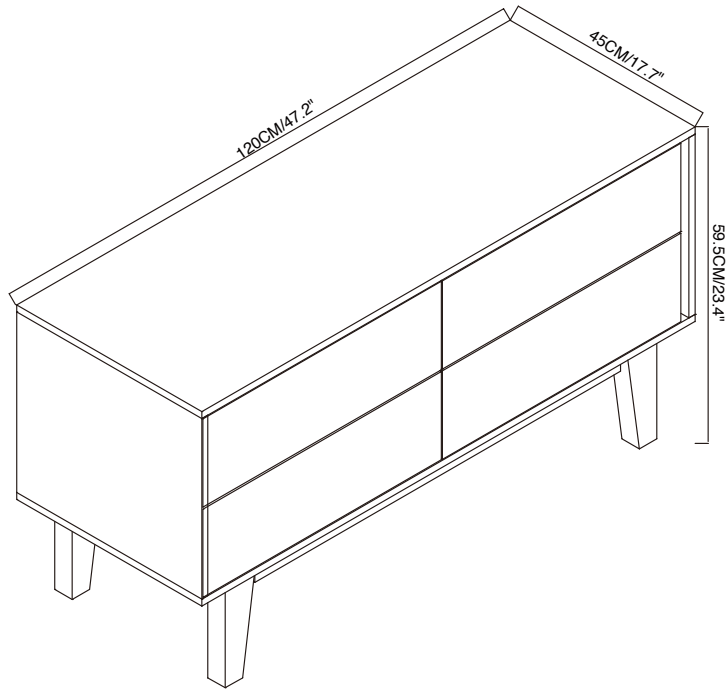

Product Dimension

Limited Warranty

The product you have purchased is warranted against defects in material and workmanship while owned by the “Original Purchaser”. The term “Original Purchaser” is defined as that party or entity which purchases these products from an authorized dealer or retailer as shown by the original sales receipt. This warranty does not apply to “as is” or previously owned products.

The manufacturer warrants its products to be free from defects in materials and workmanship (normal wear and tear, fading and stretching excepted), for one year from the date of purchase, except as provided below under the limited warranty.

This warranty gives you specific rights, and you may also have other rights, which vary from state to state (or country to country). All warranties are limited to the original purchaser for normal use by a maximum of two users. Total weight capacity per chair is 250 pounds for a single user.

The exceptions or exclusions to this warranty are:

- Upholstery material and foam cushion material is warranted against defects in material and workmanship for a period of one year, beginning on the date of purchase as shown on the original sales receipt.
- Any warranty claim that is submitted after the limited warranty period, or without proper proof of purchase will not include the cost of parts, labor, or delivery on the warranted parts within a reasonable amount of time. We reserve the right to require damaged parts to be returned to us upon request. Natural markings such as scars, brands, grain variations, wrinkles, color variations, etc. will be considered normal characteristics and not construed as defects.
- For claims or questions concerning this warranty, please contact the Customer Service Department on the web at www.truecustomersupport.com. Be prepared to provide your name, address, daytime phone number, the model and purchase order number of the product, date of purchase, and the store where it was purchased. The manufacturer requires that the original sales receipt be submitted with all requests to confirm that you are the original purchaser according to our written warranty.