

**COMPLETE COMPUTER WORKSTATION
DESK WITH STORAGE**

ASSEMBLY INSTRUCTIONS

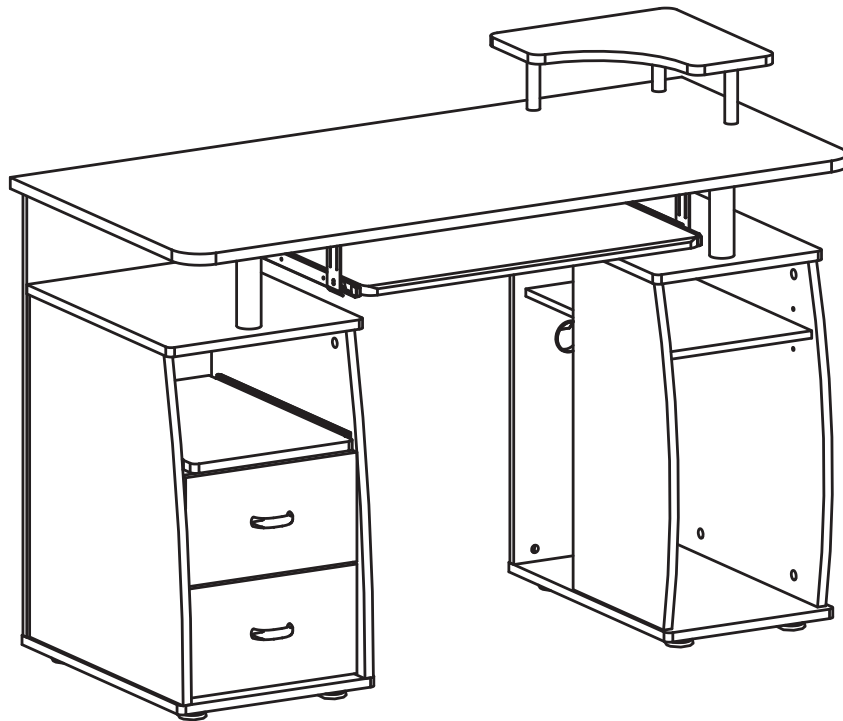

Do a quick inventory of all the parts and hardware listed below.









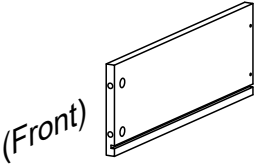
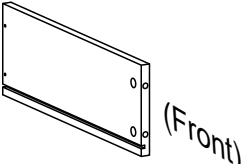
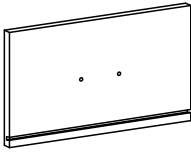
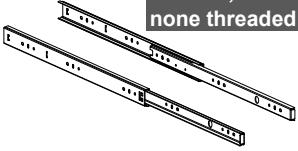

For Support, assembly questions & Replacement Parts within the 48 Contiguous United States.

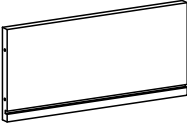

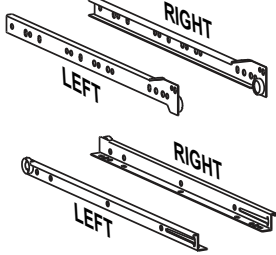
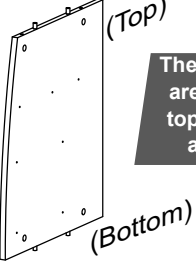
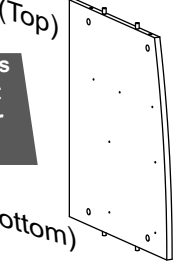
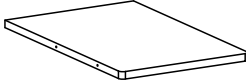
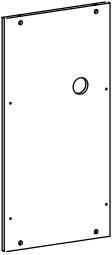
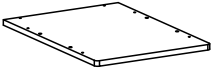



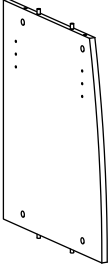
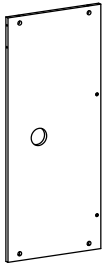
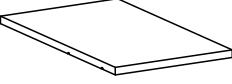

Replacement Parts for International Customers orders:
 Products will replace the part free of charge, while **the customer is responsible for shipping costs plus any International local taxes or duties.**

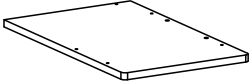
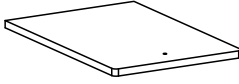
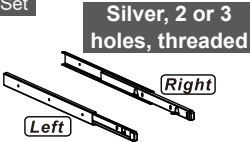
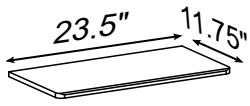
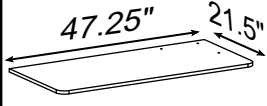

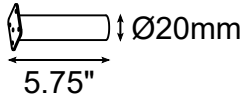

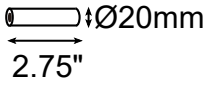
MAIN PARTS LIST





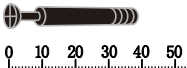
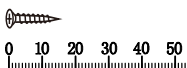

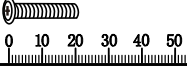
<p>1 Drawer left panel x2</p> 	<p>2 Drawer right panel x2</p> 	<p>3 Drawer front panel x2</p> 	<p>4 Sliders for sliding shelf x2</p>  <p style="font-size: small; background-color: #333; color: white; padding: 2px;">Black, lots of holes, but none threaded</p>
<p>5 Drawer bottom panel x2</p> 	<p>6 Drawer back panel x2</p> 	<p>7 Handle x2</p> 	<p>8 Sliders for drawer: Each set is 4 pcs. x2 Sets</p> 
<p>9 Left panel for drawers' cabinet x1</p> 	<p>10 Right panel for drawers' cabinet x1</p> 	<p>11 Sliding shelf x1</p> 	<p>12 Back panel for drawers' cabinet x1</p> 
<p style="text-align: center; background-color: #333; color: white; padding: 2px;">These 2 panels are narrow at top and wider at bottom</p>		<p>13 Bottom panel for drawers' cabinet x1</p> 	<p>14 Top panel for drawers' cabinet x1</p> 
<p>15 Glide studs x8</p> 	<p>16 Left panel for CPU's cabinet x1</p> 	<p>18 Right panel for CPU's cabinet x1</p> 	<p>19 Back panel for CPU's cabinet x1</p> 
<p>17 Adjustable shelf x1</p> 			

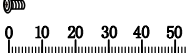
MAIN PARTS LIST (Cont.)

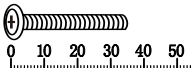
20 Bottom panel for CPU's cabinet x1 	21 Top panel for CPU's cabinet x1 	22 Sliders for keyboard x1 Set Silver, 2 or 3 holes, threaded 	23 Keyboard panel x1 	24 Tabletop x1 
25 Base bracket keyboard sliders x4 	26 Thick support tube for tabletop x2 	27 Central back panel x1 	28 Thin support tube for top shelf x3 	29 Top corner shelf x1 

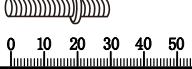
HARDWARE LIST

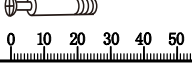
PART	QTY	SIZE / DESCRIPTION	ITEM
A	16	M6x40 (Large Cam bolt)	
B	26	M3x15	
C	8	M4x35	
D	4	M4x20	
E	12	M4x14	
F	4	M6x12	
G	4	M4x4	

PART	QTY	SIZE / DESCRIPTION	ITEM
H	5	M6x35	
I	2	Ø40x1.5 (Plastic washer)	
J	3	M6x30 (Double ended)	
K	6	M5x40 (Euro screw)	
L	20	M6x25 (Small cam bolt)	
M	4	Ø5x17 (Metal pin)	
N	2	Grommet	

INCLUDED TOOLS

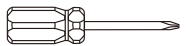
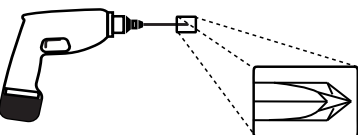
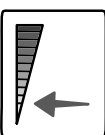
1	Phillips Screwdriver	 ✕
<p>If you decide to use your own power driver:</p> <ul style="list-style-type: none"> Make sure to have the appropriate Phillips bits. Start using at a low torque or speed to avoid stripping the screws. 		
 		

MAIN PARTS LAYOUT (For reference)

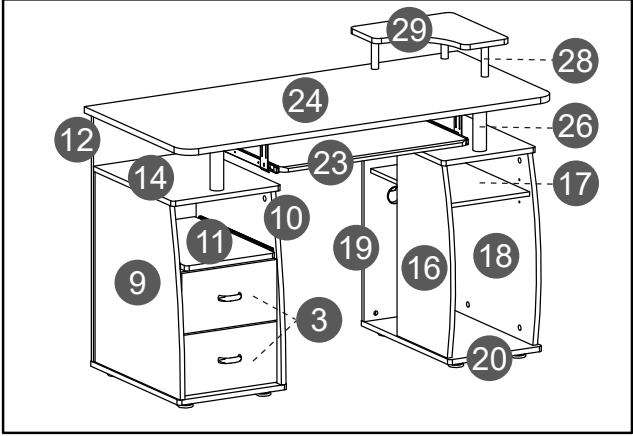

BEFORE YOU START THE ASSEMBLY, PLEASE READ THE FOLLOWING TIPS AND WARNINGS.

- The product assembles **ONLY** as shown in the front page, with the drawers on the **LEFT** side. The drawers cannot install on the **RIGHT** side.

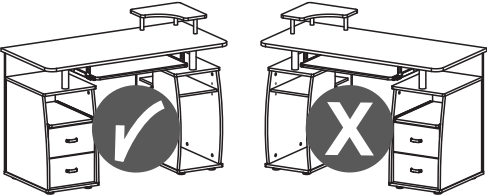

- Do not discard this manual or any of the packaging material until the unit is completely assembled.
- Please read the assembly instructions thoroughly and follow step by step.



- The assembly might require of 2 persons for certain steps. Before you start the installation, make sure there is someone else nearby to help you.



- Make sure you understand which hardware will be used on each step. Using the wrong size of screw, bolt or pin might strip the threads or cause damage to the part in which it is being used.

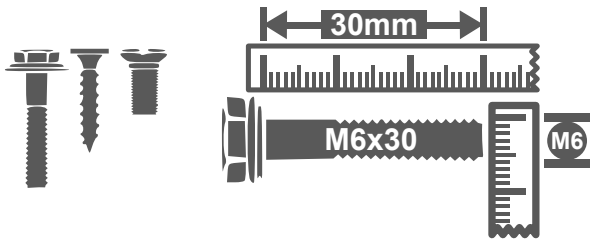

- To avoid misalignments, always leave the screws loosely and do not tighten them until all the pieces are positioned correctly.

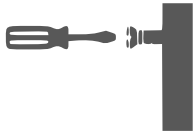

- Do not overtighten or force the screws as they might break, strip, damage the threads of the holes, or get stuck inside the parts.

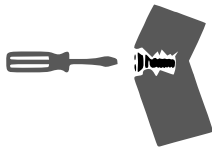

- If the hole seems too small for the screw, make sure you are using the correct size of screw and/or that you are installing it in the correct hole.



- Sometimes on the wood panels the laminate or material might be covering the hole partially or entirely, if there is no visible hole or if it looks too small, pass and press the tip of your finger over the area to feel its indentation, and carefully pierce the laminate to uncover the hole underneath.

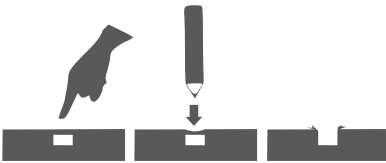

- After the item is assembled, you can use rubbing alcohol to erase or remove the visible part numbers printed or labeled on the pieces.

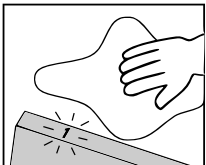

THE ASSEMBLY STEPS START ON NEXT PAGE

CAM BOLT AND CAM LOCK TUTORIAL

THE INSTRUCTIONS BELOW
ARE NOT ACTUAL ASSEMBLY STEPS

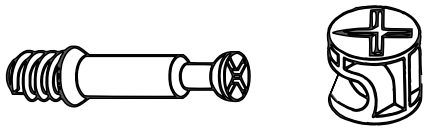

This unit uses cam bolts and locks (also known as mini fixes). If you are not familiar with this kind of hardware, the below is a tutorial that explains how to use them on the steps where they are required.

1. Screw the bolt into the indicated hole on the panel indicated in the assembly step.

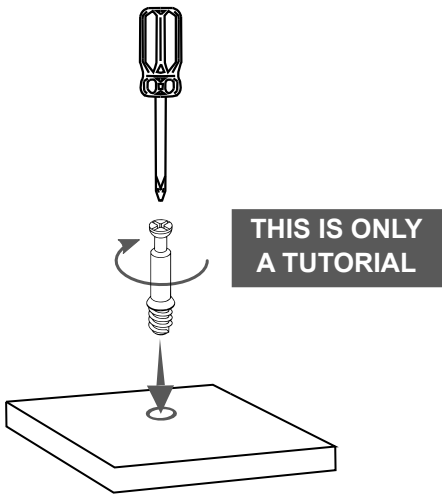

2. Join the other panel (with the big hole) to the panel with the bolt. If it comes with the cam locks already pre-installed, make sure to align them to receive the bolt's head (refer to point 3). There might be a very small gap between the panels which is normal.

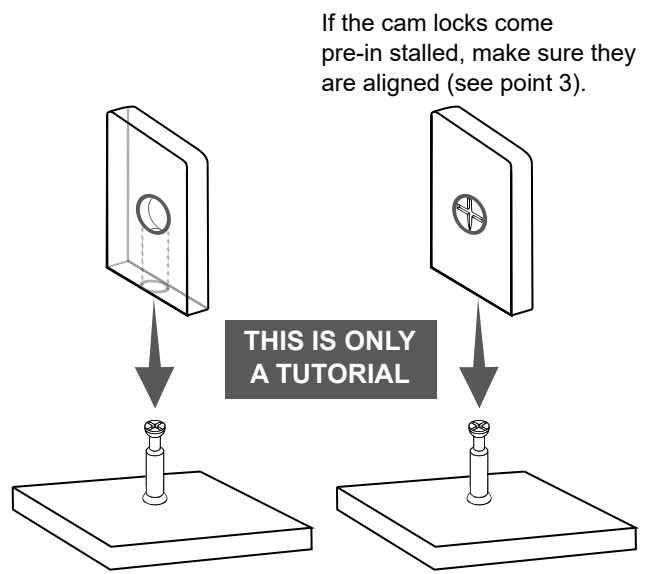

3. Insert the cam lock on the panel with the big hole making sure it goes aligned to receive the bolt's head.

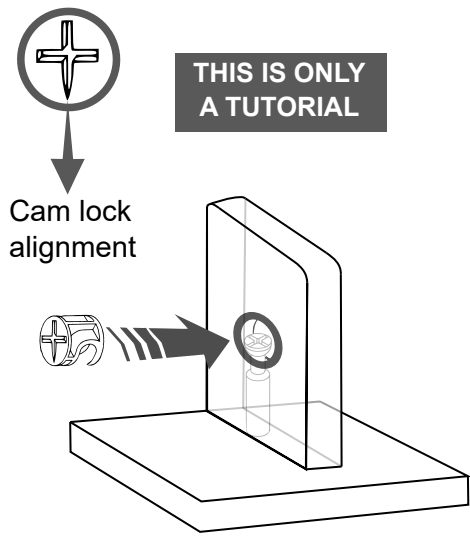

4. Use a Phillips screwdriver to turn the cam lock clockwise. This will lock the panels together and also will close any gaps.

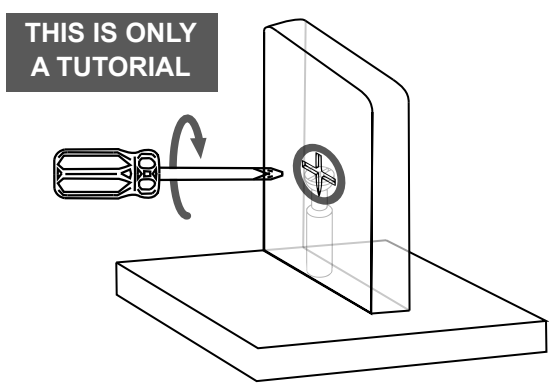

ASSEMBLY STEPS

WE RECOMMEND TO PLACE THE PIECES OVER BLANKETS TO PROTECT THEIR FINISH DURING ASSEMBLY.

STEP 1		
Hardware		
B	M3x15	8 Pcs
Tools (included)		

- Grab all the 3 sets of sliders **8** (total 8 pieces) and separate them into 2 groups according to their shape:
 - The "flat" ones will be used on this step.
 - The "L" shaped won't be used until step **11**, so set them aside.

8 "Flat"

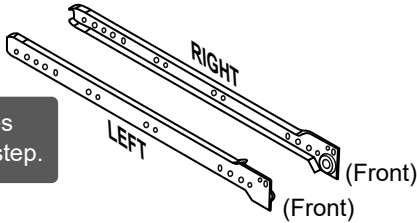

All the "FLAT" pieces will be used in this step.

8 "L" Shaped

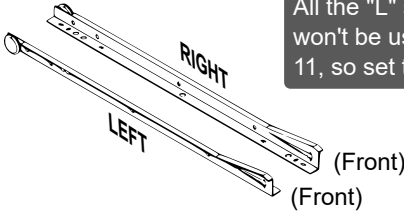

All the "L" shaped pieces won't be used until step 11, so set them aside.

- Assemble the "Flat" sliders **8** to the middle and bottom sets of holes on the side panels **9** (left side) and **10** (right side) with screws **B**, making sure the wheels go facing towards the front and facing down (there will be 2 empty holes above the wheel).
- It is recommended to attach the sliders at the front first, then the back.
- **IMPORTANT:** Make sure to leave the screws **well tightened and as flush as possible** to prevent their heads interfering with the wheels on the drawers.

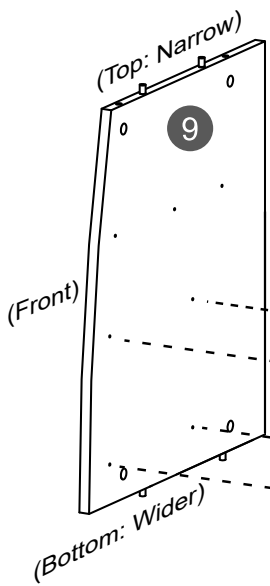
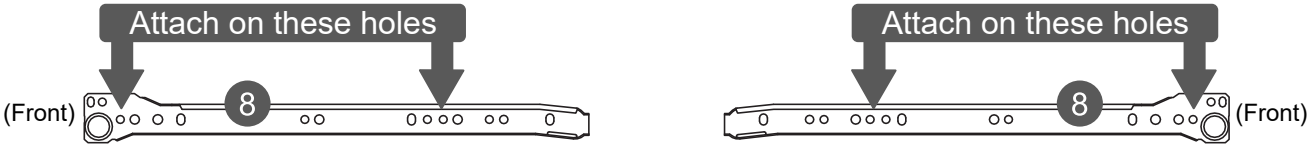

LEFT SIDE

TIGHTEN WELL AND FLUSHED

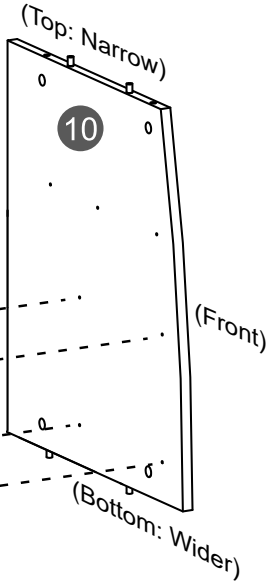
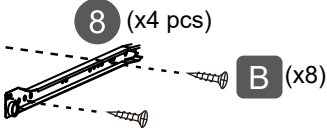
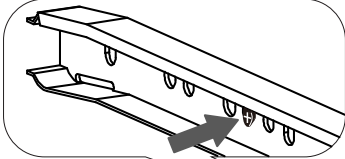

RIGHT SIDE

TIGHTEN WELL AND FLUSHED

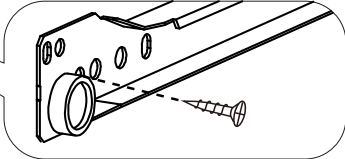

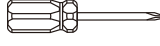
STEP 2		
Hardware		
B	 M3x15	6 Pcs
Tools (included)		
		

VERY IMPORTANT: Make sure you use in this step the correct sliders **4** which are black, longer, and have more holes than sliders 22.

Attach the sliders **4** to the top sets of holes on panels **9** and **10** with screws **B**, starting with the front holes first by opening the sliders slowly until you see the first hole through the big opening; then open the sliders completely and attach on the 2 back holes.

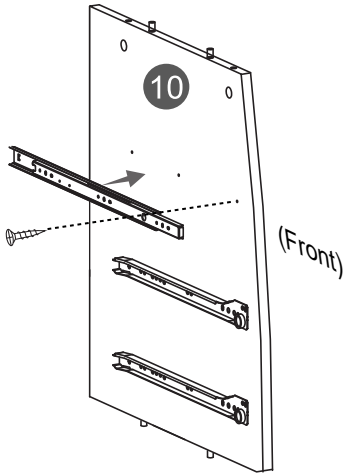
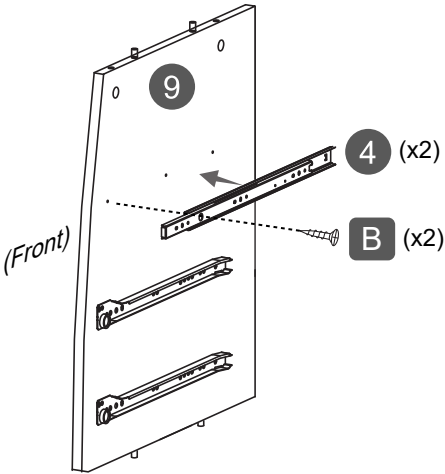
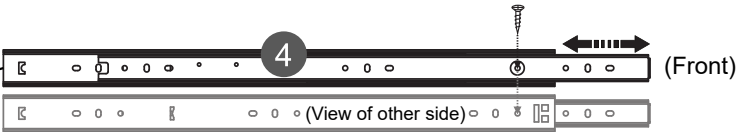

FRONT HOLE FIRST! (Find it through the big opening)

BLACK SLIDERS, no tabs, lots of holes but none are threaded .

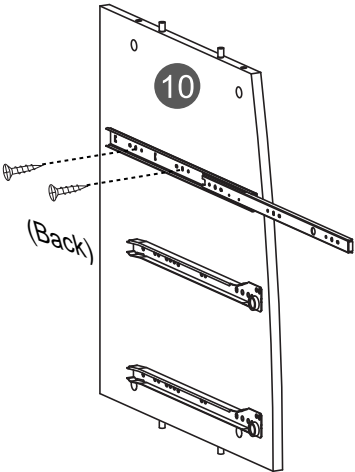
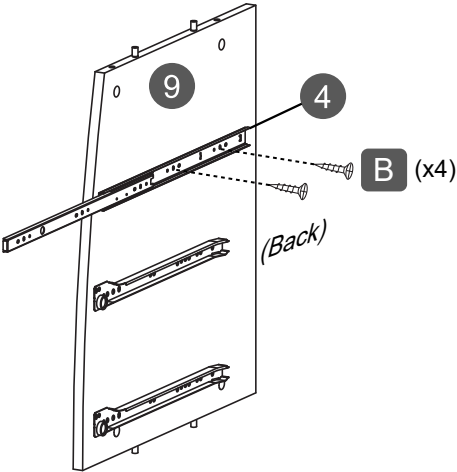
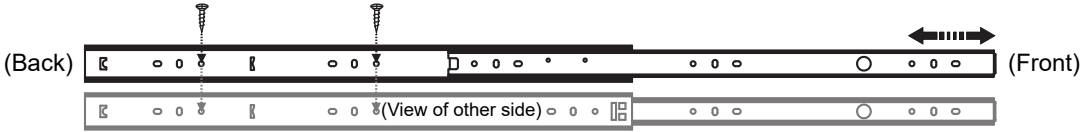

BACK HOLES AFTER. (Open the sliders completely).



STEP 3		
Hardware		
15		8 Pcs
A		8 Pcs
Tools (included)		
		

• Attach the glide studs **15** to the underside face of the bottom panels **13** & **20**. The surface of the panels will have only 4 visible holes.

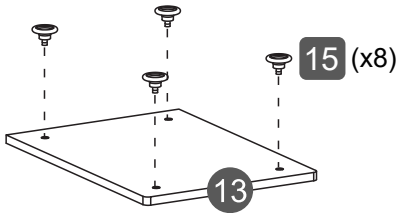

Left side: The cabinet with drawers

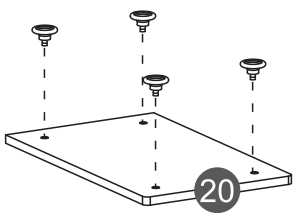

Right side: The cabinet for CPU

• Flip the bottom panels **13** and **20** and identify the front edge. Attach the LONG bolts **A** into the indicated holes on the sides of panels **13** and **20**.

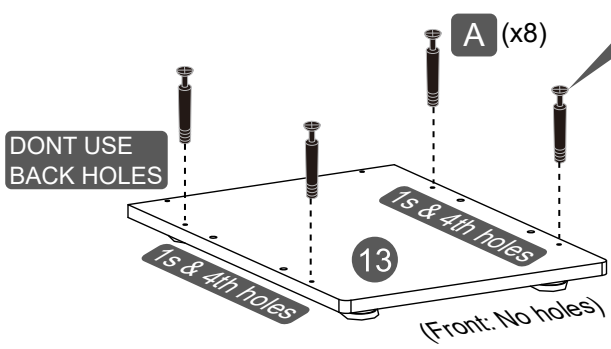

Left side: The cabinet with drawers

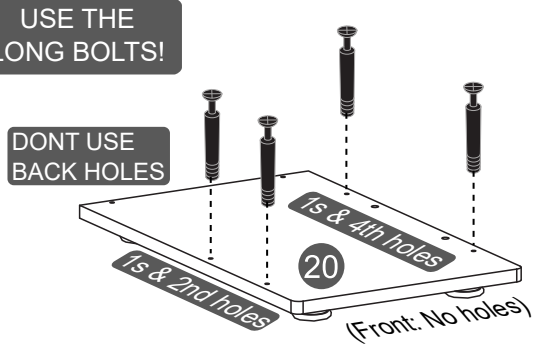

Right side: The cabinet for CPU

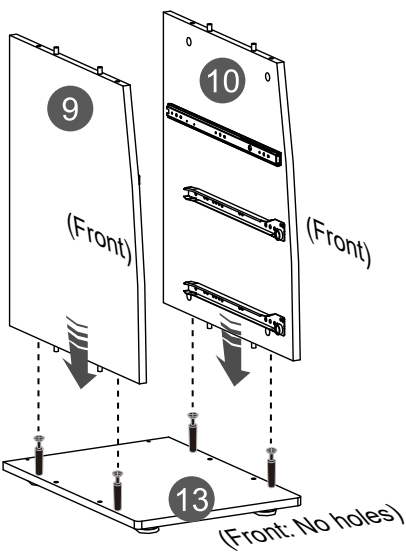

• Assemble the left panel **9** and the right panel **10** to the bottom panel **13** as explained in page 4.
 • Assemble the left panel **16** and the right panel **18** to the bottom panel **20** as explained in page 4.

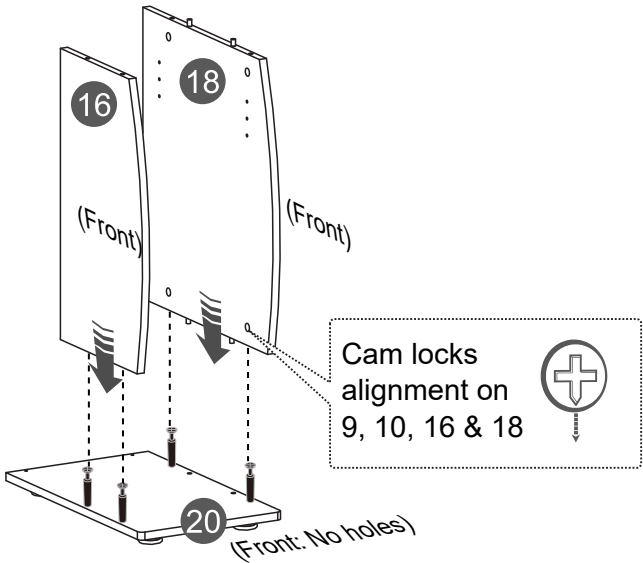

Left side: The cabinet with drawers

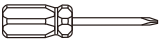

Right side: The cabinet for CPU

STEP 4		
Hardware		
K	 M5x40	6 Pcs
L	 M6x25	4 Pcs
N		2 Pcs
Tools (included)		
		

• Attach the SHORT bolts L into the back holes of the bottom panels 13 and 20.

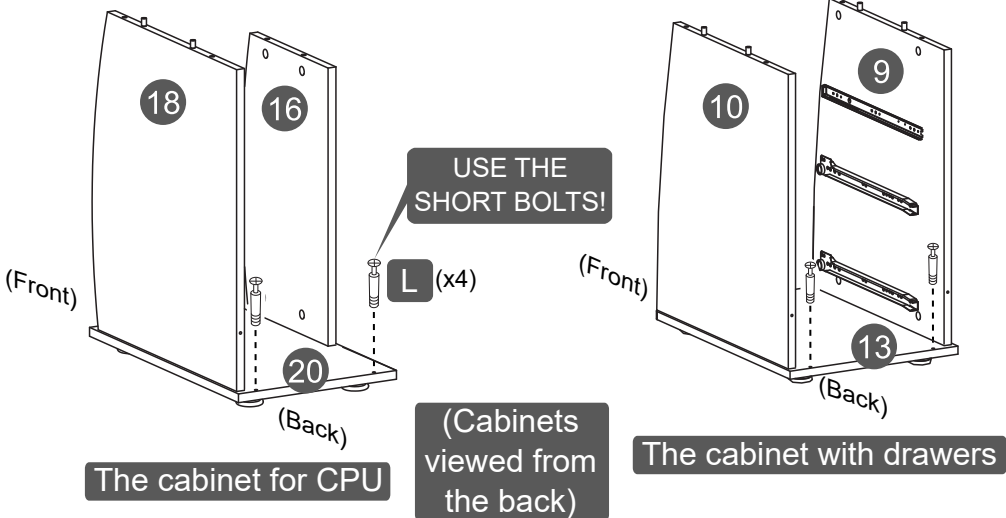

- Assemble the back panel 12 to panel 13 as explained in page 4.
- Assemble the back panel 19 to panel 20 as explained in page 4.

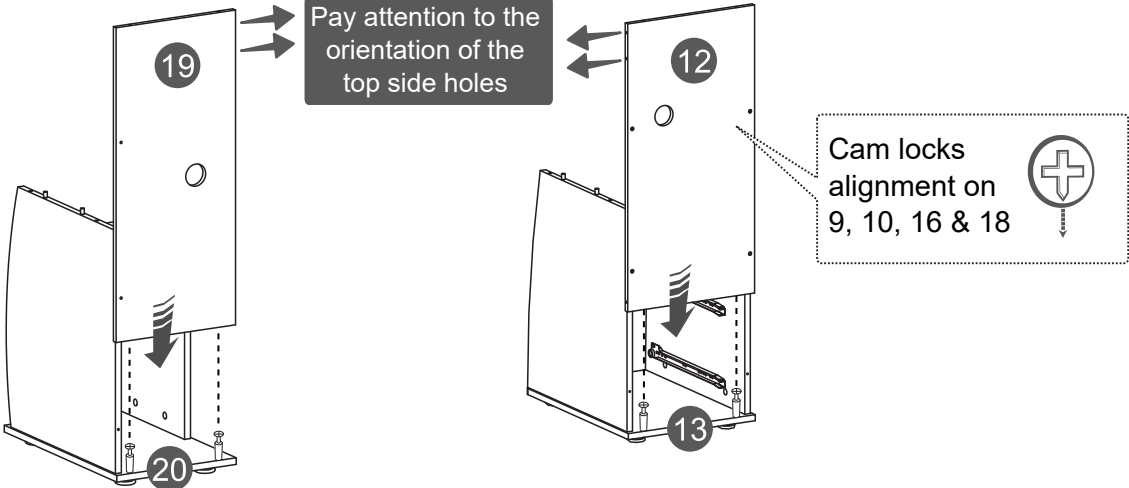

- Secure both back panels 12 and 19 to the respective side panels 9, 10 and 18 with screws K.
- Attach the grommets (cable management) N to both back panels 12 and 19.

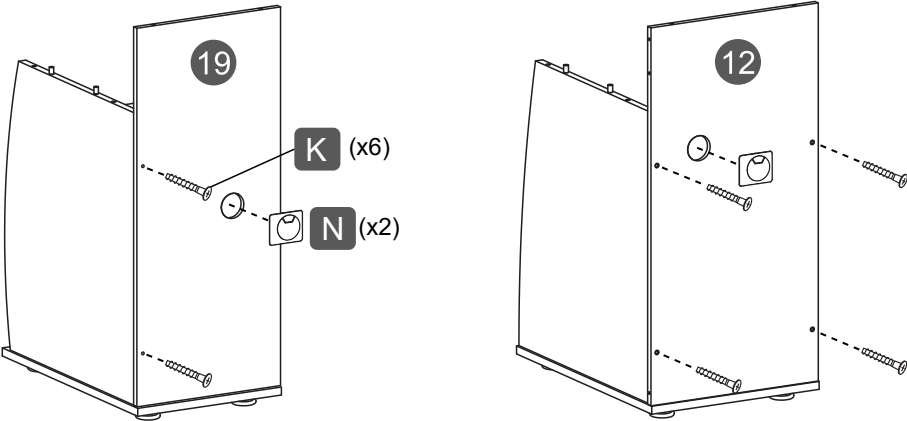

STEP 5

Hardware

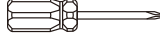
A		8 Pcs
Tools (included)		
		

- Attach the LONG bolts **A** into the indicated holes on the cabinets' top panels **14** and **21**.
- Assemble the cabinets' top panels **14** and **21** to their respective side panels **9-10** and **16-18** as explained in page 4.

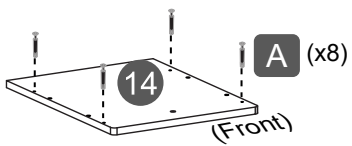

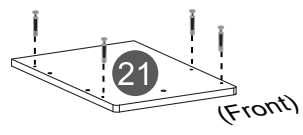

USE THE LONG BOLTS!

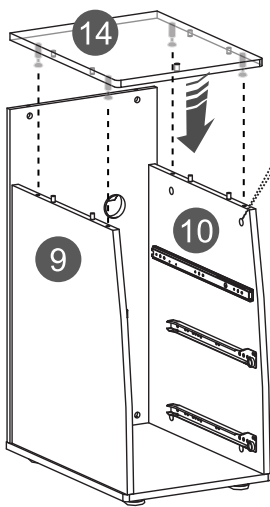

Left side: The cabinet with drawers

Right side: The cabinet for CPU



Cam locks alignment on 9, 10, 16 & 18 

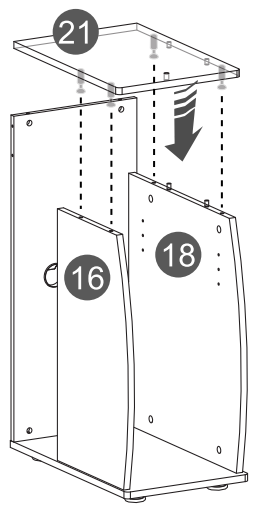

STEP 6

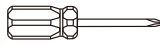

This step requires of  2 persons

Hardware

L		4 Pcs
Tools (included)		
		

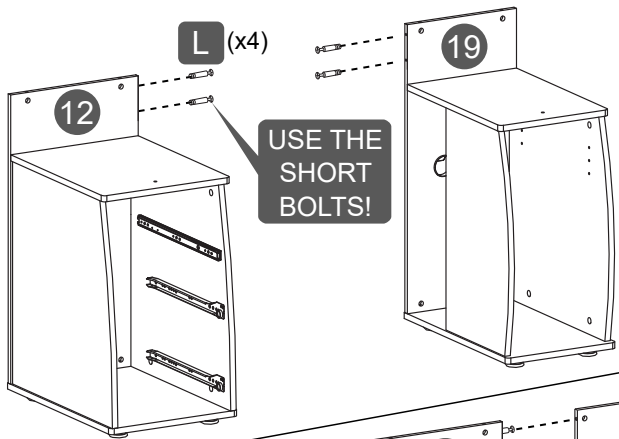
- Attach the SMALL bolts **L** to the back panels **12** and **19** on their interior side.
- With the help of another person, assemble the central back panel **27** to the side panels **12** and **19** as explained in page 4.



Cam locks alignment on 27  

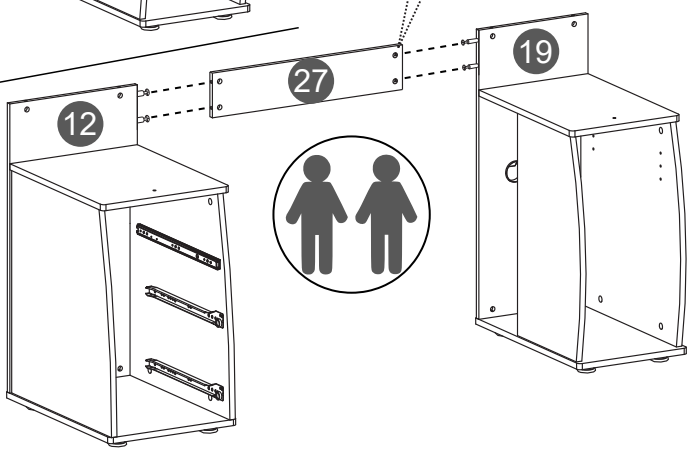

STEP 7

This step requires of 2 persons



Hardware

E		12 Pcs
F		4 Pcs
G		4 Pcs
L		4 Pcs

Tools (included)

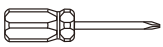

- With the help of another person, place the tabletop **24** upside-down.
- Attach the bolts **L** to the 4 back holes.
- Attach the support tubes **26** to the front with screws **E**.

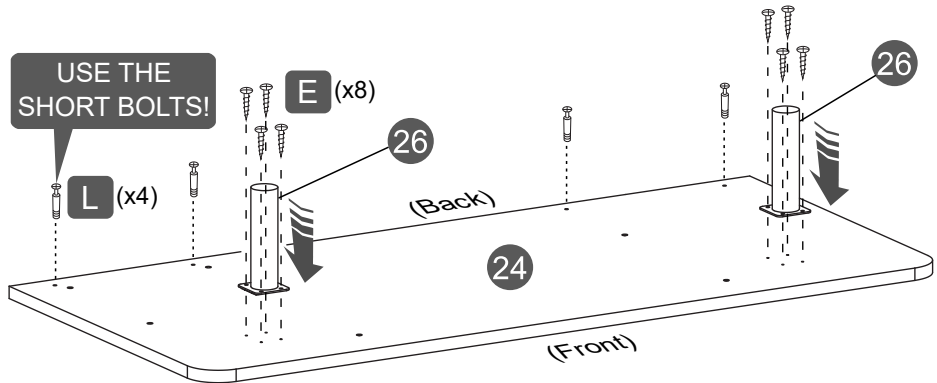

- Flip the keyboard panel **23** upside-down and attach the keyboard sliders **22** with screws **E** in their respective sides.

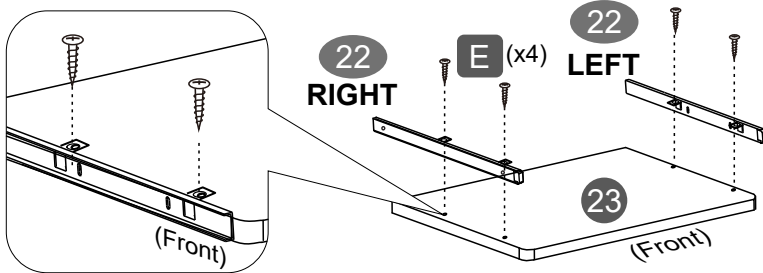

! The sliders #22 have only 2 or 3 threaded holes; if the sliders you are trying to install have lots of holes with no threads, then you are using the wrong sliders #4 and you must go back to STEP 2 and swap these sliders.

- Attach the slider bases (brackets) **25** to the tabletop **24** with screws **F**. Pay attention to the orientation of the bases facing towards the inside of the tabletop.
- With the help of another person, attach the sliders **22** on the keyboard **23** to the bases **25** with screws **G**. Please note that these screws are the exact length to go through the base and into the threaded hole of the sliders; a longer screw cannot be used as it would damage the slider.

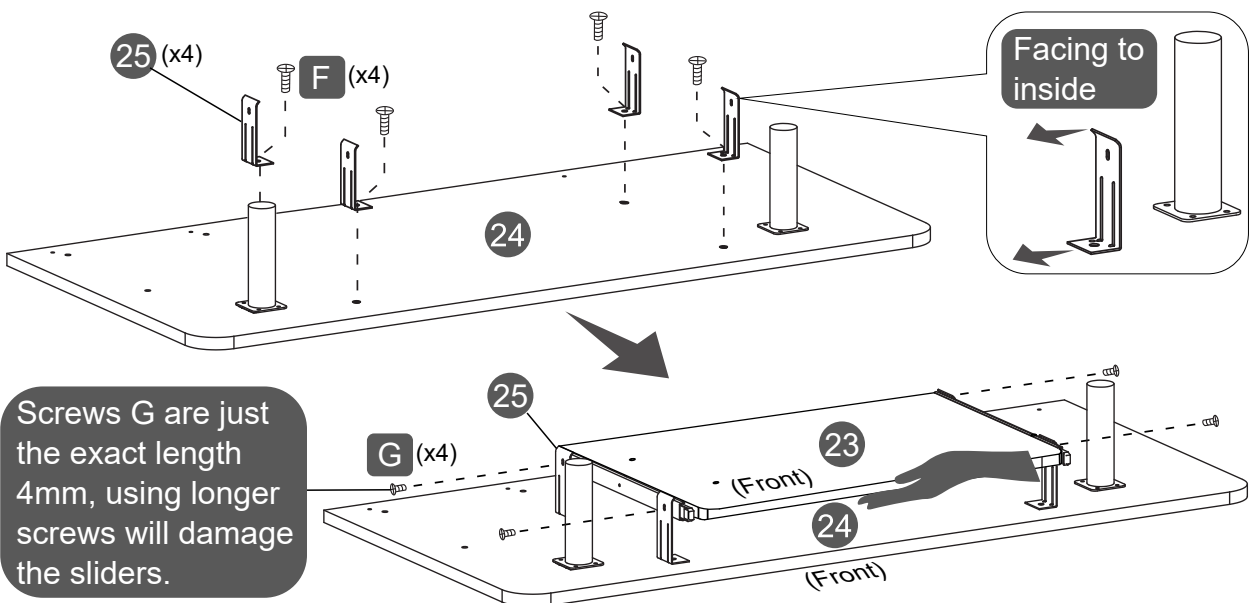



Screws G are just the exact length 4mm, using longer screws will damage the sliders.

STEP 8

This step requires of 2 persons



Hardware

H	 M6x35	2 Pcs
I		2 Pcs

Tools (included)

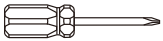

- Place the rubber washers **I** over the front holes of the panels **14** and **21** of each cabinet respectively.

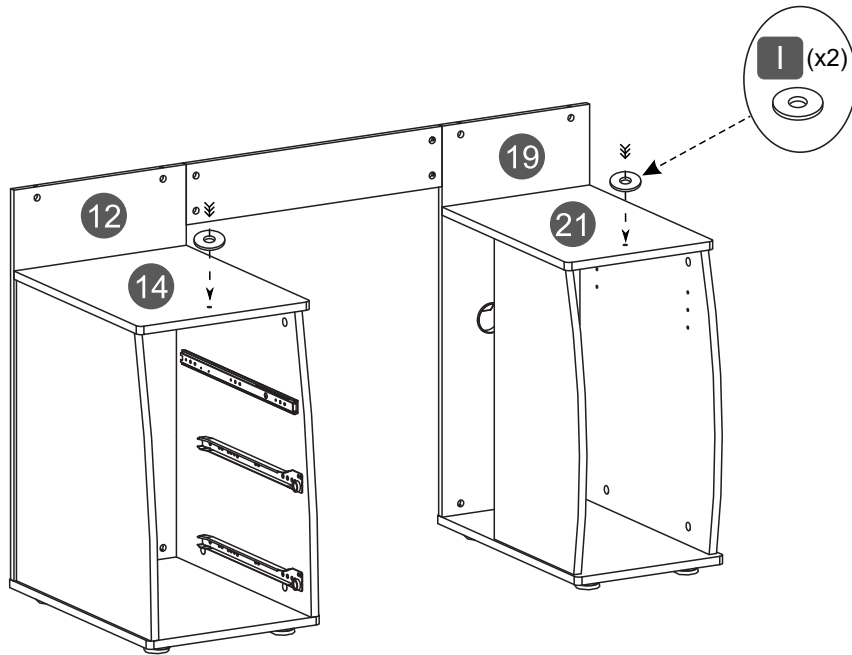

- With the help of another person, carefully place the tabletop **24** over the cabinets making sure the bolts on the back enter into the holes of the back panels **12** and **19**, and the front tubes **26** align with the holes and washers on the cabinets. Secure the cam locks as explained in page **4**.
- Secure the tubes **26** to the top panels **14** and **21** with screws **H**.

Cam locks alignment on 12 and 19

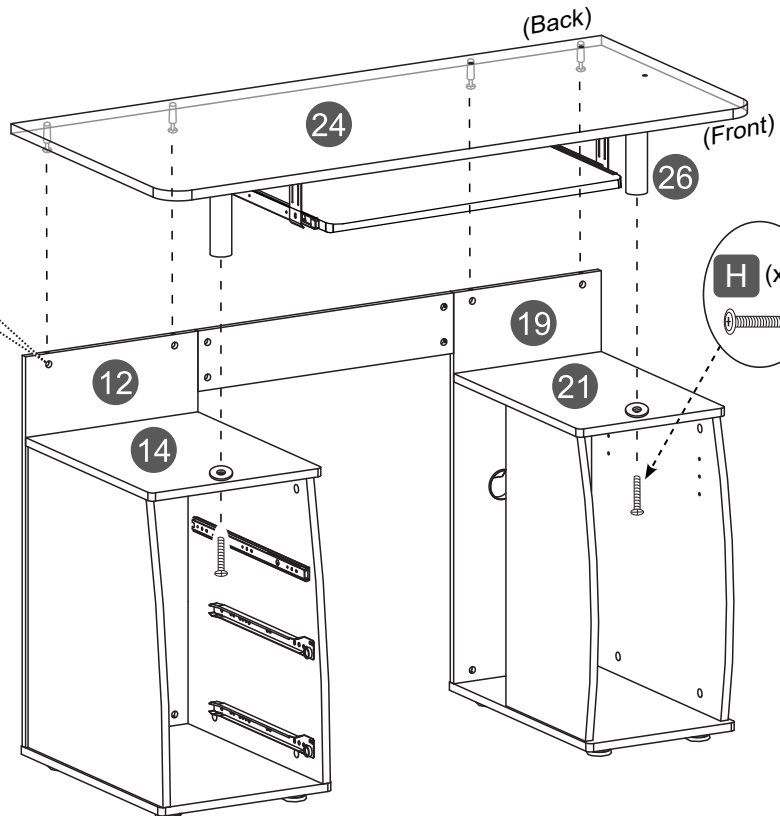

STEP 9

Hardware

H	 M6x35	3 Pcs
----------	--	----------

J	 M6x30 Double ended	3 Pcs
----------	--	----------

Tools (included)

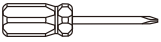

- Install the SHORT END of the screws **J** into panel **29**.

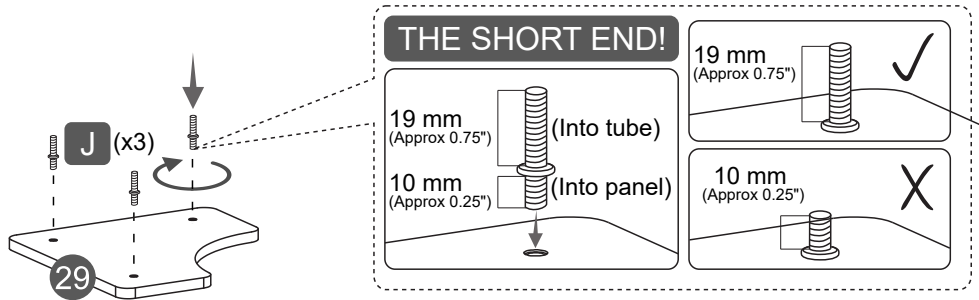

- Attach the tubes **28** to the LONG END of the screws **J**.

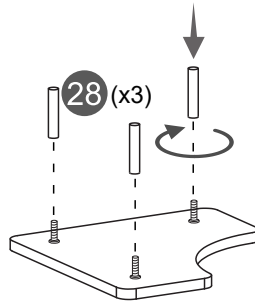

- Attach the tubes **28** from the shelf **29** to the tabletop **24** with screws **H**.

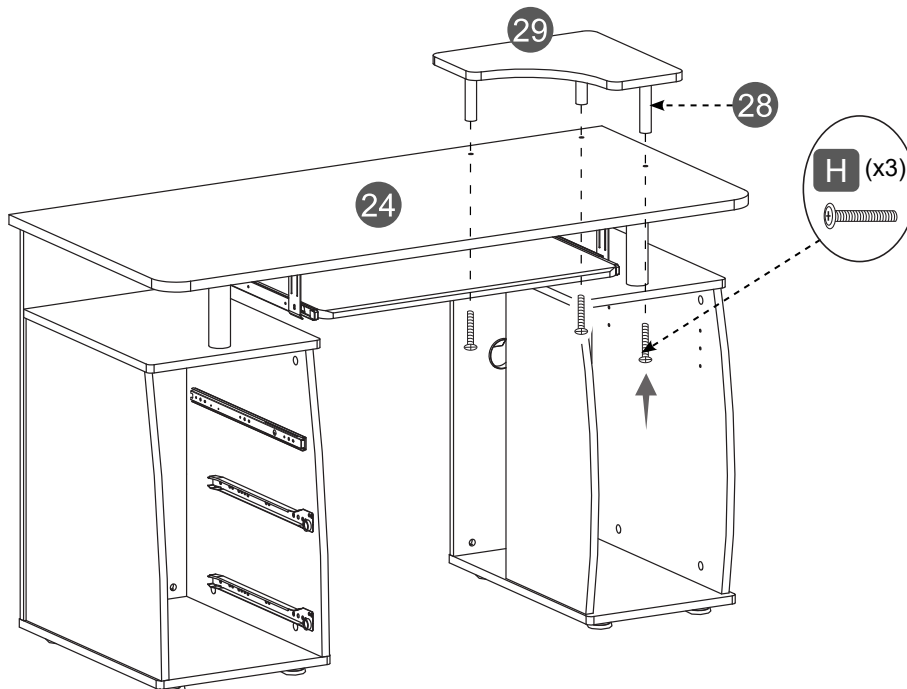

STEP 10

Hardware

C		8 Pcs
D		4 Pcs
L		8 Pcs

Tools (included)

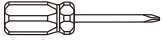

- For each of the drawers, attach the bolts **L** into the indicated holes on panel **3**.
- For each of the drawers, attach the side panels **1** and **2** to the front panel **3** as explained in page 4.

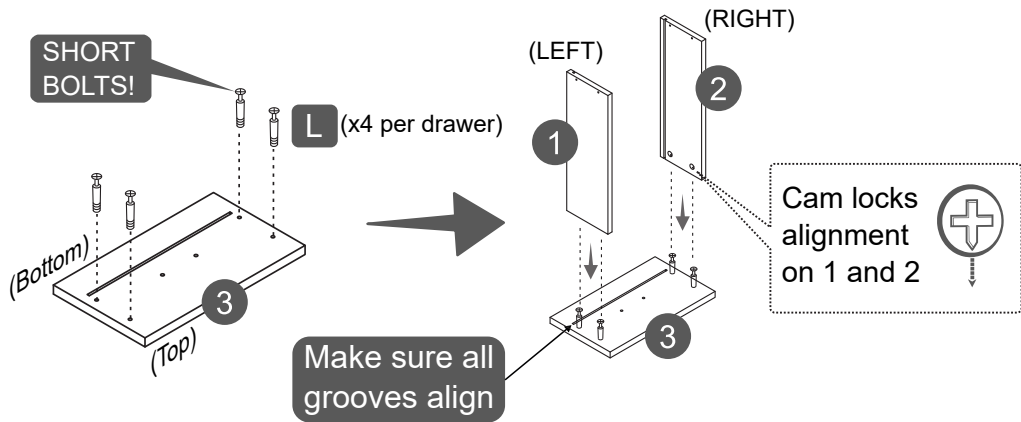

- For each of the drawers, slide the bottom panel **5** through the grooves of the side panels **1** and **2**, and insert into the groove of the front panel **3**.
- For each of the drawers, assemble the back panel **6** to the side panels **1** and **2** with screws **C**.
- For each of the drawers, attach the handle **7** to the front panel **3** with screws **D**.

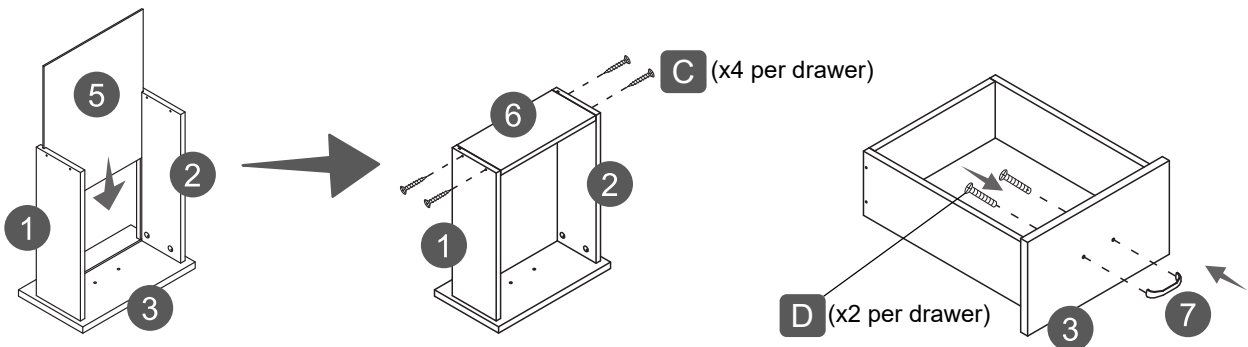

STEP 11

Hardware

B		8 Pcs
----------	--	-------

Tools (included)

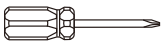

For each of the drawers, flip them upside-down and attach the "L" shaped sliders **8** with screws **B**, and with the wheels towards the back, also making sure that the sliders are flushed with the side panels. If the sliders get installed protruding, they will raise 1" more and won't fit into the unit.

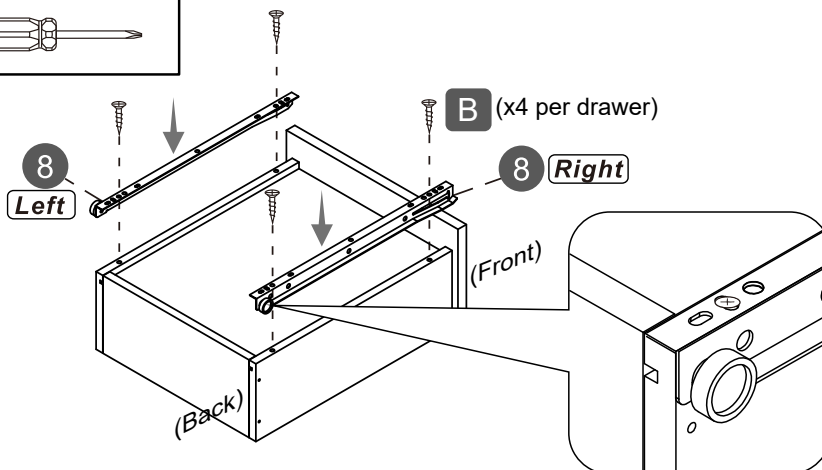

When finished, the sliders will look like this at the back:

(Top)

Sliders — (Bottom)

If you install as below, the drawer raises 1" and won't fit in the unit.

Sliders — RAISES 1" !!!

STEP 12

This step requires of 2 persons



Hardware

B	M3x15	4 Pcs
M	Ø5x17 Pin	4 Pcs

Tools (included)

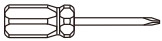

- Insert the drawers into the left cabinet starting with the bottom one. **IMPORTANT:** If the drawers don't close completely, either the sliders inside the cabinet were installed incorrectly, or the screw heads were not tightened flushed. Please review step 1 on page 5 and correct the issue.

The wheels from the drawer must slide in the middle of the sliders, not on top on them.

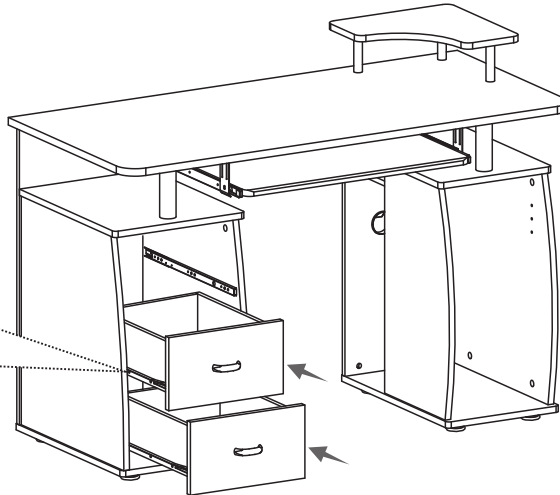
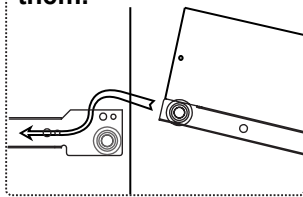

If the drawers stop and don't close completely, tighten all the screws inside as flushed as possible so the heads don't interfere with the rollers.

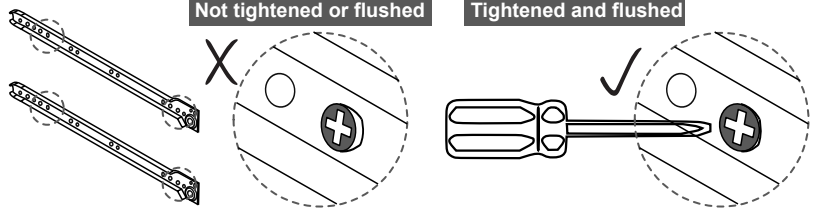

- Slide out the sliders 4 and with the help of another person, install the sliding shelf 11 with screws B from the sides.
- Insert the pins M into one of the 3 sets of holes on the side panels 16 and 18 according to your preference, and place the adjustable shelf 17.

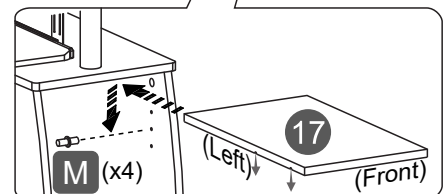
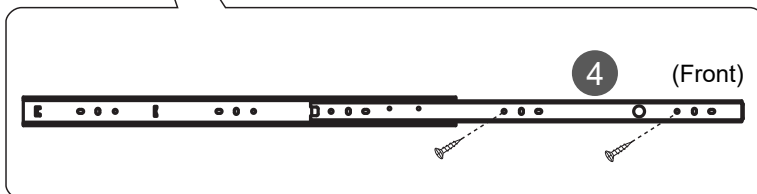
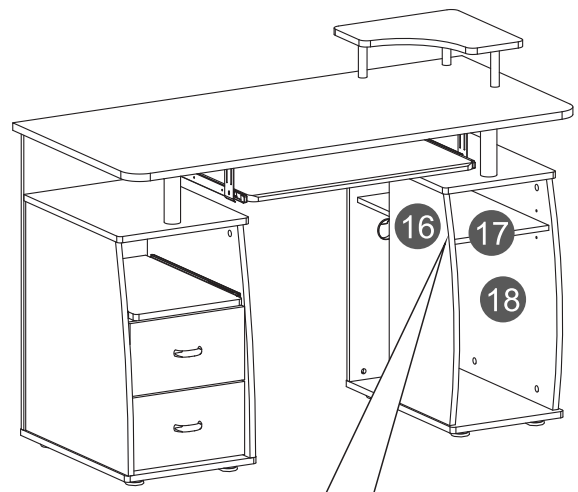
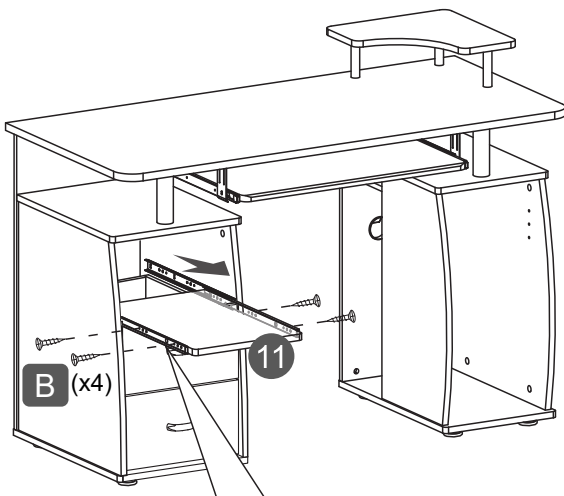

WEIGHT LIMITS

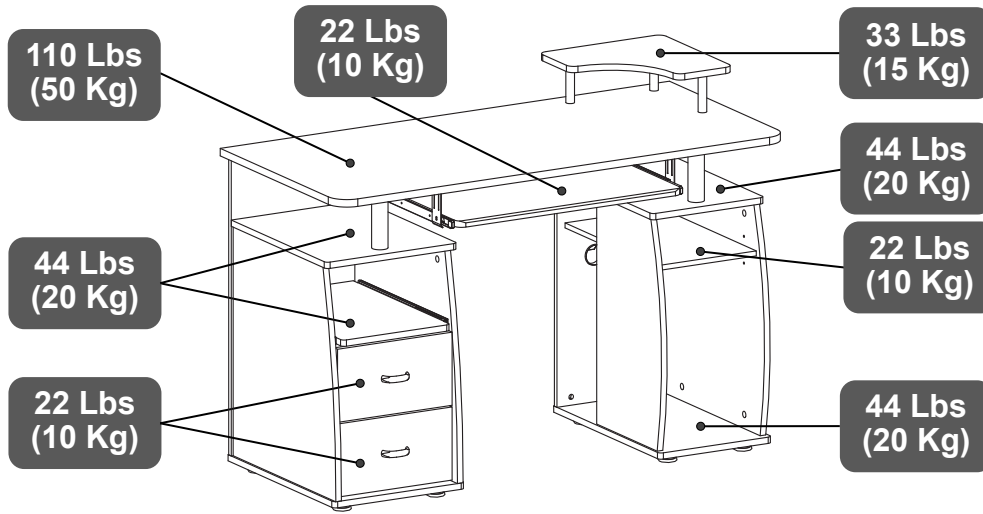

WARNINGS

- Do not exceed the indicated weight limits.
- Do not expose the surfaces to direct sunlight or to extreme environmental conditions.
- Do not use solvents or abrasive materials to clean the unit.
- Do not sit on the unit or lean against it.
- Do not allow small children to play under or over the unit.
- Do not allow small children to reach inside the drawers or compartments without your supervision.
- Do not pull, push or drag the unit to move it for more than 1 feet. The unit must be lifted by at least 2 persons when moving in the same or adjacent rooms.
- Before moving the unit, make sure to secure or remove any object that is heavy or might fall off.
- Please note that lifting from the tabletop with too much weight on the product might lead to part damage/separation.
- When lifting the unit, use both hands and bend your knees, not your backs.
- Do not use the product if screws are loose or missing, or if you notice damaged parts.
- The warranty does not extend to regular wear and tear, nor the manufacturer assumes liability for damages or consequences due to accidents, incorrect assembly, negligence, improper use, modifications, or not heeding the above warnings.

CARE AND MAINTENANCE

- Clean the surfaces preferable with a clean cloth damped in a solution of mild soap and water, then dry with a clean towel.
- If you decide to use a cleaning agent, test first on an area hidden from view such as underneath the tabletop.
- Every 4 months, inspect the unit completely and make sure that all screws are tighten.
- When transporting the unit to places far away, protect and secure the unit to avoid damage in transit.