



626-679-3588  
service@getprohome.com  
www.getprohome.com  
162 Atlantic St, Pomona, CA 91768

# INSTALLATION MANUAL

## DELUXE KITCHEN SINK



PRODUCT  
INSTRUCTION  
VIDEO

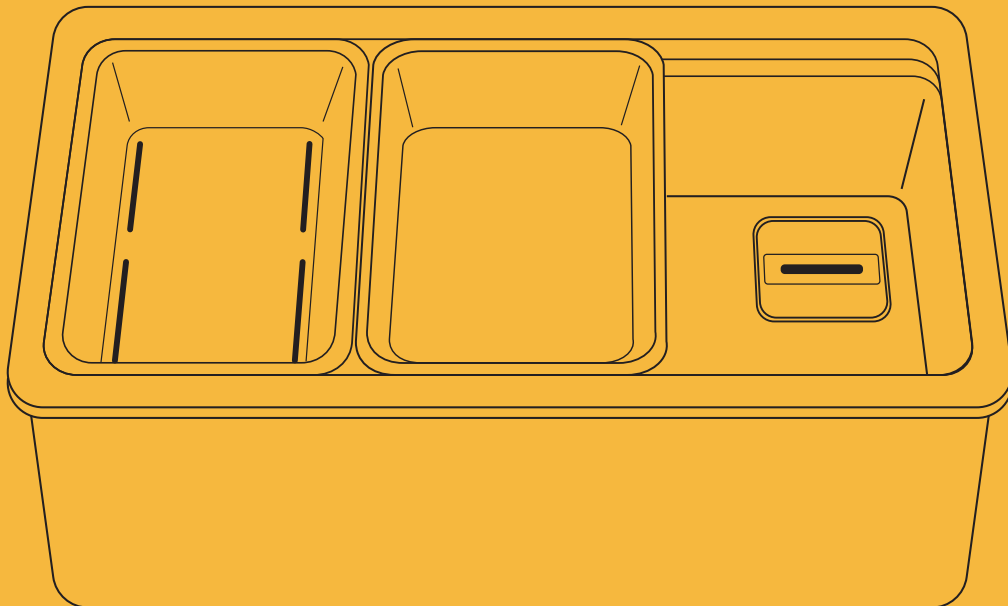

## Thank you for your purchase of our kitchen sink!

Please keep the box and packaging materials until your product is completely installed. If you have any questions, require technical assistance or have any problems with your product. Please contact our customer service team.



**DO NOT RETURN TO STORE**

### Please contact our Customer Service Team

 [service@bestgosupplychaininc.com](mailto:service@bestgosupplychaininc.com)  626 679 3588

Have the model number available and retain a copy of your receipt with purchase date for reference.

If for any reason this product does not meet your expectations, please be sure to repack this product in the original box and packaging material to avoid damage during transit.

# THANK YOU!

*Dear Valued Customer,*

*Thanks to your kind support of GETPRO, we hope our product can improve the quality of your life.*

*As our valued customer, your comments and opinions are very important to us. If you have any concerns, questions, or comments, we hope that you will bring them to our attention.*

*Please keep the carton and packaging materials until your product is completely installed.*

*Feel free to contact us if you encounter any problems such as missing parts, or product defects during the installation process. We are happy to provide you with the most sincere service.*

*Sincerely,  
Service Team*

# TOOLS AND MATERIALS

To install a drop-in kitchen sink, you will need the following tools and materials:



Tape Measure

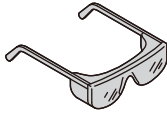

Eye Protector

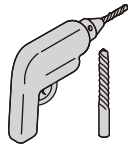

Power Drill

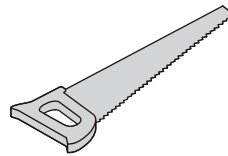

Hacksaw/Jigsaw

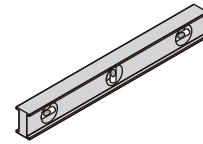

Level



Cleaning Rags

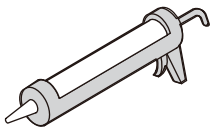

silicone adhesive sealant

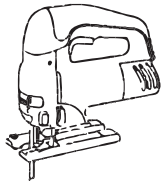

Jig Saw

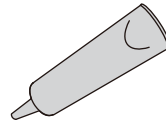

Silicone Sealant

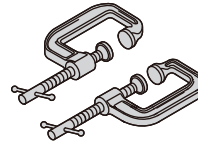

Framing Square



Pencil(NO ink)

**NOTE:** Specialized tools may be necessary to install BESTGO Kitchen sinks with countertop materials other than wood, marble or granite.

## Materials Included

- Kitchen sink
- Mini Sink
- Filter Sink
- Drain Cover
- Drain Assembly

## Extra Free Gift

- Cleaning Powder
- Scrub Pad

## INSTALLING AN DROP IN KITCHEN SINK, REQUIRES CAREFUL PREPARATION AND THE FOLLOWING STEPS

### 1. MEASURE AND PLAN

Measure the cabinet opening where the sink will be installed to ensure the kitchen sink fits properly. Plan for any modifications needed to accommodate the larger size of the sink.

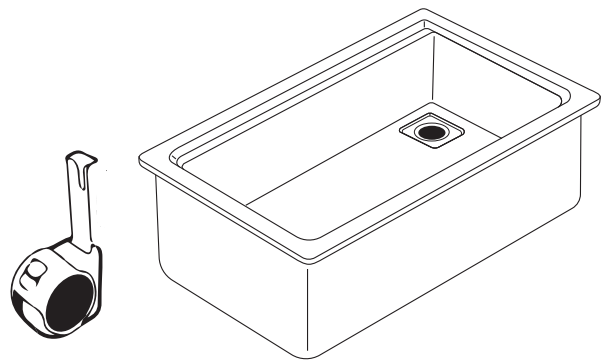

### 2. CUT COUNTERTOP

- Countertop Opening: Cut the opening in the countertop according to the specified dimensions.
- Edge Polishing: Polish the countertop edge with a 20mm width to ensure a smooth finish.

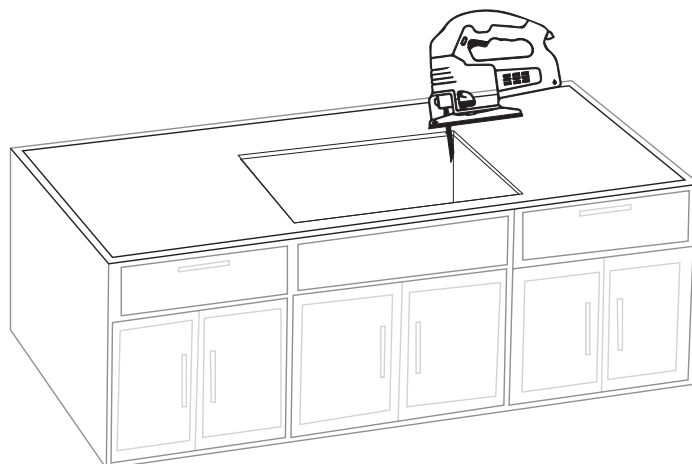

### 3. SUPPORT STRUCTURE(If Needed)

- **Bracket Installation:** install the supporting brackets on the cabinet wall to hold the sink securely.
- **Secure Brackets:** Fasten the brackets securely to ensure the sink is held in position.

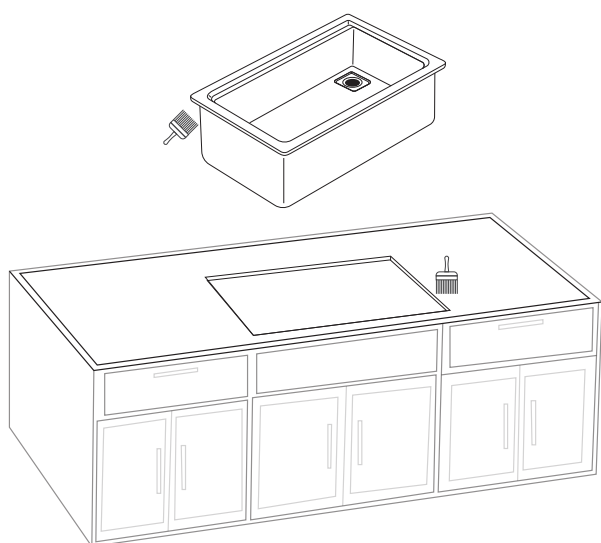
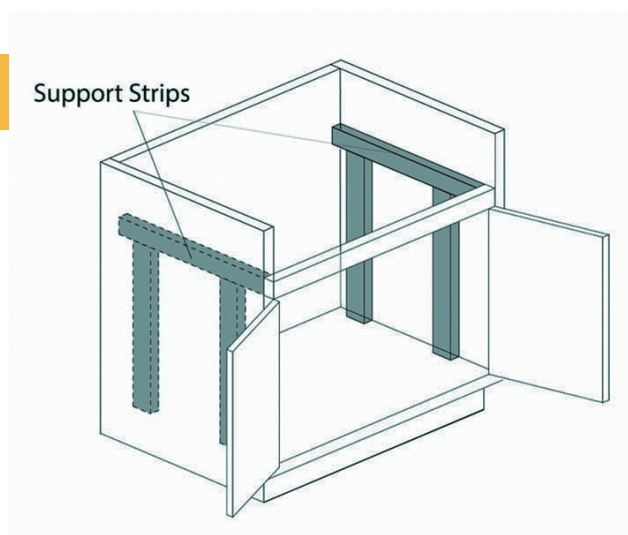

### 4. DUST OFF

Clean dirt and impurities from around countertops and under sinks.

### 5. INSERT SINK

- Use a bead of silicone (or preferred adhesive) around the rim of the sink.
- Carefully place the sink into the cutout opening from above.

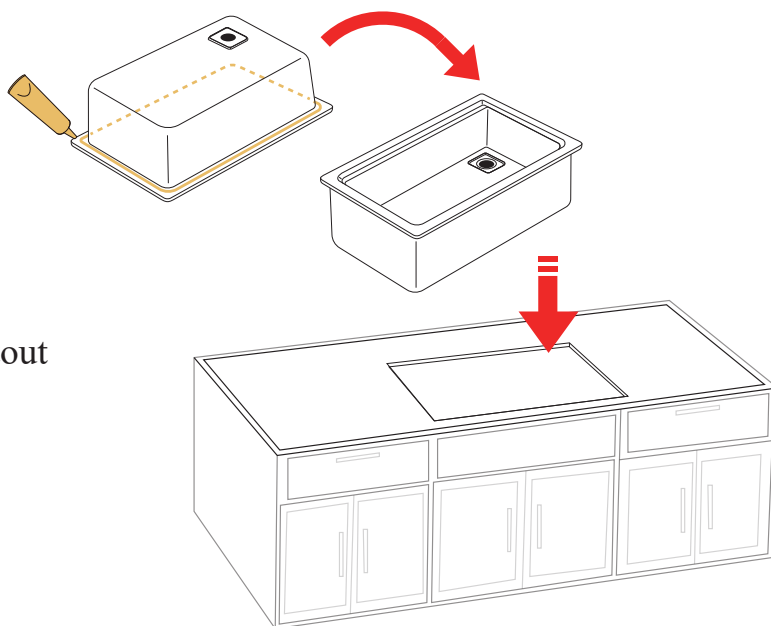

## 6. SEAL EDGES

Check the alignment of the sink to the cutout in the countertop.  
Apply a waterproof sealant around the edges to prevent water leakage.

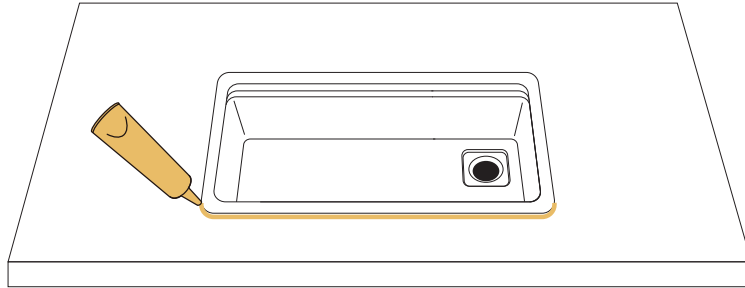

## 7. CLEANING SINK

Wipe off excess Silicone Sealant with a Cleaning Rags.

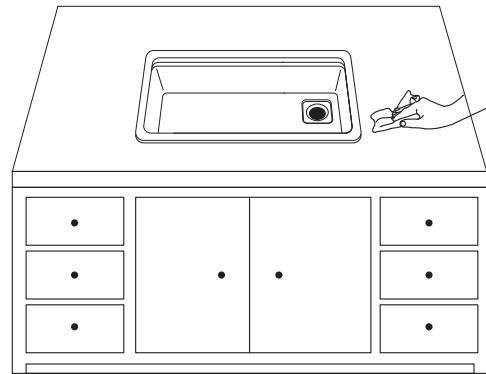

## 8. SINK FITTINGS INSTALLATION

Install the sink's drain and any additional plumbing components. Make sure the plumbing aligns with the sink's configuration.

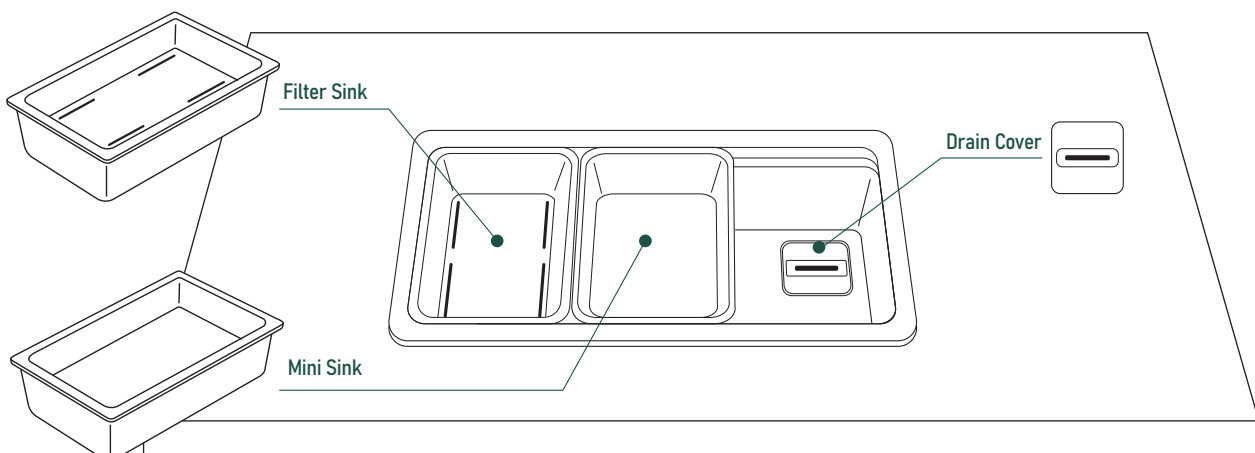

# STRAINER INSTALLATION GUIDE

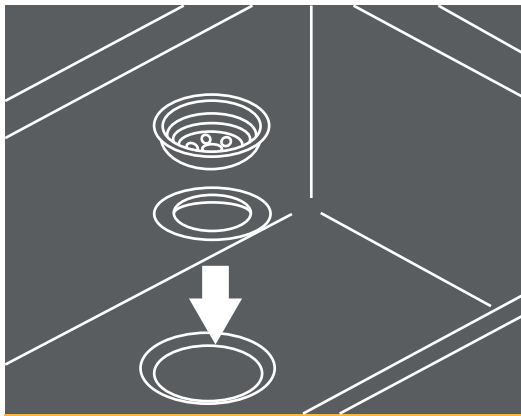

Step 1

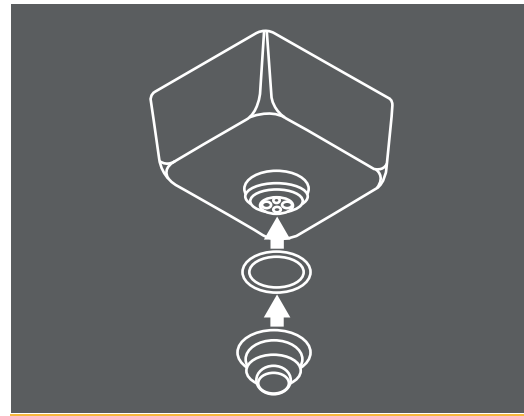

Step 2

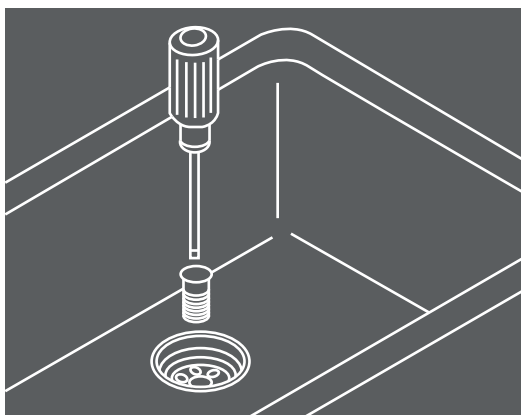

Step 3

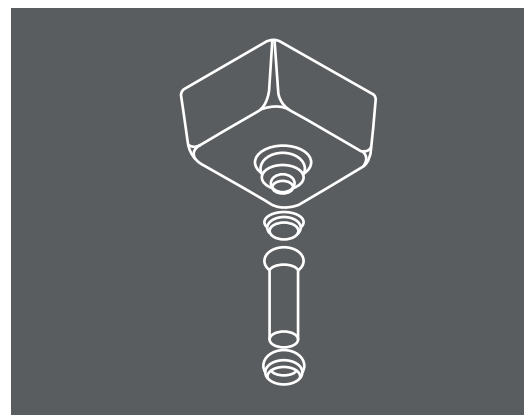

Step 4

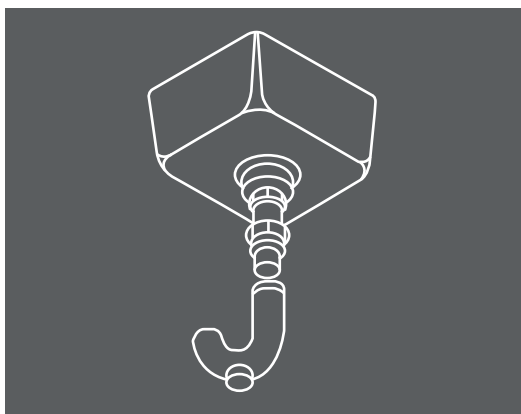

Step 5

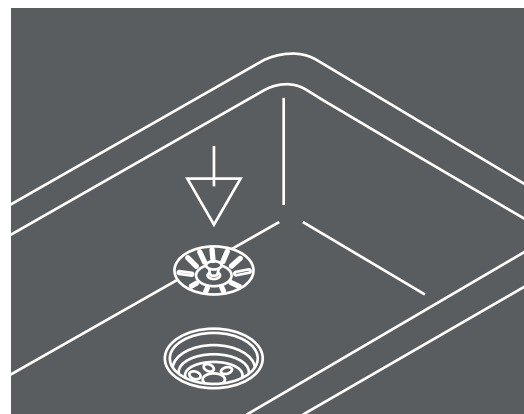

Step 6

# CARE & MAINTACE

## Proper Usage Instructions

### Avoid Corrosive Substances:

During renovations, take care to prevent corrosivedust, lime, and other substances from falling into the sink to avoid rust and stains

### Avoid High Temperatures:

Do not place hot cookware directly into a dry sink, as this can pose potential damage to the sink.

### Immediate Rinse for Chemicals:

If strong acids, bases, or other chemicals come into contact with the sink, rinse it immediately with water.

### Recommended Cleaning Materials:

When cleaning the sink, use a nano sponge or ascrub pad with a grit of 800-1000 for the best results, and avoid using steel wool to clean the surface.

### Repair Deep Scratches:

For deep scratches, you can use a scrub pad with a grit of 800-1000 to sand down and repair the surface of the sink.

### Cleaning Stubborn Stains:

- Method One: For stubborn rust, scale, tea stains, or grease that are difficult to clean due to long-term neglect, use a scrub pad with a grit of 800-1000 along with regular dishwashing detergent for repeated scrubbing until clean.
- Method Two: Use dishwashing powder for cleaning or Use the cleaning powder which we offered. (Pour the cleaning powder into the dry sink first, then add hot water above 80 degrees Celsius (note: mix 100 grams of cleaning powder with 2 liters of hot water above 80 degrees). Let it soak for 20 minutes for effective cleaning. (We offer a bag with the sink as gift to you, if you need more, please contact our customer service.)

## HOW TO REMOVE MINOR CUTS OR SCRATCHES?

Minor cuts or scratches on our kitchen sink can be repaired with the right techniques and products. Here is a general guide on how to repair scratches for the kitchen sink.

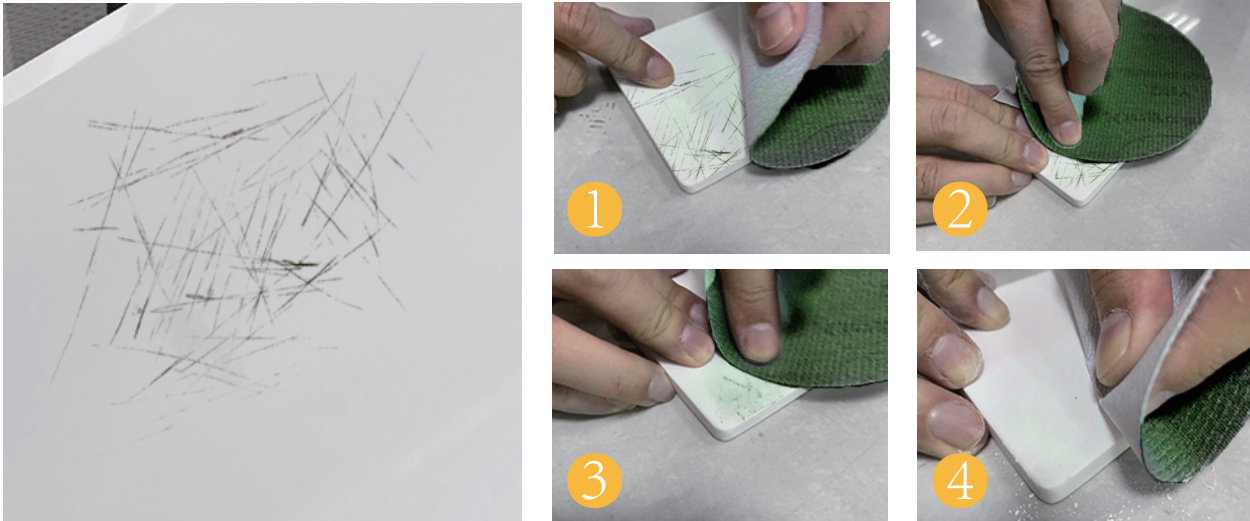

1. Remove the scratch with fine grit sanding pad (approximately 800-1000 qrmt). Rub over scratch in a straight line, not circular motion to remove it.

★ Periodically switch rubbing direction 90°. Be sure the entire scratch is removed and shape appropriately to match the surrounding area.

2. If the 800-1000 qrmt sandpaper cannot remove it, try the next heaviest grit sanding pad. To minimize dust during sanding, wet the surface. Rinse pad periodically to clean residue.

★ Clean surface with water. Select the next heaviest grit until desired level is achieved.

## HOW TO REMOVE WATER STAINS OR STUBBORN STAINS?

### 1. Water stain, blot

- ★ Clean with damp cloth and wipe dry.
- ★ Most dirt and residue can be rinsed with soapy water or mild ammonia cleaner and wiped dry.
- ★ If the residue still on it, pls repeat the second step again. If the residue cannot be removed by soapy water or cleaner, please try to remove it by sandpaper.
- ★ Occasionally wipe surface with a household bleach dilution(50 parts water/1 part bleach). Rinse sink thoroughly with water and wipe dry.
- ★ Do not use abrasive cleaners or cleaners containing strong acids, alkalis or strong ammonia to remove stains.



# LIMITED WARRANTY COVERAGE

## 1 YEARS LIMITED WARRANTY

GETPRO products are made with quality materials and excellent craftsmanship to provide the customers a long-lasting product. In the case of any defects in materials or craftsmanship under regular use were inspected in the first one year of delivery, GETPRO will provide replacement parts at no charge, or at its option, replace any product or part of the product that is deemed defective, under normal installation, use, service and maintenance. This warranty applies only to the original purchaser. Proof of purchase will be required in the case of a claim.

## BESTGO will, as its option

- (1) Repair or replace the defective part(s) or product(s) at no charge;
- (2) Issue a refund of the original purchase price of the product(s) (Valid within 30 days from the date of delivery);
- (3) Issue a credit to be applied toward the purchase of a new GETPRO product shipping/delivery charges may apply and are in GETPRO's sole discretion.

GETPRO recommends the installations to be made by a licensed, professional plumber. GETPRO will not be held responsible for any damage or product failure due to improper installation, misuse, or failure to use a licensed professional. GETPRO is not responsible for any removal or installation cost.

This limited warranty shall not apply to goods that have been subject to accident, negligence, improper installation, product abuse, product misuse, or use of cleaners containing abrasives, alcohol or other organic solvents, whether performed by a contractor, service company, or yourself, are excluded from this warranty.

GETPRO responsibility under this limited warranty is limited to only to replacement parts and no other costs.

GETPRO will not be responsible for labor charges and/or damage incurred by installation, repair, or replacement, nor for any indirect incidental or consequential damages, losses, injury, or costs of any nature relating to this product.

Except as provided by law, this limited warranty is instead of and excludes all other warranties, conditions, and guarantees, whether expressed or implied, statutory or otherwise, including without restriction those merchant ability of fitness for use.

## RESPONSIBILITIES OF OTHERS

Inspecting the unit before installation is the responsibility of the installer or building contractor who acts on behalf of the user. They are responsible for ensuring the unit is free of defects or damage. Notices are placed on and in the unit and on the shipping carton advising the installer of this responsibility. In the event of a problem, the unit must not be installed.

GETPRO is not responsible for failures or damage that could have been discovered, repaired, or avoided by proper inspection and testing before installation.

Damage occurring in transit is the responsibility of the carrier. The user or installer **MUST** open the crate and inspect the unit for damage when it's delivered. If damage is discovered, it must be reported immediately to the seller and the carrier in writing, and an inspection requested. Failure of the carrier to respond should be reported to the seller and the carrier. Your freight claims should be filed promptly thereafter.

## LIMITATIONS AND EXCLUSIONS

This warranty does not cover instances of negligence, misuse, abuse, improper installation, carelessness, accident, hard water or mineral deposits, exposure to corrosive materials, misapplication, damages caused by improper maintenance, alteration of the product, or failure to follow care or installation instructions enclosed with your product.

This warranty is void if the GETPRO is subject to alteration, or if repairs are attempted by anyone other than an authorized agent of GETPRO. This warranty does not extend to plumbing or components installed by dealers, installers or by any party other GETPRO.

GETPRO will not be liable for loss of use of the GETPRO inconvenience, or any other incidental or consequential costs, expenses, or damages. Please note that some states do not allow the exclusion or limitation of incidental damages.

## DISCLAIMER

Except as expressly provided, there shall be no warranty or obligation, express or implied, oral or statutory. No dealer or other person has the authority to make any warranties or representations concerning GETPRO or its products. In no event shall GETPRO be held responsible for any such warranties or representations.

## WARRANTY SERVICE

NOTE: When requesting a warranty, be sure to have the following:

- Copy of original invoice
- Date of installation
- Description and pictures of the defect
- Model number or description of the model

To obtain warranty service and replacement parts, please contact GETPRO Customer Service. GETPRO will determine whether to repair or replace your product, issue a refund, or issue a credit.

WARNING: Content may contain sharp and other possibly harmful pieces and may cause hazard to children and adults, GETPRO is not responsible in any way for personal damage.

## Model : BG2719K

Sink Dimensions: 27" x 19" x 10"

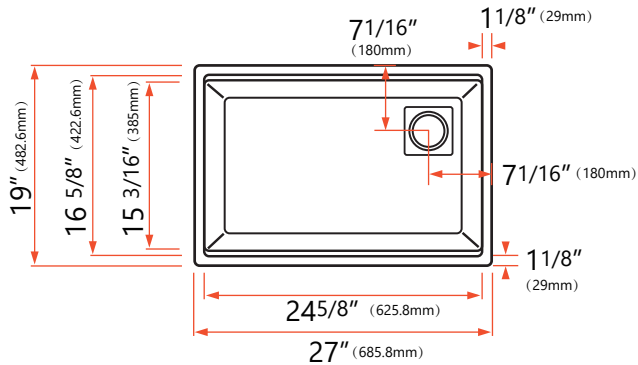

TOP VIEW

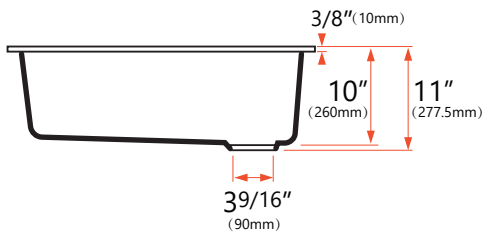

FRONT VIEW

## Model : BG3019K

Sink Dimensions: 30" x 19" x 10"

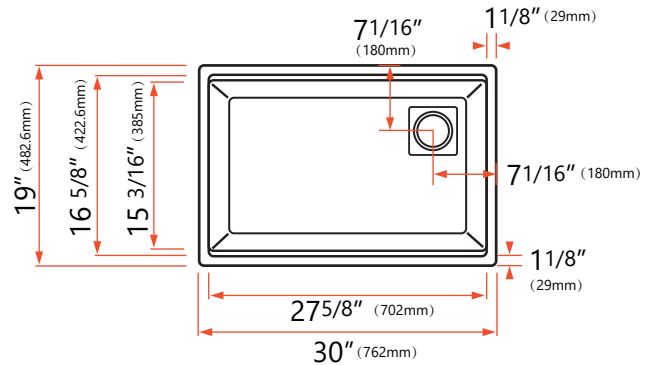

TOP VIEW

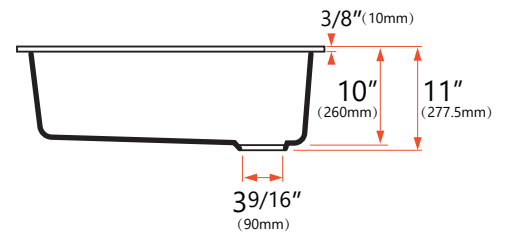

FRONT VIEW

## Model : BG3319K

Sink Dimensions: 33" x 19" x 10"

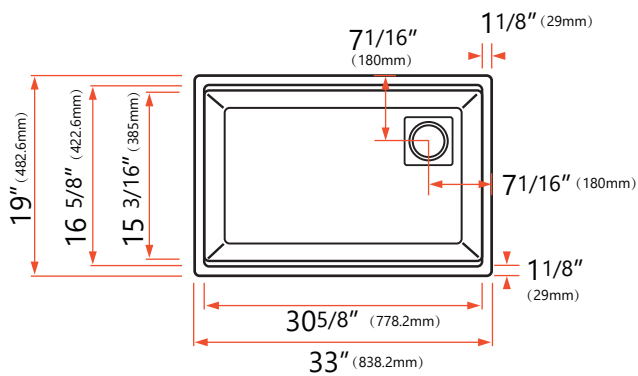

TOP VIEW

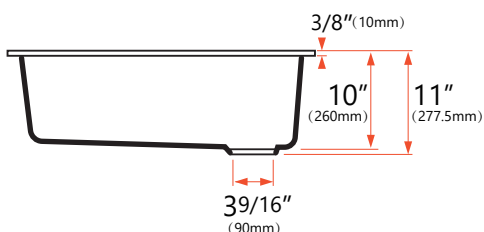

FRONT VIEW

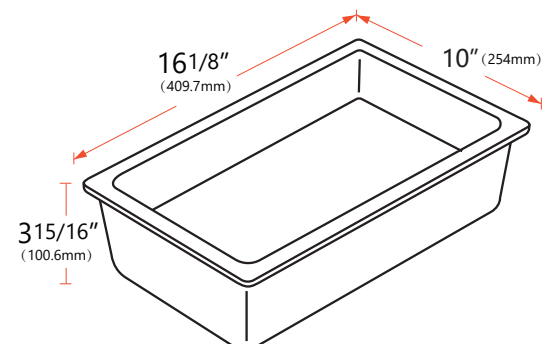
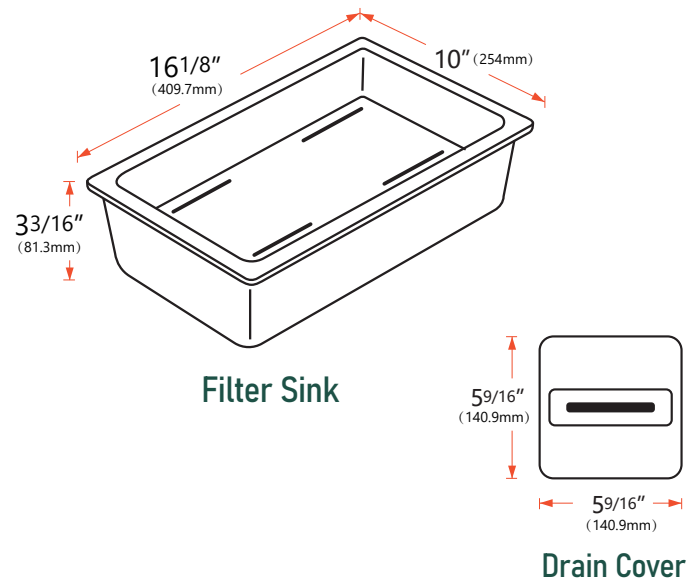

# HOME SERVICES



INSTALLATION VIDEO

**Missing Part or Defective?**

Please Contact the Customer Service Team

✉ [service@getprohome.com](mailto:service@getprohome.com)

☎ 626 679 3588