

"IMPORTANT, RETAIN FOR FUTURE REFERENCE: READ CAREFULLY"

German: WICHTIG, FÜR SPÄTERE NACHSCHLAGE AUFBEWAHREN: SORGFÄLTIG LESEN

Spanish: IMPORTANTE, GUARDAR PARA REFERENCIA FUTURA: LEER ATENTAMENTE

Italian: IMPORTANTE, CONSERVARE PER RIFERIMENTI FUTURI: LEGGERE ATTENTAMENTE

French: IMPORTANT, À CONSERVER POUR RÉFÉRENCE FUTURE : LIRE ATTENTIVEMENT



Attention: Do not tighten the screws until you have completed the assembly.

1. Please be aware that the drawer storage towers are lightweight, so pulling them down could be dangerous, especially when children are playing and chasing each other around the drawers.

2. Professional installation is highly recommended.

Achtung: Ziehen Sie die Schrauben erst an, wenn Sie den Aufbau abgeschlossen haben.

1. Bitte beachten Sie, dass die Lagertürme mit Schubladen sehr leicht sind, so dass sie einfach heruntergezogen werden können, wodurch Gefahren verursacht werden, insbesondere wenn Kinder damit spielen und sich herumjagen.

2. Ein fachgerechter Einbau wird dringend empfohlen.

Remarque: Ne serrez pas les vis avant d'avoir terminé l'assemblage.

1. Veuillez noter que les tours de rangement des tiroirs sont légères, il peut donc être dangereux de les abaisser, surtout lorsque les enfants jouent et se poursuivent autour des tiroirs.

2. Une installation professionnelle est fortement recommandée.

Attenzione: Non serrare le viti fino a quando non si è completato il montaggio dell'installazione.

1. Tenere presente che le torri di stoccaggio dei cassetti sono leggere, quindi tirarle verso il basso potrebbe essere pericoloso, specialmente quando i bambini giocano e si rincorrono intorno ai cassetti.

2. Si consiglia vivamente un'installazione professionale.

Atención: No apriete los tornillos hasta que haya completado el montaje de la configuración.

1. Tenga en cuenta que las torres de cajones son ligeras, por lo que puede ser peligroso bajarlas, especialmente cuando los niños juegan y persiguen alrededor de los cajones.

2. Se recomienda encarecidamente la instalación profesional.

Item no. Nr. N° d'article Articolo No. Artículo No.	Reference Image Referenzbild Image de référence Immagine di riferimento Imagen de referencia	Qty. Menge Qté. Qtà Cant.	Item no. Nr. N° d'article Articolo No. Artículo No.	Reference Image Referenzbild Image de référence Immagine di riferimento Imagen de referencia	Qty. Menge Qté. Qtà Cant.
1		X1	8		X1
2		X1	9-1		X2
3		X1	9-2		X3
4		X2	10		X5
5		X4	11		X10
6		X8	12		X5
7		X8	13		X2
			14		X2
			15		X2
			16		X1
			17		X1

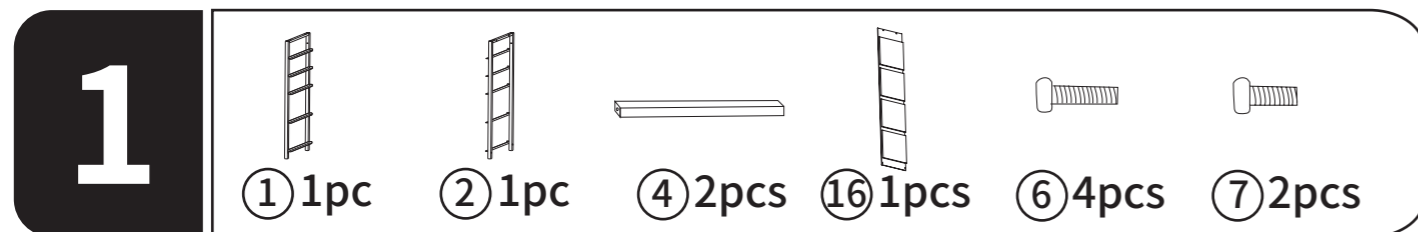

Confirm that the iron frames are well-placed and facing the correct direction. Per the below picture, the holes marked by triangles on Part ① and Part ② should face the same direction.

Stellen Sie sicher, dass die Eisenrahmen richtig platziert sind und in die richtige Richtung zeigen. Die durch Dreiecke markierten Löcher auf Teil ① und Teil ② sollten in die gleiche Richtung zeigen.

Vérifiez que le cadre du fer est dans la bonne position et orientation. Suivant le schéma ci-dessous, les trous marqués de triangles dans la partie ① et la partie ② doivent être orientés dans la même direction.

Verificare che i telai di ferro siano posizionati correttamente e rivolti nella direzione corretta. Come Nella figura seguente, i fori contrassegnati da triangoli sulla Parte ① e sulla Parte ② dovrebbero essere rivolti nella stessa direzione.

Coloque y oriente el marco de hierro correctamente. Según la imagen siguiente, los agujeros marcados con triángulos en la parte ① y la parte ② deben estar orientados en la misma dirección.

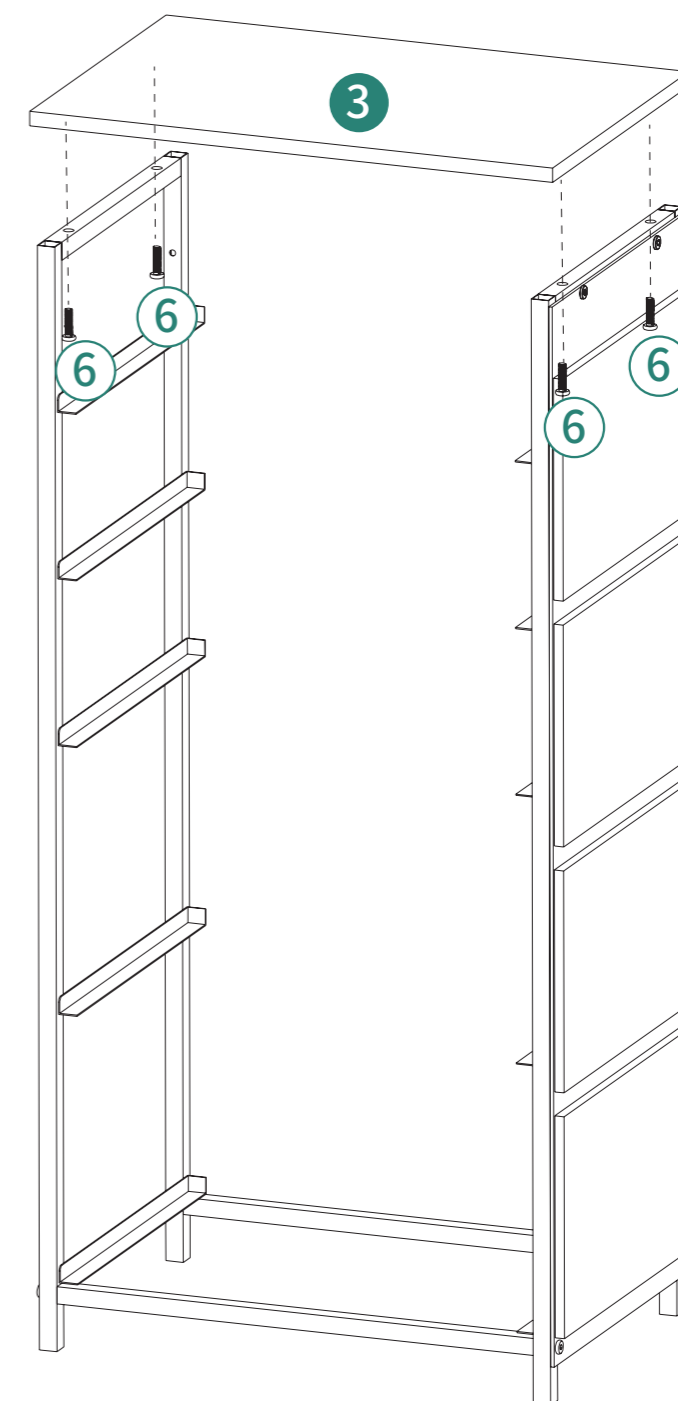
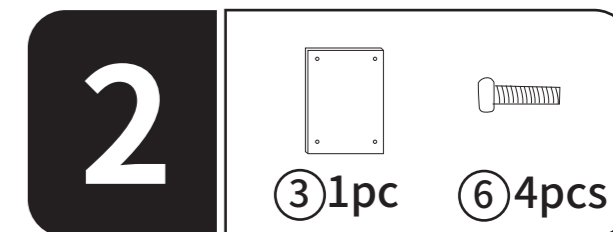
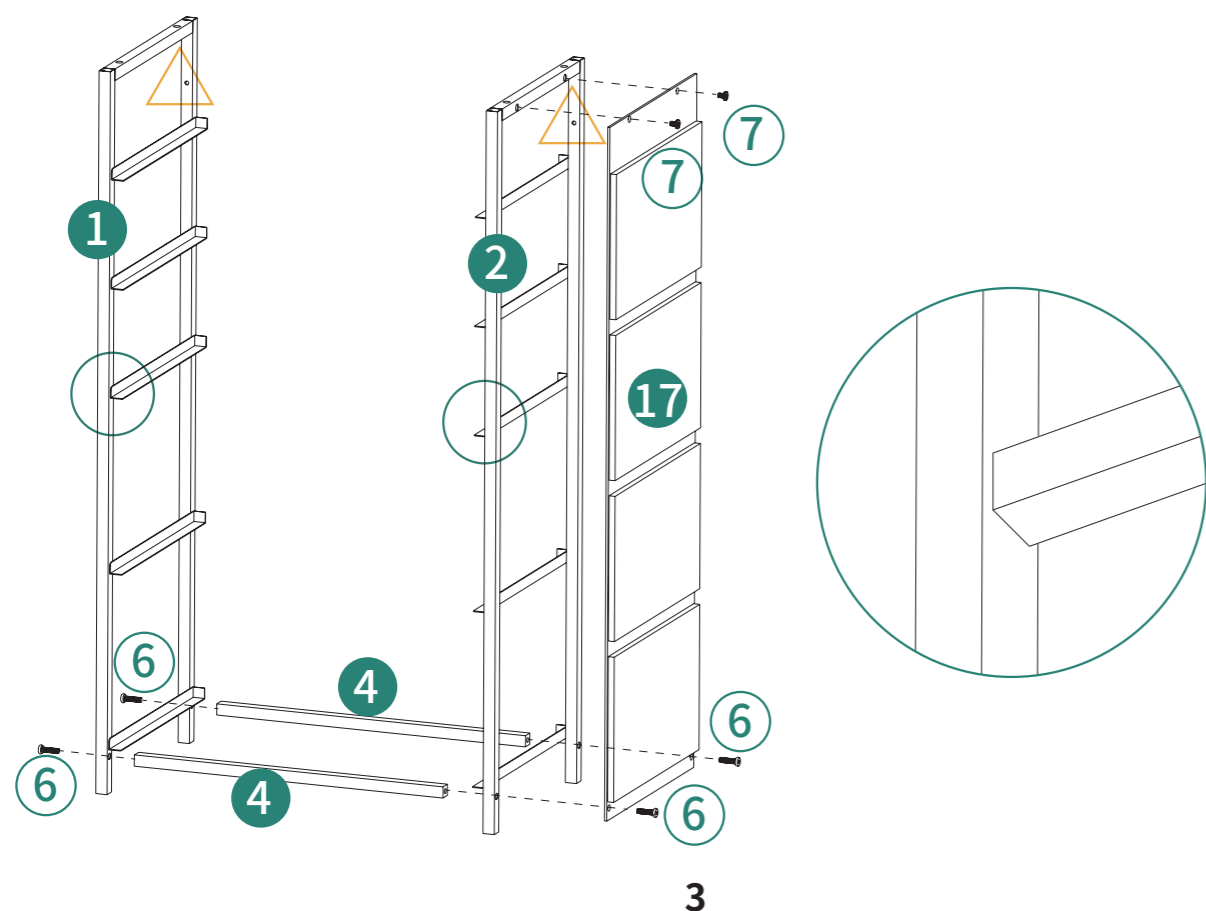

3



⑤ 4pcs

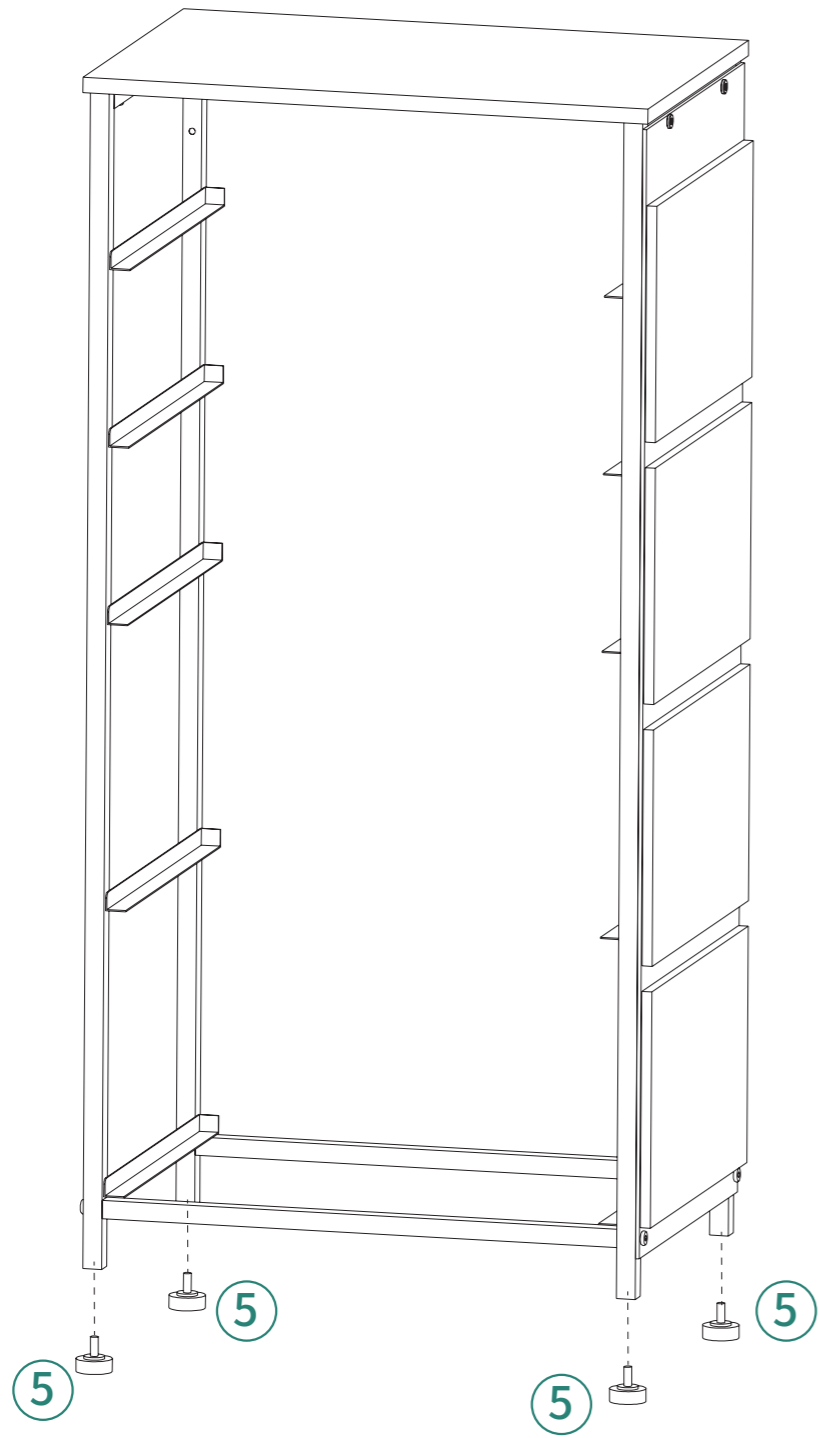

5

4



⑰ 1pcs



⑦ 4pcs

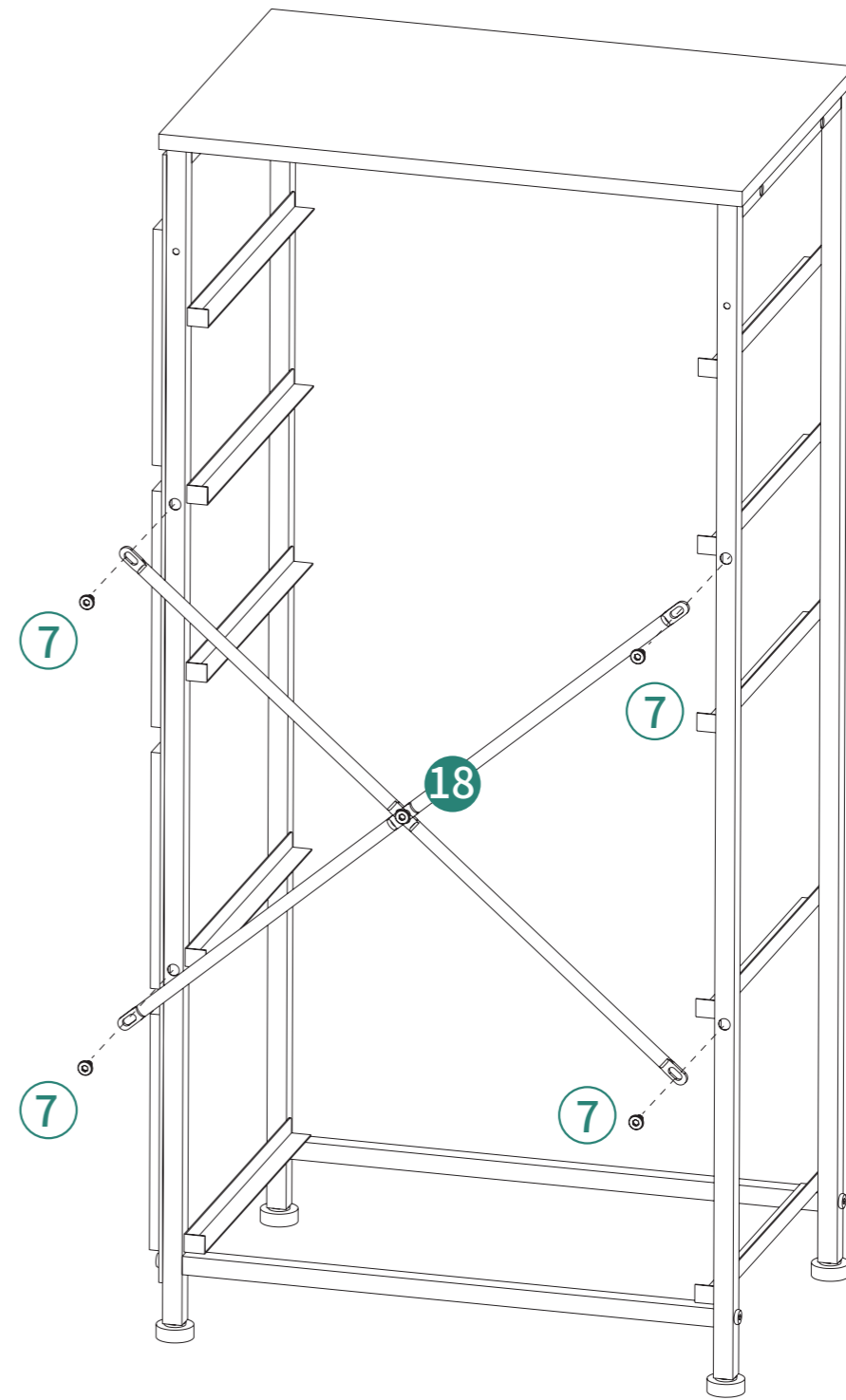

6

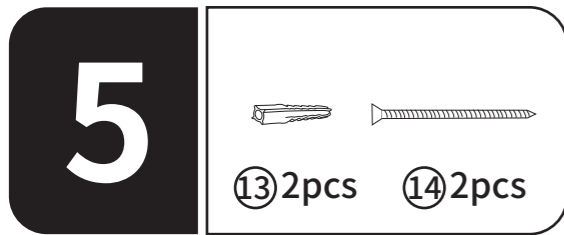

Attention: For safety and stability, we suggest you have to secure the anti-tip accessories to the wall to prevent tipping, injury, and property damage.

Achtung: Aus Sicherheits- und Stabilitätsgründen empfehlen wir, das Anti-Kipp-Zubehör an der Wand zu befestigen, um Kippen, Verletzungen und Sachschäden zu vermeiden.



Attention: Pour plus de sécurité et de stabilité, nous vous recommandons de fixer l'attache de pointe au mur pour éviter le déversement, les dommages et les dommages matériels.

Attenzione: Per assicurare sicurezza e stabilità, ti consigliamo di fissare al muro gli accessori anti-ribaltamento per prevenire rovesciamenti, lesioni o danni ai beni.

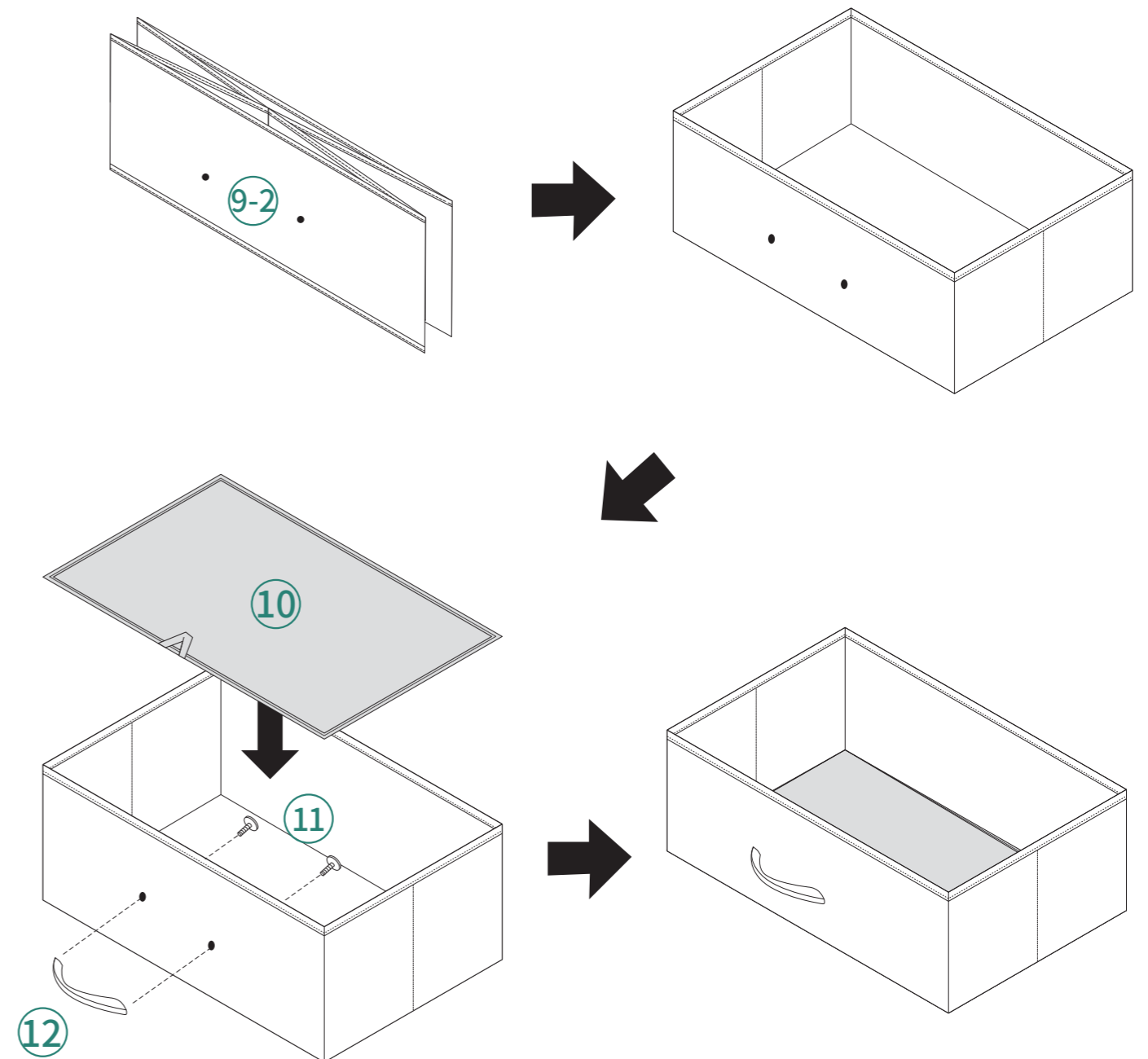
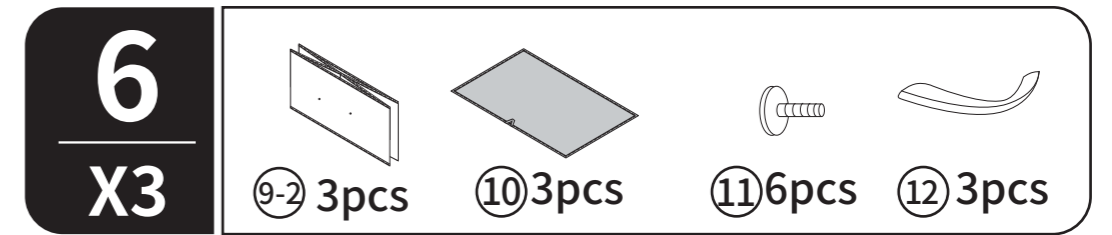
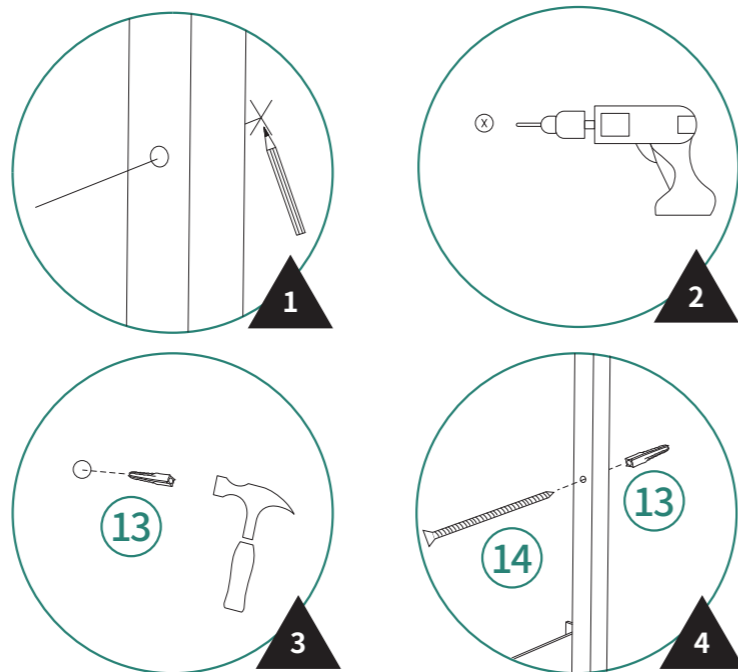
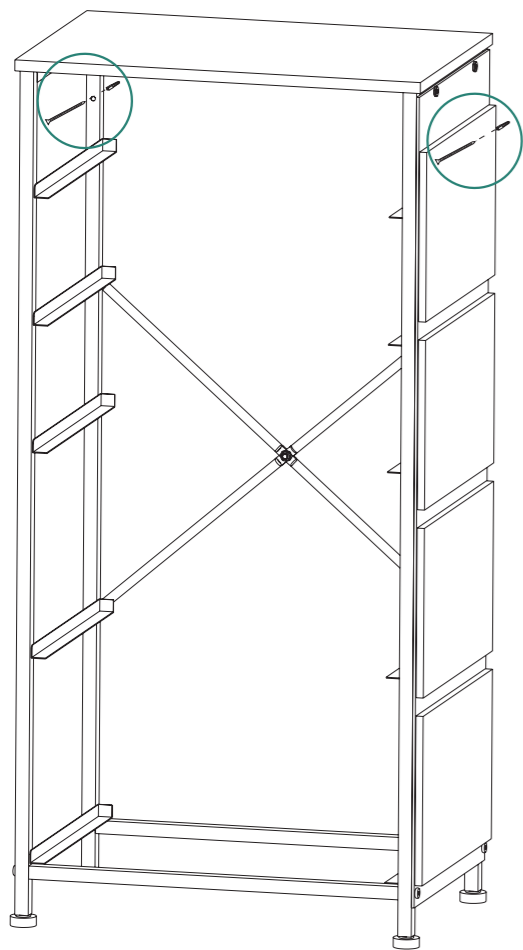
Atención: Por seguridad y estabilidad, le sugerimos que coloque los accesorios de fijación a la pared para evitar vuelcos, lesiones y daños a su propiedad.

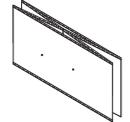
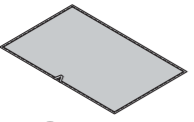

7
X2

-  ⑨-1 2pcs
-  ⑩ 2pcs
-  ⑪ 4pcs
-  ⑫ 2pcs

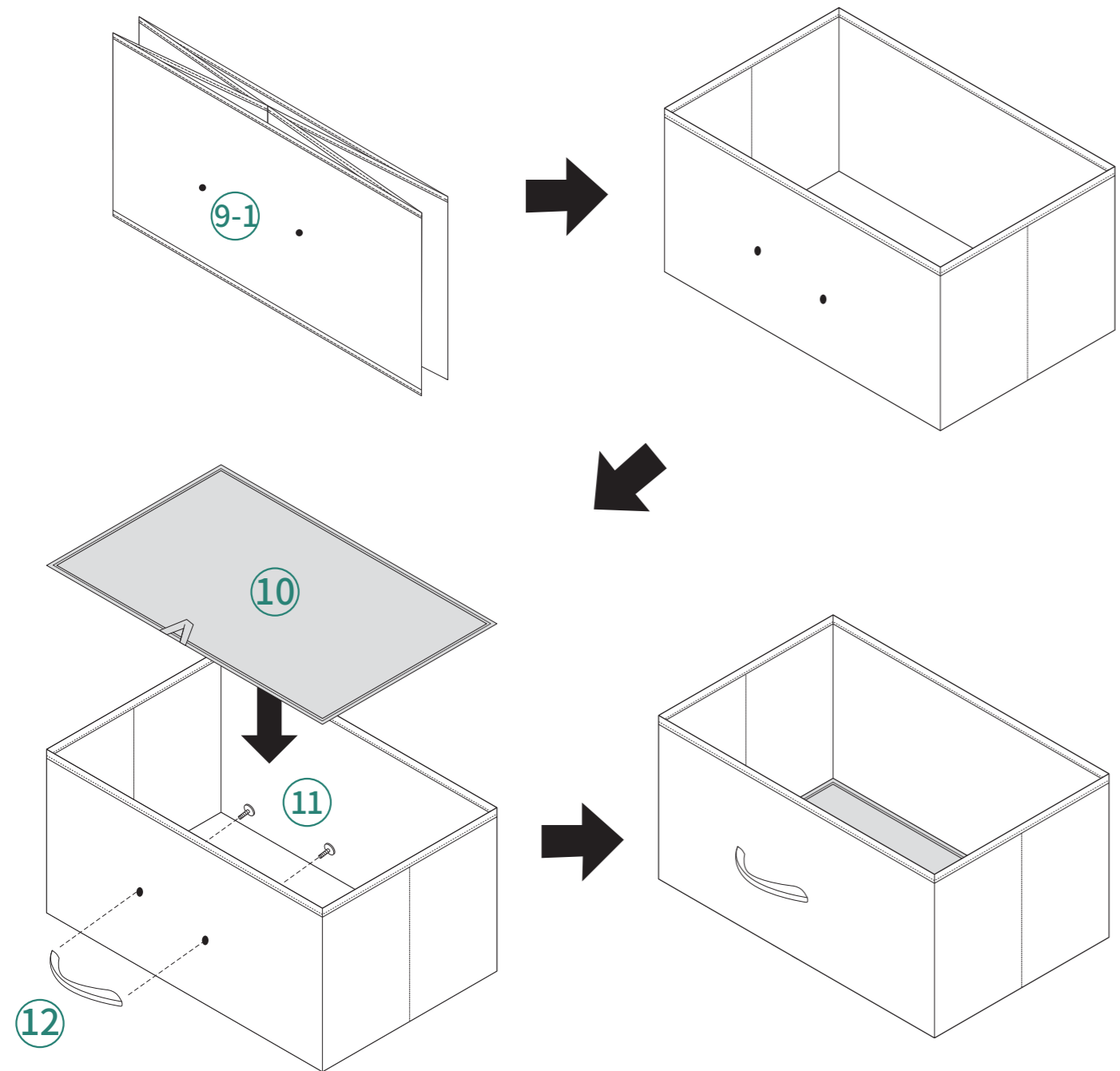

8

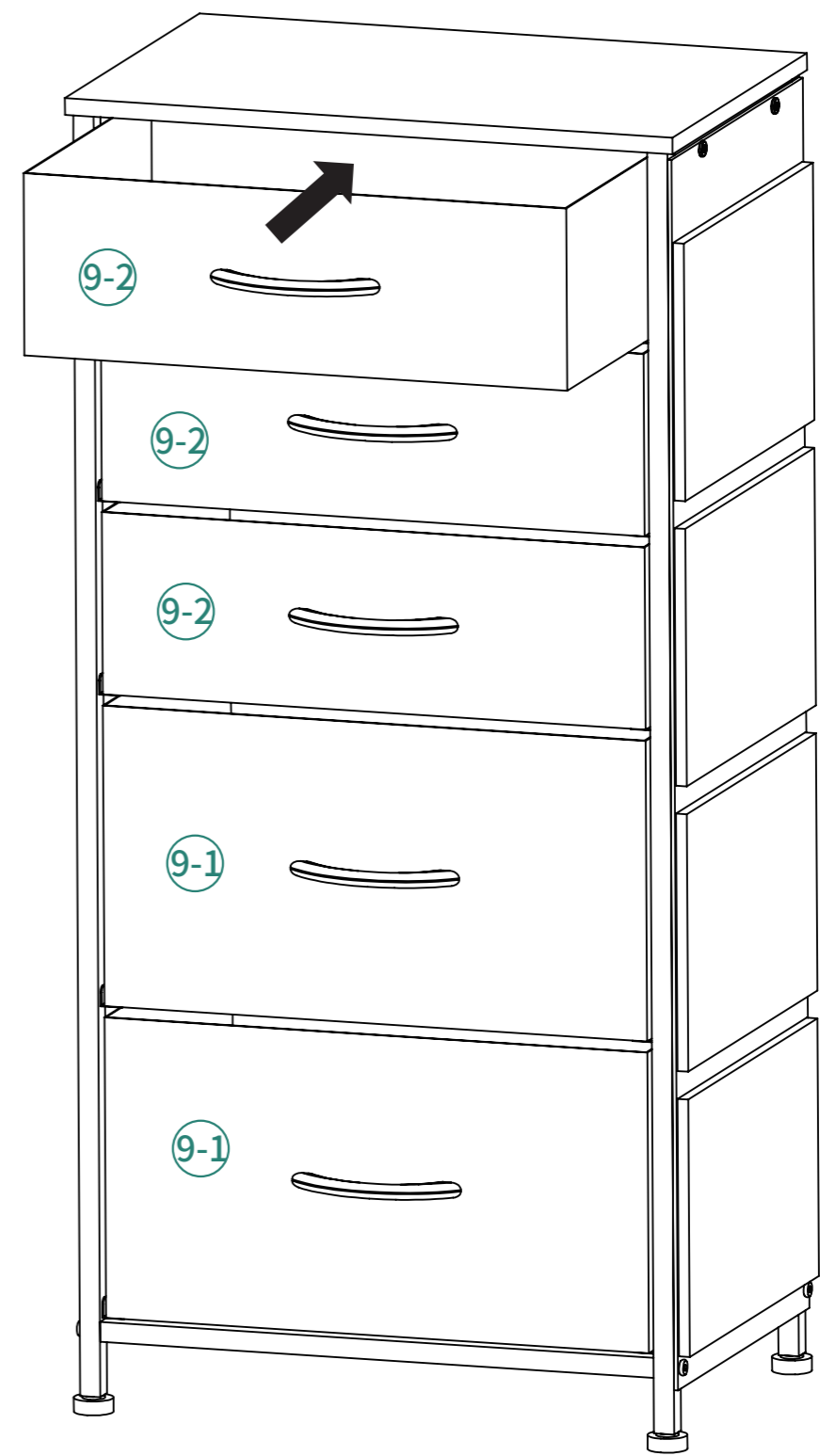

9

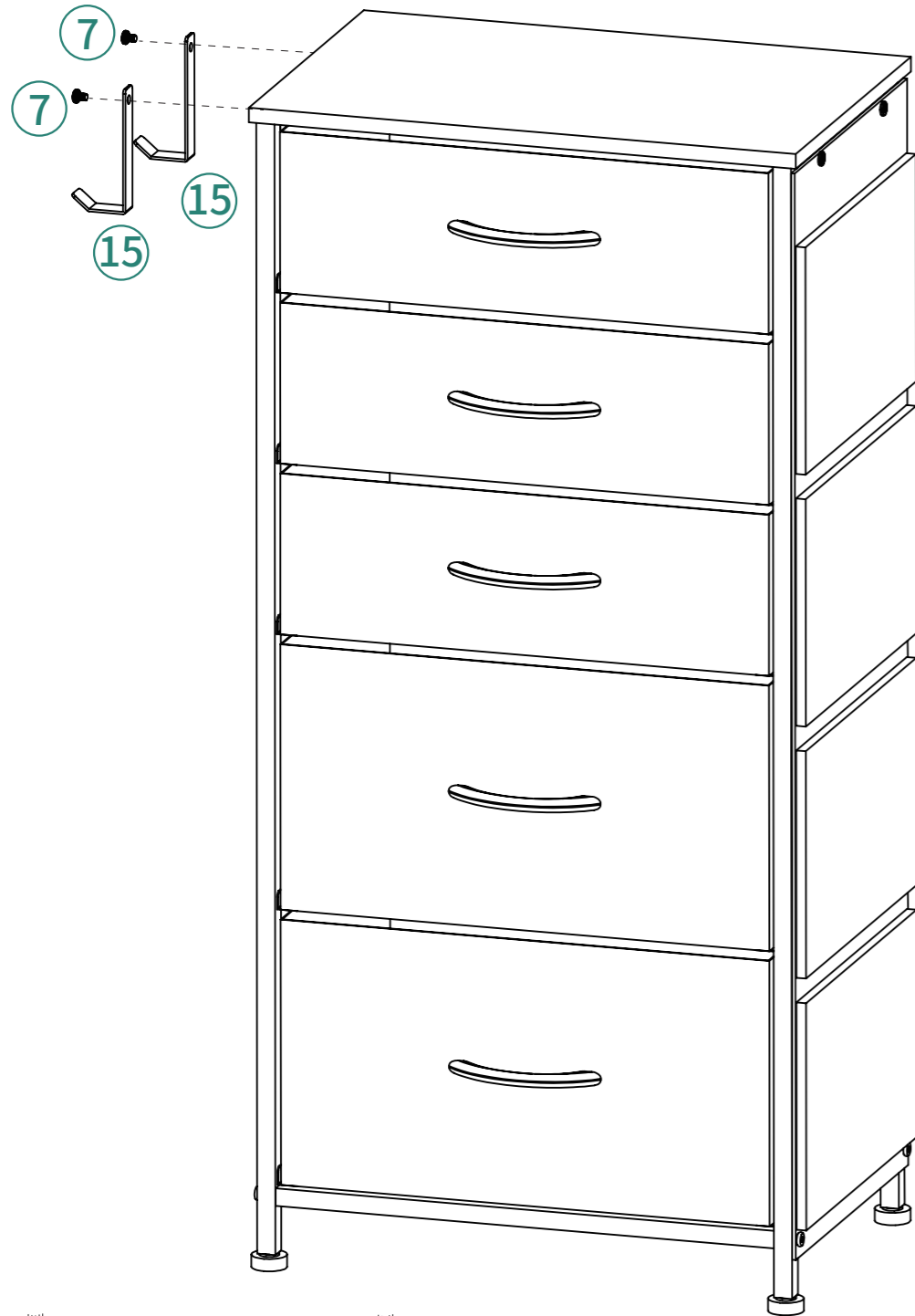
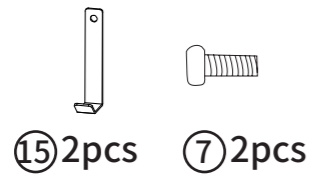

11

10

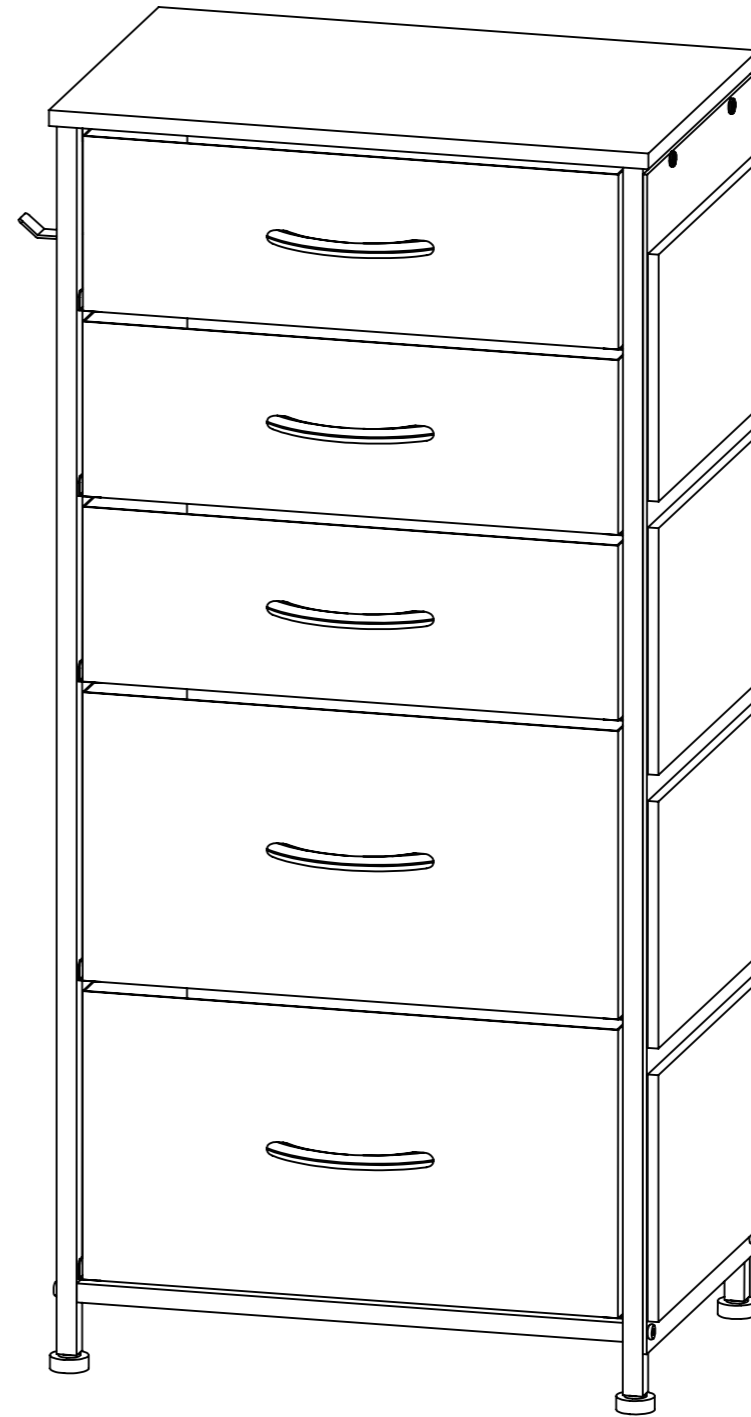

Installation Completed

Installation abgeschlossen

Installation complétée

Installazione completata

Instalación completada

12