

DGSTD

FTLFTS-6107-E  
FTLFTS-6108-E  
FTLFTS-6109-E

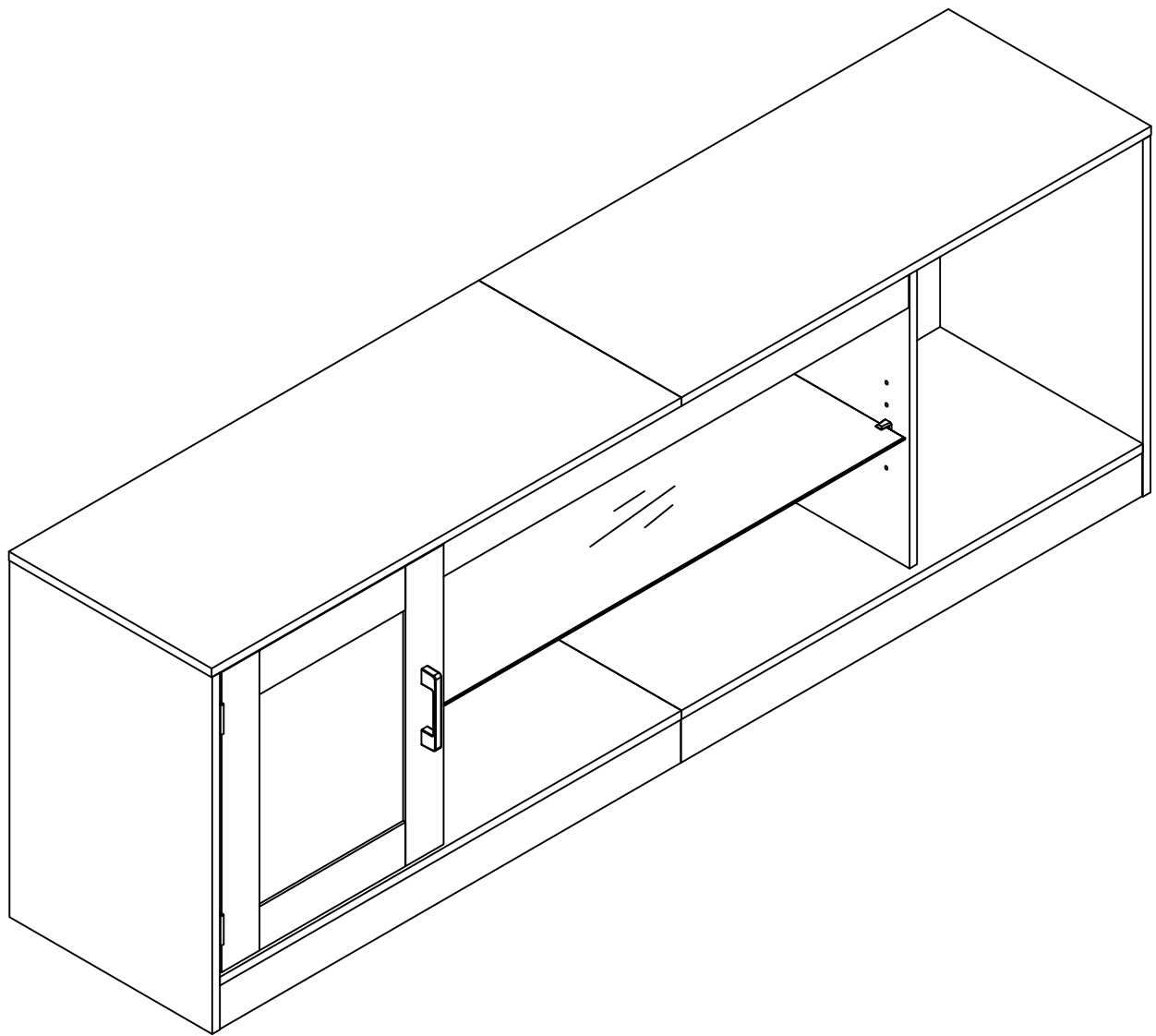

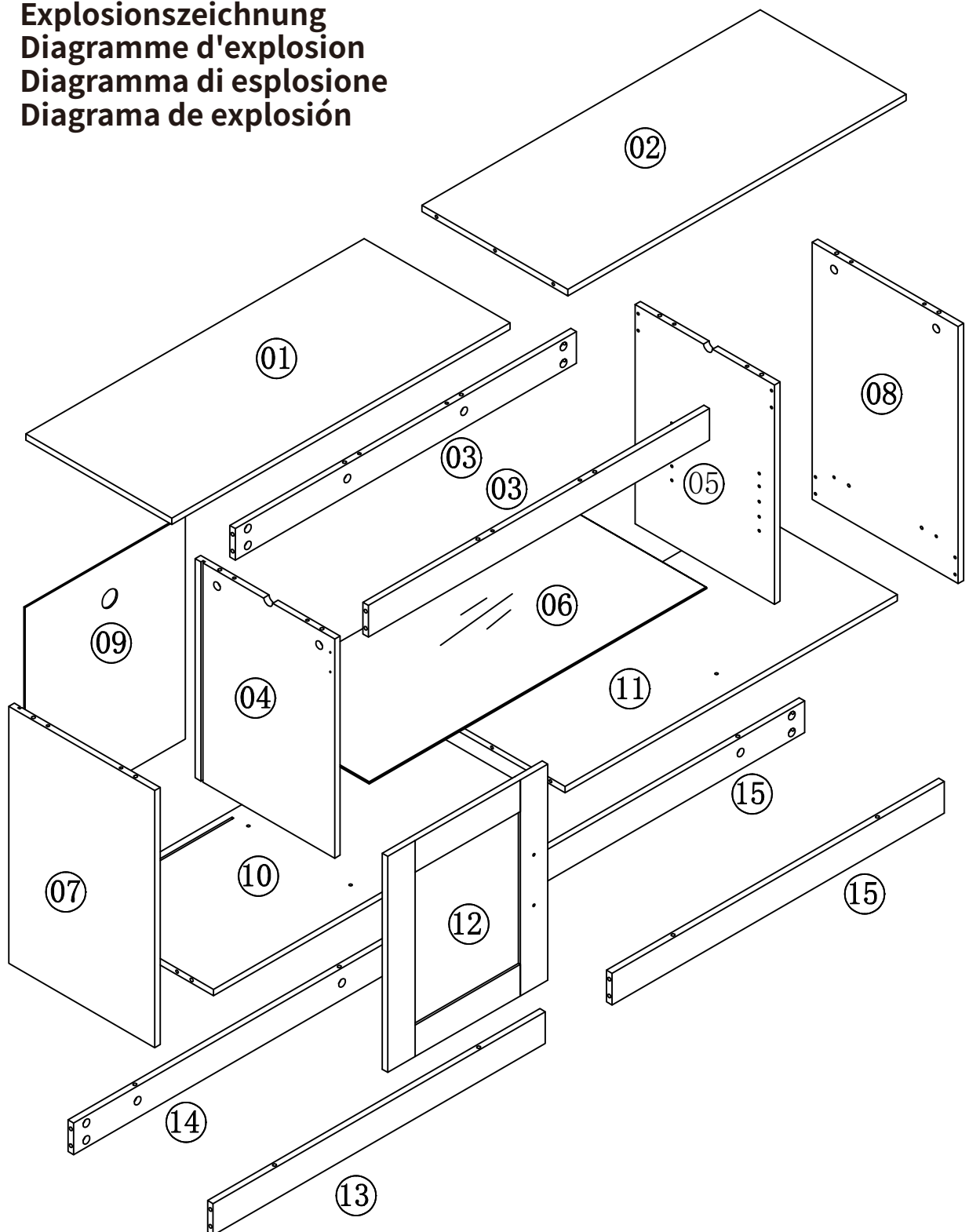

Explosion diagram  
Explosionszeichnung  
Diagramme d'explosion  
Diagramma di esplosione  
Diagrama de explosión

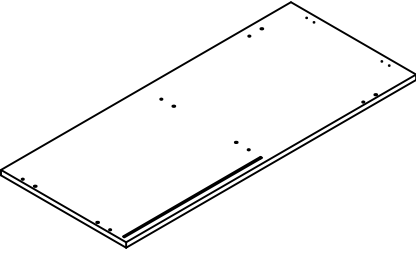
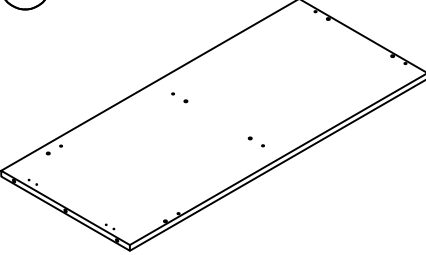
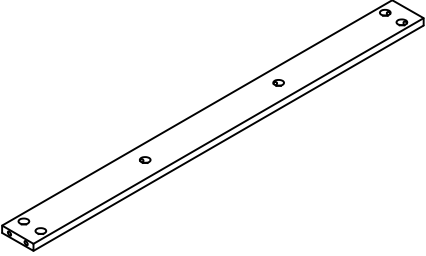
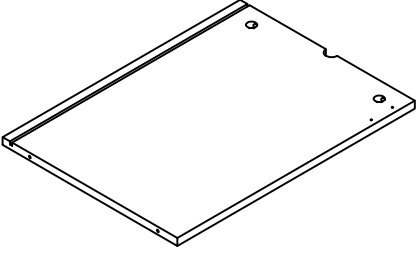
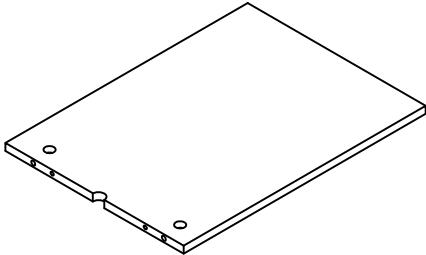
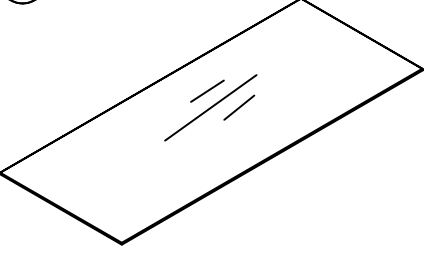
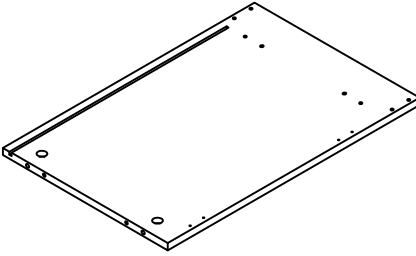
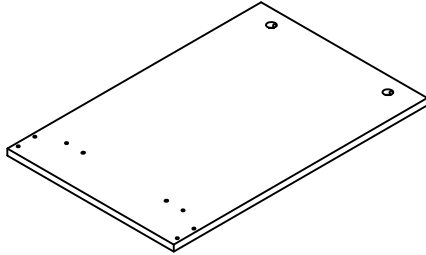
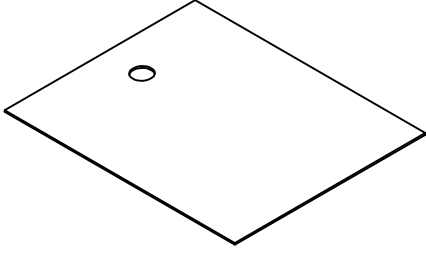
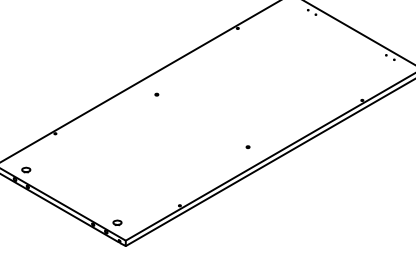
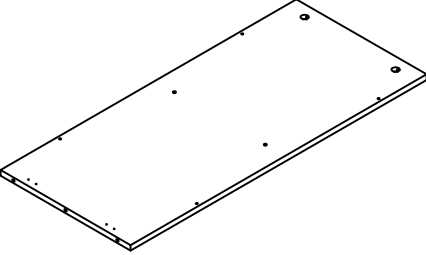
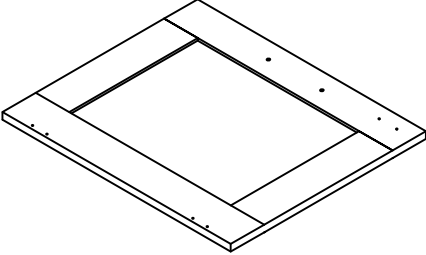
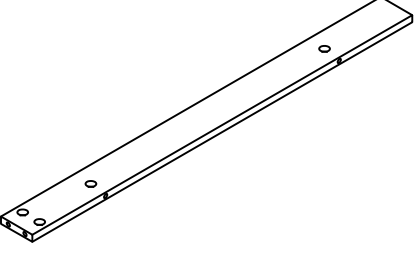
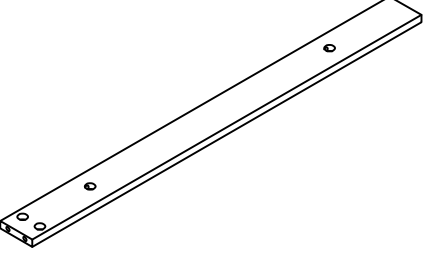
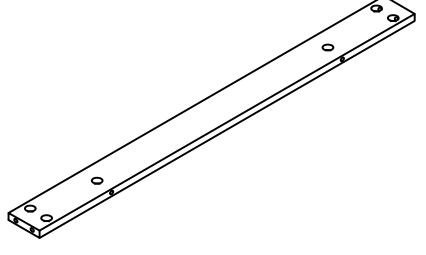

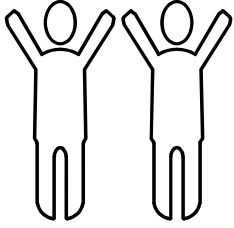

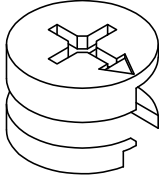
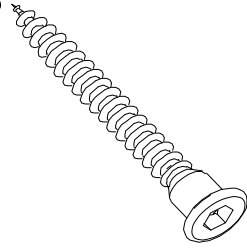
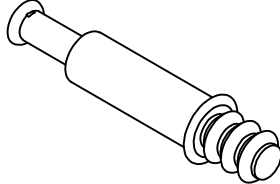
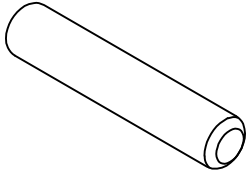
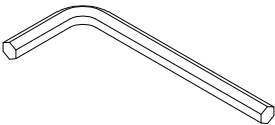
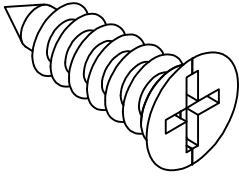
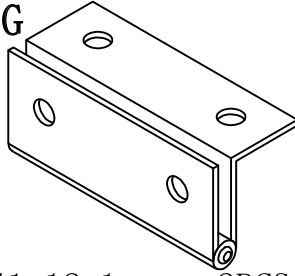
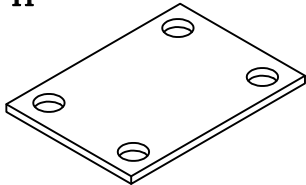
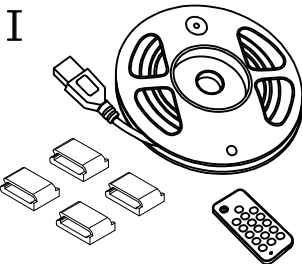
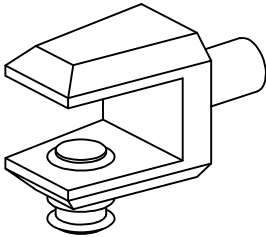
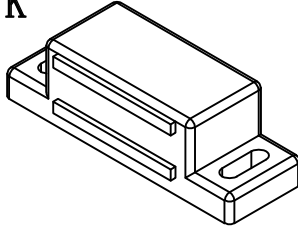
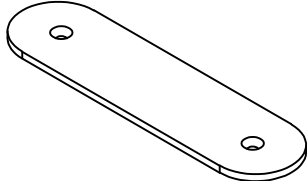
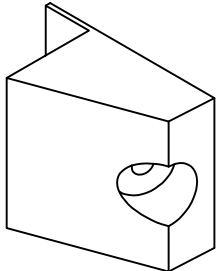
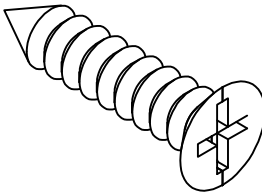
<p>①</p>  <p>1 PC</p>	<p>②</p>  <p>1 PC</p>	<p>③</p>  <p>2 PCS</p>
<p>④</p>  <p>1 PC</p>	<p>⑤</p>  <p>1 PC</p>	<p>⑥</p>  <p>1 PC</p>
<p>⑦</p>  <p>1 PC</p>	<p>⑧</p>  <p>1 PC</p>	<p>⑨</p>  <p>1 PC</p>
<p>⑩</p>  <p>1 PC</p>	<p>⑪</p>  <p>1 PC</p>	<p>⑫</p>  <p>1 PC</p>
<p>⑬</p>  <p>1 PC</p>	<p>⑭</p>  <p>1 PC</p>	<p>⑮</p>  <p>2 PCS</p>

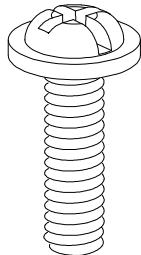
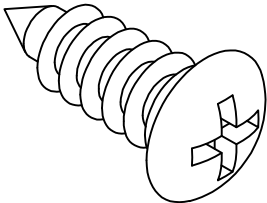
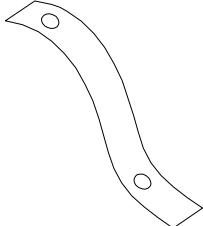
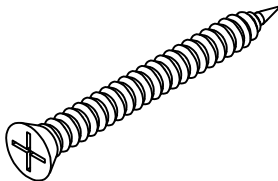
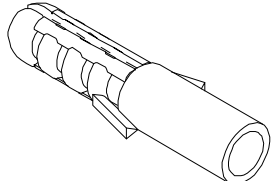

<p><b>A</b></p>  <p>∅15*10mm 44PCS</p>	<p><b>B</b></p>  <p>4PCS</p>	<p><b>C</b></p>  <p>∅6*36mm 44PCS</p>	<p><b>D</b></p>  <p>∅6*30mm 22PCS</p>
<p><b>E</b></p>  <p>1PC</p>	<p><b>F</b></p>  <p>M3*12mm 27PCS</p>	<p><b>G</b></p>  <p>41*12*1mm 2PCS</p>	<p><b>H</b></p>  <p>40*28*1mm 4PCS</p>
<p><b>I</b></p>  <p>1PC</p>	<p><b>J</b></p>  <p>24*12*14mm 4PCS</p>	<p><b>K</b></p>  <p>46*14*16mm 1PC</p>	<p><b>L</b></p>  <p>44*12*1mm 1PC</p>
<p><b>M</b></p>  <p>13*13*11mm 6PCS</p>	<p><b>N</b></p>  <p>M3*16mm 6PCS</p>	<p><b>O</b></p>  <p>104*20*11mm 1PC</p>	<p><b>P</b></p>  <p>M4*16mm 2PCS</p>
<p><b>Q</b></p>  <p>M3*14mm 2PCS</p>	<p><b>R</b></p>  <p>25*205mm 1PC</p>	<p><b>S</b></p>  <p>M4*35mm 1PC</p>	<p><b>T</b></p>  <p>8*38mm 1PC</p>

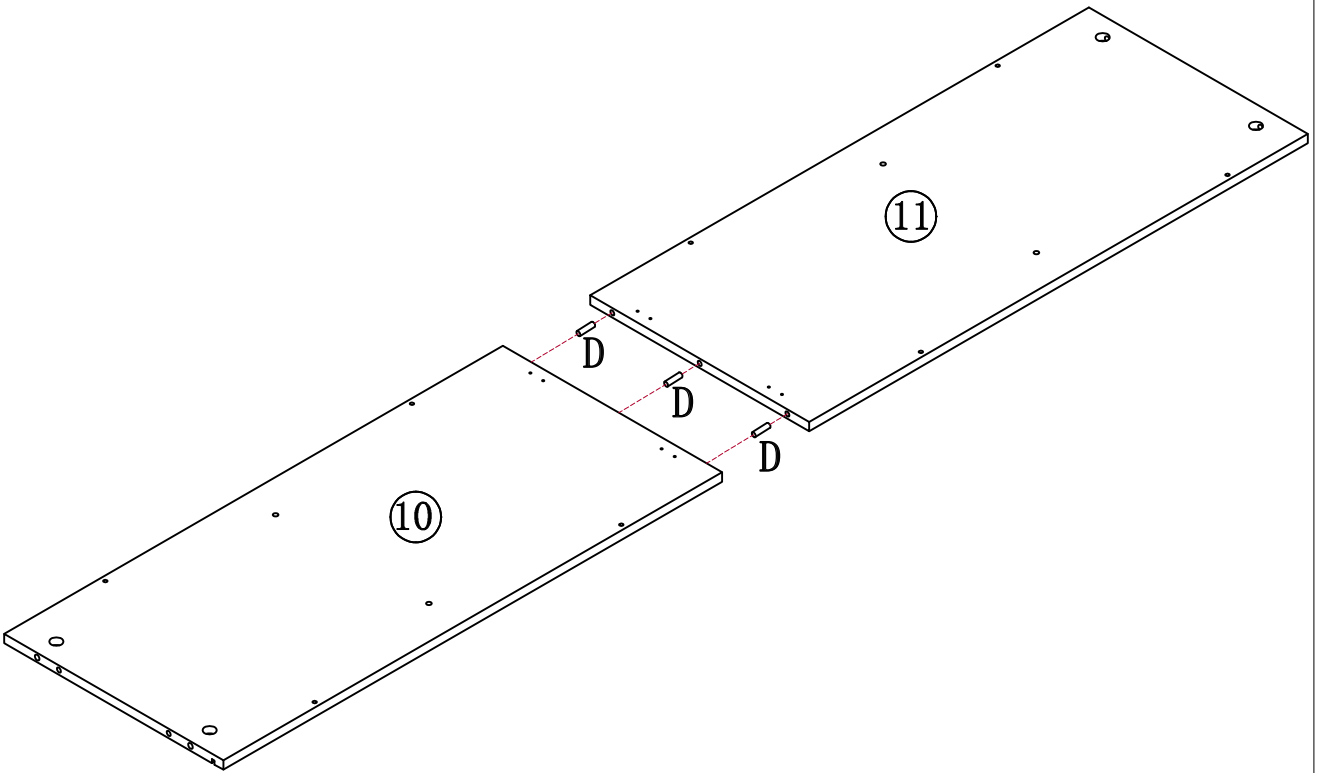

STEP1

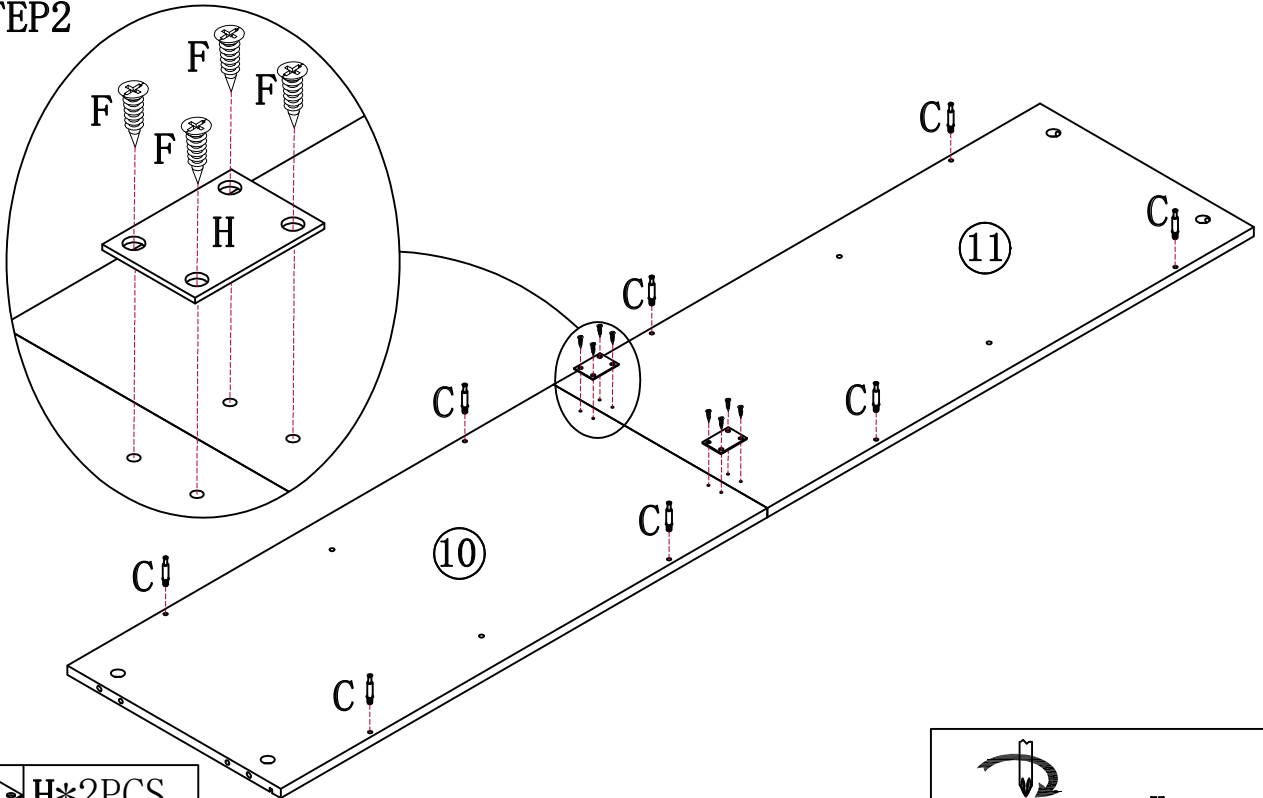

	D*3PCS
---	--------

STEP2



	H*2PCS
	C*8PCS
	F*8PCS

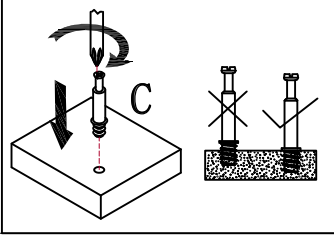

STEP3

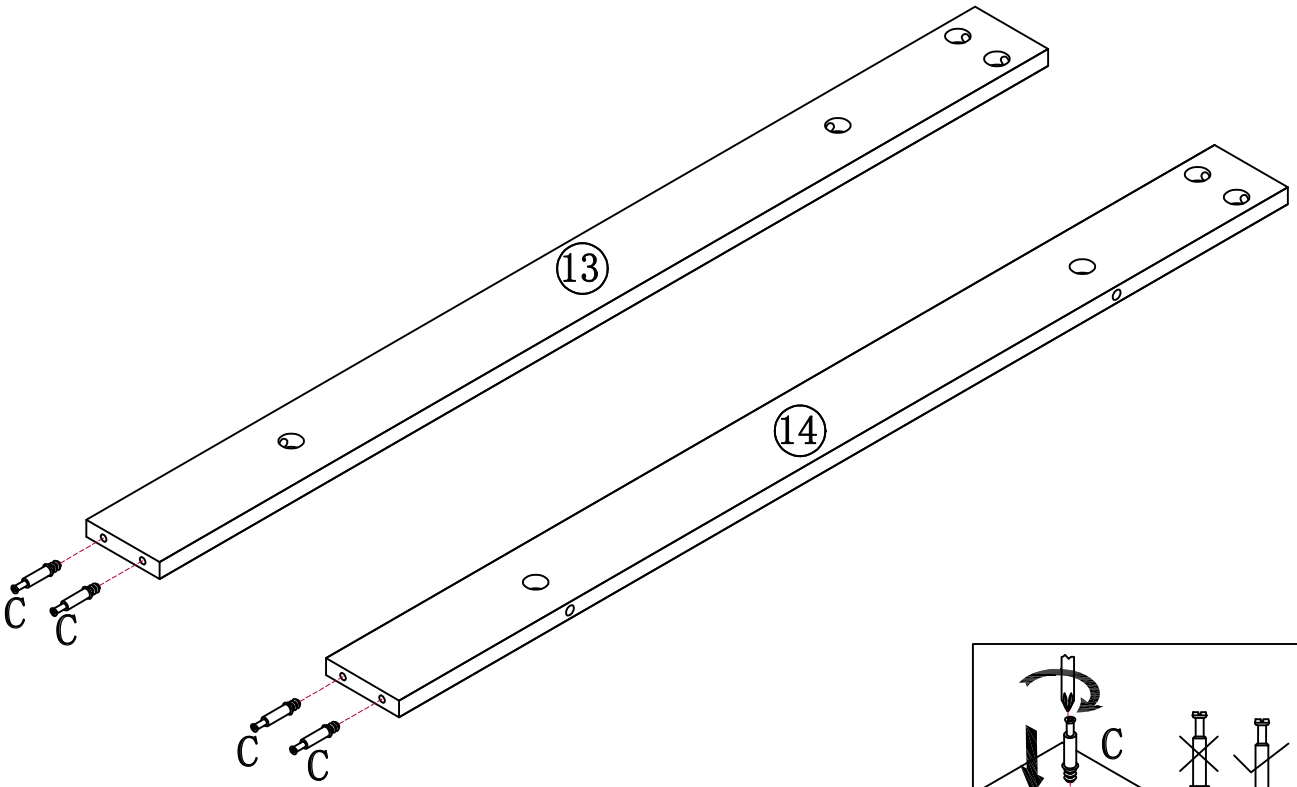

 C\*4PCS

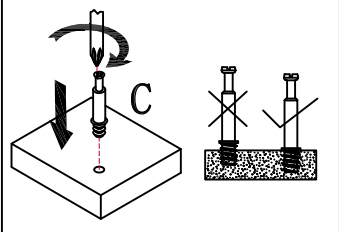

STEP4

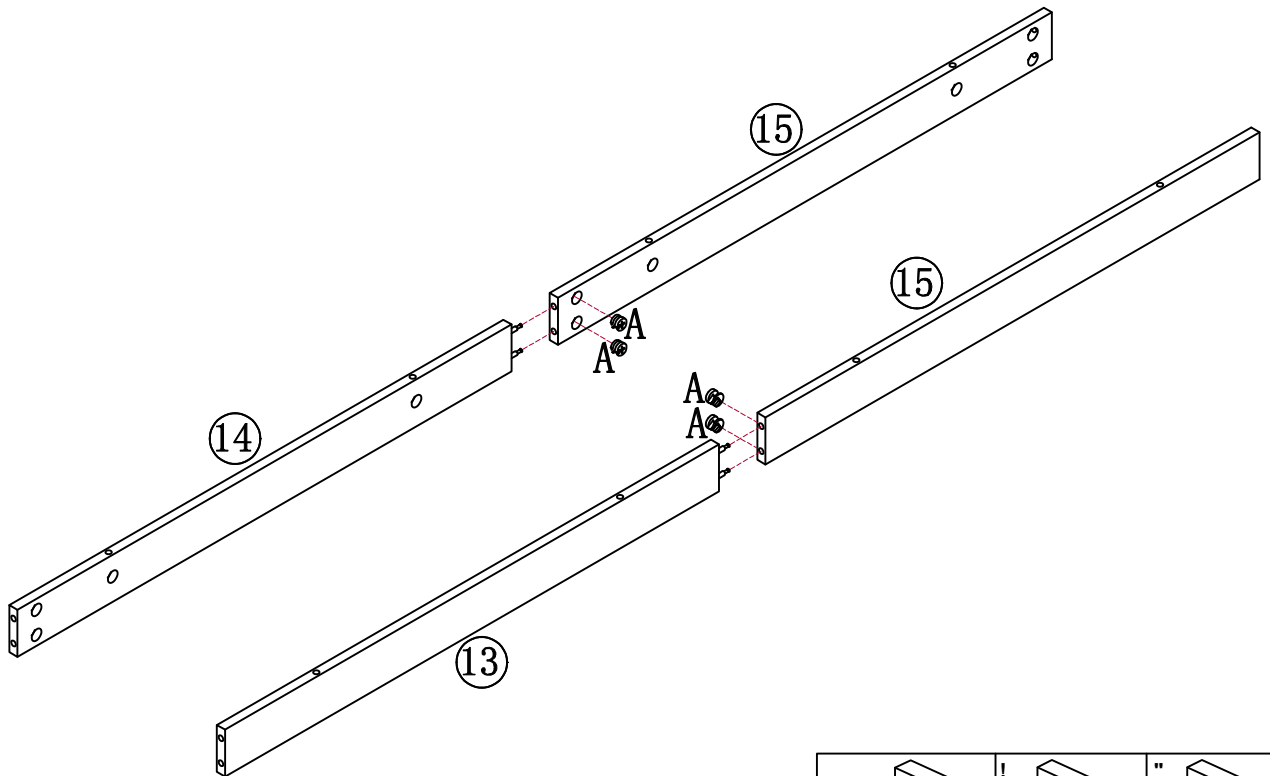

 A\*4PCS

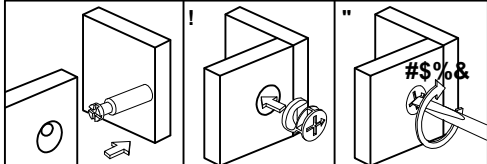

STEP5

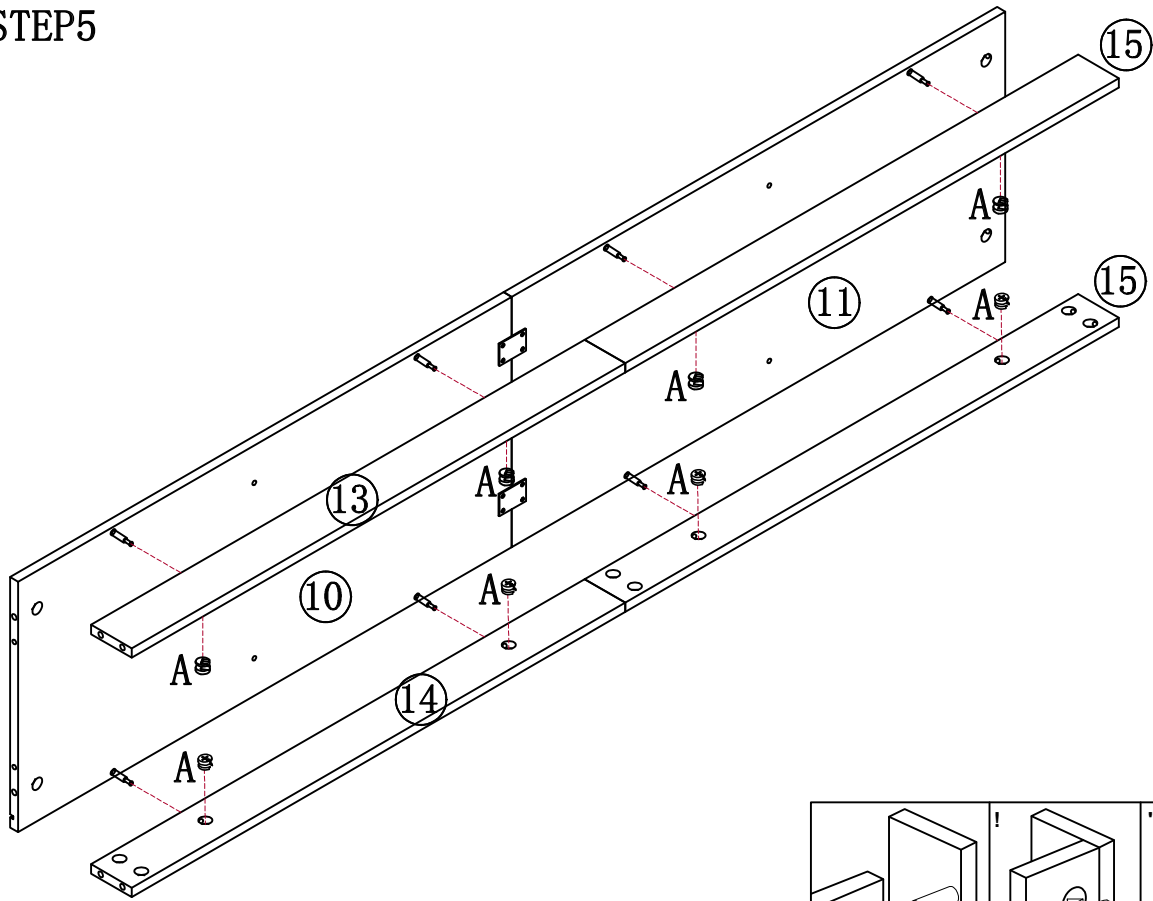

A\*8PCS

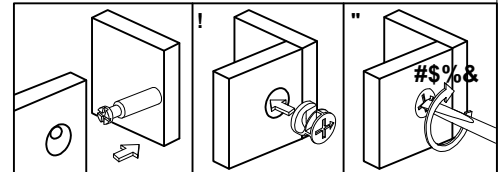

STEP6

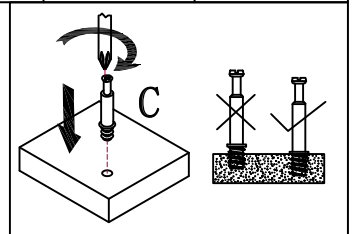
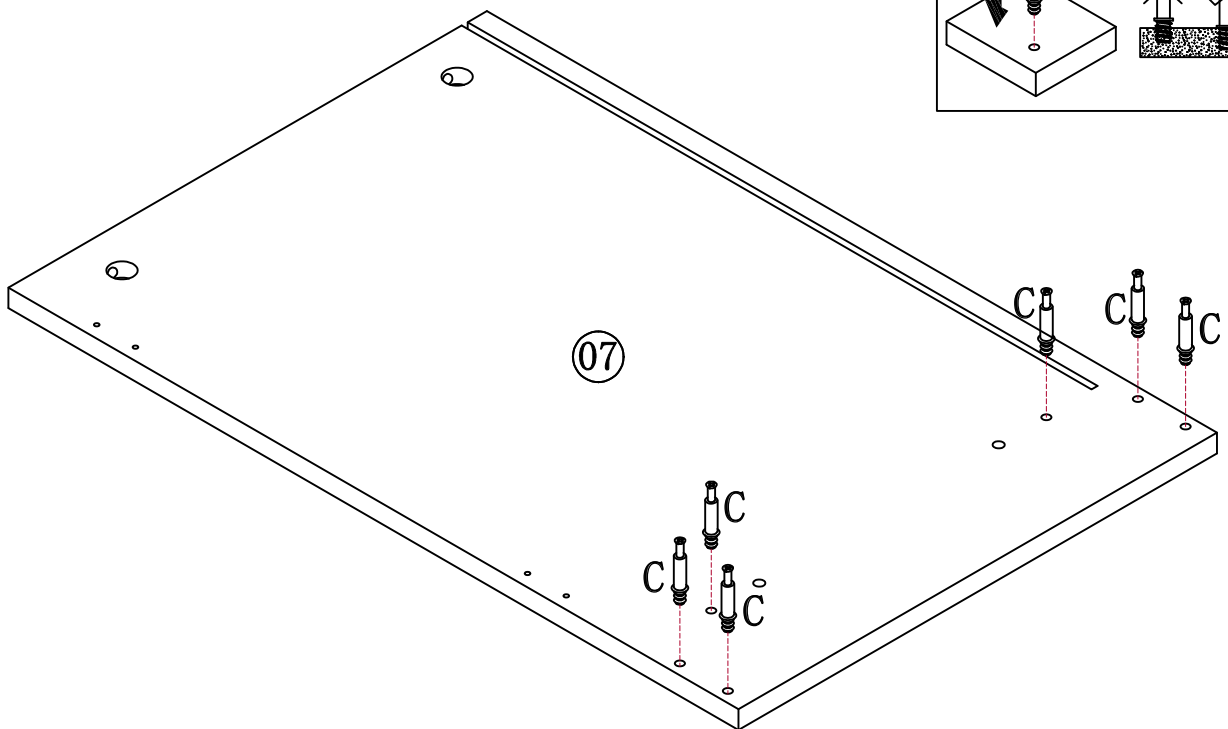

C\*6PCS

STEP7

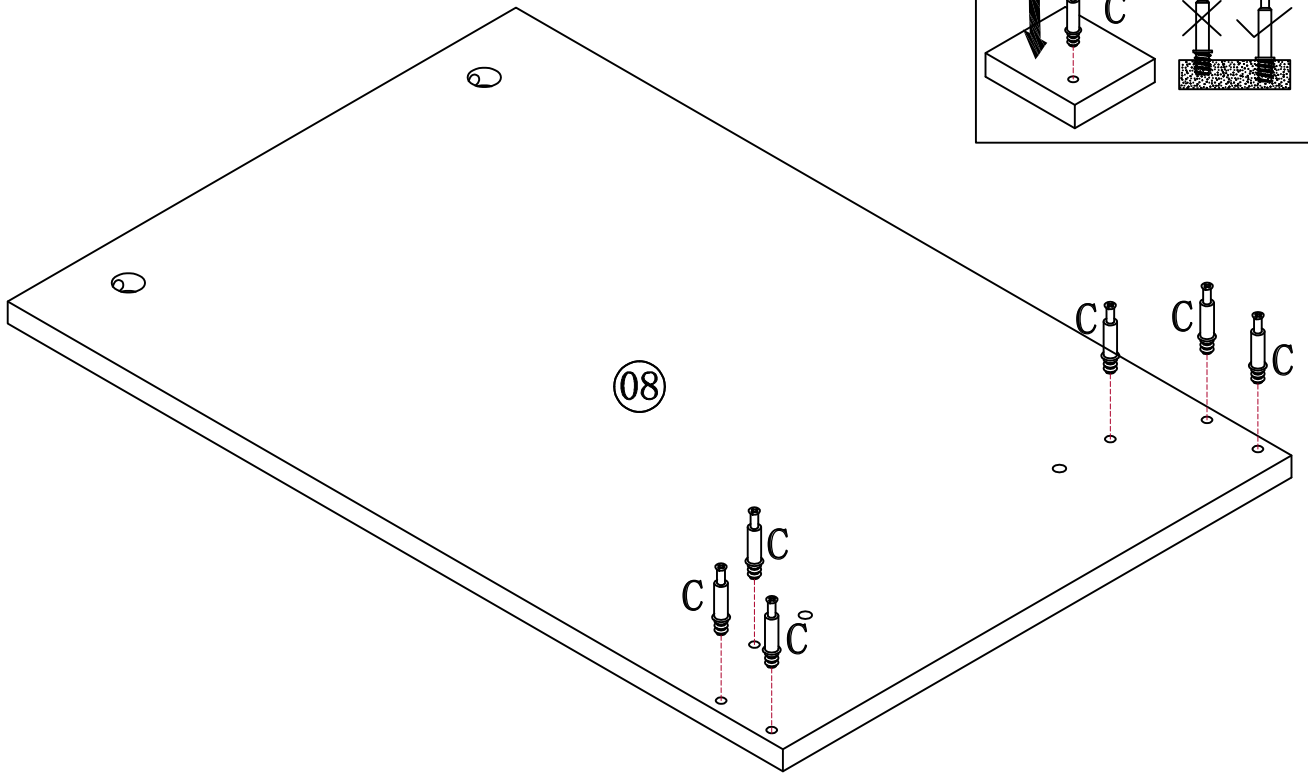

C\*6PCS

STEP8

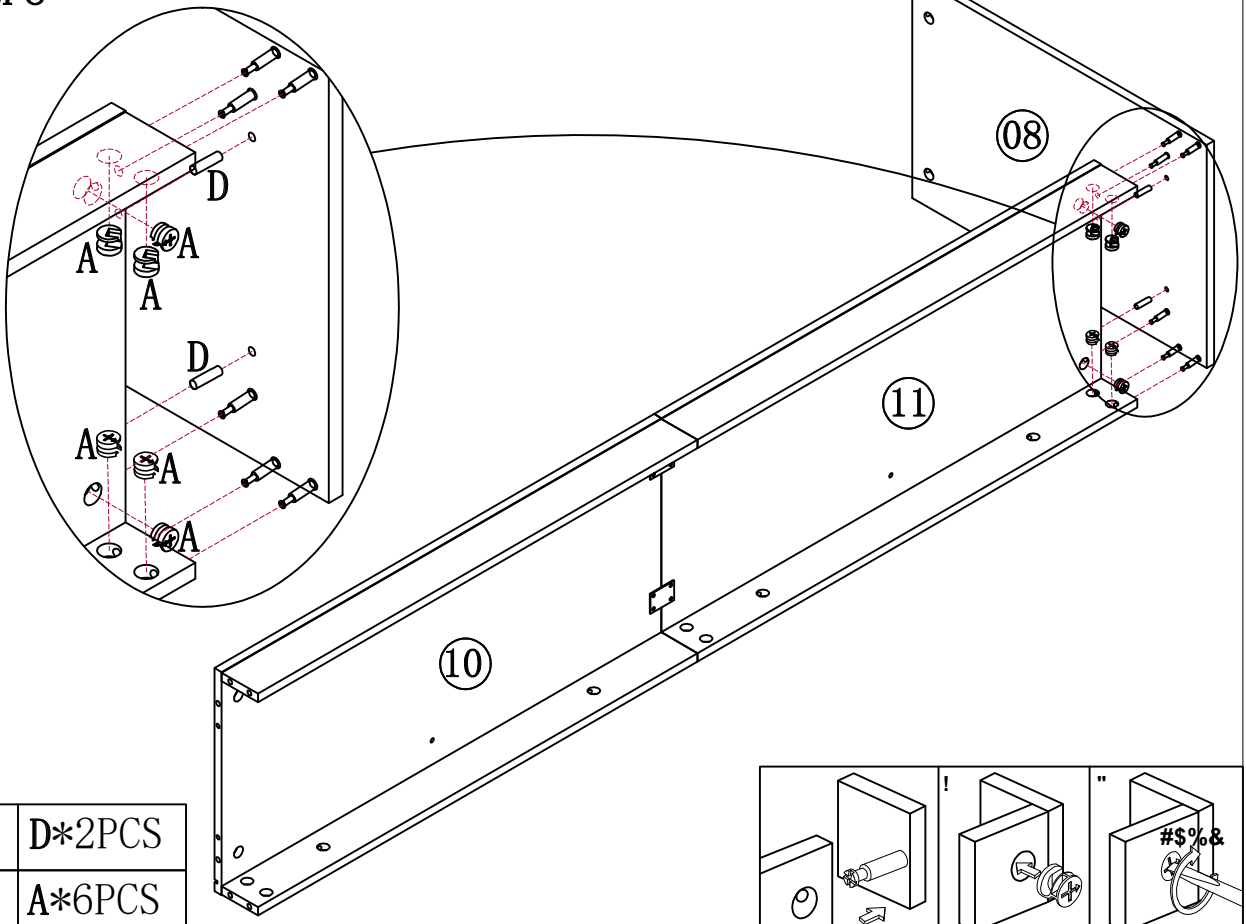



D\*2PCS

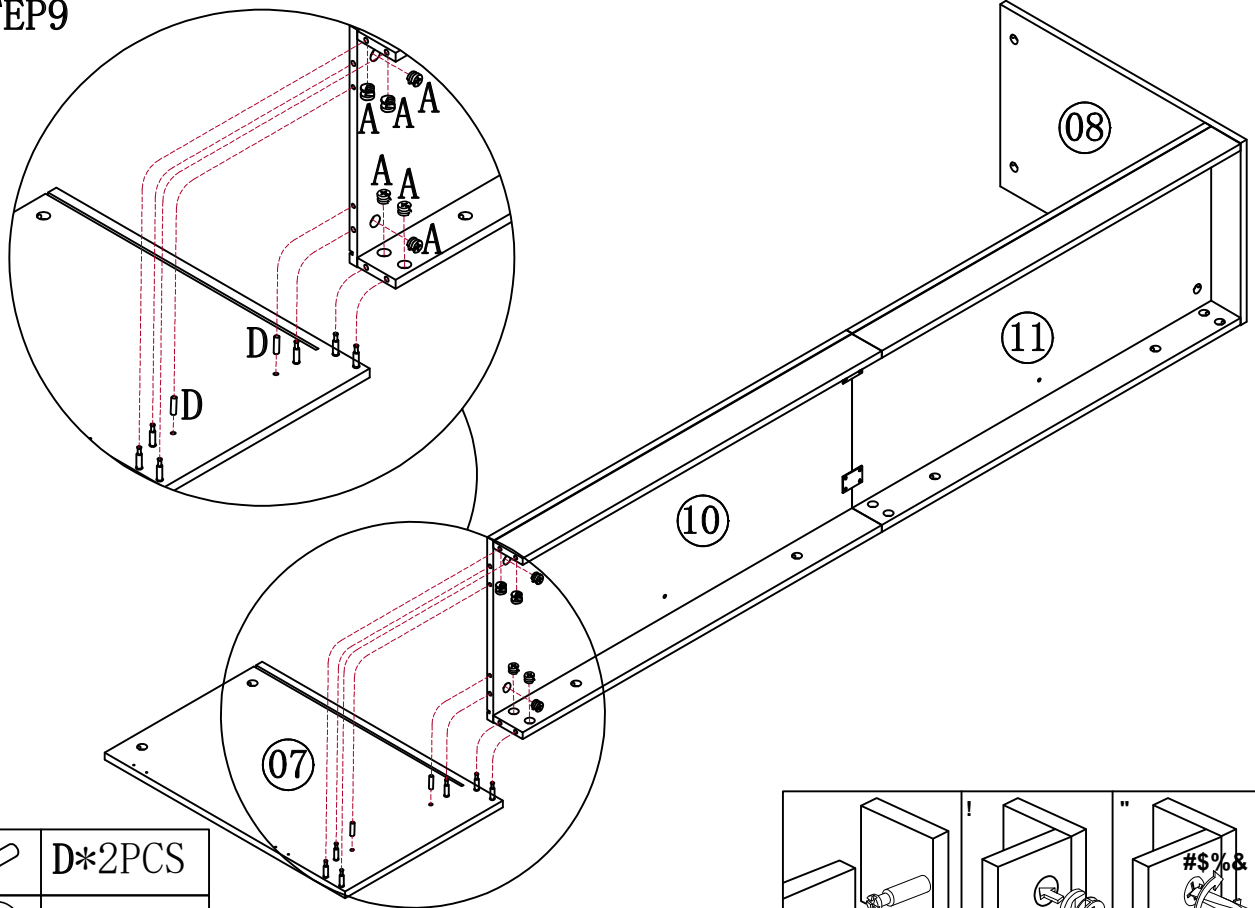

A\*6PCS

STEP9



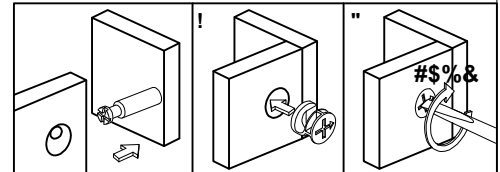

	D*2PCS
	A*6PCS

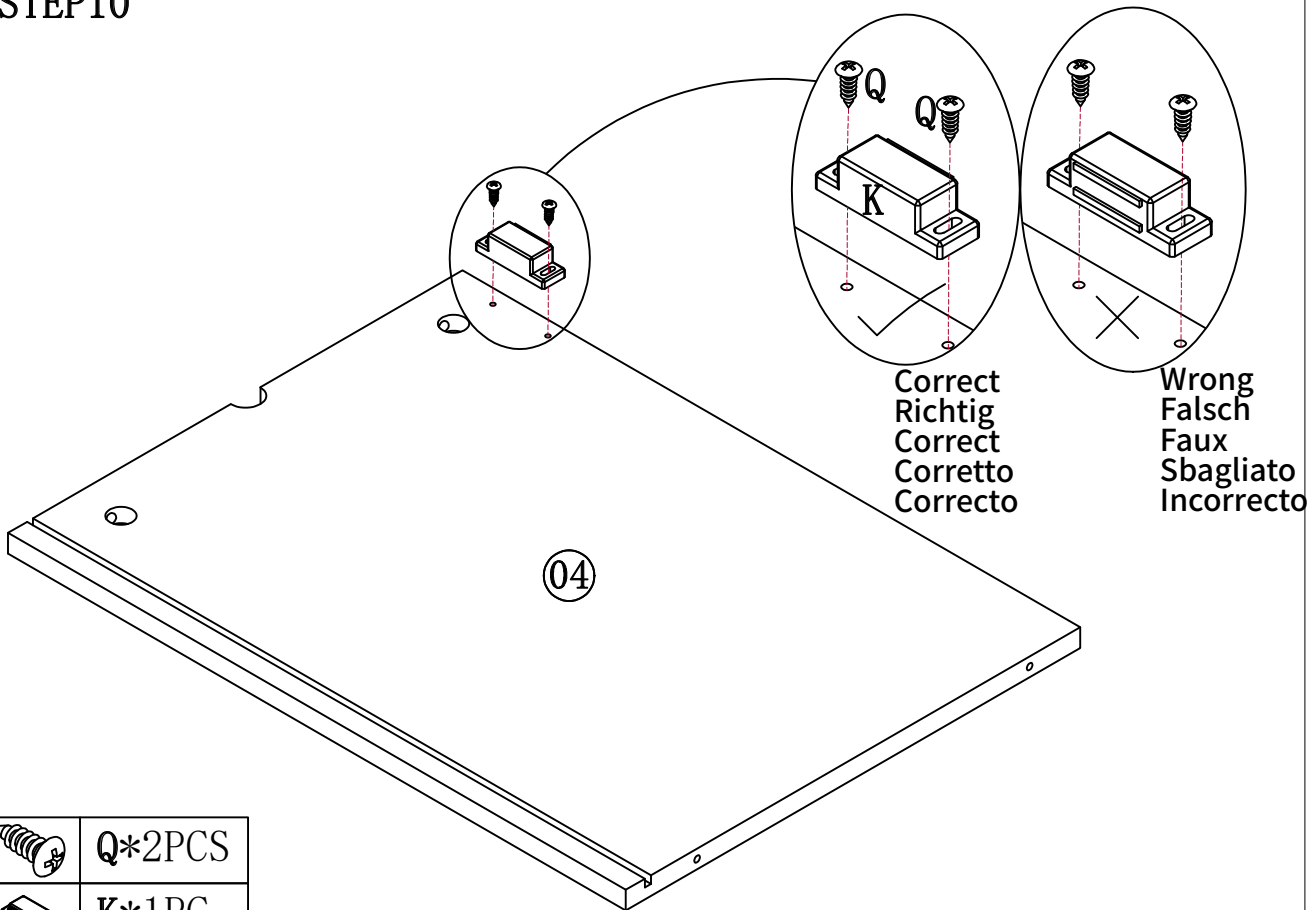

STEP10



	Q*2PCS
	K*1PC

STEP11

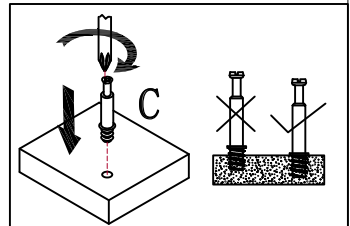
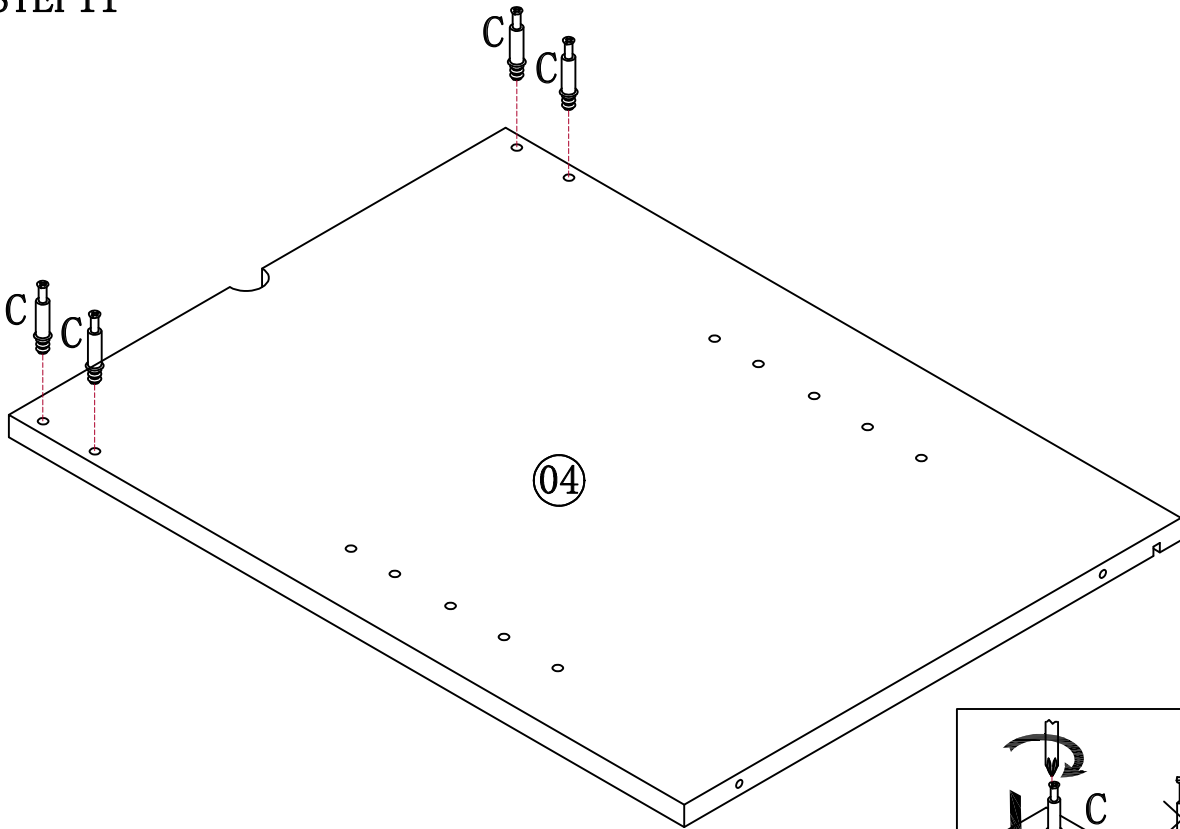

C\*4PCS

STEP12

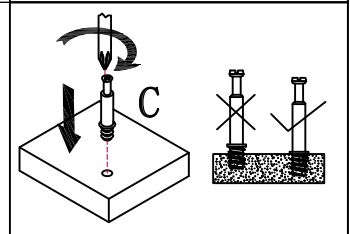
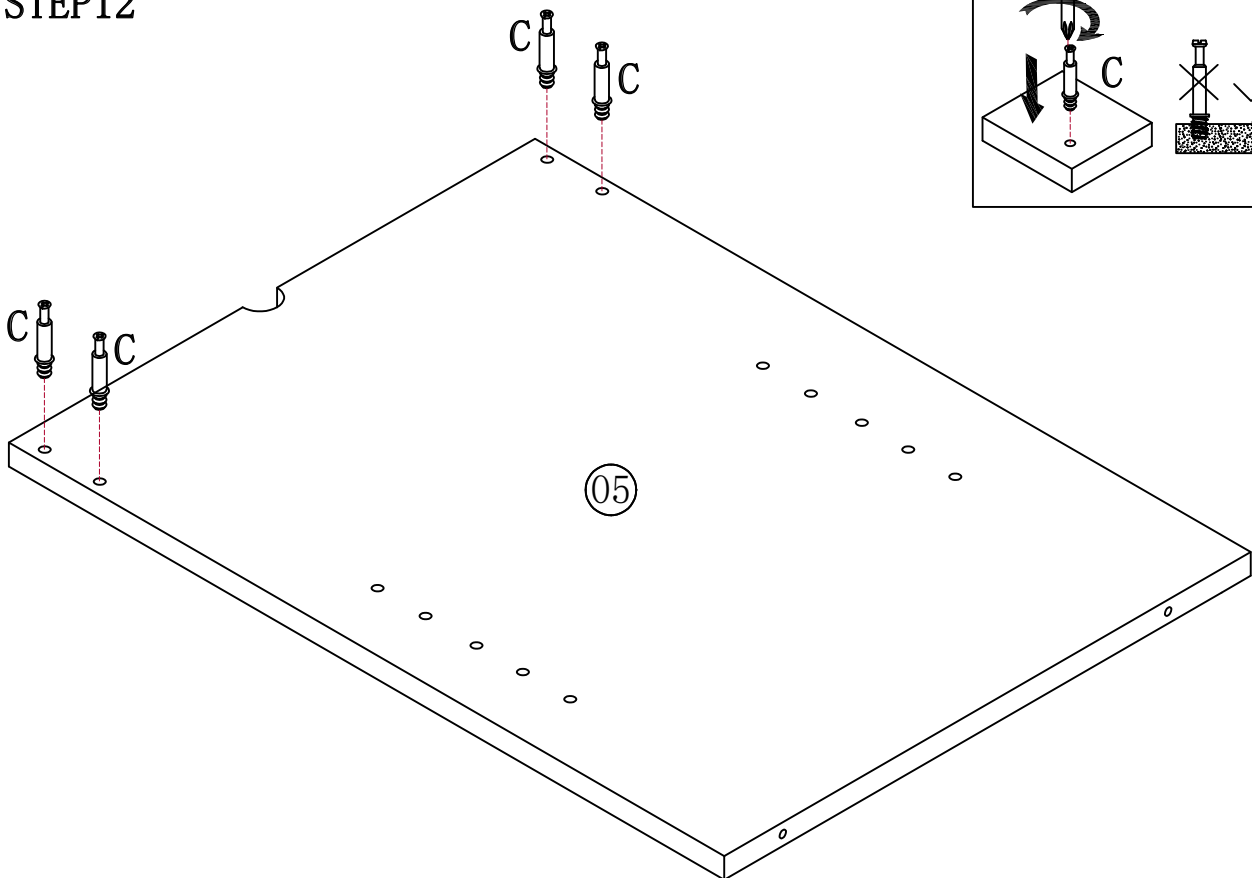

C\*4PCS

# STEP13

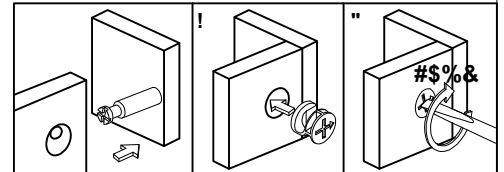
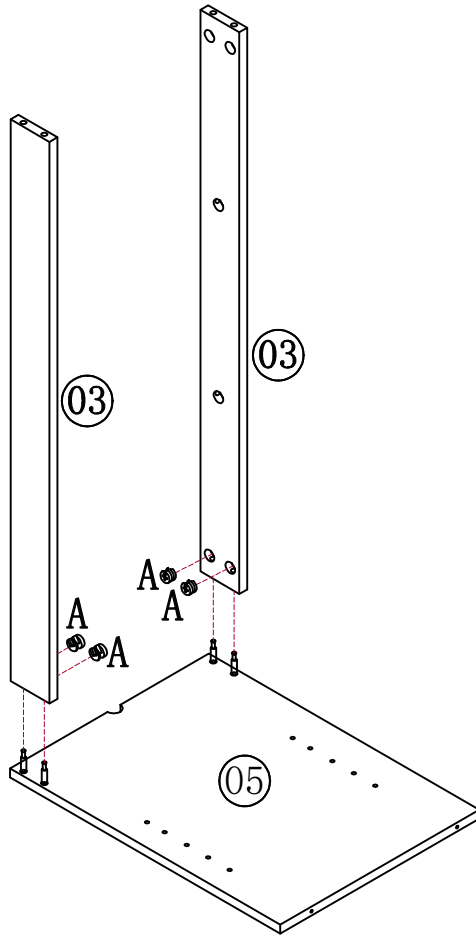

A\*4PCS

# STEP14

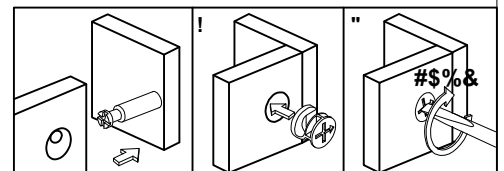
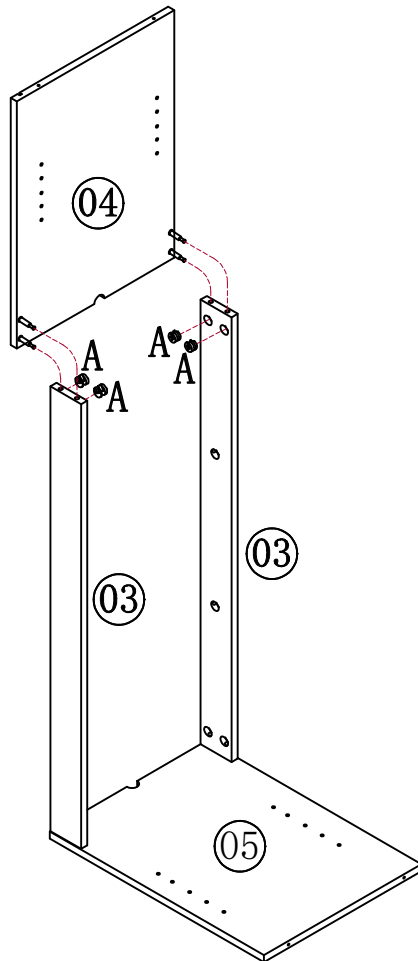

A\*4PCS

STEP15

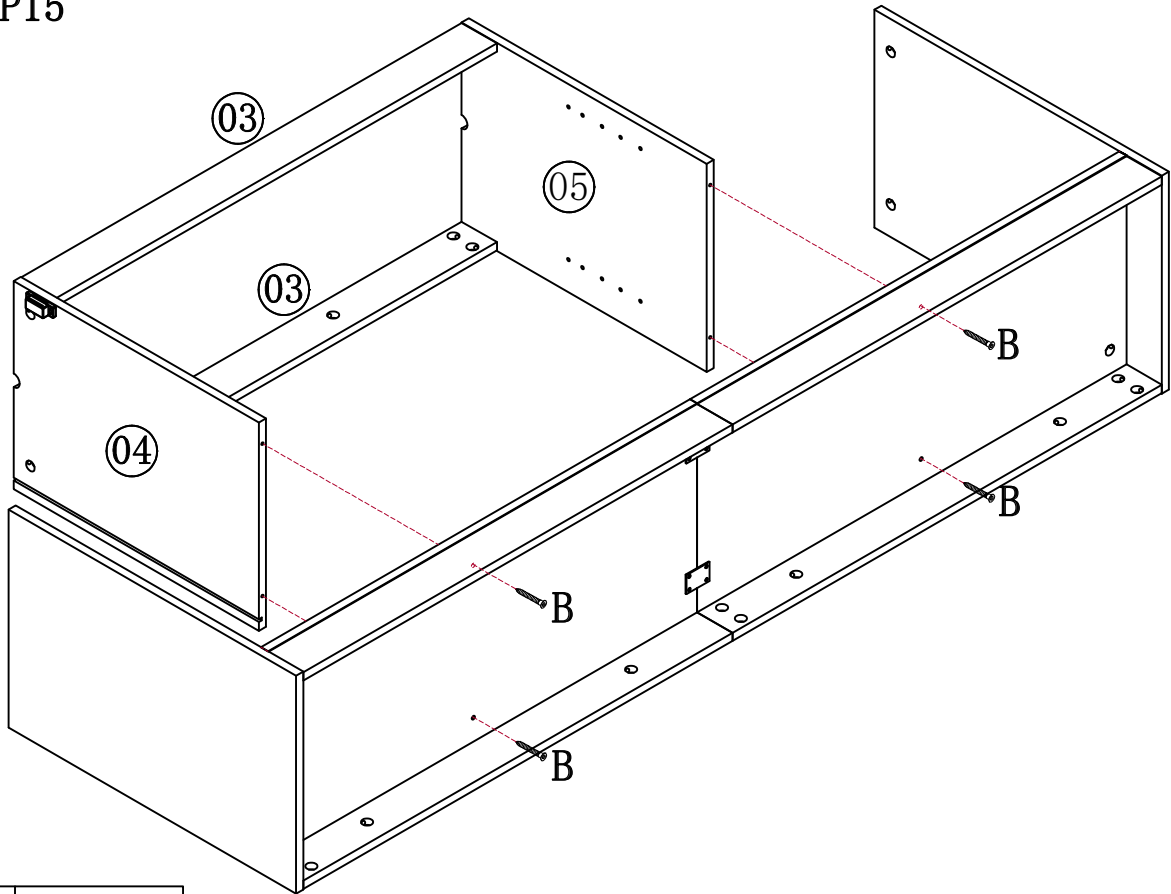

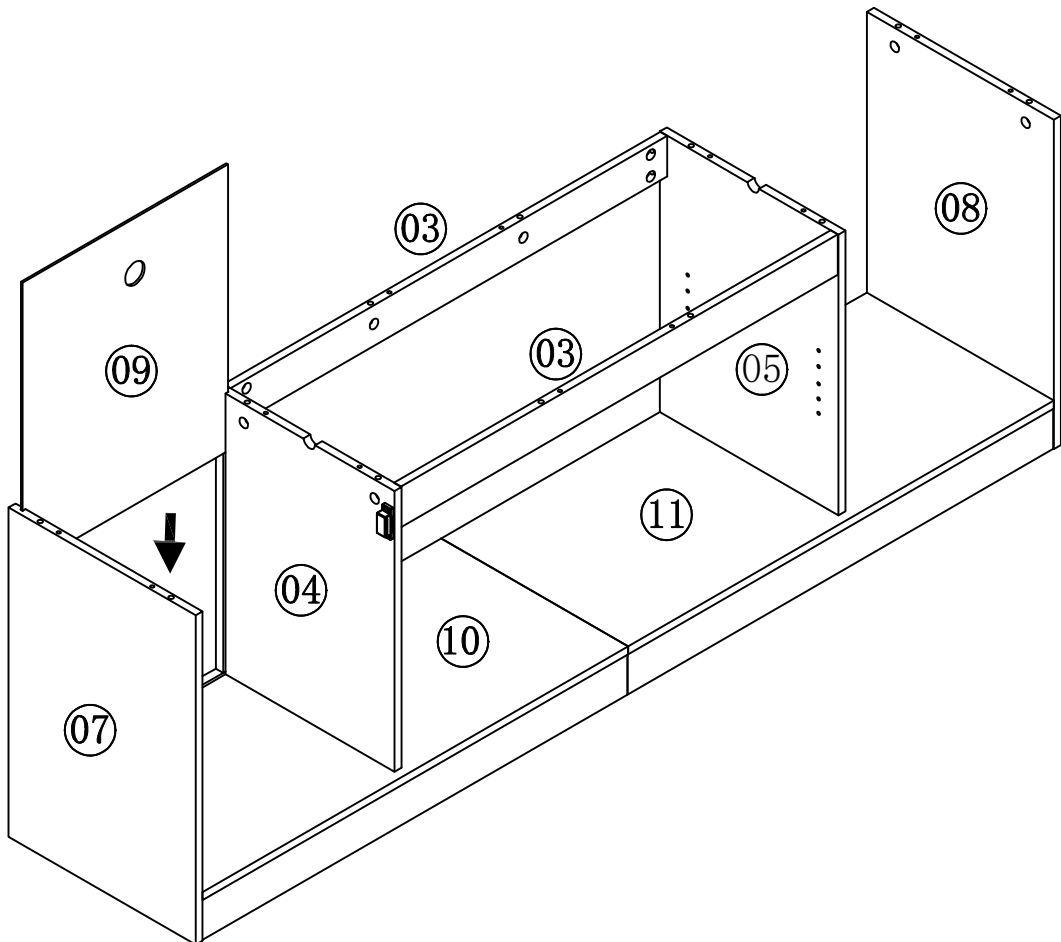

B\*4PCS

STEP16



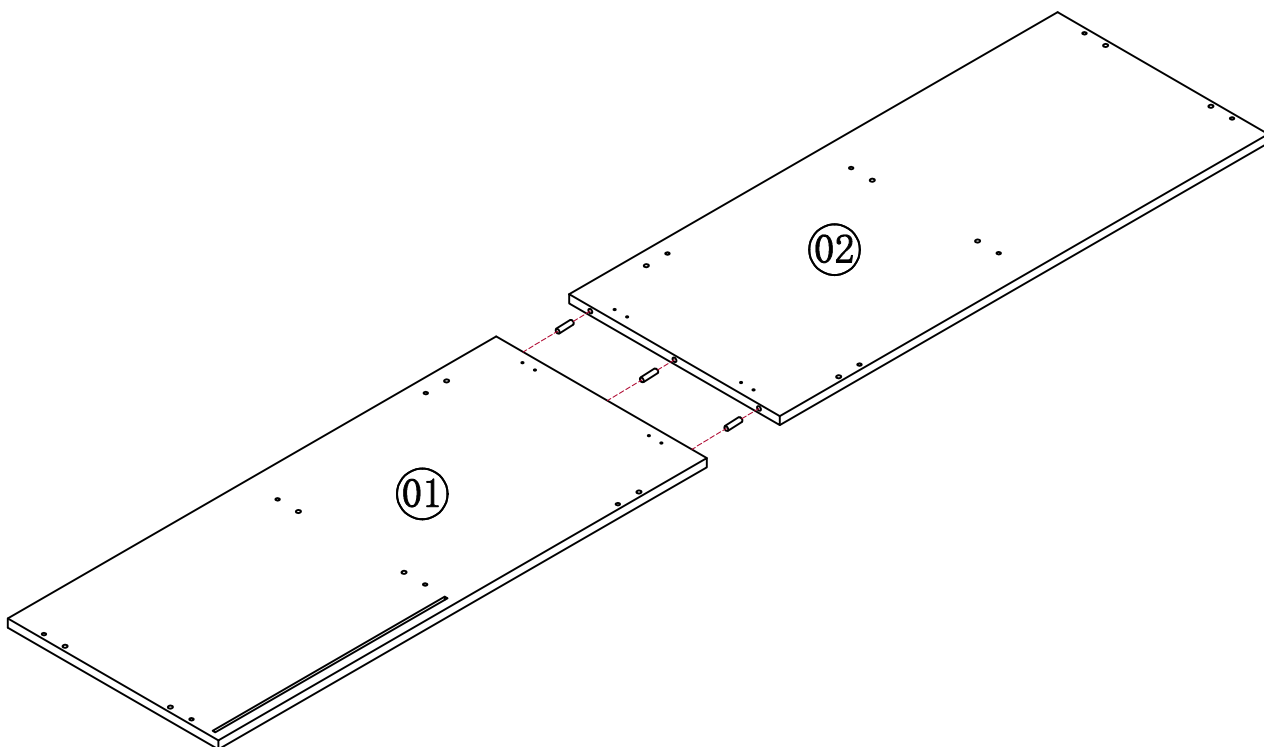

# STEP17

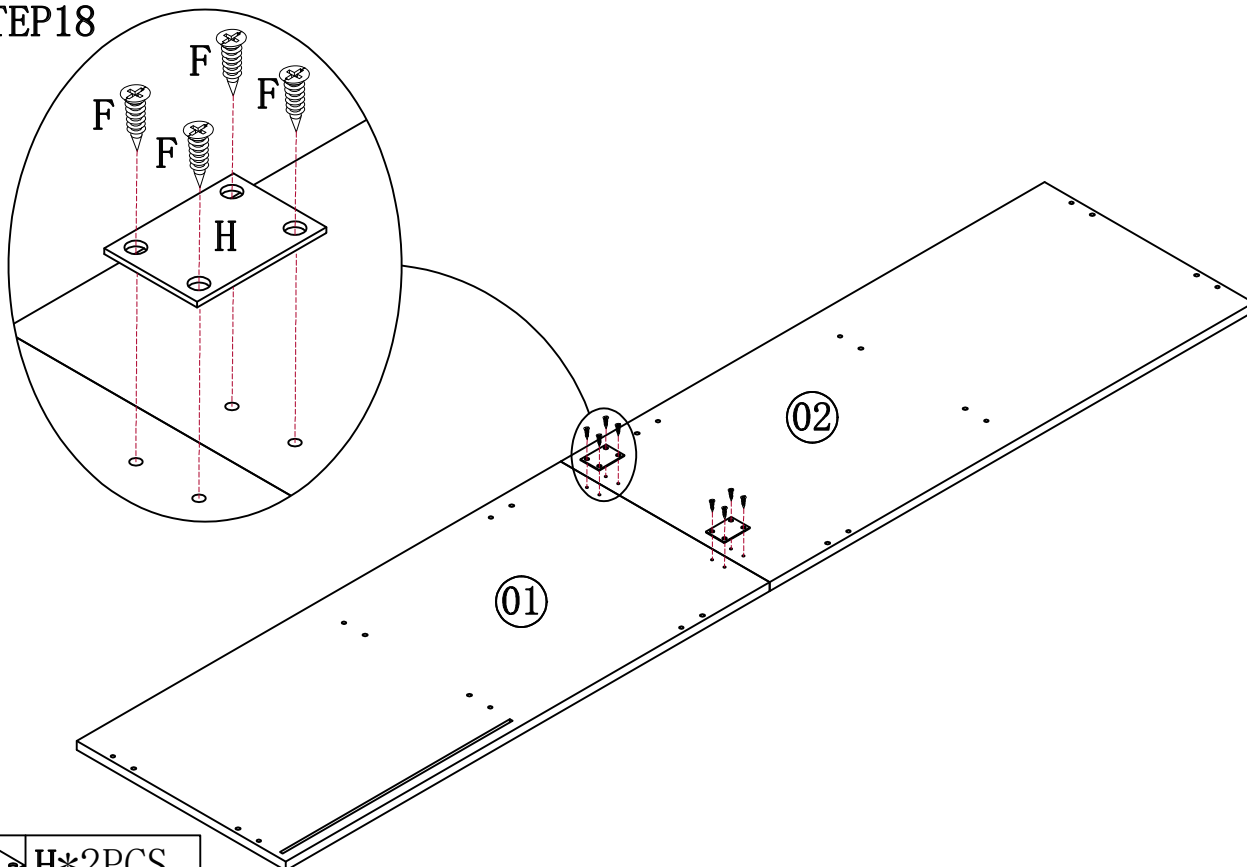

 D\*3PCS

# STEP18



 H\*2PCS  
 F\*8PCS

# STEP19

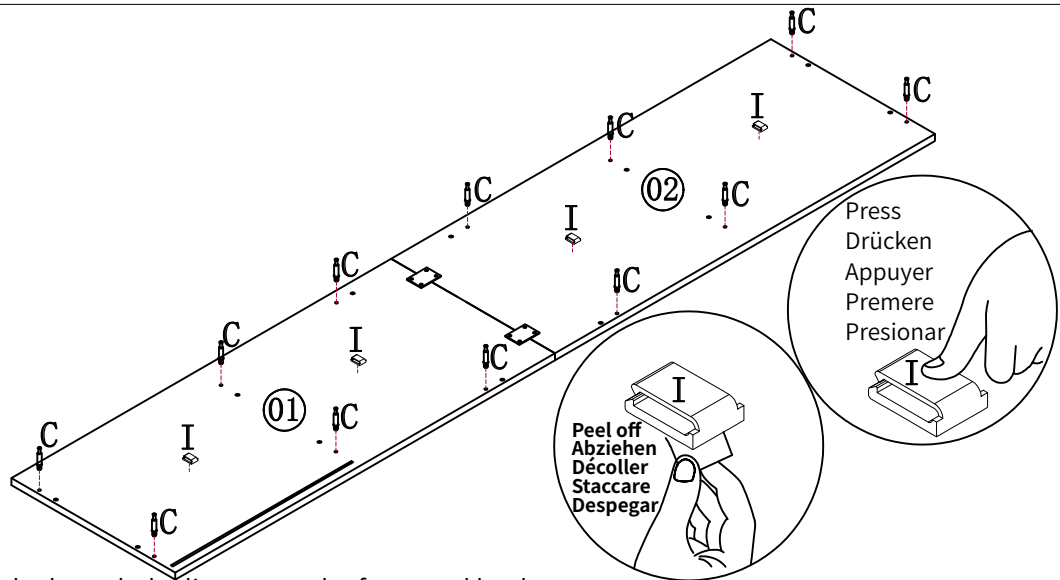



When attaching the lamp belt clip, center the front and back.

Beim Anbringen des Lampenclips den Vorder- und Rückteil zentrieren.

Lors de la fixation du clip de ceinture de la lampe, centrez l'avant et l'arrière.

Quando si fissa la clip della lampada, centrare la parte anteriore e posteriore.

Al colocar el clip de cinturón de la lámpara, centre el frente y la parte trasera.

	C*12PCS
	I*1PC

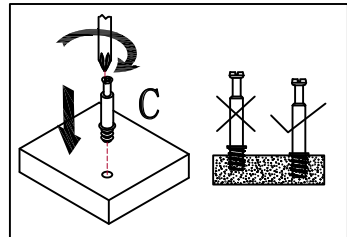

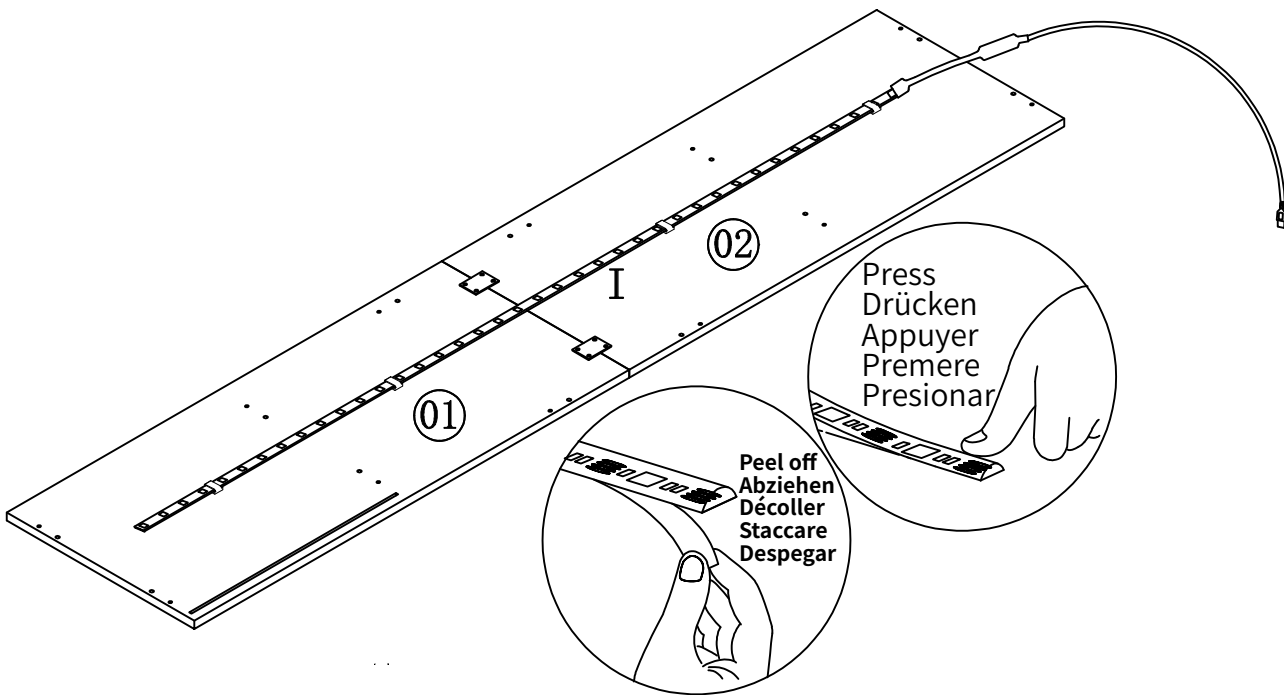

# STEP20

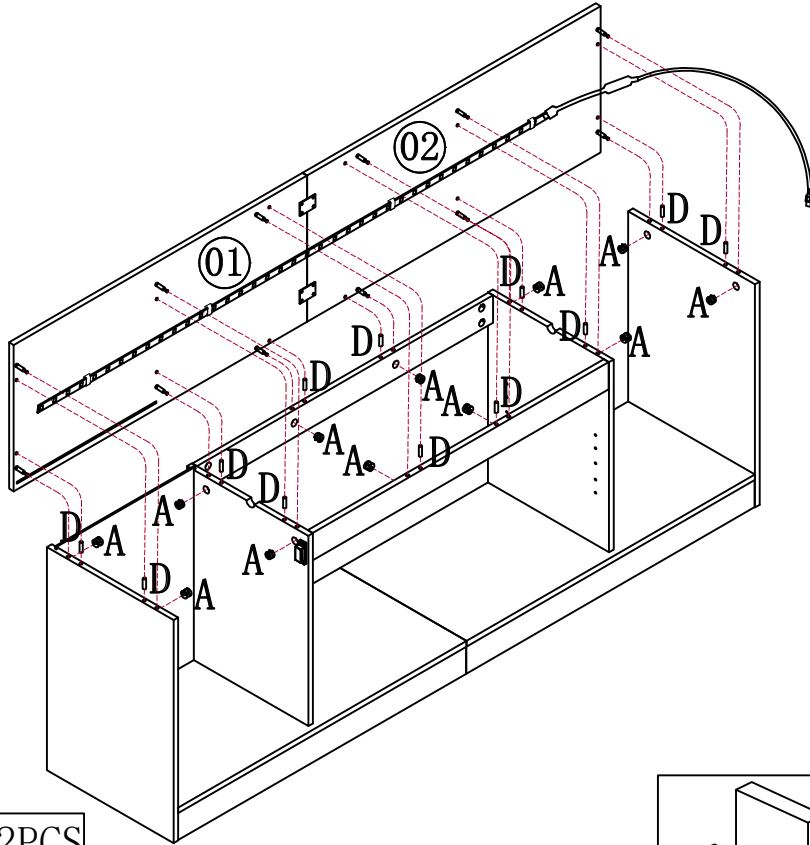

	I*1PC
---	-------

STEP21





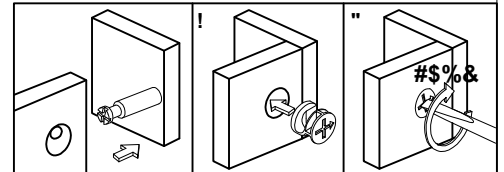

	D*12PCS
	A*12PCS

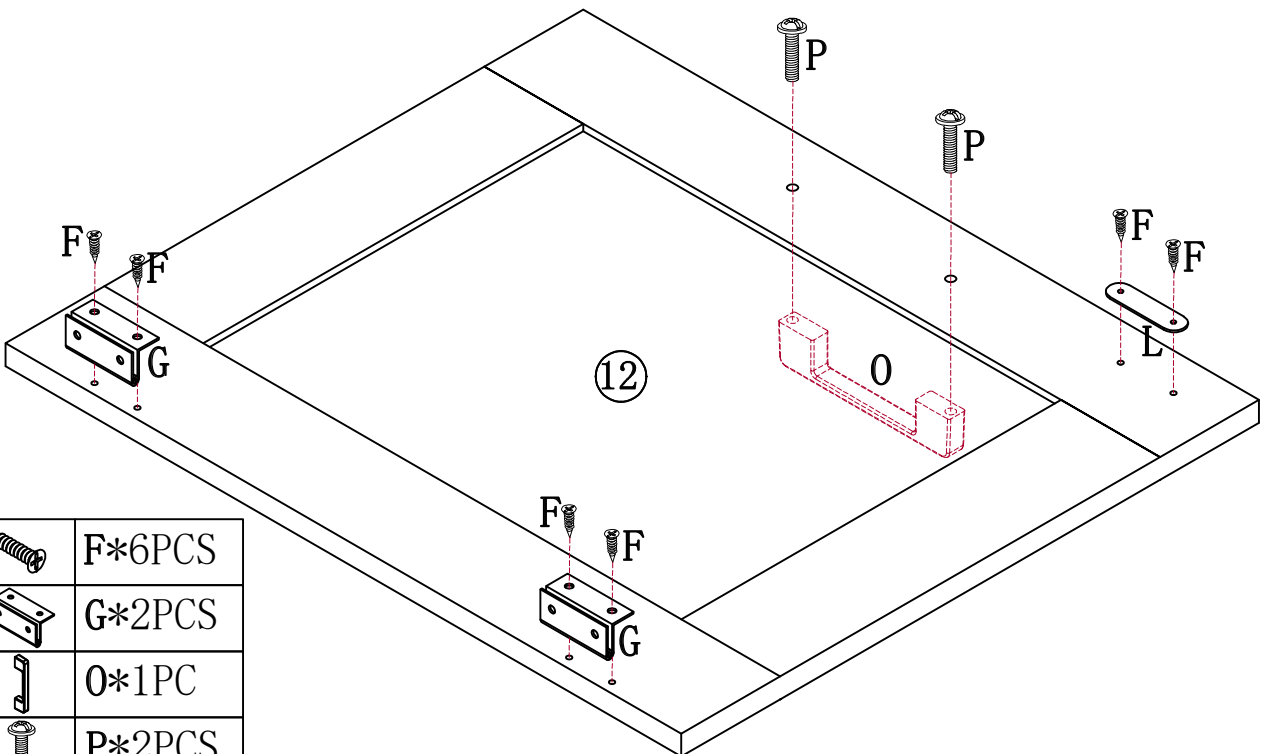

STEP22



	F*6PCS
	G*2PCS
	O*1PC
	P*2PCS
	L*1PC

STEP23

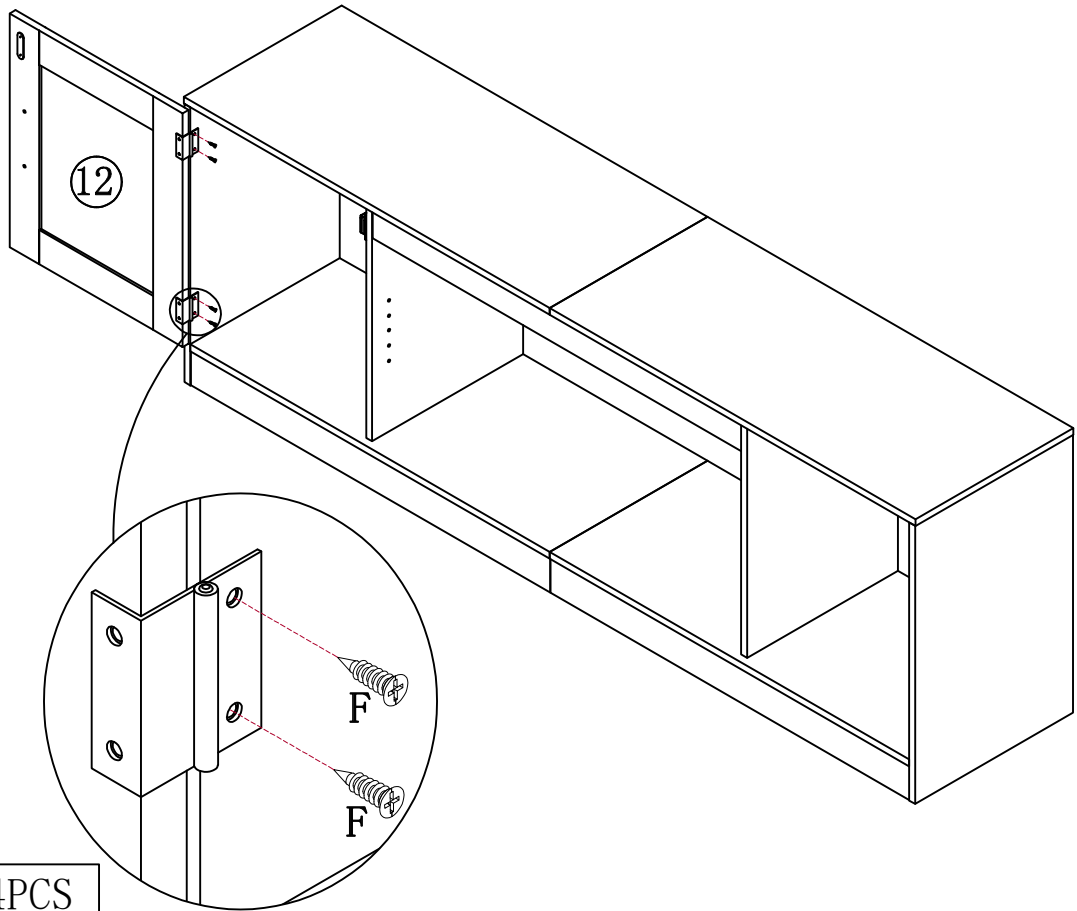

F\*4PCS

STEP24

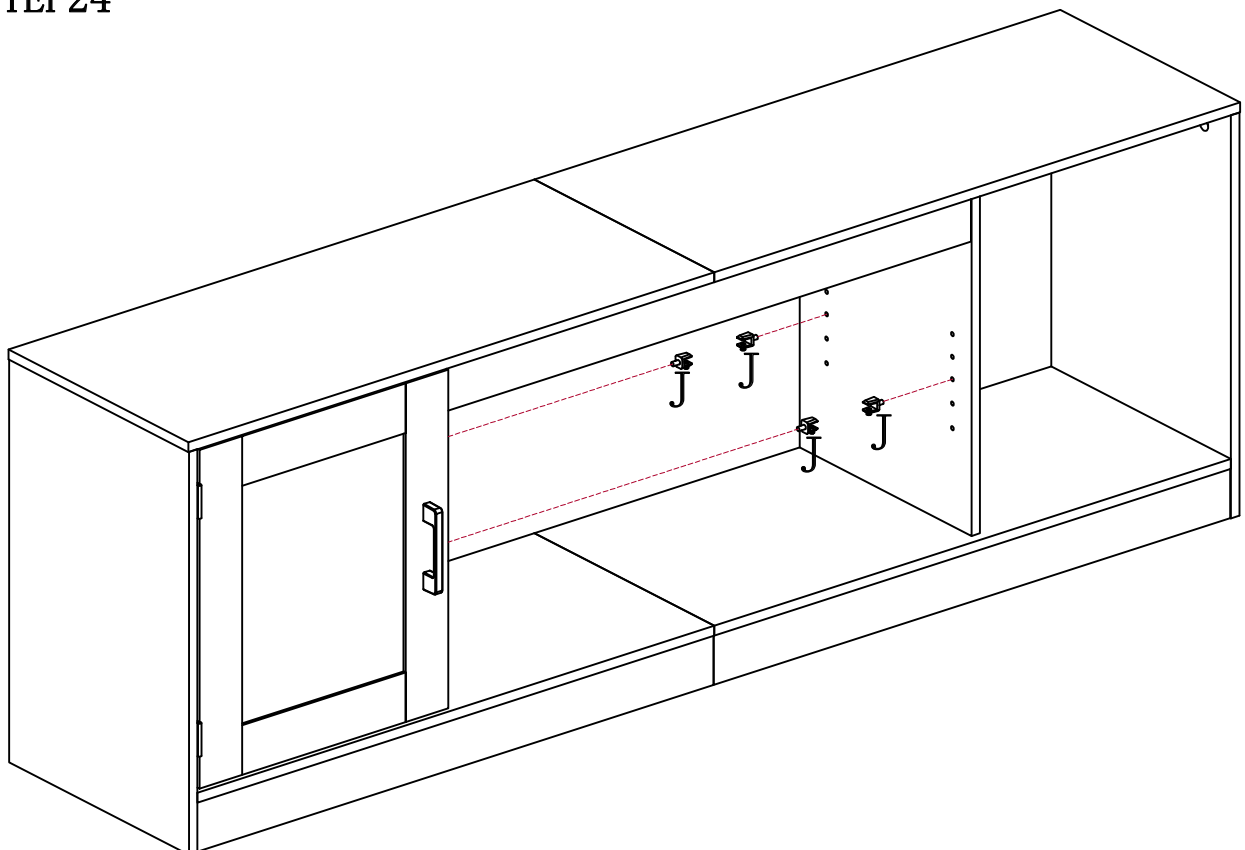

J\*4PCS

STEP25

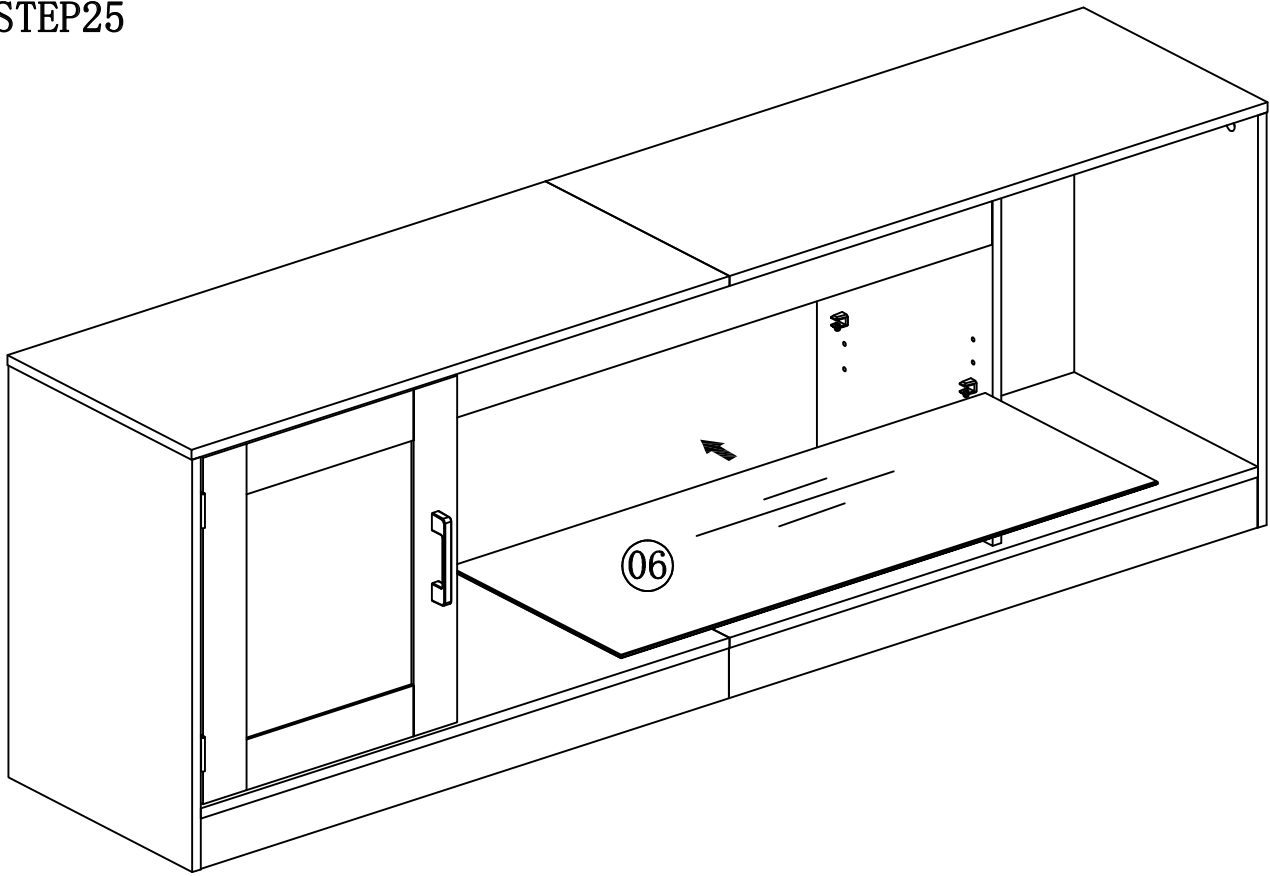



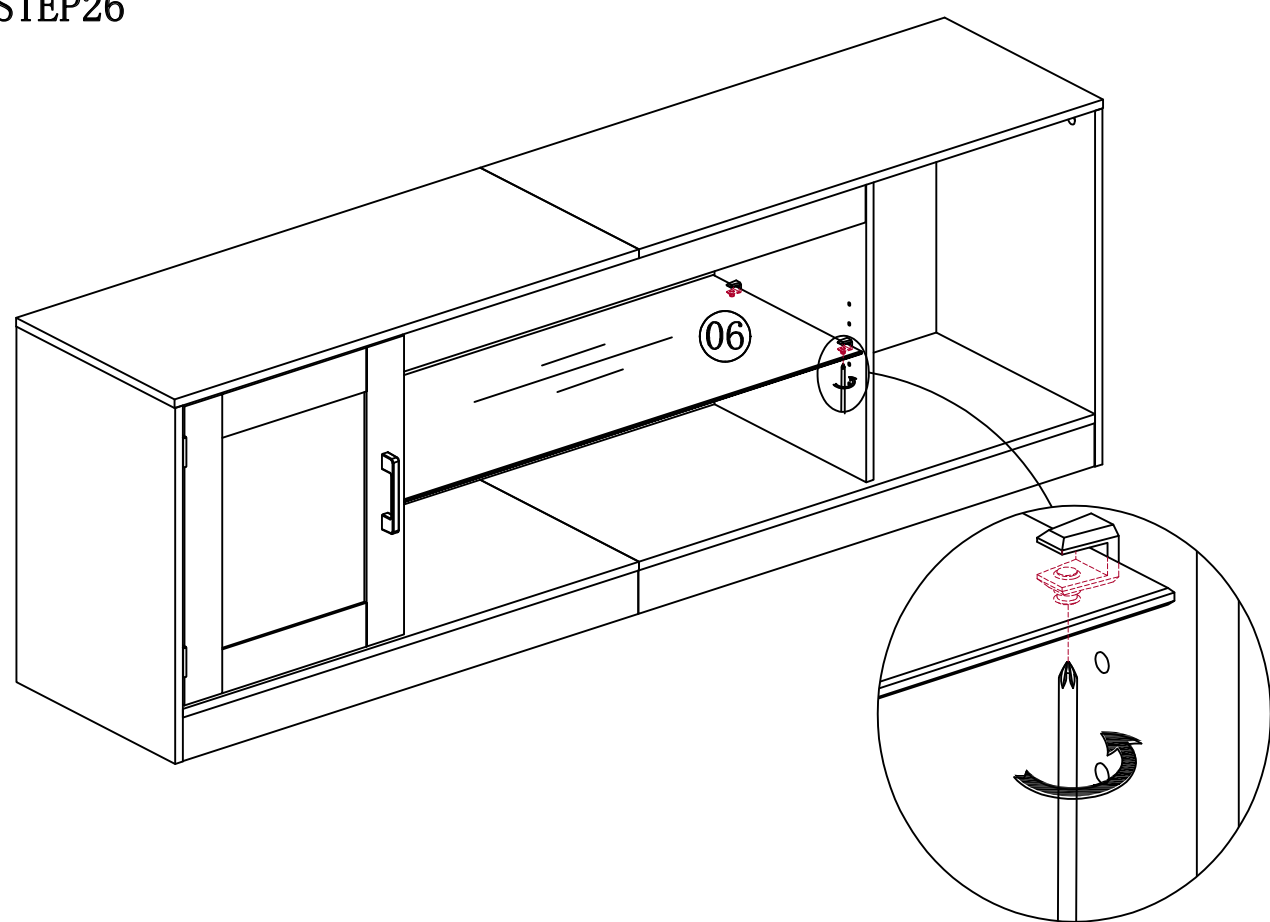

STEP26

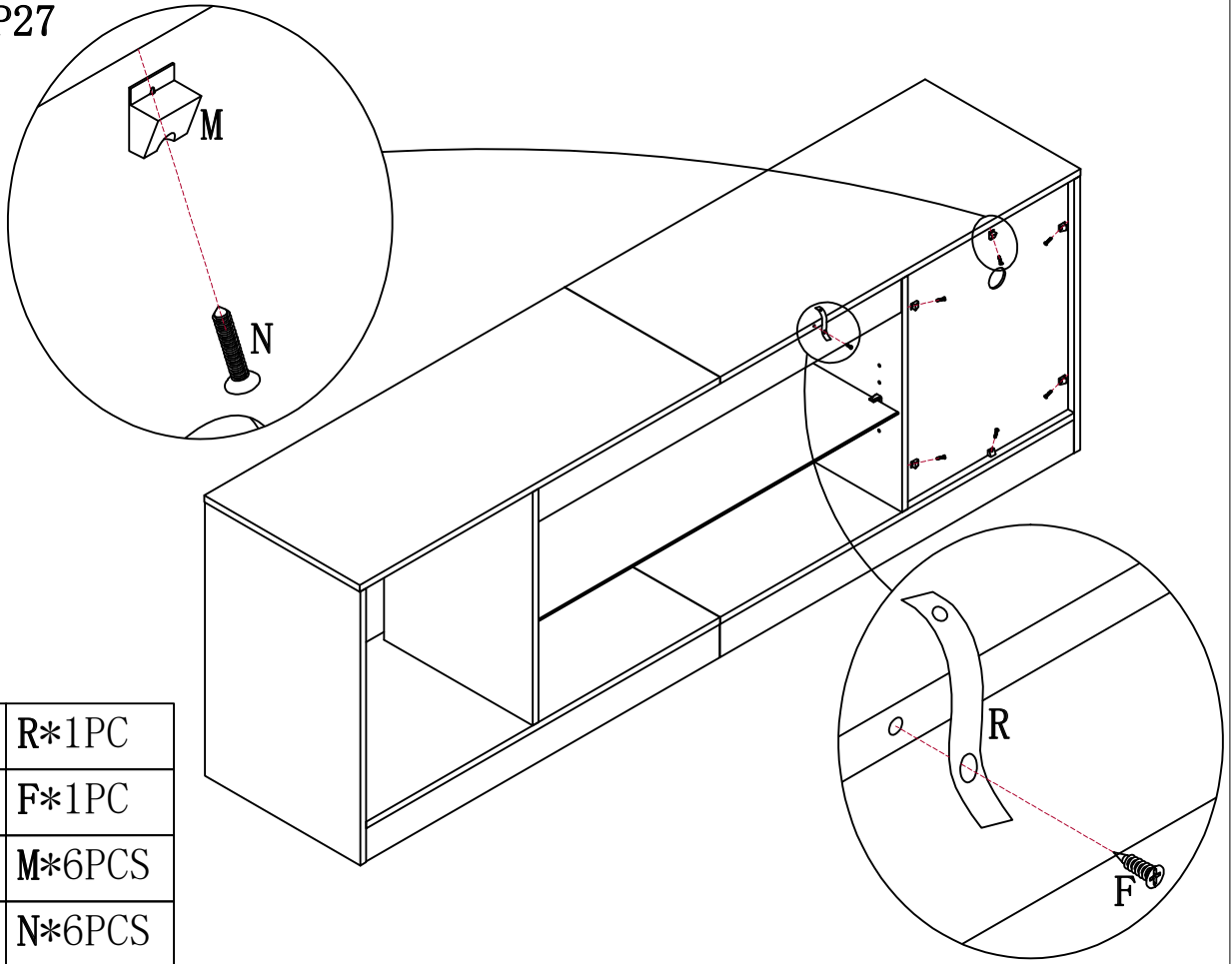

## STEP27



	R*1PC
	F*1PC
	M*6PCS
	N*6PCS

## STEP28

Drill a hole on the wall at the required position for anti-fall device installation.

Bohren Sie ein Loch an der gewünschten Stelle in die Wand, um das Absturzsystem zu installieren.

Percez un trou à l'emplacement requis sur le mur pour l'installation du dispositif anti-chute.

Forare un foro nella posizione richiesta sulla parete per l'installazione del dispositivo anti-caduta.

Taladre un agujero en la posición requerida en la pared para la instalación del dispositivo anti-caída.

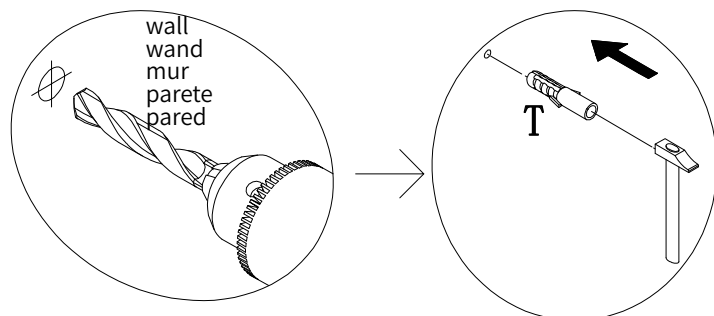
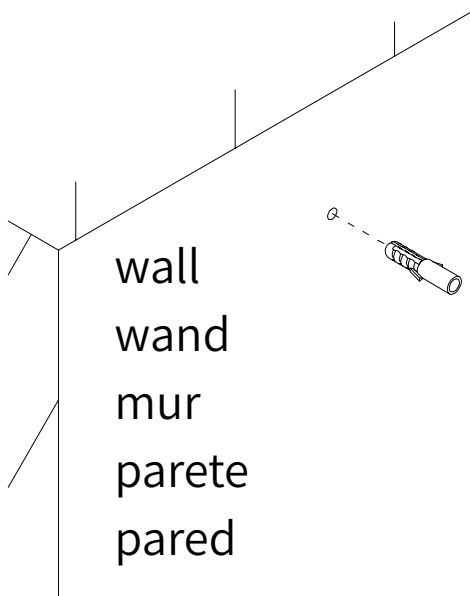

	T*1PC
---	-------

STEP29

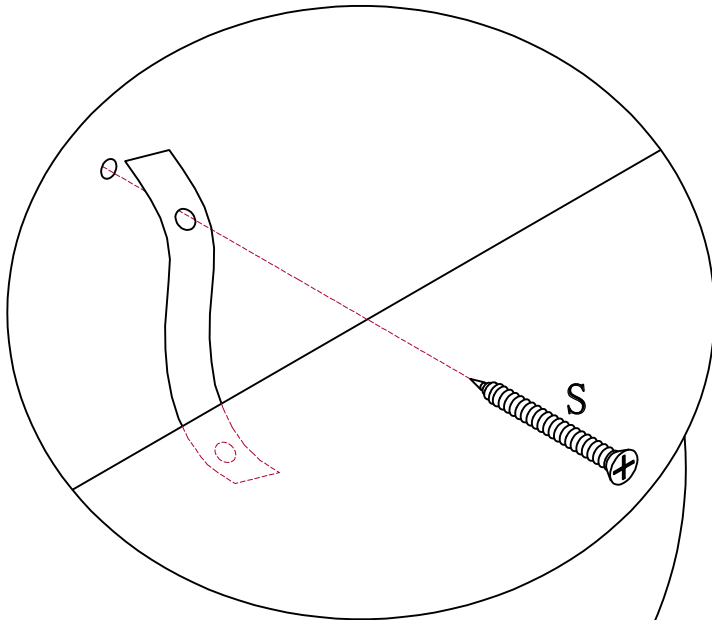

wall  
wand  
mur  
parete  
pared

