

BEDSIDE TABLE





Questions, problems, assembly help, missing parts?

No need to return the product, we will gladly help and ship your replacement parts free of charge  
Please call Customer Service

In order to assist you in a timely manner, please have the following information ready:

Model # \_\_\_\_\_ Part Number or Letter \_\_\_\_\_

Purchased at \_\_\_\_\_ Date of Purchase \_\_\_\_\_

**If you wish to return the product, please contact the retailer where the product was purchased.**

**IMPORTANT** : Please read this manual carefully before beginning assembly of this product. Keep this manual for future reference.

## SAFETY INFORMATION

Identify all the parts and hardware. Do not discard of the packaging until you have checked that you have all of the parts and hardware required. Hardware package may have spare parts.

**WARNING:** This item contains small parts which can be swallowed by children and pets. Keep children and pets away during assembly. To avoid danger of suffocation, always keep plastic bags away from children and pets. We recommend that you assemble this unit on a carpeted floor to avoid scratches. If using power tools, set the tool to low torque to avoid damage.

**May require 2 people for ease of assembly.**

**IMPORTANT** : Please read this manual carefully before beginning assembly of this product. Keep this manual for future reference.

## CARE and MAINTENANCE

Perhaps the greatest environmental damage to wood furniture comes from wide swings in relative humidity (RH) in our homes. Wood absorbs and desorbs water as relative humidity rises and falls, and in doing so it swells and shrinks. Making matters worse, it expands and contracts unequally along different grain directions. As humidity changes, the components of wooden objects are continually pushing and pulling against each other. This pressure often results in parts of furniture no longer fitting together closely or becoming distorted or breaking from their own internal stresses.

The response to relative humidity changes begins with determining the annual average RH for your particular space. Then try to keep the RH in the space where your furniture is as close to that average as possible, generally within about 10% up or down. De-humidify in the summer and humidify in the winter.

Be aware that raising the temperature lowers the humidity and vice versa. Thus, modern heating systems, which can drive down interior RH in the winter, almost invariably cause problems for furniture. To counteract their effect, you can either modify the RH by keeping furniture containing spaces cooler in the winter or most importantly, have a good working humidifier for your home. A humidistat automatically works to balance the humidity in your home so it is constant. Dry indoor air can suck enough moisture from its surroundings to do permanent damage to wood, causing it to crack or split.

Remember, that not all woods are created equal. Two factors that help determine how rapidly a wood will lose moisture are pore size and surface hardness. A piece made from a dense and hard wood will dry less rapidly than pieces made from softer woods.

Furniture that is sealed and lacquered will lose moisture more slowly than an unfinished piece while pieces with veneer finishes are not only stronger, but lose moisture more slowly than other finishes.

### **To help protect your wood furniture, take these steps:**

- Use a humidifier, preferably one with an automatic control system that can sense the humidity level and adjust itself accordingly. Don't over-humidify; that can damage wood by causing it to expand and contract.
- Keep furniture out of direct sunlight, which can cause it to dry out, crack and warp.
- If you can avoid it, don't put furniture near heating vents. If you must, keep the piece 3 to 4 inches away from the wall, giving the heat and air space to circulate.
- Dust with soft dry cloth.
- Do not use liquid or aerosol products.
- To avoid marking, do not place rubber on surface (foot pads, etc.)
- For soil build-up, wipe with damp cloth & dry.
- Do not use abrasive cleaners.

# PRE-ASSEMBLY INFORMATION

## PART DESCRIPTION

**A**

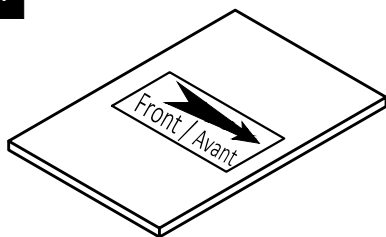

TOP  
QTY 1

**BL**

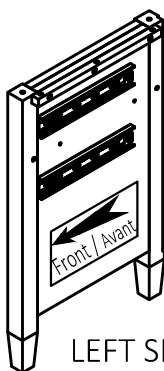

LEFT SIDE  
QTY 1

**BR**

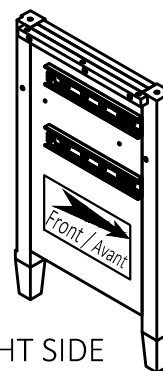

RIGHT SIDE  
QTY 1

**C**

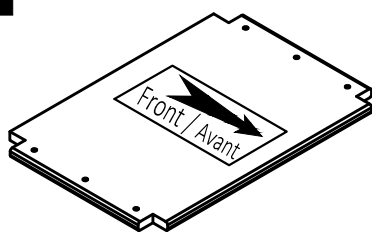

BOTTOM SHELF  
QTY 1

**D**

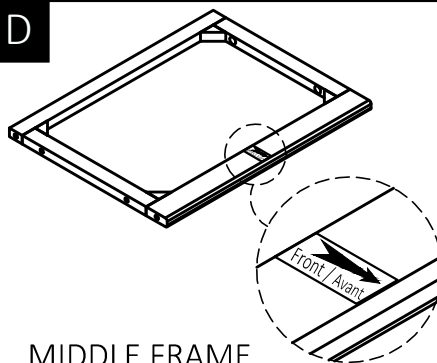

MIDDLE FRAME  
QTY 1

**E**

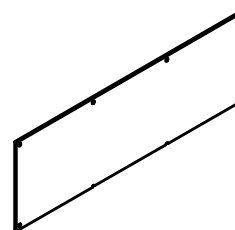

TOP BACK PANEL  
QTY 1

**F**

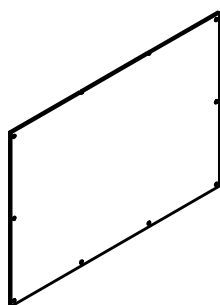

BOTTOM BACK PANEL  
QTY 1

**G**

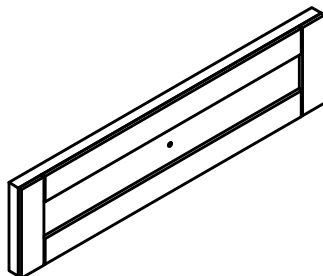

DRAWER FRONT  
QTY 2

**HL**

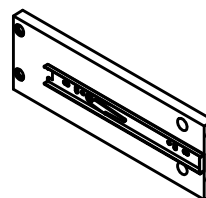

LEFT DRAWER SIDE  
QTY 2

**Hr**

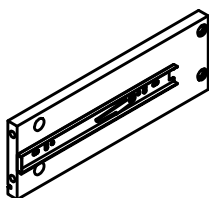

RIGHT DRAWER SIDE  
QTY 2

**I**

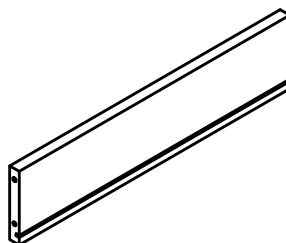

DRAWER BACK  
QTY 2

**J**

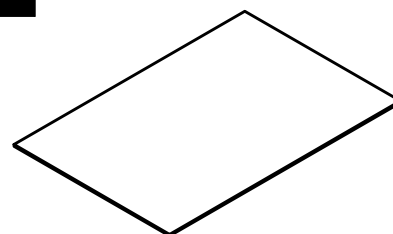

DRAWER BOTTOM  
QTY 2

**NEED HELP?** For help with assembly or if you are missing a part,  
Please call customer service

# PRE-ASSEMBLY INFORMATION

## HARDWARE DESCRIPTION

1

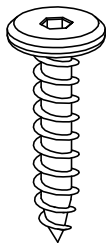

ALLEN KEY SCREW  
M6 X 30mm  
QTY 24

2

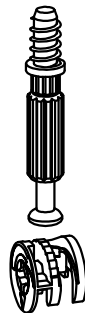

CAM LOCK PIN  
CAM LOCK  
QTY 8 SETS

3



WOOD DOWEL  
Ø8 X 30mm  
QTY 8

4



ALLEN KEY  
QTY 1

5

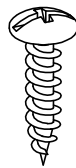

PHILLIPS SCREW ROUND HEAD  
M4 X 15mm  
QTY 16

6

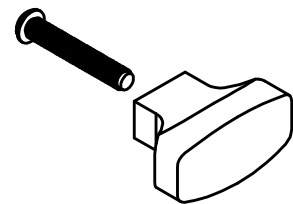

HANDLE  
M4 X 25 mm  
QTY 2 SETS

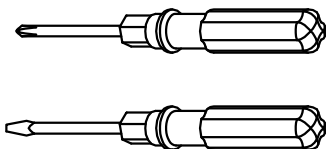

Required -  
Flathead screwdriver  
Phillips screwdriver  
Rubber mallet  
**Not Included**

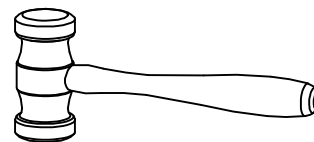

NEED HELP? For help with assembly or if you are missing a part,  
Please call customer service

# COMPONENTS-KEY DIAGRAM

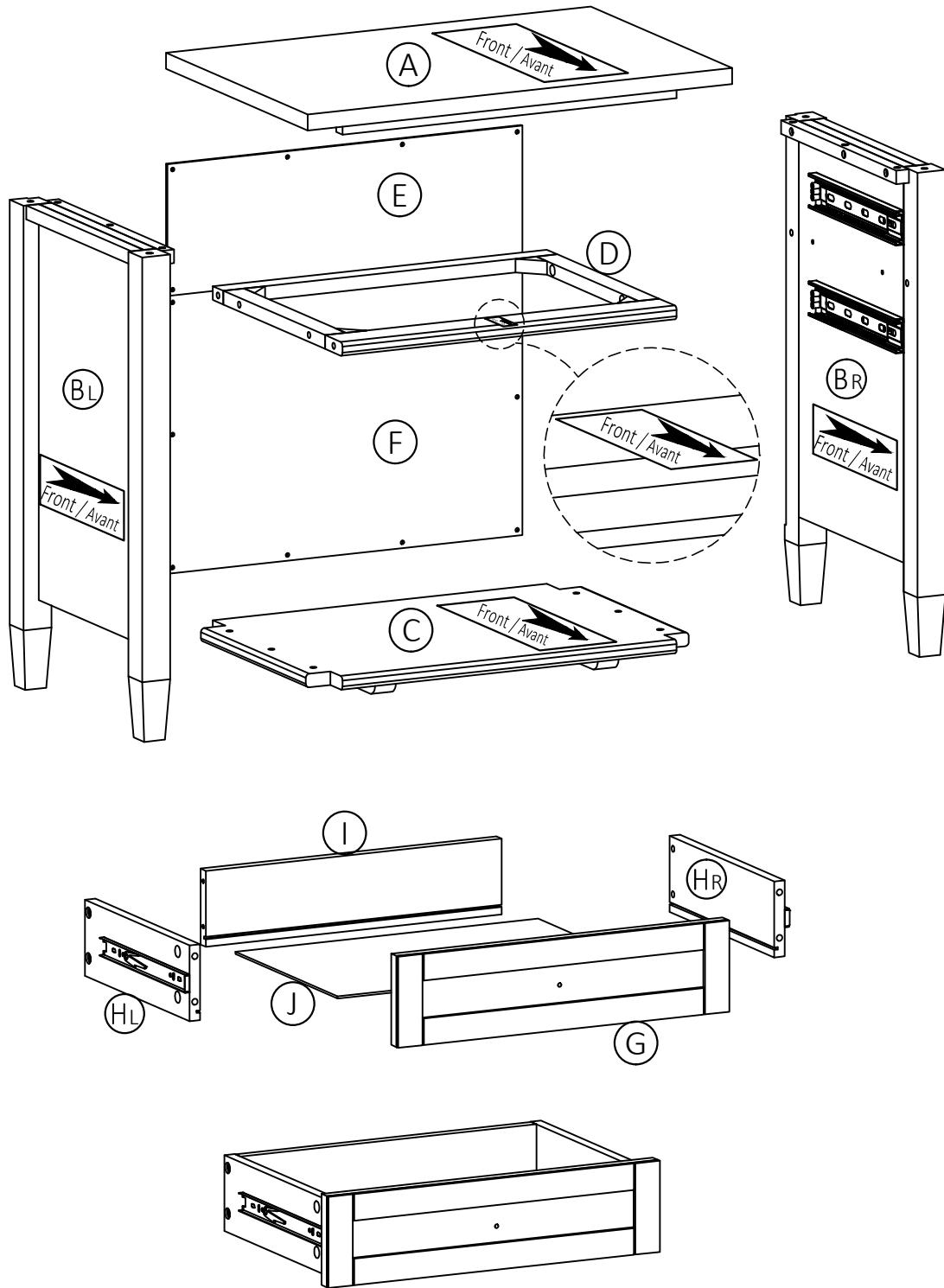

# ASSEMBLY

## STEP-1

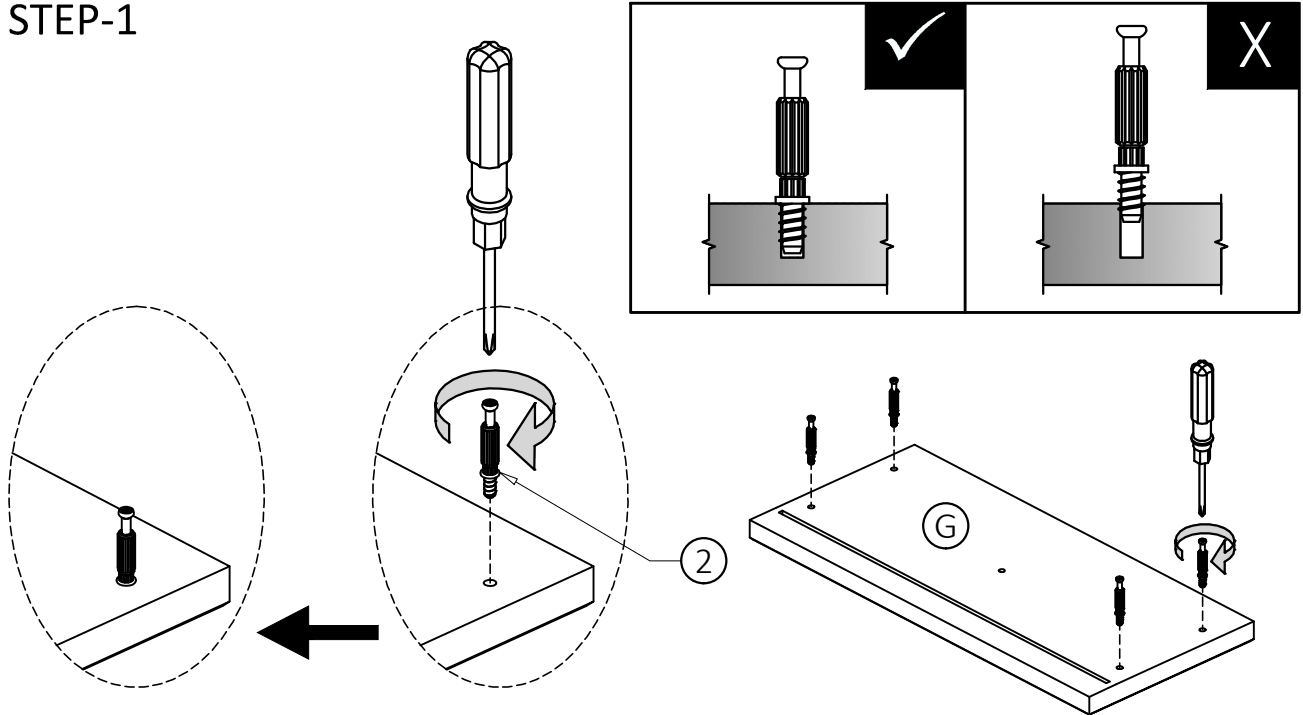

1. Attach four Cam Lock Pins (2) to pre-drilled holes at back of Drawer Front (G).
2. Use Phillips screwdriver to secure Cam Lock Pins.

## STEP-2

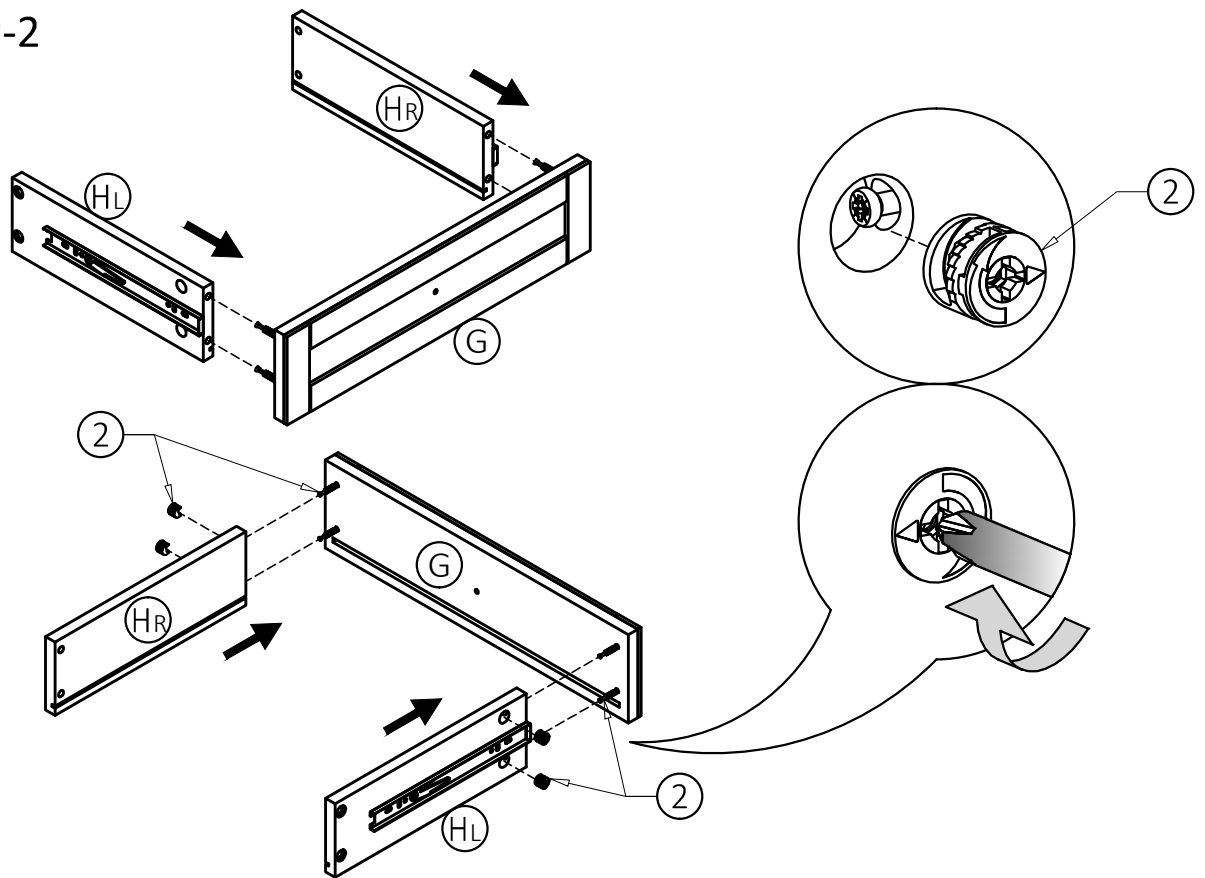

1. Align Cam Lock Pins with drilled holes and attach Drawer Sides (HL, HR).
2. Insert two Cam Locks (2) into drilled holes on each Drawer Side (HL, HR).
3. Use Phillips screwdriver to secure Cam Locks.



## ASSEMBLY

### STEP-3

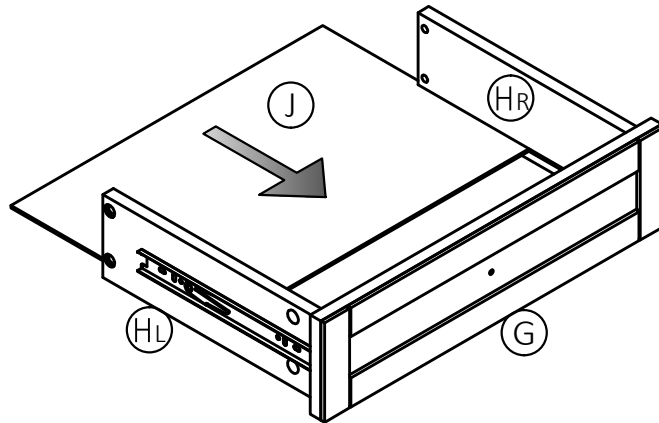

1. Slide Drawer Bottom (J) firmly into slots on Drawer Sides (HL), (HR) and Drawer Front (G).

### STEP-4

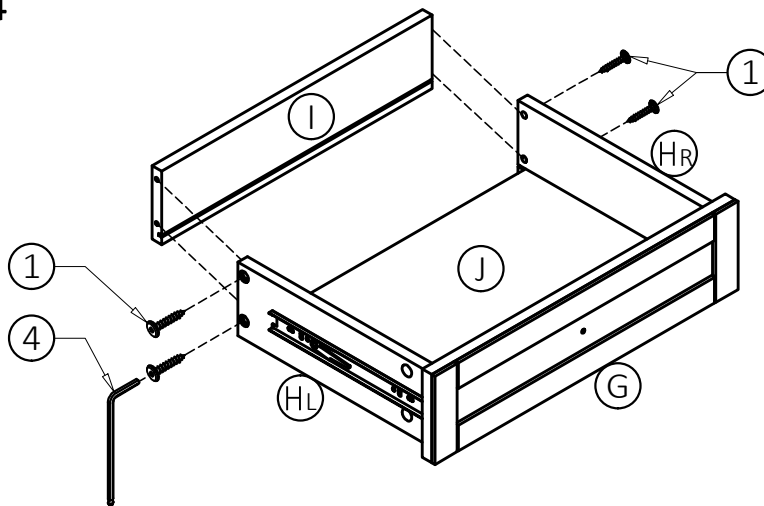

1. Align Drawer Back (I) with Drawer Bottom (J) and press firmly into slot .
2. Attach Drawer Back using two Allen Key Screws (1) through drilled holes on each Drawer Side (HL), (HR) .
3. Use Allen Key (4) to tighten Screws. Do not over-tighten

### STEP-5

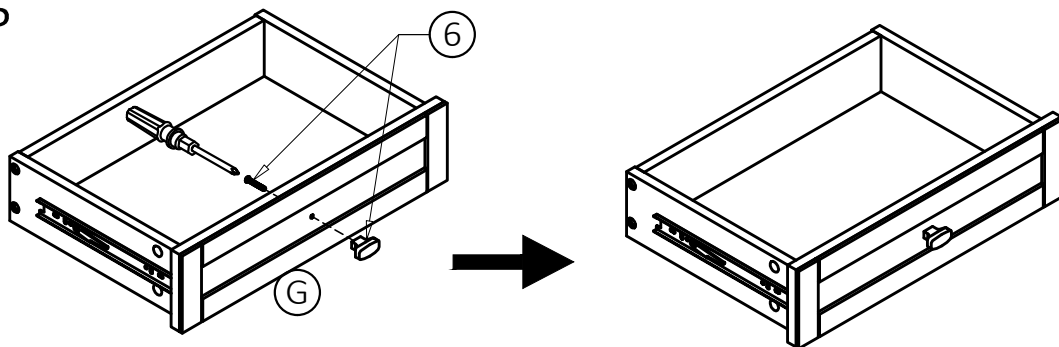

1. Use Phillips screwdriver to attach Handle (6) to Drawer Front (G) .

**Repeat Step-1 to Step-5 for the second Drawer .**

## ASSEMBLY

### STEP-6

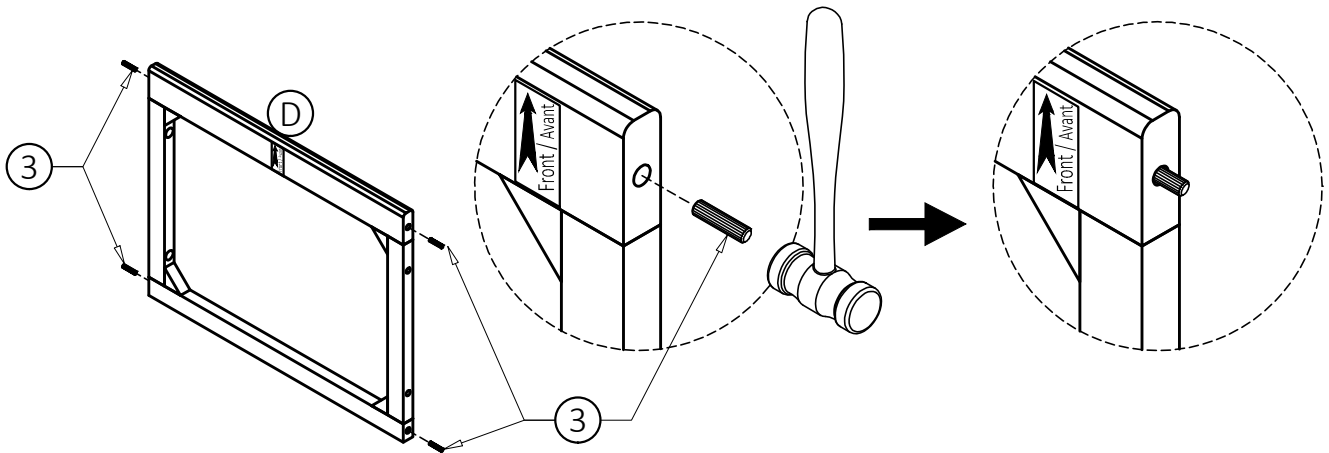

1. Insert four Wood Dowels (3) into drilled holes on Middle Frame (D).
2. Use rubber mallet to tap Dowels (3) into bottom of holes securely. 1/2 length of Dowels should be exposed.

### STEP-7

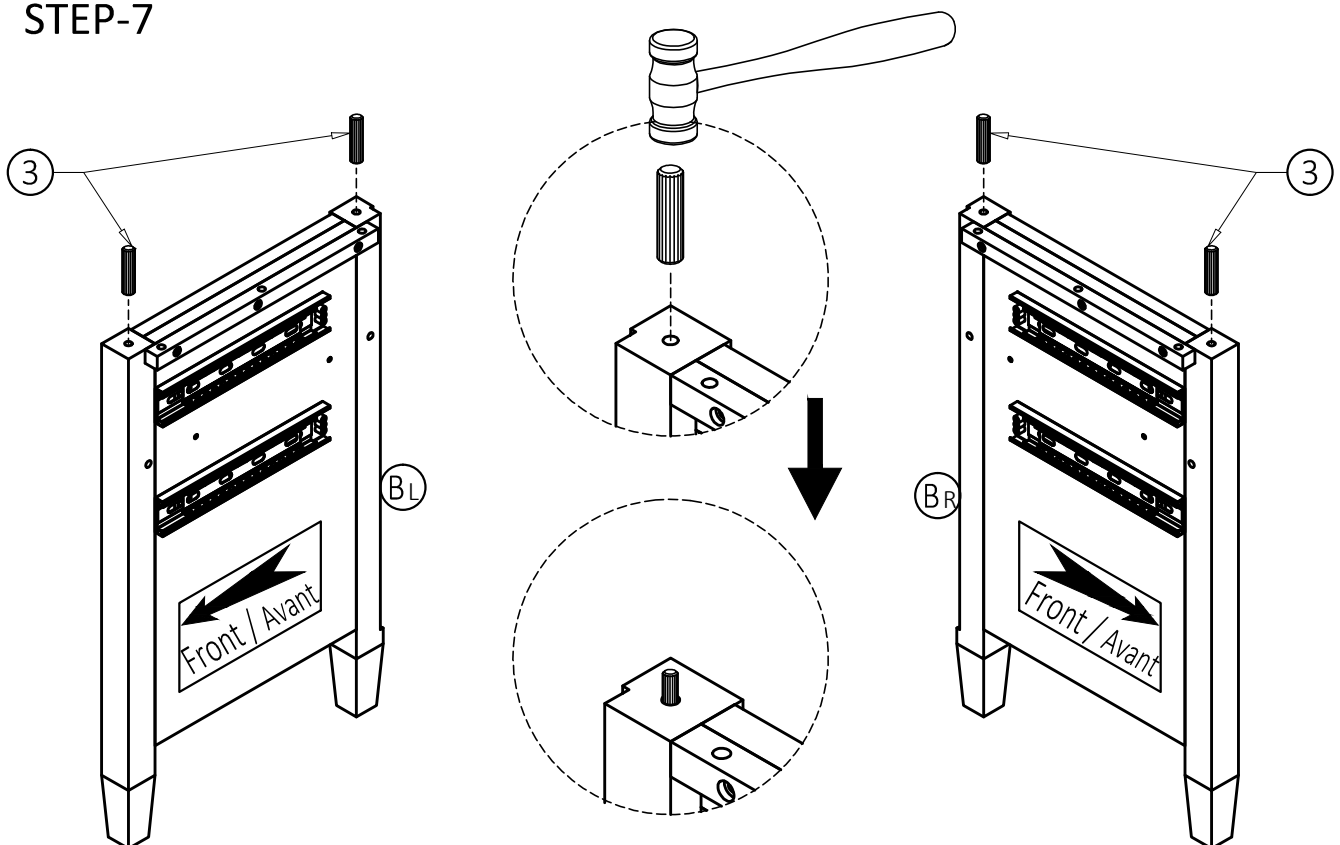

1. Insert two Wood Dowels (3) into drilled holes on each Side (BL, BR).
2. Use rubber mallet to tap Dowels (3) into bottom of holes securely. 1/2 length of Dowels should be exposed.

# ASSEMBLY

## STEP-8

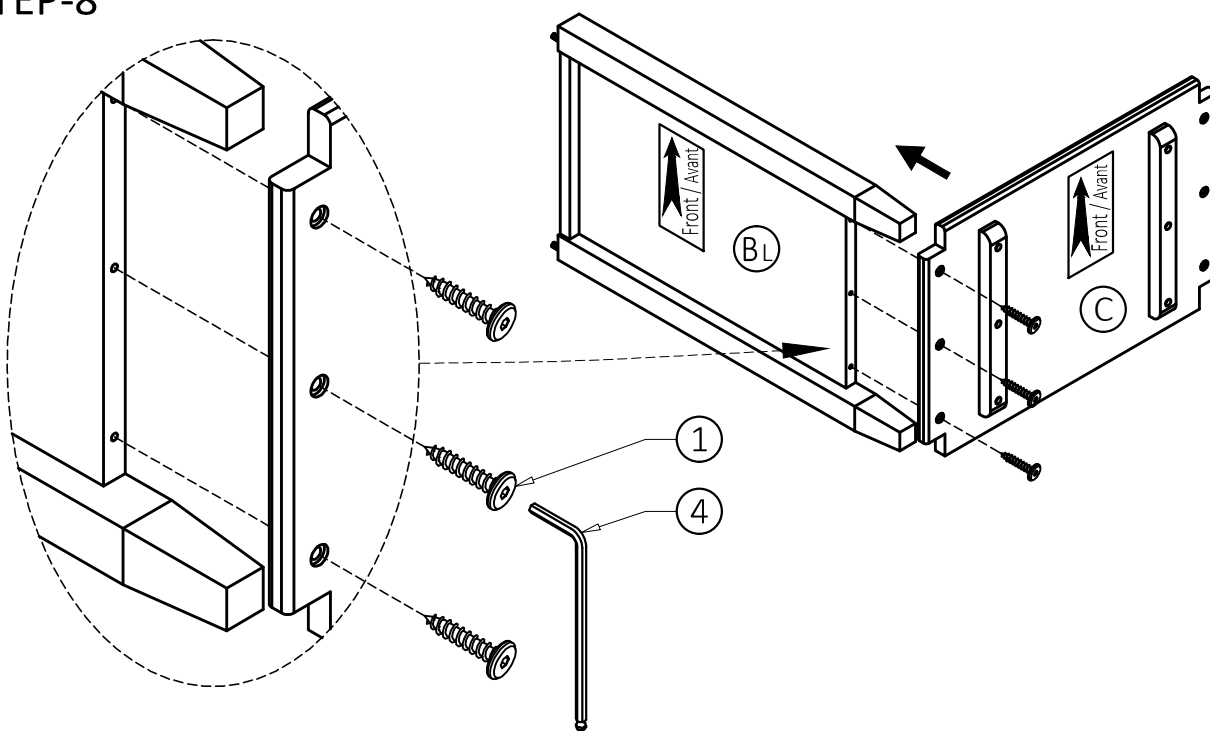

1. Attach Bottom Shelf (C) to Left Side (BL) using three Allen Key Screws (1).
2. Use Allen Key (4) to tighten Screws. Do not over-tighten.

## STEP-9

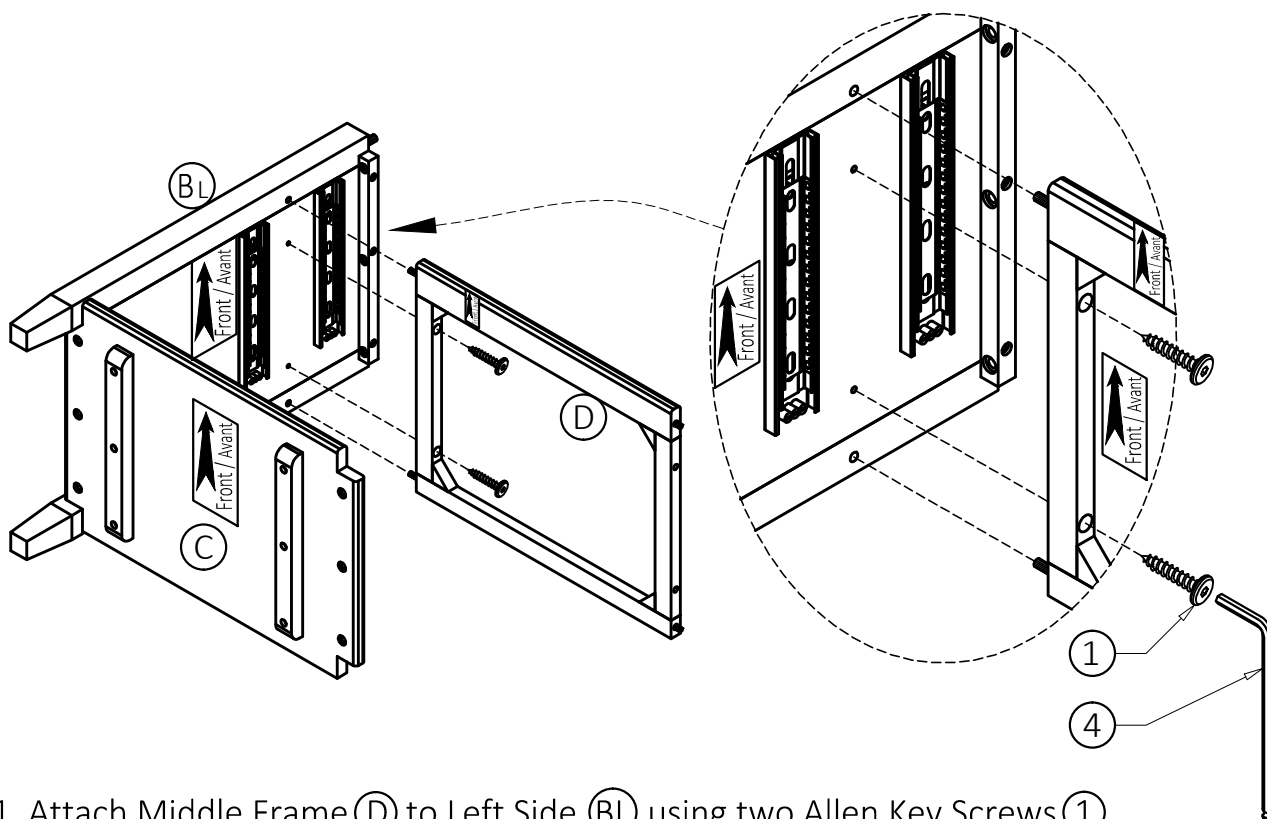

1. Attach Middle Frame (D) to Left Side (BL) using two Allen Key Screws (1).
2. Use Allen Key (4) to tighten Screws. Do not over-tighten.

# ASSEMBLY

## STEP-10

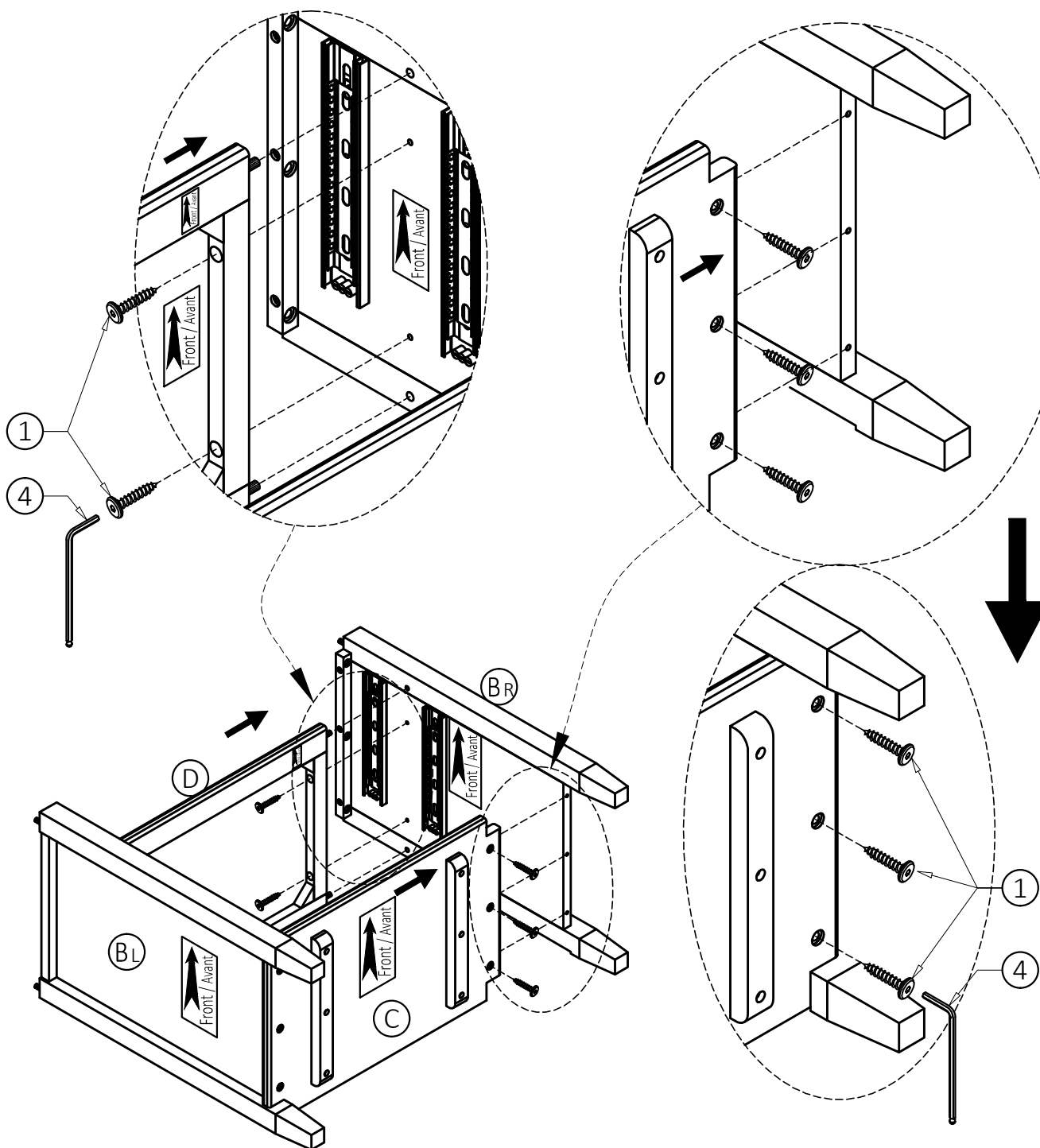

1. Attach Middle Frame (D) and Bottom Shelf (C) to Sides (BR) using five Allen Key Screws (1) (two Screws / Middle Frame, three Screws / Bottom Shelf).
3. Use Allen Key (4) to tighten Screws. Do not over-tighten.

# ASSEMBLY

## STEP-11

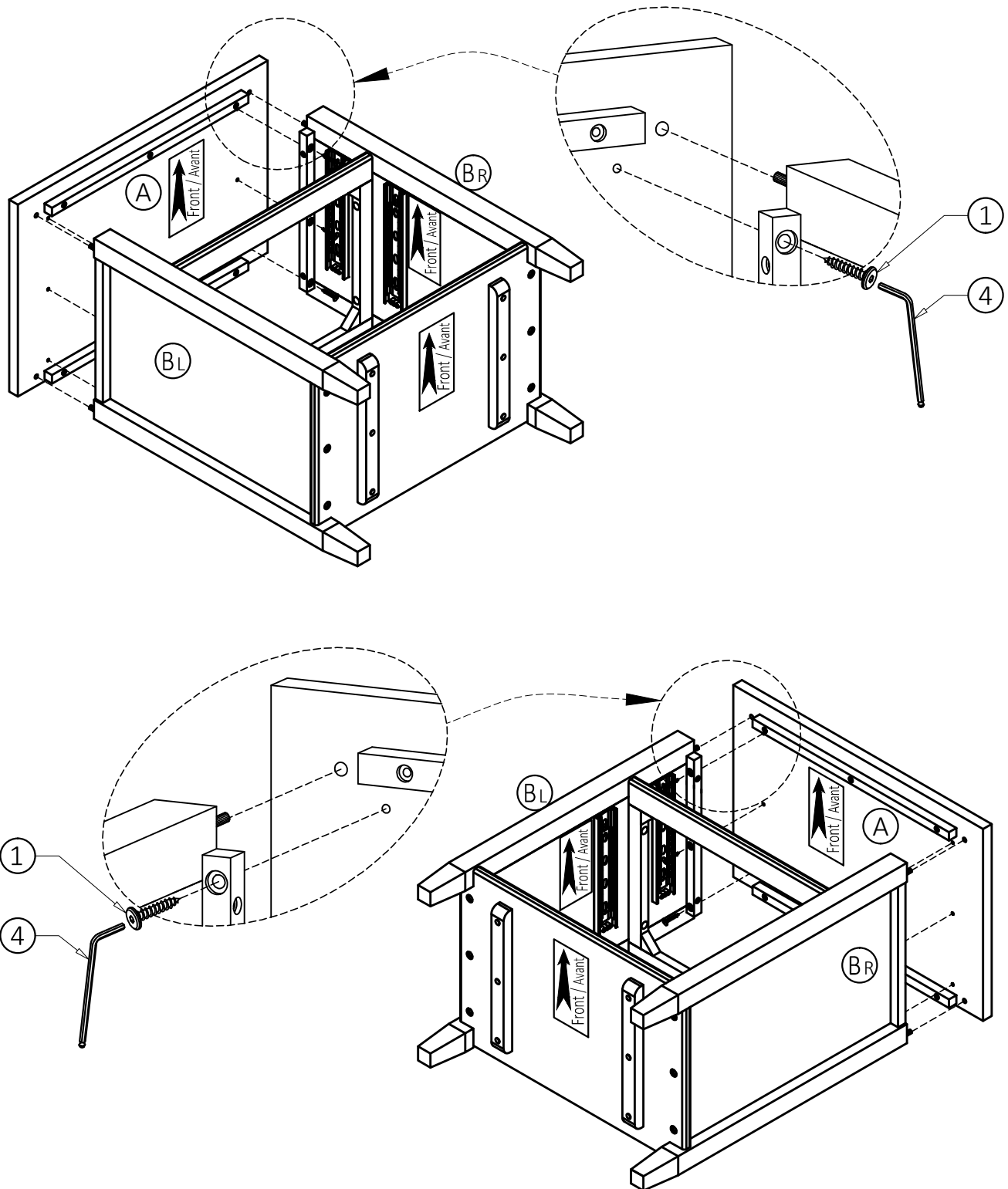

1. Attach Top (A) to Sides (BL), (BR) using six Allen Key Screws (1)  
( three Screws / each Side ).
3. Use Allen Key (4) to tighten Screws. Do not over-tighten.

# ASSEMBLY

## STEP-12

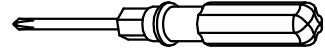

**NOTE:** The screwdriver is not included in the hardware pack.

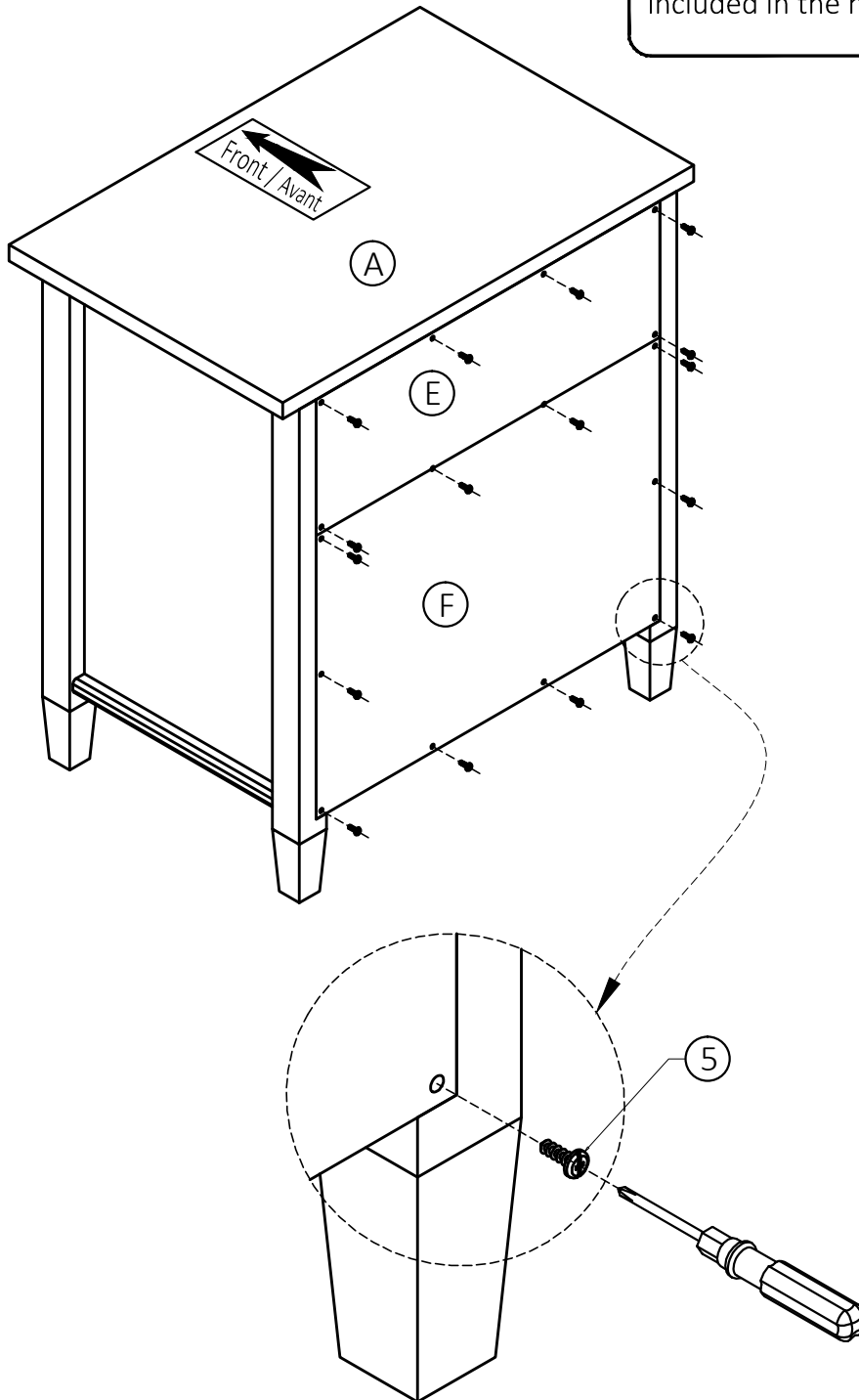

1. Attach Back Panels (E), (F) to back frame of storage using sixteen Phillips Screws Round Head (5) through drilled holes.
2. Use Phillips Screwdriver to tighten Screws.

# ASSEMBLY

## STEP-13

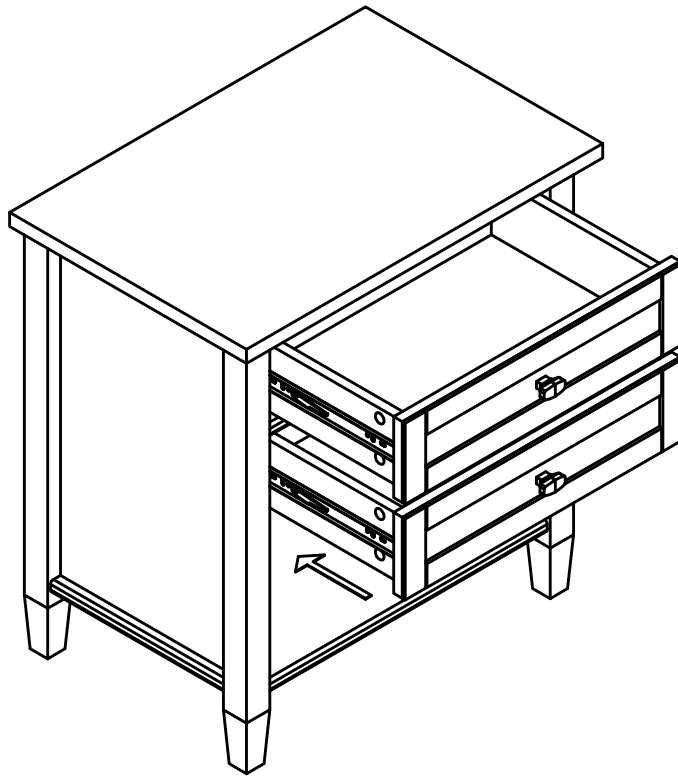

1. Insert assembled Drawers into glides on assembled Bedside.

## WARRANTY

Thank you for purchasing our product. These products have been made to demanding, high-quality standards and are guaranteed for domestic use against manufacturing faults for a period of 12 months from the date of purchase. This warranty does not affect your statutory rights.

We reserve the right to repair or replace the defective product, at its discretion.

This product is guaranteed for 12 months if used for normal purposes. Any warranty is invalid if the product has been overloaded or subject to neglect, improper use or an attempted repair by other than an authorized agent. Heavy-duty or daily professional/commercial usage are not guaranteed.

Due to continuous product improvement, we reserve the right to change the product specifications without prior notice.