

ADJUSTABLE LYING BED

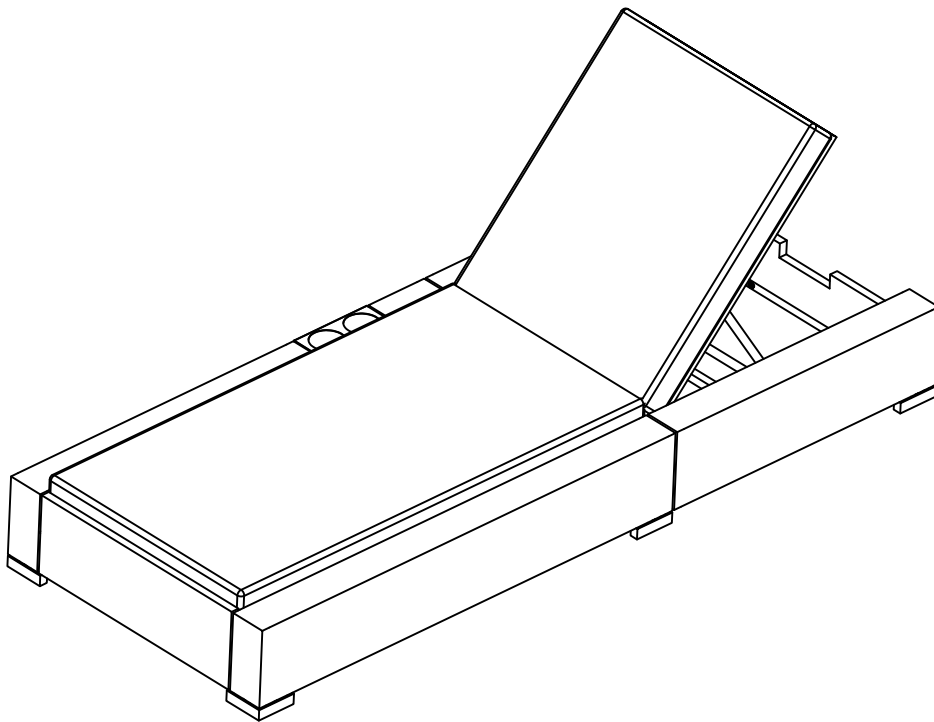

ATTENTION Section:

1. If you encounter any issues, such as missing accessories or damaged parts, please contact us immediately and include pictures (email: jm@nicesoulfurniture.com)

Assembly Instructions:

1. Assembly requires two people to complete.
2. For optimal assembly, we highly recommend using the provided Allen key. If using a power tool, please set it to a low speed to prevent any damage
3. Do not fully tighten the screws until all screws are properly aligned with their holes.

PARTS LIST OF BOX

A

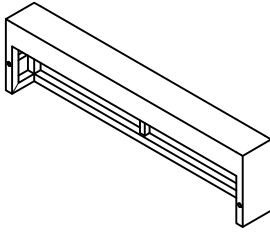

1pc

B

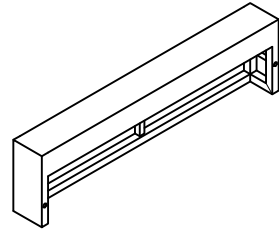

1pc

C

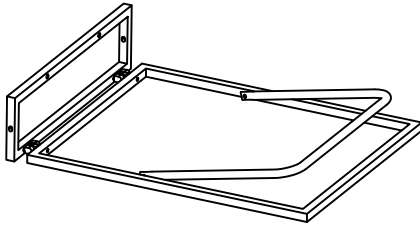

1pc

D

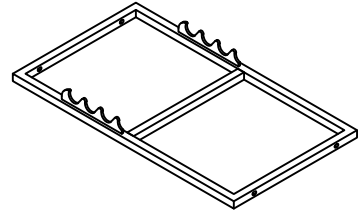

1pc

E

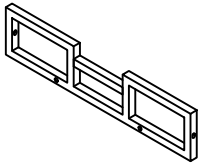

1pc

F

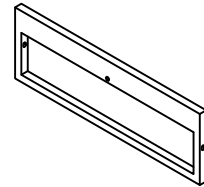

1pc

G

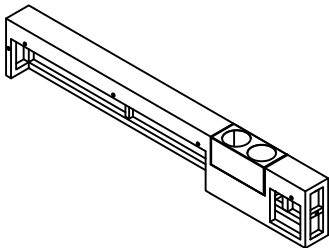

1pc

H

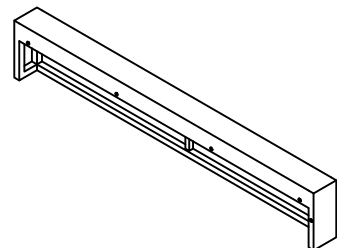

1pc

I

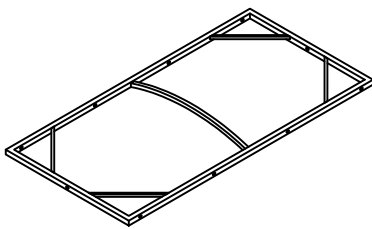

1pc

J

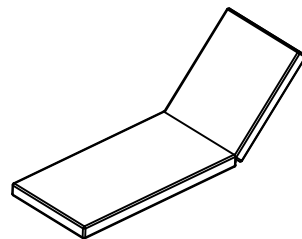

1pc

①

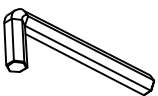

1pc

③



34pcs

④



22pcs



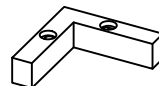

⑤

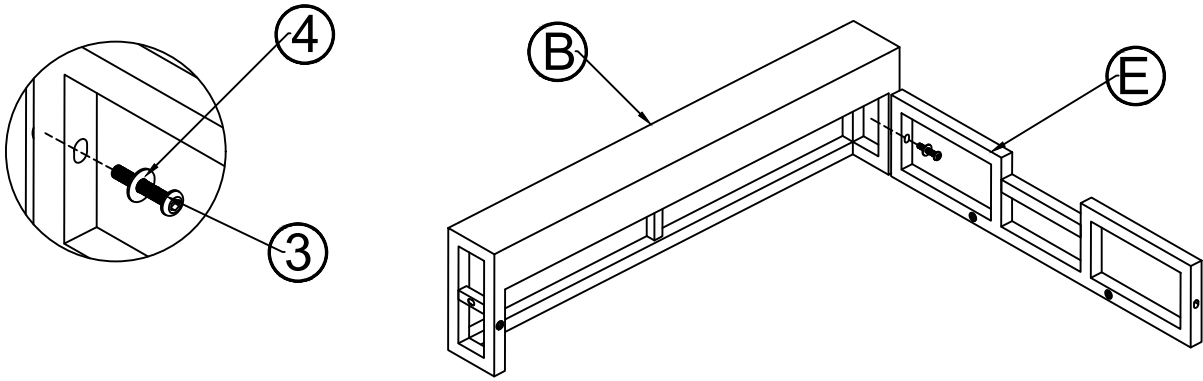

6pcs

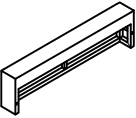
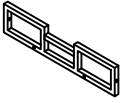



STEP 1

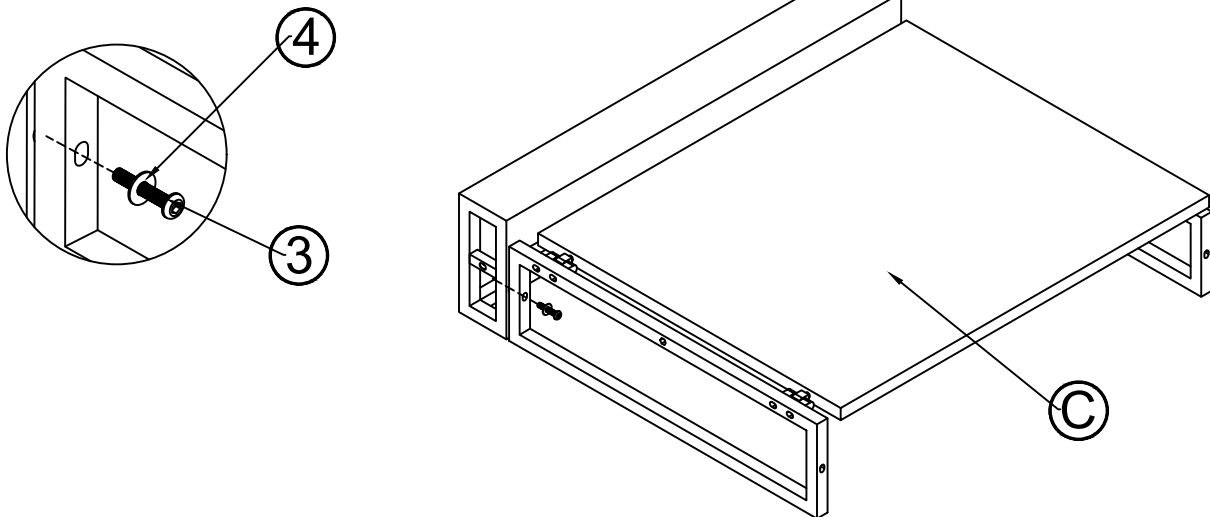

B	1pc	E	1pc	①	1pc	③	1pc	④	1pc
					M6		M6*35		M6

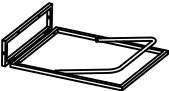
STEP 2





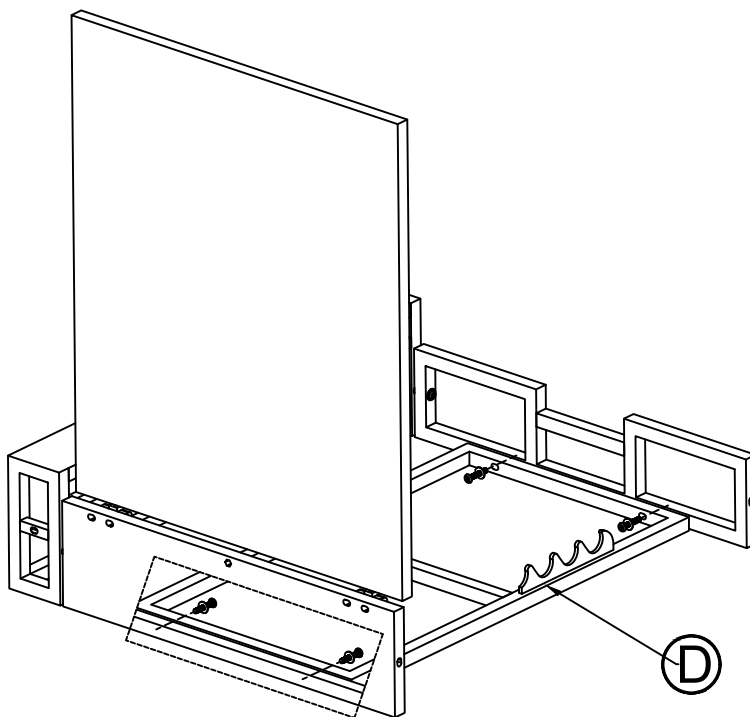
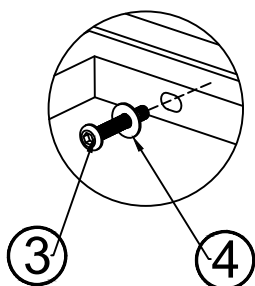

C	1pc	①	1pc	③	1pc	④	1pc
			M6		M6*35		M6

Do not fully tighten all screws until assembly is completed.

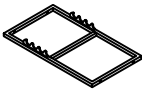



STEP 3

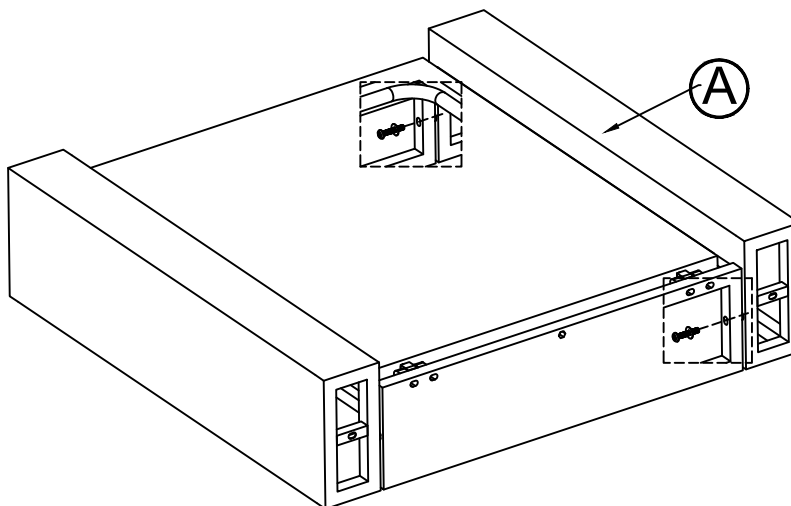
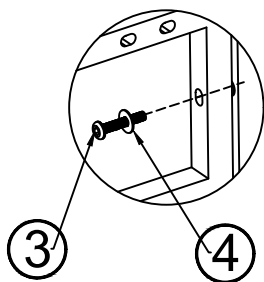

D	1pc	①	1pc	③	4pcs	④	4pcs
			M6		M6*35		M6

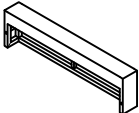
STEP 4





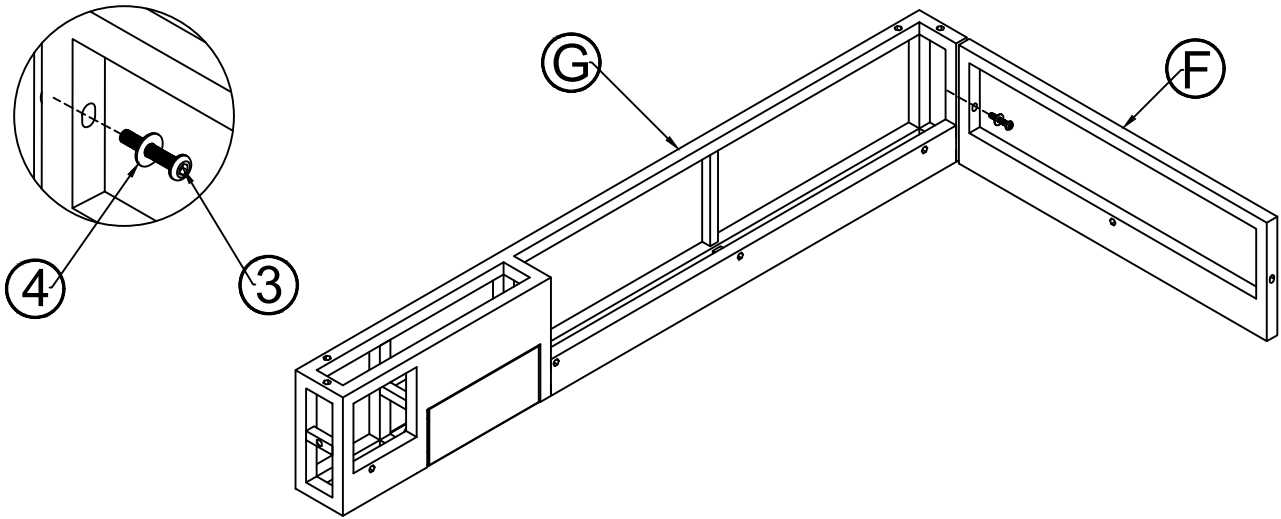

A	1pc	①	1pc	③	2pcs	④	2pcs
			M6		M6*35		M6

Do not fully tighten all screws until assembly is completed.

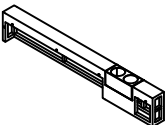
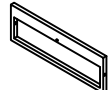



STEP 5

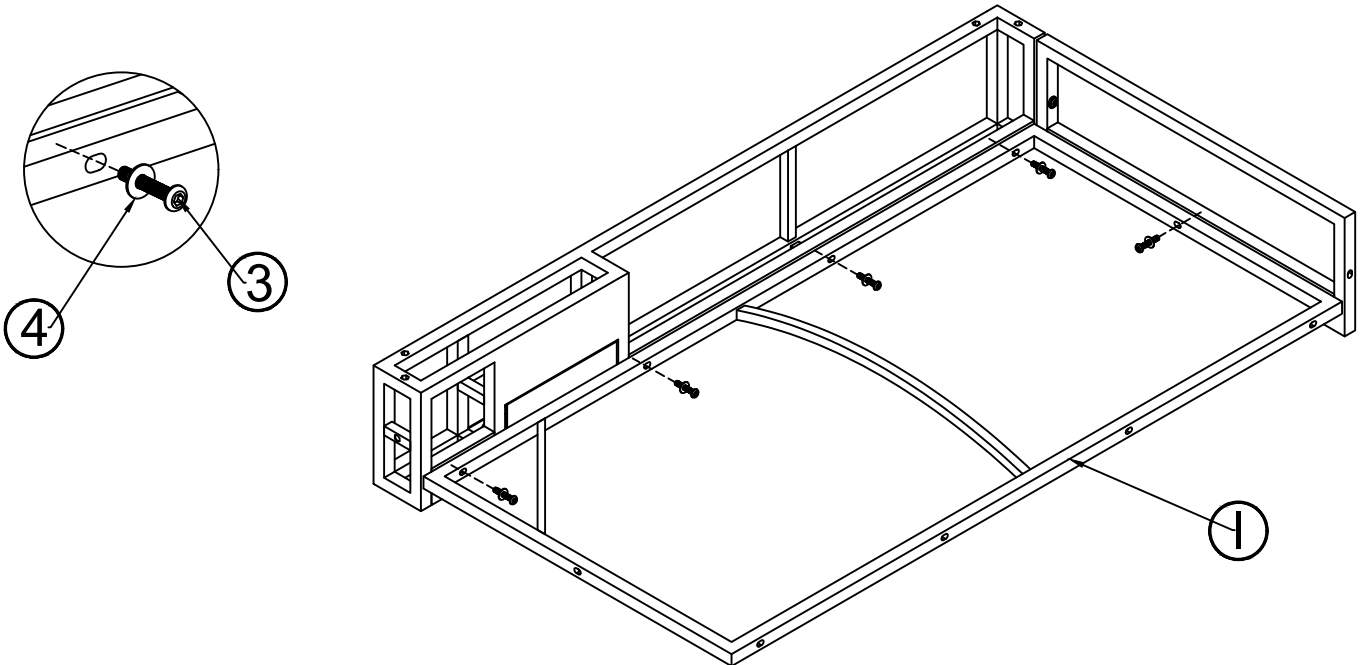

G	1pc	F	1pc	①	1pc	③	1pc	④	1pc
					M6		M6*35		M6

STEP 6





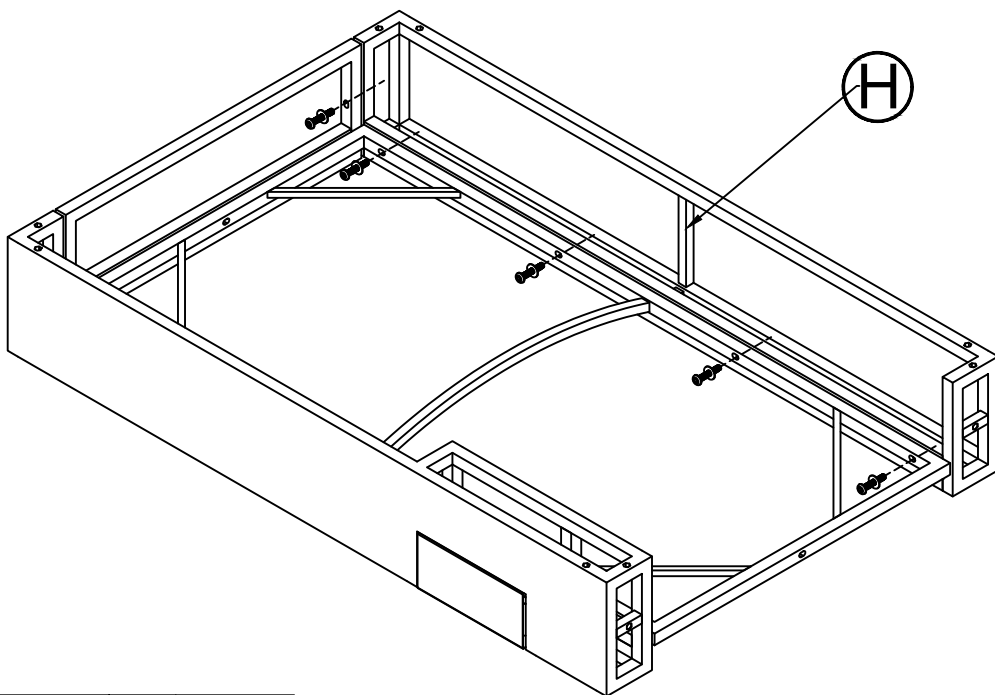
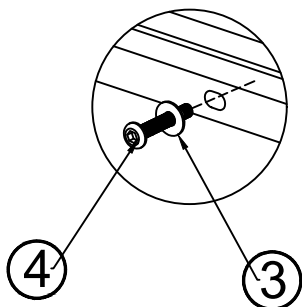

I	1pc	①	1pc	③	5pcs	④	5pcs
			M6		M6*35		M6

Do not fully tighten all screws until assembly is completed.

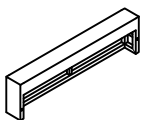

STEP 7

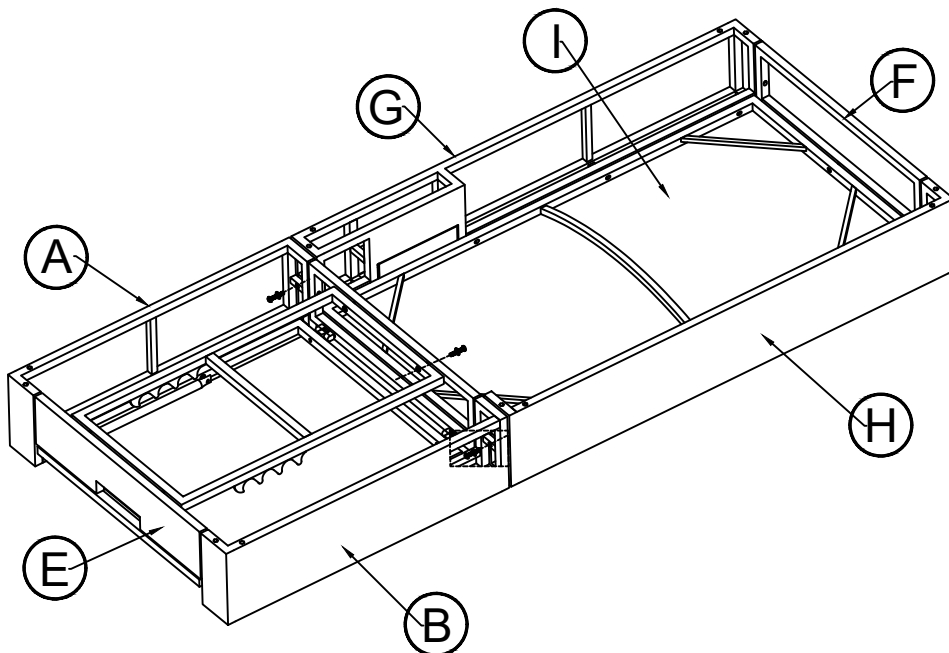
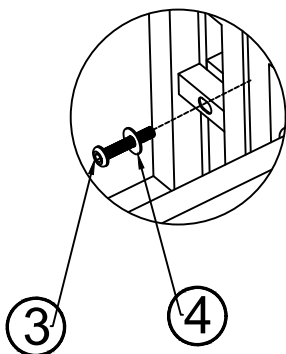

H	1pc	①	1pc	③	5pcs	④	5pcs
			M6		M6*35		M6

STEP 8





①	1pc	③	3pcs	④	3pcs
			M6*35		M6

Do not fully tighten all screws until assembly is completed.

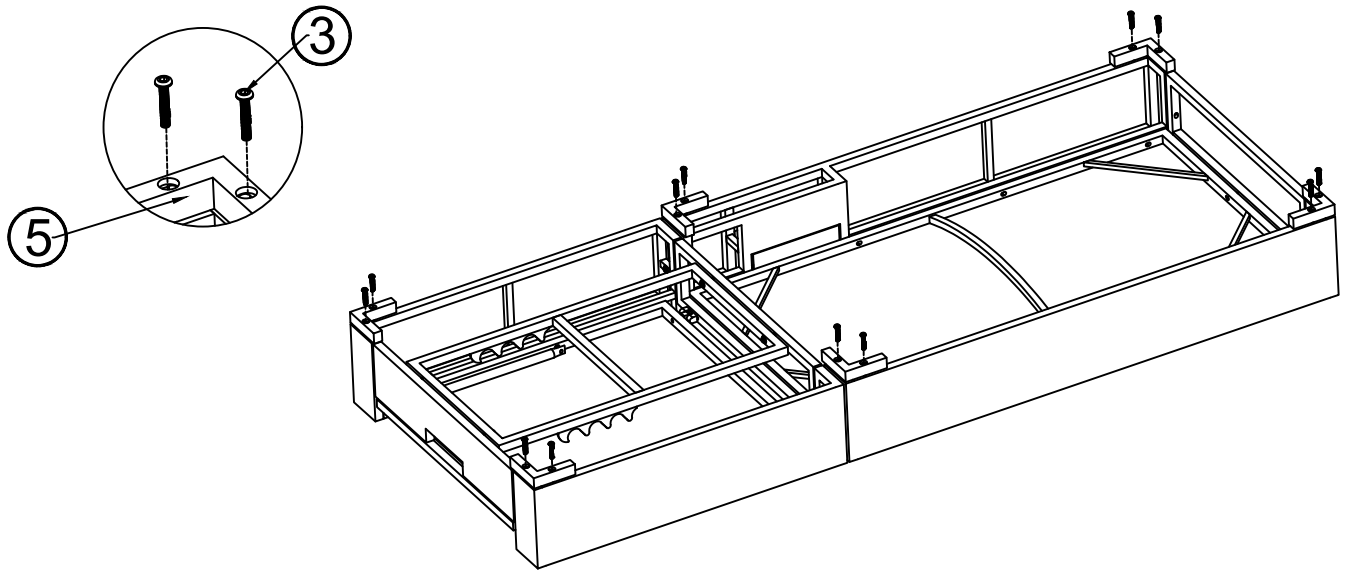
STEP 9

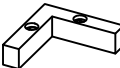

①	1pc	③	12pcs	⑤	6pcs
					
M6		M6*35			

STEP 10

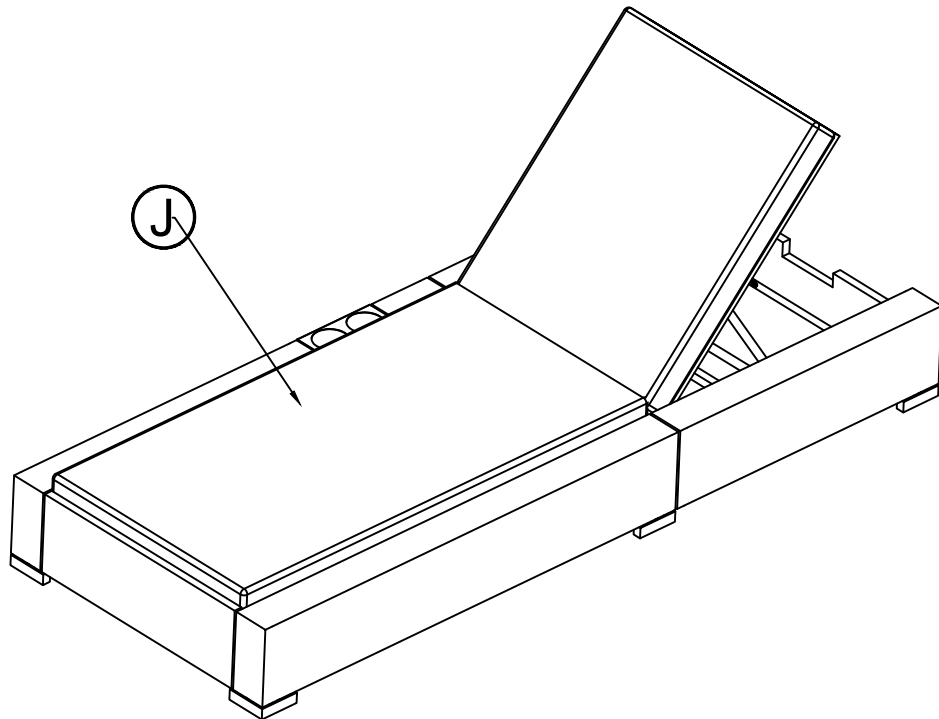

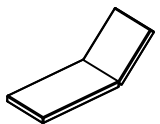
J	1pc
	

Do not fully tighten all screws until assembly is completed.