

EASTERN KING SIZE BED

ASSEMBLY INSTRUCTIONS



ASSEMBLY TIPS:

- 1.Remove hardware from box and sort by size.
- 2.Please check to see that all hardware and parts are present prior to start of assembly.
- 3.Please follow attached instructions in the same sequence as numbered to assure fast & easy assembly.



Warning!

- 1.Don't attempt to repair or modify parts that are broken or defective. Please contact the store immediately.
- 2.This product is for home use only and not intended for commercial establishment.





ASSEMBLY TIME 20 MINUTES

PARTS IDENTIFICATION

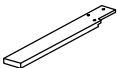
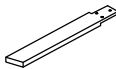
B1 (BOX 1)

- | | | | |
|---|---|---------------------|-----|
| A |  | HEADBOARD PANEL | 1PC |
| B |  | RIGHT HEADBOARD LEG | 1PC |
| C |  | LEFT HEADBOARD LEG | 1PC |



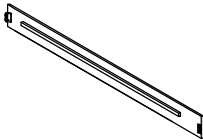
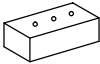
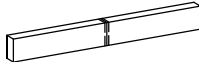
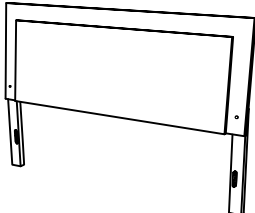

B2 (BOX 2)

- | | | | |
|---|---|-------------------------------|------|
| D |  | BED SLAT | 4PCS |
| E |  | BED SLAT SUPPORT WITH LEVELER | 8PCS |



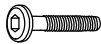

- | | | | |
|----|--|-----------------------------------|------|
| F |  | BED RAIL | 2PCS |
| G |  | FOOTBOARD LEG | 2PCS |
| H |  | FOOTBOARD PANEL | 1PC |
| HB |  | *FROM BOX 1
HEADBOARD COMPLETE | 1PC |

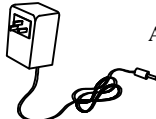
HARDWARE IDENTIFICATION

Z - B1 (BOX 1) - Hardware pack is located in (B1)

- | | | | |
|---|---|--------------|------|
| 1 |  | BOLT | |
| 2 |  | ALLEN WRENCH | 1PC |
| 3 |  | FLAT WASHER | 6PCS |
| 4 |  | LOCK WASHER | 6PCS |
| 5 |  | ADAPTOR PLUG | 1PC |

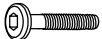
Z - B2 (BOX 2) - Hardware pack is located in (B2)

- | | | | |
|----|--|-----------------------|------|
| 6 |  | SHORT FLAT HEAD SCREW | 8PCS |
| 7 |  | LONG FLAT HEAD SCREW | 6PCS |
| 8 |  | BOLT | 8PCS |
| 9 |  | SMALL ALLEN WRENCH | 1PC |
| 10 |  | BIG ALLEN WRENCH | 1PC |

NOTE: PHILLIPS HEAD SCREW DRIVER IS REQUIRED IN THE ASSEMBLY PROCESS. HOWEVER, MANUFACTURER DOES NOT PROVIDE THIS ITEM.

BOX 1

STEP 1

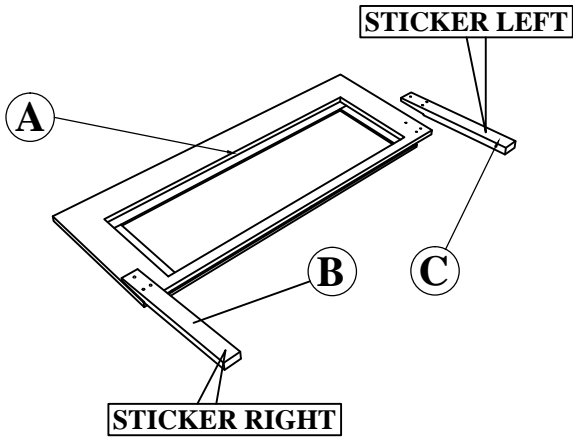

**BACK VIEW

**Please take note the marking on the leg **

STEP 2

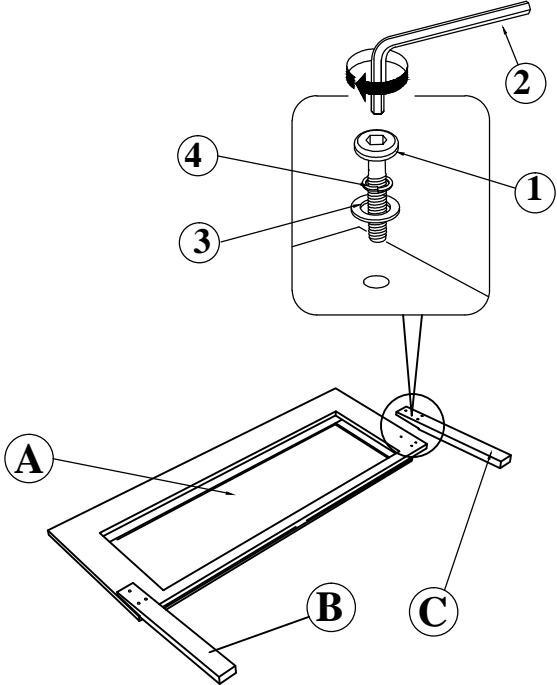

IF PURCHASE HEADBOARD ONLY, SKIP BELOW STEPS

BOX 1 & BOX 2

STEP 3

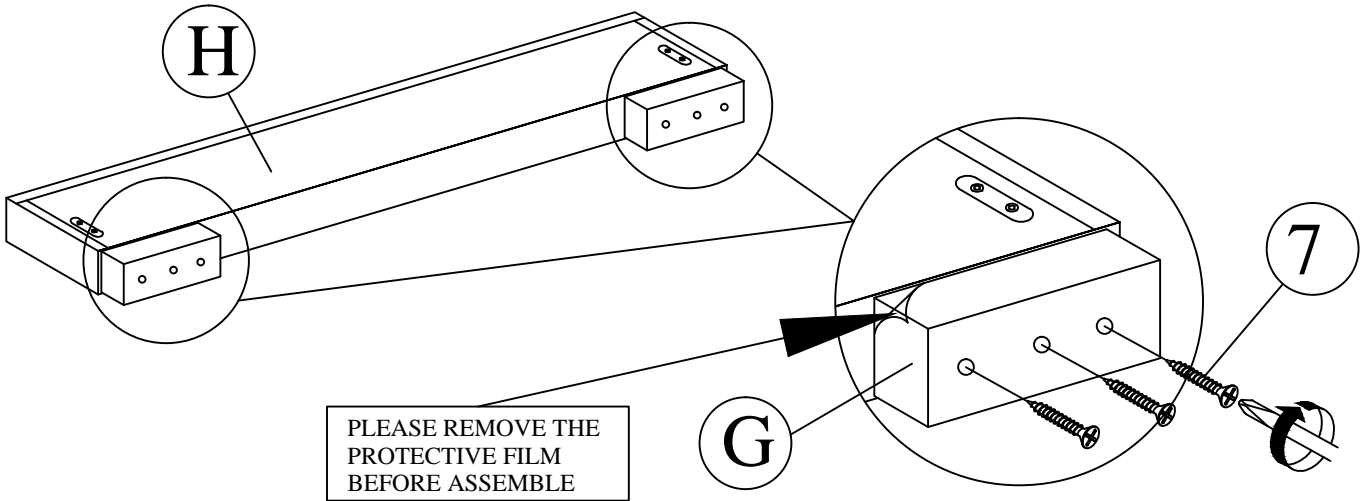

STEP 4

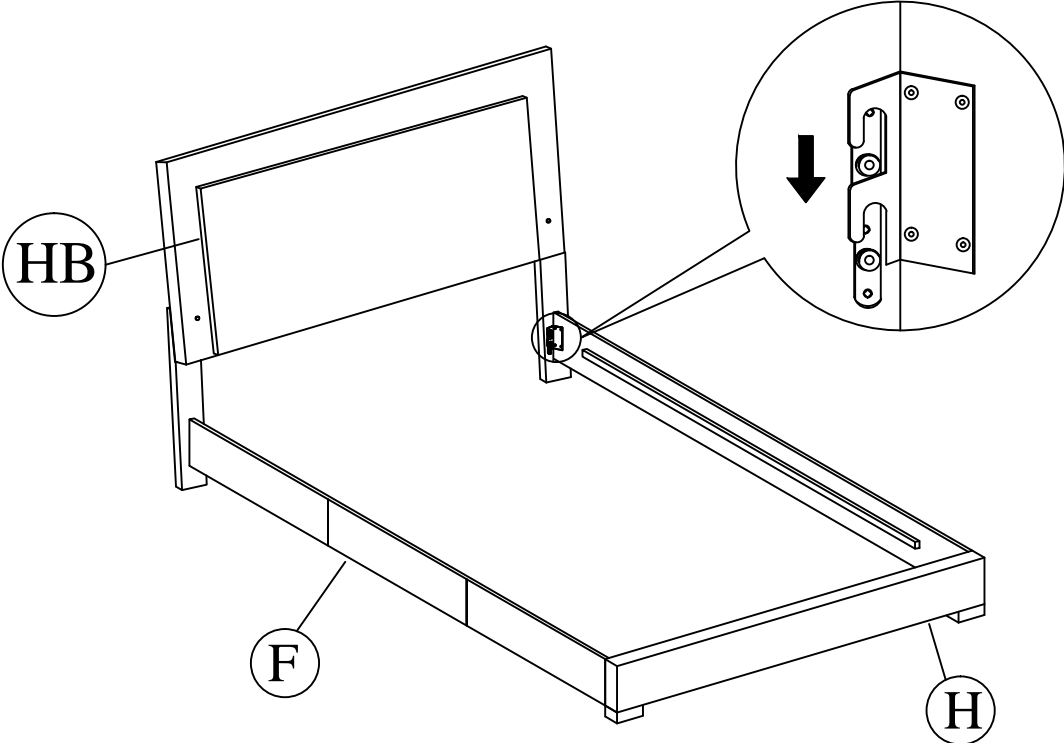

STEP 5

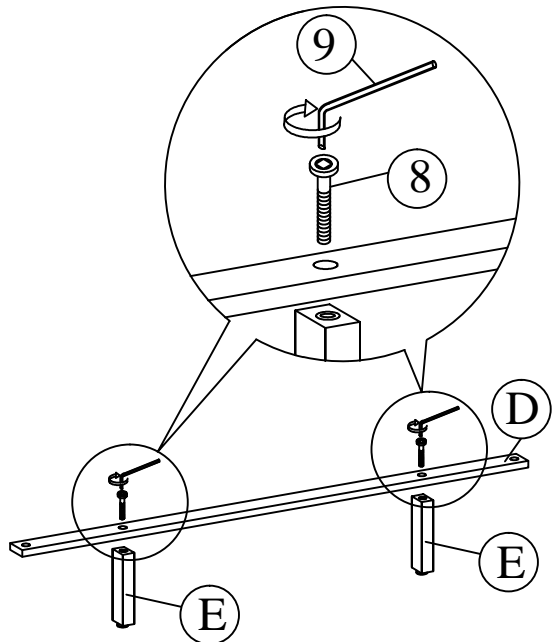

STEP 6

