

ASSEMBLY INSTRUCTIONS

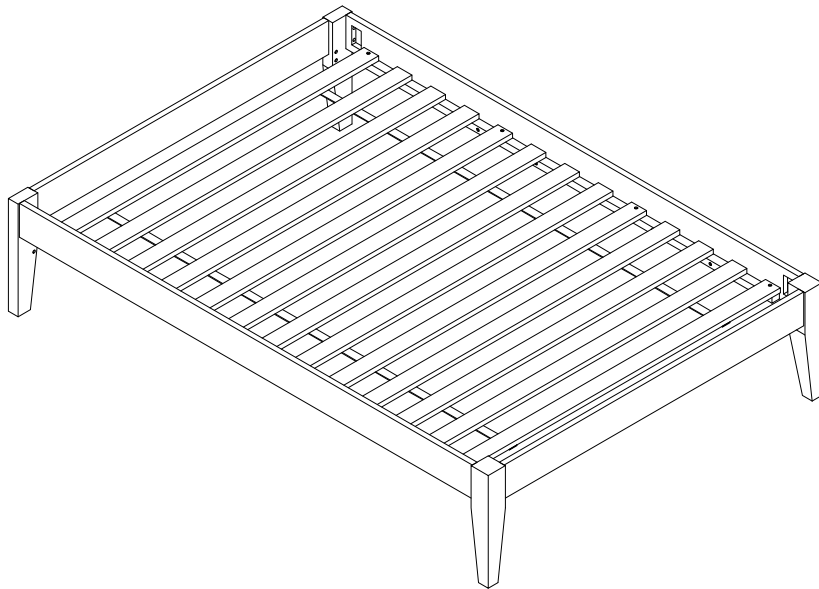

Twin Universal Platform Bed

ASSEMBLY INSTRUCTIONS

ASSEMBLY TIPS:

1. Remove hardware from box and sort by size.
2. Please check to see that all hardware and parts are present prior to start of assembly.
3. Please follow attached instructions in the same sequence as numbered to assure fast & easy assembly.



WARNING!

1. Don't attempt to repair or modify parts that are broken or defective. Please contact the store immediately.
2. This product is for home use only and not intended for commercial establishments.

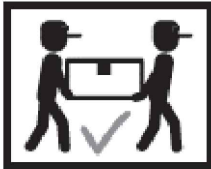

ASSEMBLY TIME

10 MINUTES

PARTS IDENTIFICATION

B1 (BOX 1)

A HEADBOARD

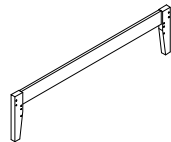

1PC

B FOOTBOARD

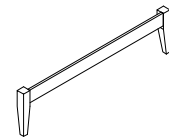

1PC

B2 (BOX 2)

C BED RAIL

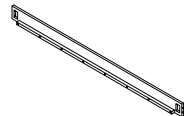

2PCS

**D ROLL SLAT
(13PCS)**



1SET

HARDWARE IDENTIFICATION

Z-B2 (BOX2) - HARDWARE PACK IS LOCATED

**1 THREADED BOLT
(5/16 x 90mm - RBW)**

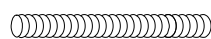

8PCS

**4 WRENCH
(12mm - RBW)**



1PC

**2 HEX NUT
(5/16 x 12mm - RBW)**



8PCS

**5 FLAT HEAD SCREW
(4 x 30mm - RBW)**



8PCS

**3 FLAT WASHER
(8 x 16 x 1.5mm - RBW)**



8PCS

NOTE:

Phillips head screw driver is required in the assembly process; however, manufacturer does not provide this item.

ASSEMBLY INSTRUCTIONS

STEP 1

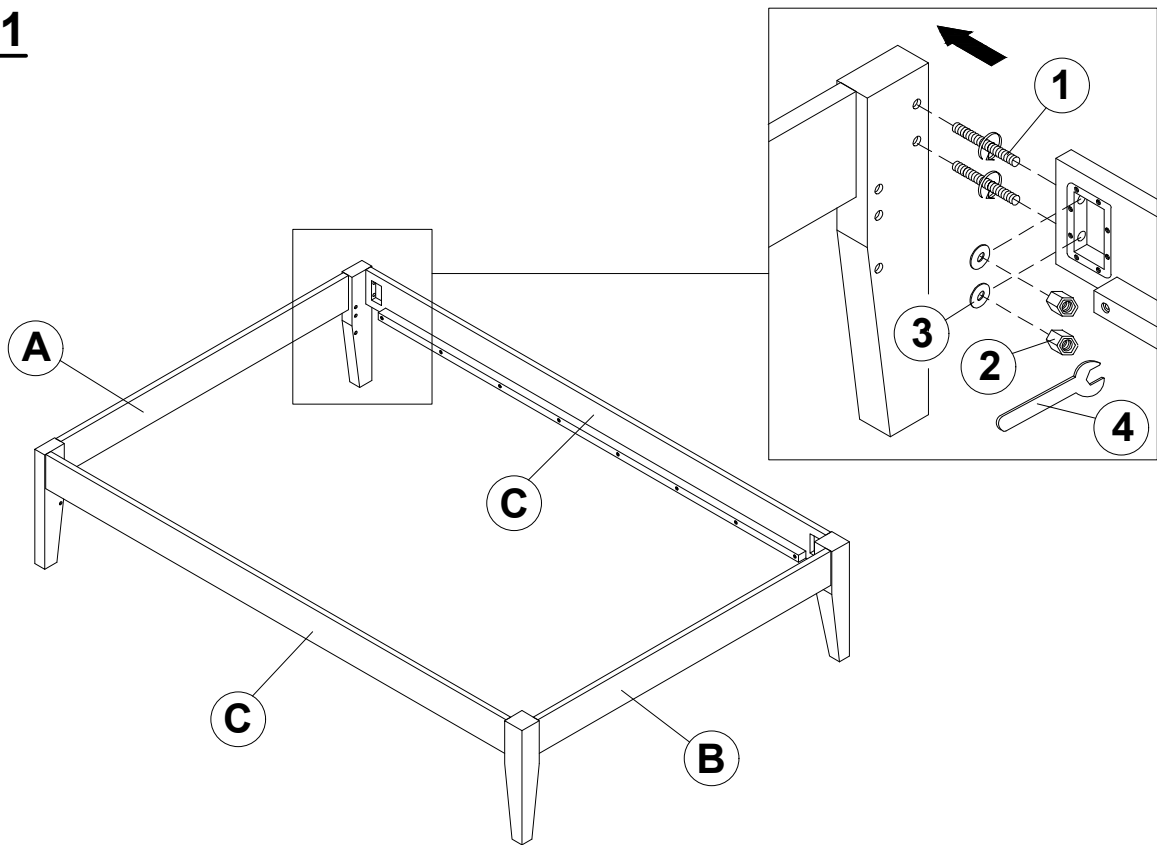

STEP 2

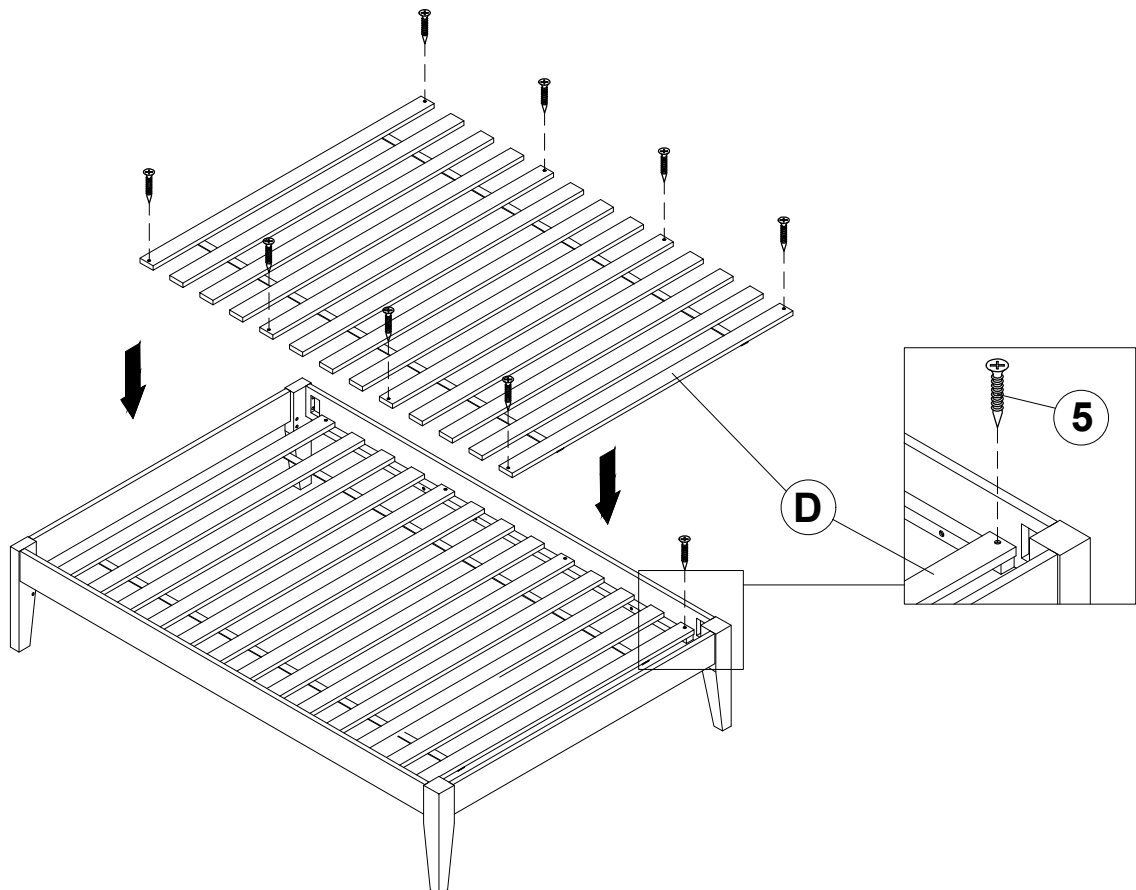

ASSEMBLY INSTRUCTIONS

STEP 3

COMPLETE

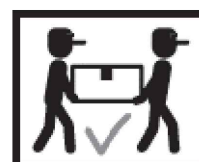
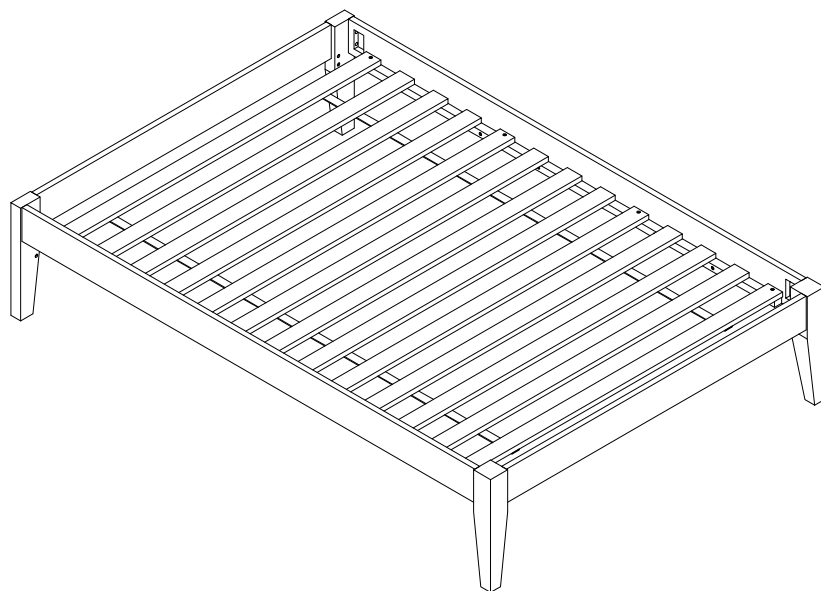

ASSEMBLY INSTRUCTIONS

INNER SIZE: 41.25" X 76.00"

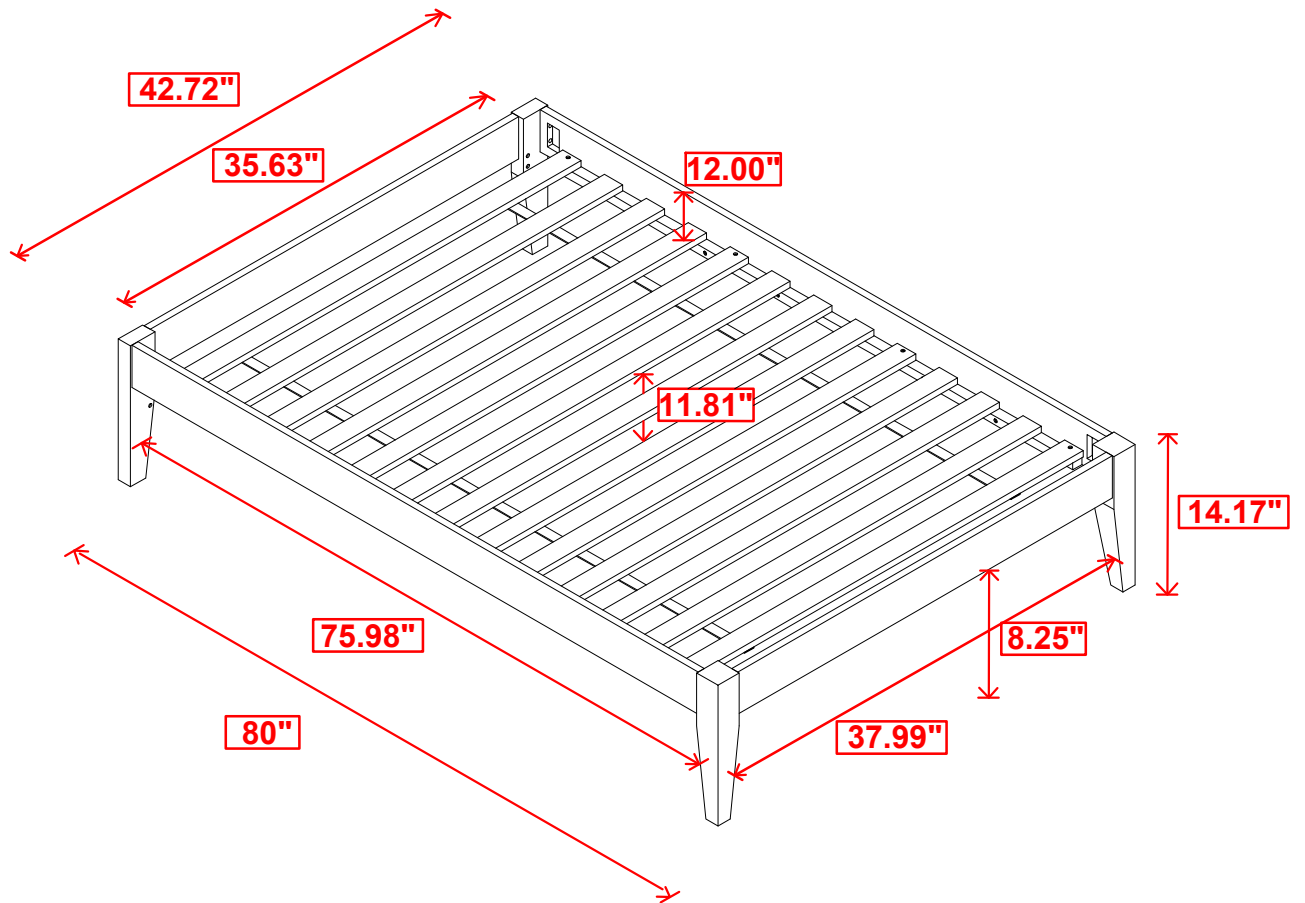

Note: Dimension tolerance $\pm 5\%$