



furnishing better
lives together[®]

WWW.JOFRAN.COM

ASSEMBLY INSTRUCTIONS & PARTS IDENTIFICATION MODEL # 2546-380KD WESTPORT NAVY DOWELBACK CHAIR

Thank you for purchasing this quality product. Be sure to check all packing material carefully for small parts that may have come loose inside the carton during shipment.

Hardware kit (2546-380KD46)			
No		Description	Q'Ty
A		Hexa Nut Ø7.9x0.794	8 pcs
B		Lock Washer Ø8.2	8 pcs
C		Flat Washer Ø8.2	8 pcs
D		Bolt Ø8.3x0.794 x 70mm(L)	4 pcs
E		Allen Key	1 pc
F		Key Wrench	1 pc

Key Parts			
No	Code	Description	Q'Ty
1	2546-380KDP40	Chair Back	1 pc
2	2546-380KDP41	Complete Seat	1 pc
3	2546-380KDP42	Front Leg	2 pcs
4	2546-380KDP43	Back Leg	2 pcs
5	2546P01F	Floor glide	4 pcs

STEP 1

- Carefully lay the chair back flat on a smooth surface to prevent scratches.
- Attach the complete seat to the chair back by inserting a Bolt (D) into each hole on the back rail of the seat, aligning with the corners of the complete seat. (See Detail A.)
- Tighten the bolts using the provided Allen Key (E) by turning clockwise until secure.

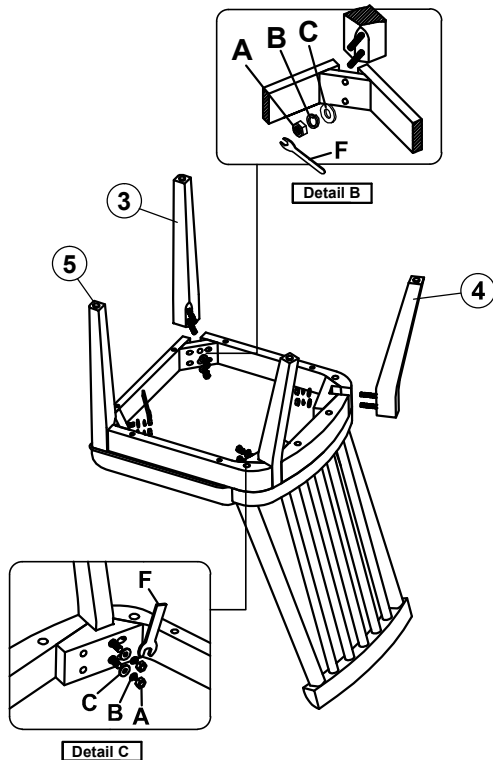
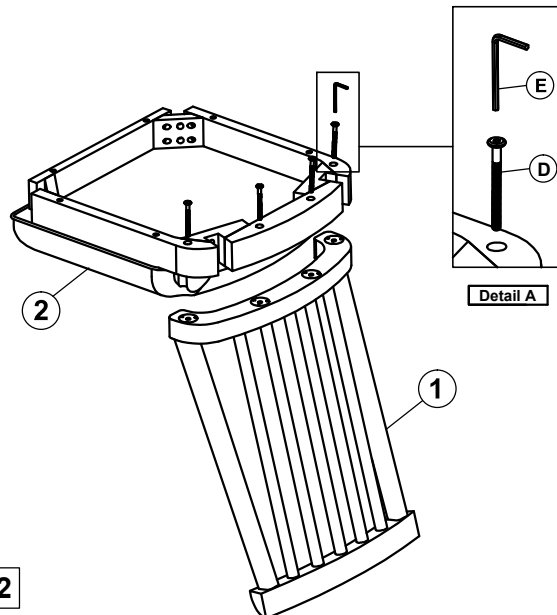

STEP 2

Carefully turn the Chair upside down and attach each Leg to the front and back corners of the Complete Seat.

Place a Flat Washer (C), a Lock Washer (B), and a Nut (A) onto each bolt using the provided Key Wrench (F).

Do not fully tighten the Nuts at this stage until all parts are in position. (See Details B & C.)

Be sure to tighten all screws and nuts prior to using the Chair.

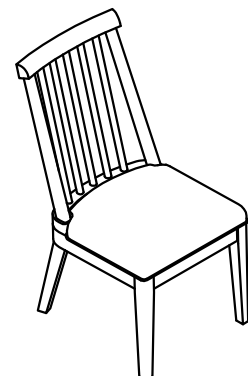

MADE IN VIETNAM