

Assembly Instruction Sheet

SKU#5081-LR-220 - WINSTON ROUND END TABLE

Thank you for your purchase.



Before discarding packaging material be sure to locate all parts including the necessary hardware and tools listed in the instruction sheet below.

Please read all instructions before unpacking assembly parts.

Also, exposed staples can cause injury, for your protection carefully remove any staples used in the packaging.

Parts/Hardware list:

NO#	DESCRIPTION		QUANTITY
A	BOLT	1/4"x 3/4"	8 PCS
B	BOLT	1/4"x1 9/16"	8 PCS
C	SPRING WASHER	1/4"	16 PCS
D	FLAT WASHER	1/4"x13x1mm	16 PCS
E	METAL BRACKET	32*18*21*2mm	4 PC
F	ALLEN KEY	M4x59mm	1 PC

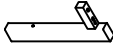
NO#	DESCRIPTION		QUANTITY
1	TOP PANEL		1 PC
2	SHEFL PANEL		1 PC
3	LEGS FRAME		4 PC

Step 1

Diagram assembly

Note: The bolts do not too tightened.

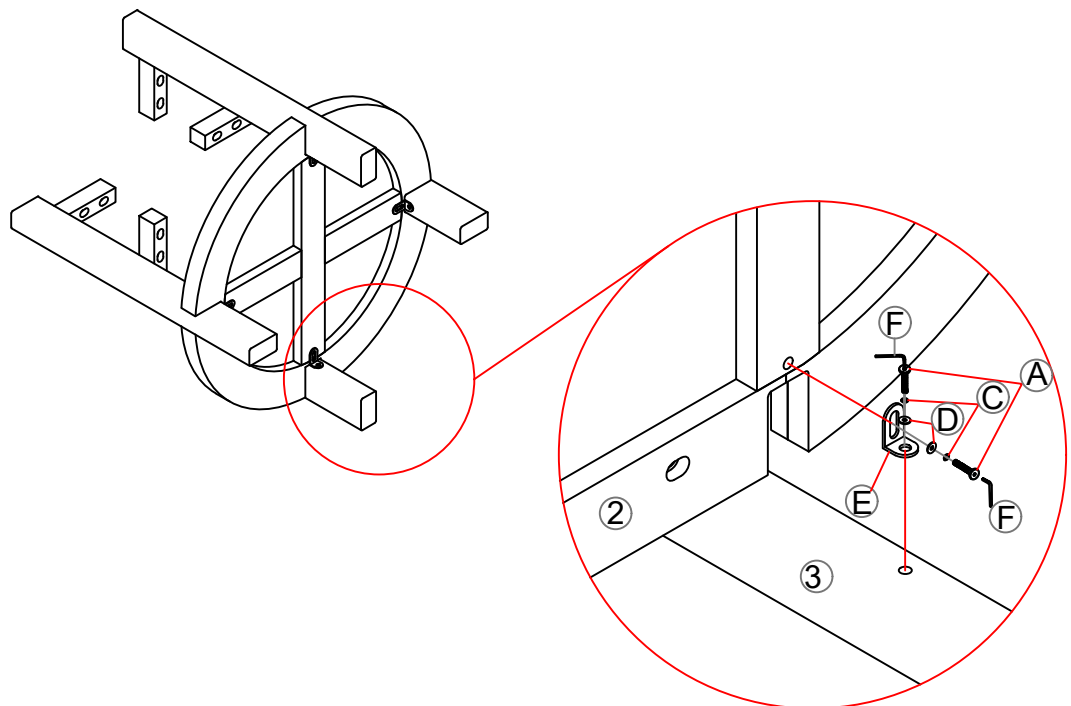

Customer Help Line
1-276-629-3341 EXT 3206

Step 2

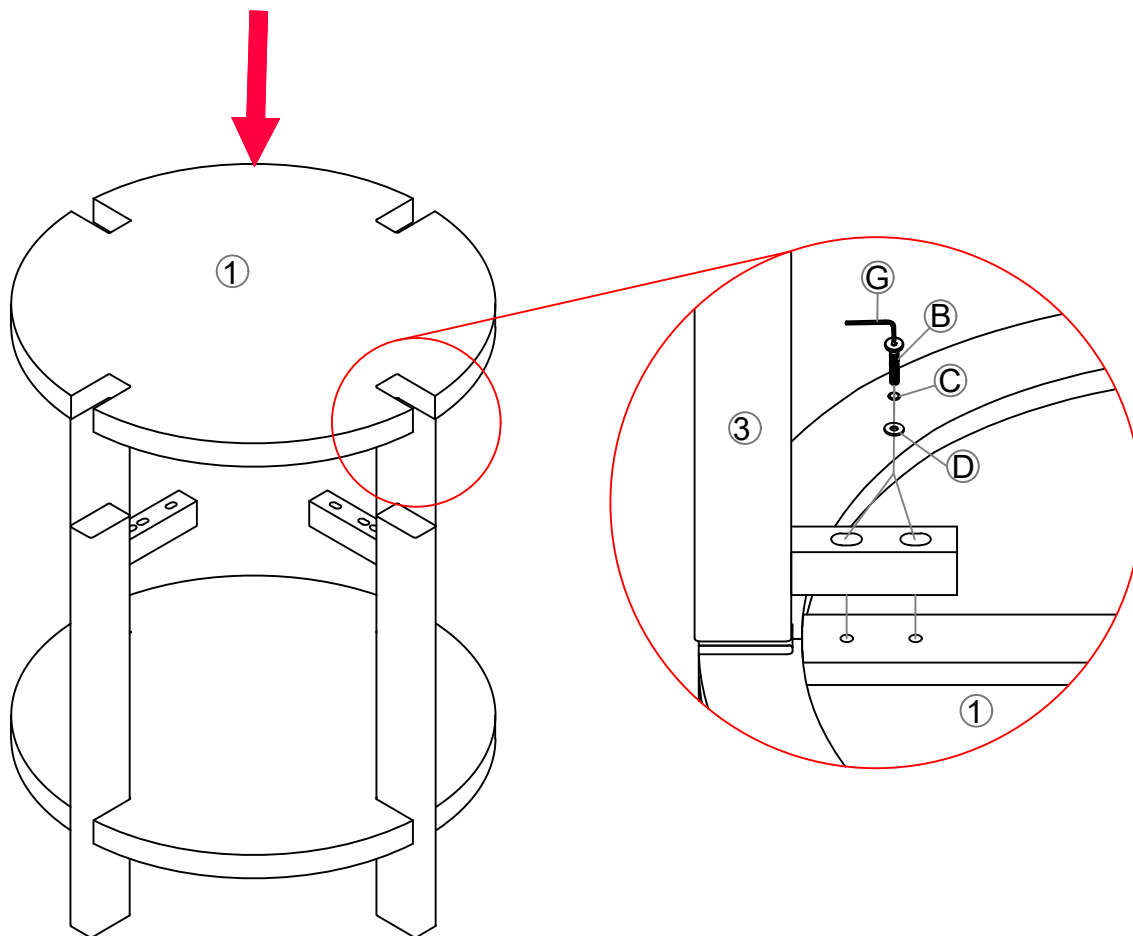

Note: Finish, Tighten all bolts after adjusted between the legs and the table top.

