



# INSTRUCTION MANUAL



# Assembly Guide







Congratulations, you are now the owner of a brand new ergonomic chair!

To best enjoy comfort of the chair, you have to put it together first! This assembly guide will take you through the assembly process. To make sure the assembly goes well, please follow the instructions, and especially the important safety information. It is possible to assemble the chair on your own, but it is recommended to have a second person to make it easier and safer.

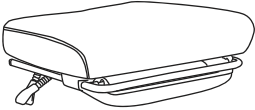
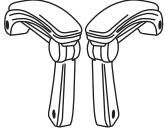
Please check if there are any missing parts from the package before starting. If there is any issue, please don't hesitate to drop us an email and we'll help you out ASAP. If you run into any difficulty when assembling the chair, remember to check out the assembly video to see if you've missed anything. If you're unable to resolve the problem, just send us an email and our support team will assist you.

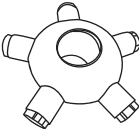

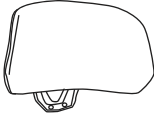



# Package List

Without further ado, we kindly suggest you to list all parts needed for the chair first.

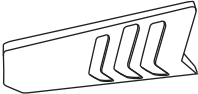
<p><b>(A)X1</b></p> 	<p><b>(B)X1</b></p> 	<p><b>(C)X1Lx1R</b></p> 
<p><b>(D)X1</b></p> 	<p><b>(E)X1</b></p> 	<p><b>(F)X5</b></p> 
<p><b>(G)X5</b></p> 	<p><b>(H)X1</b></p> 	<p><b>(I)X1</b></p> 

# Package List

Without further ado, we kindly suggest you to list all parts needed for the chair first.

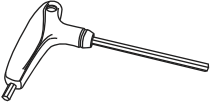
<p><b>(J)X1</b></p> 	<p><b>(K)X1</b></p> 	<p><b>(L)X1</b></p> 
<p><b>(M)X10 M6x14</b></p> 	<p><b>(N)X2 M8x20</b></p> 	<p><b>(O)X6 M6x22</b></p> 
<p><b>(P)X2 M6x30</b></p> 	<p><b>(Q)X2 M8x35</b></p> 	<p><b>(R)X1</b></p> 

# Assembly Instruction

- **Step 1:**

Turn the Base (E) upside down, insert Base Legs (F) one by one to the Base (E), then tighten them with 10 Screws (M) by Allen Wrench (R).

\*Note: Tighten all Screws completely.

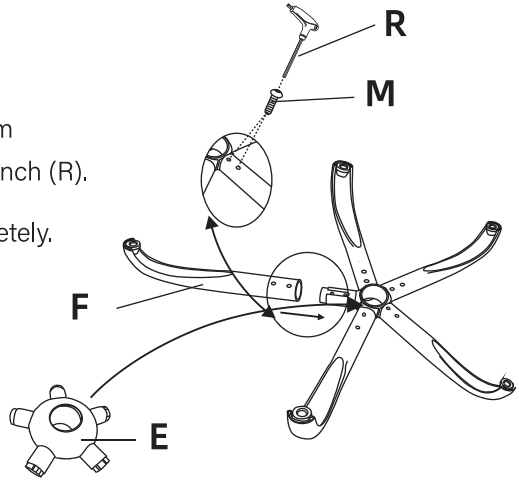

- **Step 2:**

Insert Casters (G) into the Base Legs (F). Then insert Gas Lift (D) into the hole in the center of the Base (E).

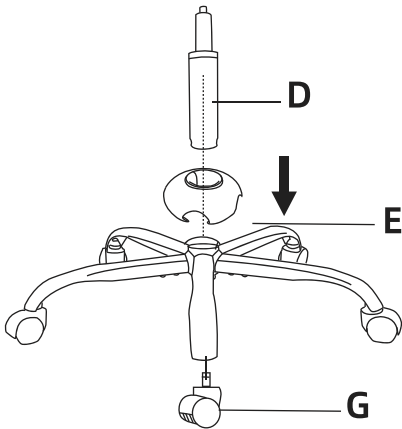

# Assembly Instruction

- **Step 3:**

Position the Chair Seat (B) upright with the Mechanism facing down. Insert the Gas Lift (D) into the center hole of the Seat Mechanism and press down until fully engaged.

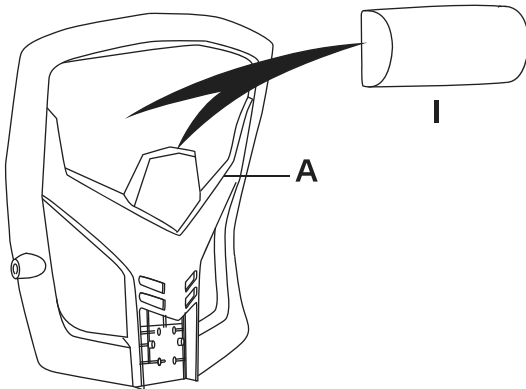
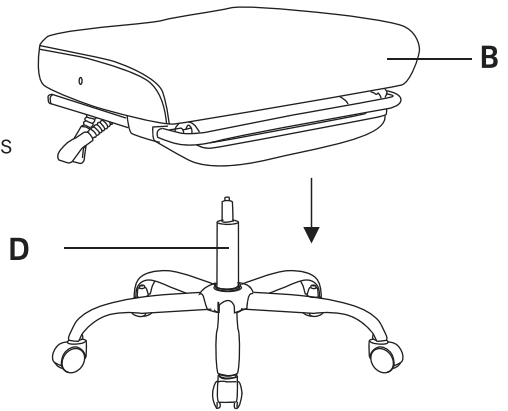

- **Step 4:**

Take the Lumbar Pillow (I) from the back frame of Chair Back (A).

# Assembly Instruction

## • Step 5:

Attach the Back Bar (J) to the Chair Back (A) with 4 Bolts (O) by Allen Wrench (R).

\*Note:  
Tighten all Bolts completely.

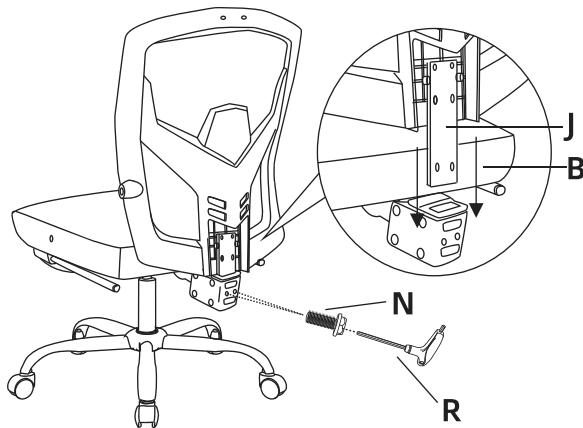
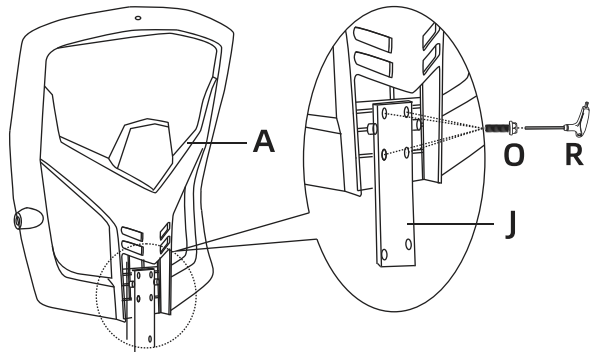

## • Step 6:

Insert the Back Bar (J) into the hole at the back of the Chair Seat (B), the tighten them with 2 Bolts (N) by Allen Wrench (R).

\*Note:  
Tighten all Bolts completely.

# Assembly Instruction

- **Step 7:**

Attach the Back Bar Cover (K) to the Chair Back (A) by pushing the buckle into the slot.

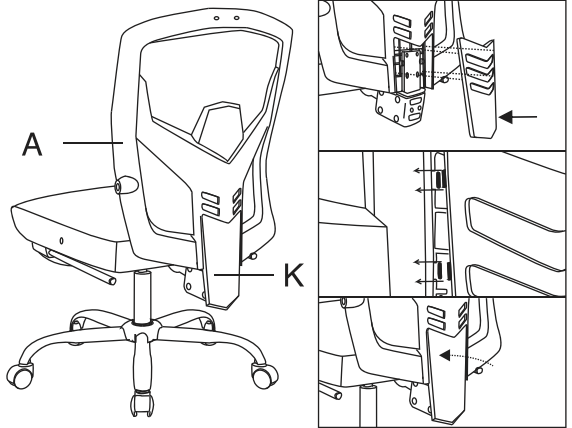

- **Step 8 :** Attached the Armrests (C) to the Chair Back (A) with 2 Screws (P) and to the Chair Seat (B) with 2 Screws (Q) by Allen Wrench (R).  
\*Note: Tighten all screws completely.

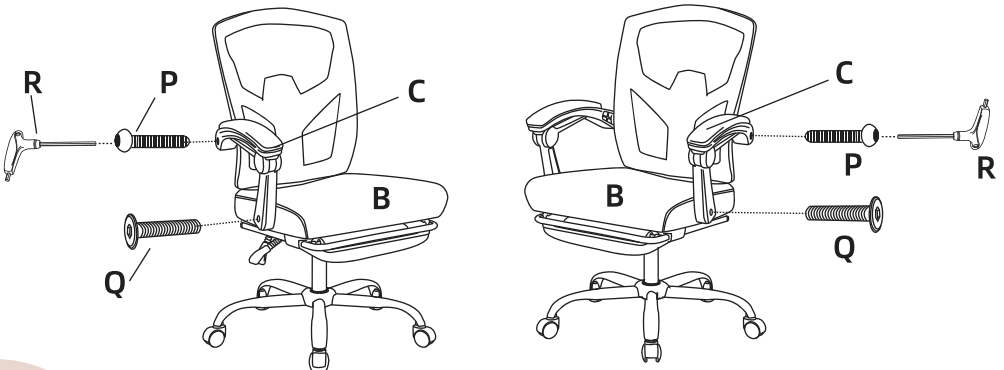

# Assembly Instruction

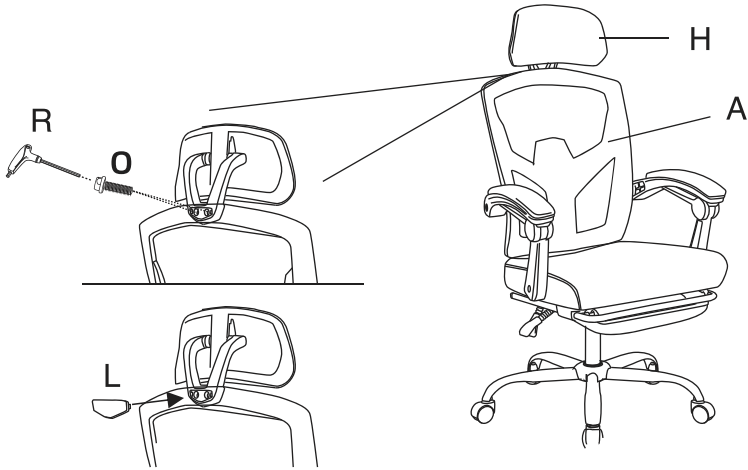

- **Step 9:**

Attached the Headrest (H) to the Chair Back (A) with 2 Bolts (O) by Allen Wrench (R). Then, attached the Plastic Cover (L) to the hole of the Headrest (H).

\*Note: Tighten all Bolts completely.

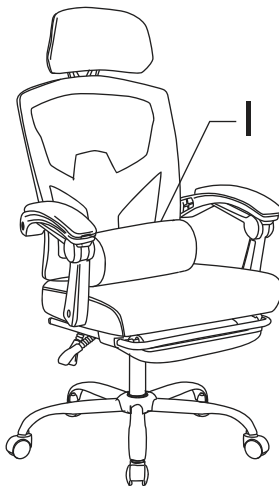

- **Step 10:**

Put the Lumbar Pillow (I) on the assembled chair.

# Instructions For Use

## 1. Seat Height

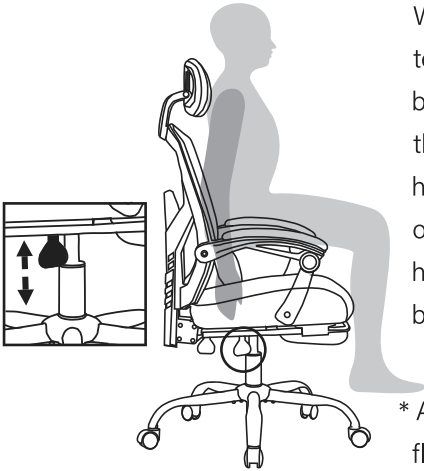

While seated, reach the right side of the chair to find the handle at front. Lift it and raise your body up slightly to allow the chair to rise to the desired height. To lower the seat, lift the handle while applying more weight downward on the seat. The chair will descend until the handle is released or the chair reaches the bottom position.

\* At the proper height, your feet should rest flat on the floor.

## 2. Tilt Adjustment

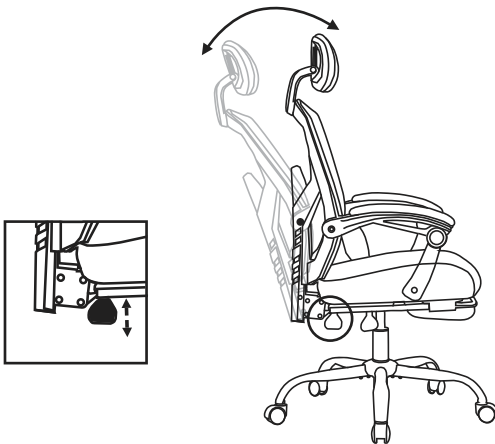

While seated, reach the right side of the chair to find the handle at back. Lift it up to horizontal direction and lean your body back slowly, push the handle down until the desired tilt angle is reached. Lift the handle up and move your body away from the chair back slowly to restore the backrest to the vertical angle.

# Instructions For Use

## 3. Headrest Adjustment

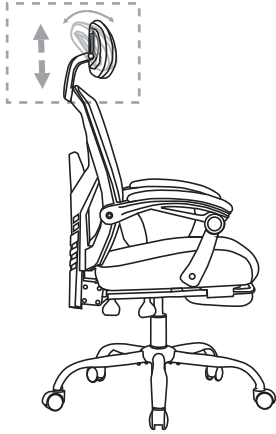

Move the headrest up/down to adjust the height to the desired height. Angle the headrest up/down to the desired position.

## 4. Footrest Adjustment

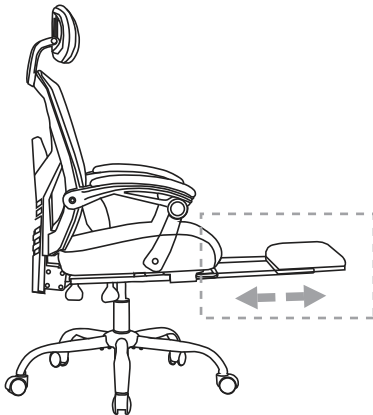

Reach the footrest under the chair seat, pull it out for extended use. Push it back to store away.

# Safety And Maintenance

- Do not stand on the chair, Do not use the chair as stepladder.
- Use this product for seating one person at a time.
- Do not use the chair unless all bolts and screws are firmly secured.
- Avoid contact with sharp objects to prevent puncturing the fabric.
- Every 6 months, check all bolts and screws to ensure they are tight.
- To clean, spot clean only using a damp towel and mild cleaner, first test on a small, unseen area of fabric.
- Chair weight limit not to exceed 275 lbs.

## Safety Information



Sit in the center of the chair, with your back to the backrest



Do not sit at the front edge of the chair



Do not stand on the chair



Do not use the chair with more than one person



Do not push the chair around when a person is sitting in it



Do not push down on the backrest when a person is reclined



Do not place all your weight on only the backrest

# Limited Warranty

The producer promises to repair or replace any chair that is found to be defective in material or workmanship within one(1) and year from the date of original purchase so long as you, the original purchaser, still owns it. This is your sole and exclusive remedy. This warranty is subject to the provisions below.

## EXCLUSIONS:

This warranty does not apply and no other warranty applies to:

- Normal wear and tear, which are to be expected over the course of ownership.
- Misuse, abuse or excessive use of the product.
- Modifications or attachments to the product that are not approved by the manufacturer.
- Products that were not installed, used, or maintained in accordance with product instructions and warnings.
- Products used for rental or commercial purposes.
- Damage caused by the carrier in-transit is handled under separate terms.

## SEATING USAGE:

Normal use for seating is identified as the equivalent of a single shift, forty- (40) hour workweek. To the extent that a seating product is used in a manner exceeding this, the applicable warranty period will be reduced in a pro-rata manner. Some retailers might have custom models imported direct from the factory and therefore are not supported by our local service team because we don't have the correct parts, please contact your retailer directly for support. If you have any questions about that we will be happy to assist and identify those items.

# Limited Warranty

## RETURN POLICY:

We adopt a 30 days return policy which means that all products purchased on this website may be returned to us within the timeframe. You need to contact us within 30 days after the product(s) came into your possession and the product(s) must be returned to us without any undue delays. Returned products must be returned in the same condition as they were sent and they must be sent in its original packaging. If the product is not faulty, (i.e. if you changed your mind or if you are unhappy with the product for some other reason), the cost of shipping will all on you. And it is your responsibility that the package arrives safely to us so we recommend that you use a courier service where it is possible to track the shipment. If the product is faulty when you receive it please contact us and we will help you out (see more information under Manufacturer Warranty). We reserve the right to give a partial refund in cases when the product(s) is not in an unused condition, is damaged or have missing parts not due to our error.

## HOW RETURNS WORK:

Contact us through the contact form on our website and attach the invoice to the message as a proof of purchase. And please also write the reason for return. We will then get back to you as soon as possible with information on where to send the product(s). As soon as we have received the product(s) and made an inspection we will inform you of our decision. If a refund is approved we will automatically credit the purchase to your credit card or original method of payment. If the product(s) is damaged, not in its original condition or missing parts we will inform you if you are eligible for a partial refund. This is decided from case to case depending on the severity of the damages or what parts are missing.