

Model : W5100S

User Manual

- Thank you for choosing our products. Please read the instructions carefully before installation and keep it available for future maintenance or reference.

Content

Installation

Safety instructions	01
List of materials	03
Technical drawings	04
Parts identification	05
Toilet Installation	06
Before Installation	08

Maintenance

Daily maintenance	09
1.Main unit care and maintenance	
2.Maintenance of filter net	
Emergency troubleshooting	10
1.Electricity and water supply cut-off	
2.Replacement of battery	
3.When the product is left unused for long time	

Others



Technical specification	11
The illustration of Main Unit Buttons	11
Warranty Terms	12

Safety instructions



Please read the instructions carefully before installation and keep it available for future maintenance or reference.





Failure to follow these instructions can cause body injury and property damage.

Symbol Illustration

 Warning	Indicates that failure to follow the instruction may cause serious injury or fatality.
 Caution	Indicates that failure to follow the instruction may cause body injury or property damage.

Symbol Illustration

Symbol	Indication
	Prohibited activities
	Mandatory activities

 Warning	
	Do not throw cigarettes and other burning stuff into toilet, otherwise it might cause malfunction.
	<p>Do NOT disassemble, repair or modify this product by yourself, otherwise it may cause fire or malfunction.</p> <p>Do NOT pour water or detergent on the main unit or battery box plug, otherwise it may cause fire or electric shock.</p> <p>Do NOT touch the battery box plug with wet hands, otherwise it may cause malfunction.</p> <p>This product is factory equipped with a specific battery device. Do NOT use any battery device other than the factory equipped battery device, otherwise it may cause fire or malfunction.</p> <p>If the electric wire of battery box is damaged, it must be replaced by the manufacturer, its service center or equivalent specialist to avoid malfunction.</p> <p>This product is an electric appliance, avoid direct contact with water or other liquids.</p> <p>Do not position the product on its side or upside down while making electrical connections with the battery box, otherwise it may cause fire or burning.</p>
 Mandatory activities	Do not install or use the product in wet or damp locations such as in a steam room.

 Warning

 Mandatory activities	<p>Only use the factory equipped battery box and 1.5V “AA” alkaline battery.</p> <p>When moving the product from a cold or humid place to a warm room, please wait for 2 hours before use - to volatilize the condensed water inside the product. Otherwise it may cause short-circuiting.</p>
---	--

 Caution

	<p>Do not place or store product where it can fall or be pulled into a tub or sink.</p> <p>Do not place in water or other liquid.</p> <p>Do NOT touch the product that has fallen into water. Unplug the battery box immediately</p> <p>Do not stand on the toilet. Do not hit the ceramic. A heavy impact on ceramic leads to damage and leakage.</p> <p>Never embed ceramic toilet base in cementitious material (such as cement mortar). It may lead to expansion crack.</p> <p>Do not stand on toilet bowl, seat and cover.</p> <p>Do not use varnish thinners, gasoline, liquid chemicals, detergents, insecticides, toilet cleaners and scrubbing brush to clean the product.</p> <p>Only use tap water or potable water.</p> <p>Exposure to direct sunlight is prohibited.</p> <p>This product is equipped with soft-closing seat and cover. Heavy pressing or pushing may damage the soft-closing damper.</p> <p>Do not connect the water supply hose to hot water valve. Make sure inlet water temperature at 5-35°C , otherwise the built-in module will be damaged.</p> <p>Do not lean against the seat cover when using the product to avoid damage.</p> <p>Do not flush newspaper, diapers, sanitary napkins and other items into the toilet which may result in toilet clogging.</p> <p>If this product is malfunctioning, stop using immediately, unplug the battery box, turn off water supply, and contact the service provider.</p>
--	--

 Mandatory activities	<p>Before installation, disassembly, repair and maintenance of the product, the power plug must be unplugged and the water supply valve must be closed.</p> <p>Do not use in an environment below 0 °C.</p> <p>If this product will not be used for an extended period of time (over 3 days), it is recommended to unplug the battery box, remove batteries, turn off water supply, and drain water in the product.</p> <p>When using electrical products, especially when children are present, basic safety precautions should always be followed, including the following:</p> <ol style="list-style-type: none">1. This product is not intended for children (without proper adult supervision).2. This product is not intended for individuals with reduced physical, sensory, or mental capabilities. <p>To prevent damage caused by freezing, please implement warmth measures to increase the temperature of the toilet.</p>
---	---

List of materials

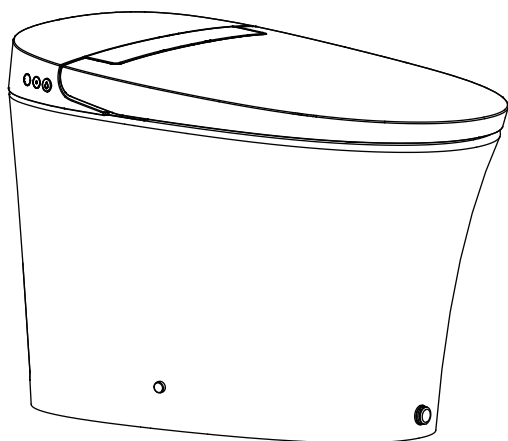

Main Unit

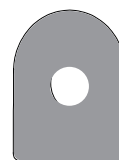

Installation Cardboard

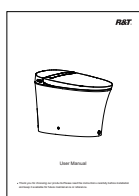

Installation Manual

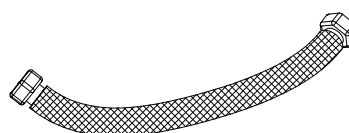

Braided hose

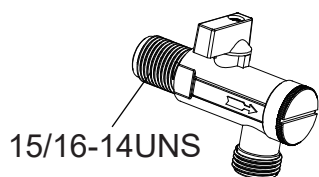

Angle Valve option 1

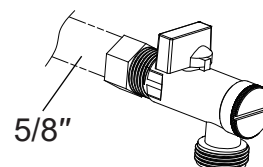

Angle Valve option 2



Sealing Flange

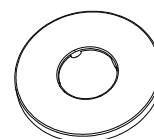

Flange

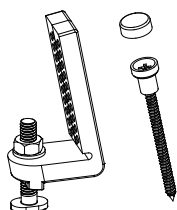

Mounting accessory kit

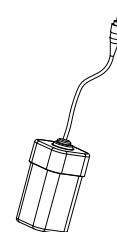

Battery box

Technical drawing

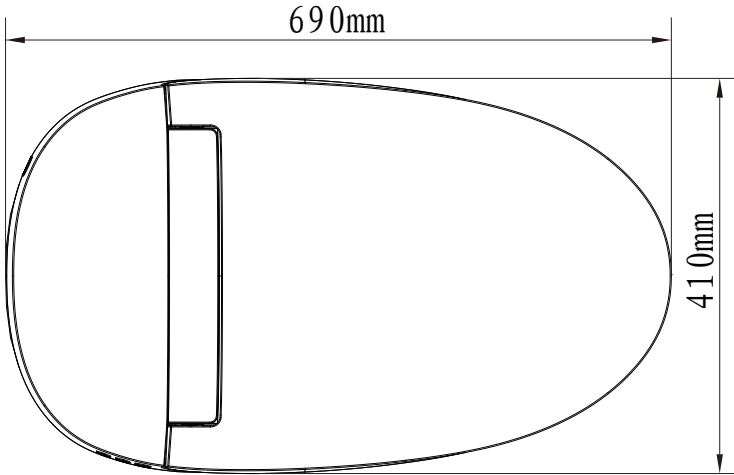
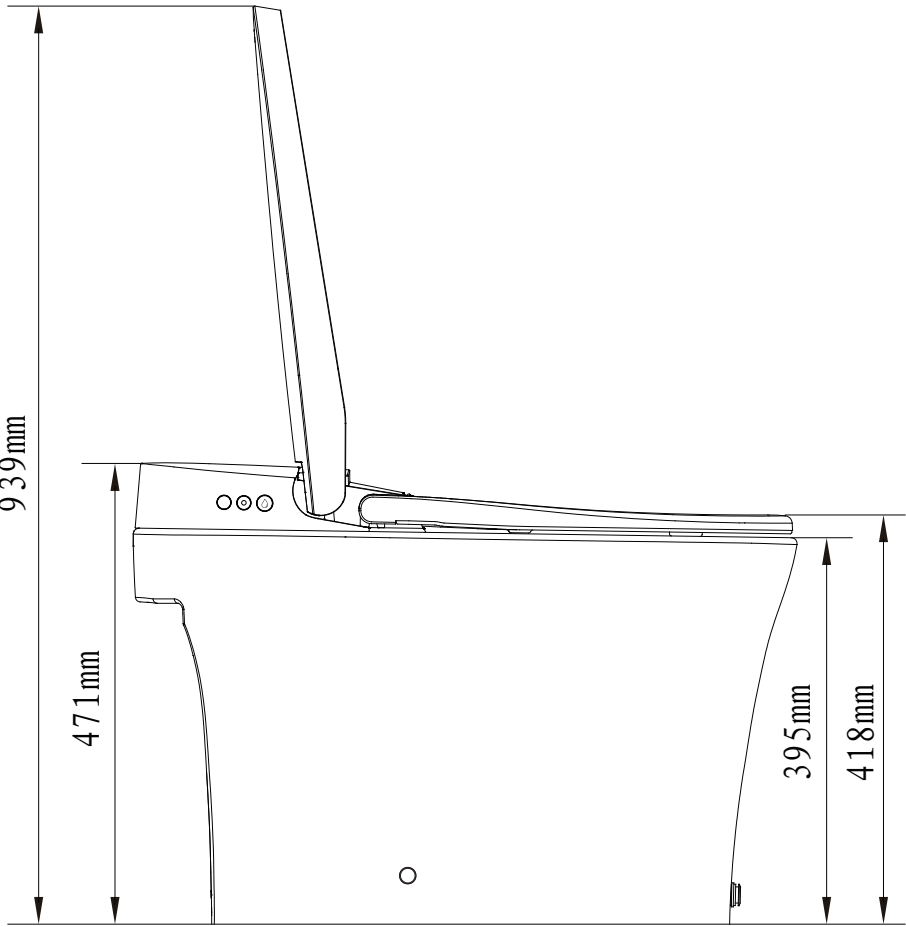

The product drawings are for reference only, and the company reserves the right to modify the appearance of the product without notice.

Parts identification

Left side

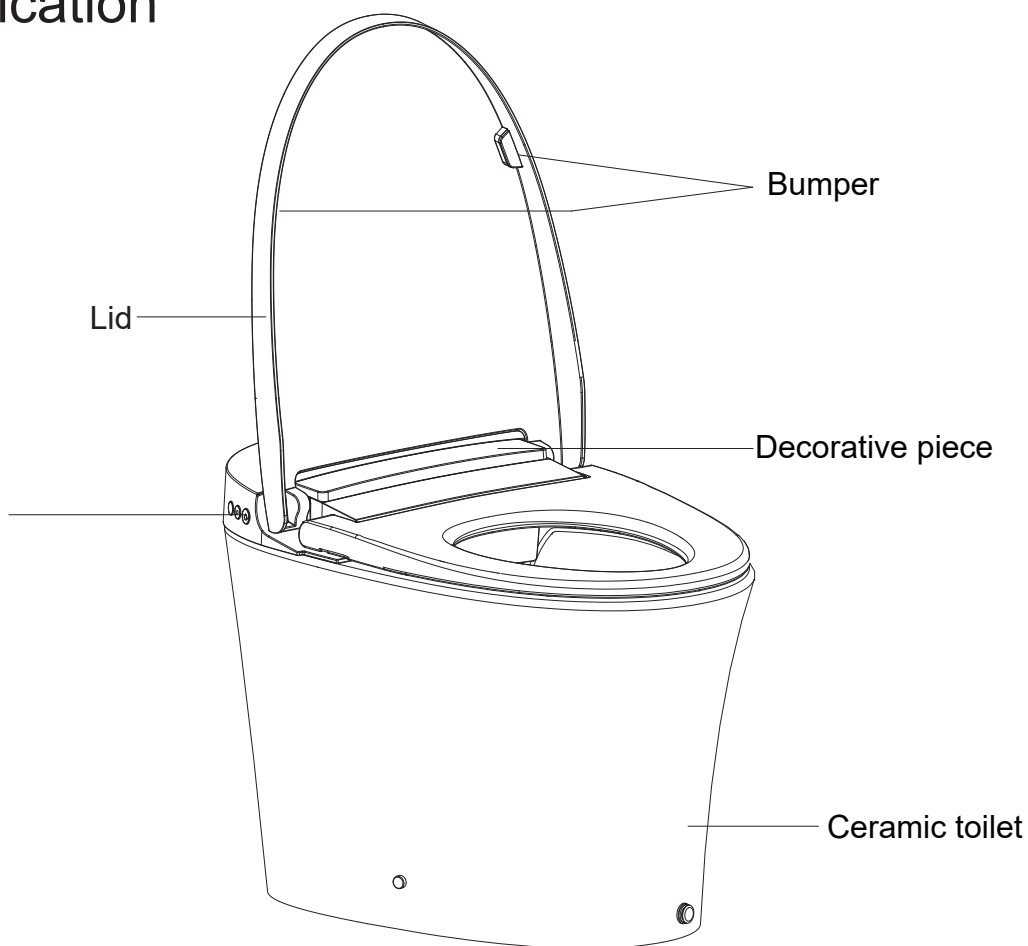
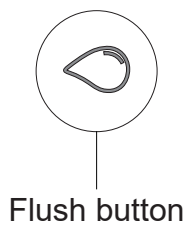

Right side

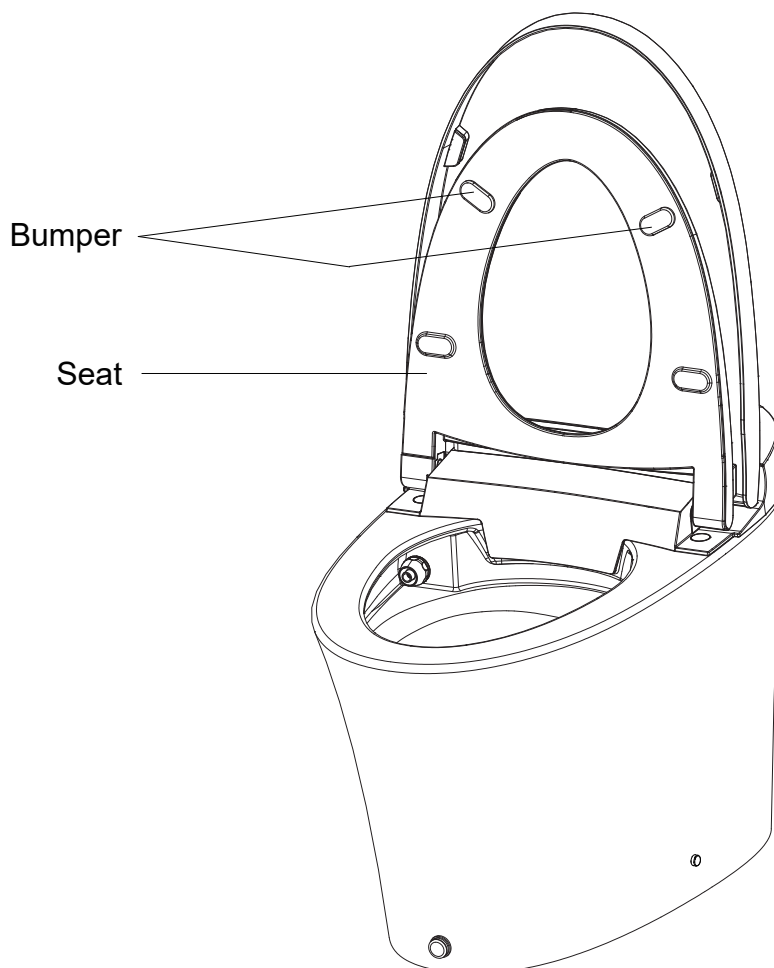

Installation of ceramic toilet

⚠️ Precaution before installing

- Minimum dynamic working water pressure: 0.09MPa or more (3.96Gal/min(15L/min) or more), failure to meet this pressure will not achieve the best flushing effect.

Remark: Apply the methods below if you don't have water pressure testing device.

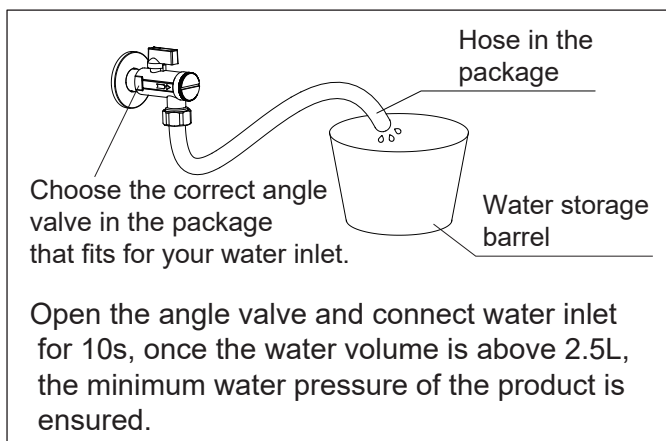

1. Installation of mating angle valve

- Draw drain outlet centerline on the floor, Install angle valve at proper position on wall according to dimension of toilet.

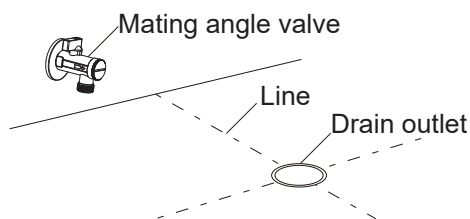

2. Cardboard installation

- Align cardboard with the centerline of drain outlet;
- Draw contour line according to cardboard;

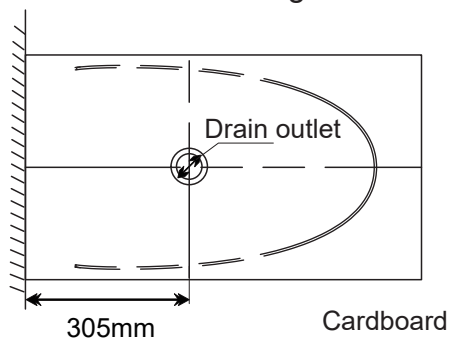

3.Hose

- Connect the water inlet and angle valve of the toilet with the matching hose and tighten it

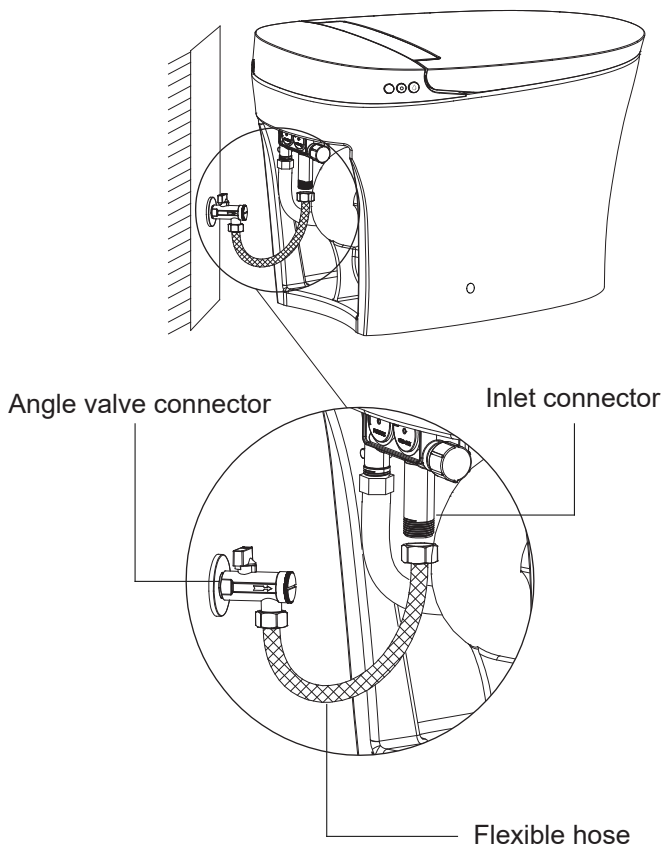

4.Mounting bracket installation

- Assemble the mounting bracket with bolts and then install them to the pre-installed flange plate on the ground and lock tight with nuts.

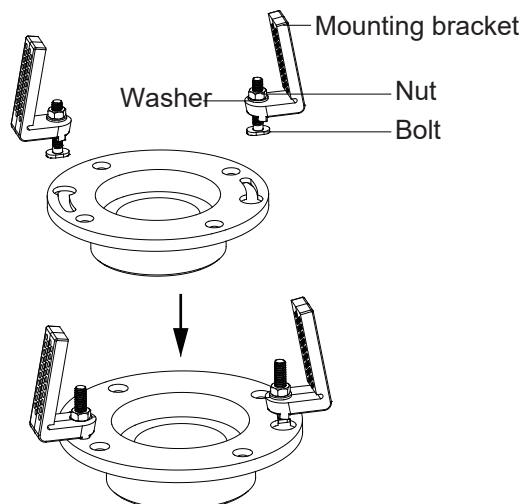

5. Ceramic toilet installation

- Install sealing flange into drain outlet;
Install ceramic toilet on corresponding position according to contour line.

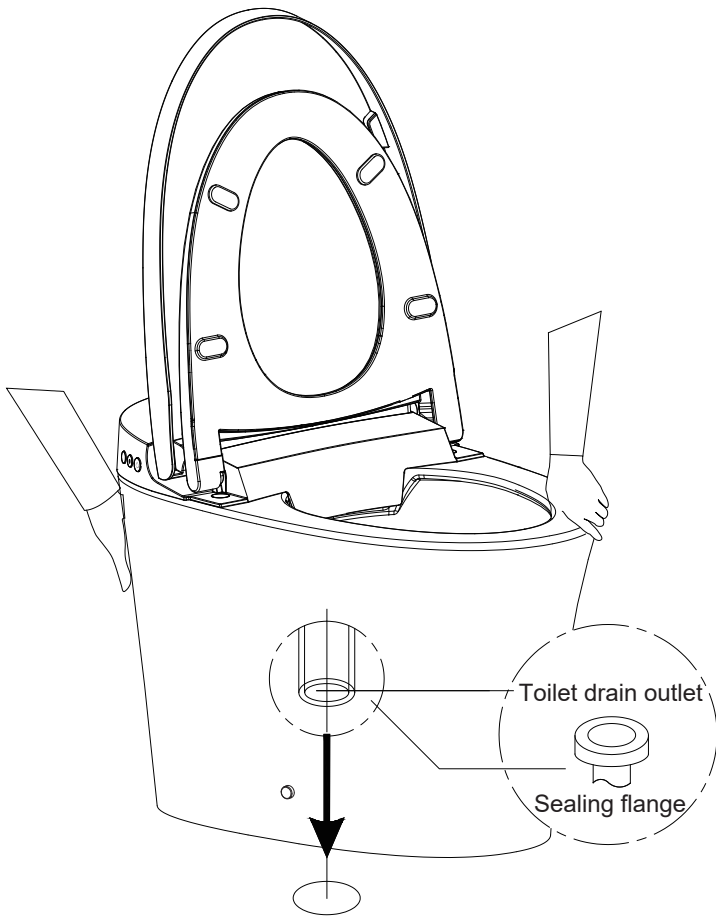

6. Screw installation

- Put the screw through the fixing sleeve and then install it through the holes (on both sides of the toilet ceramic) to the mounting bracket on the ground, and lock tight with a tool;
- Put the decorative cap on the fixing sleeve.

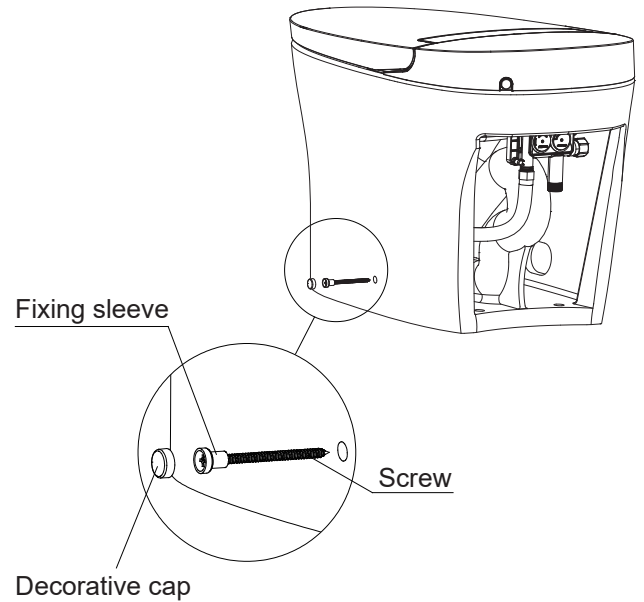

7. Glass cement application

- Apply high quality mildew glass glue around the lower edge of the toilet.

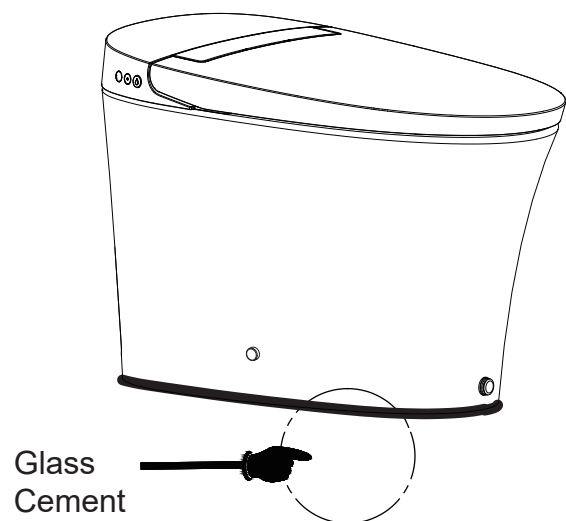

Tips:

- Please clean the drain outlet;
- Please make sure ceramic toilet outlet sits perfectly on drain outlet.

Before Installation

1. Turn on the angle valve

Check thread connection, make sure no leakage is found, unscrew angle valve anticlockwise to maximum opening.
(Tips: When opening for the first time, the angle valve handle has a larger torque)

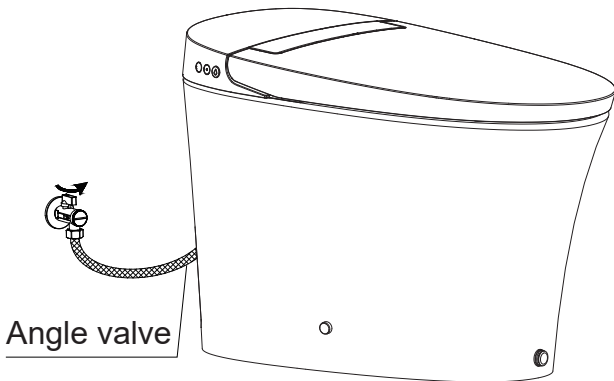



2. Power Connection

Take out the battery box from the accessory kit and install 4pcs 1.5V "AA" alkaline batteries. Plug the DC plug of battery box into the DC socket of toilet and then stick the battery box to the Velcro on the bottom of the toilet.

Notes:

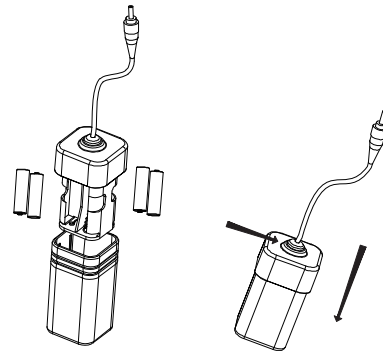
1. Must be 1.5V "AA" alkaline battery;
2. Batteries of different brands, new and used batteries can not be used together.
3. Battery life will be significantly reduced when using non-alkaline batteries;
4. When installing the inner box components, follow the installation direction shown in the label.



 When re-installing the cover of battery box, use your fingers to squeeze the side of rubber plug to exhaust air out of the box and ensure sealing.

3. Self-inspection

When the batteries are successfully installed, the red indicator light will flash once.

Daily maintenance

Main unit care and maintenance

Use only a soft, damp cloth to clean.
Avoid using harsh chemicals.

Note: If the toilet is with off-seat auto flushing function, it may activate auto flushing during the cleaning.

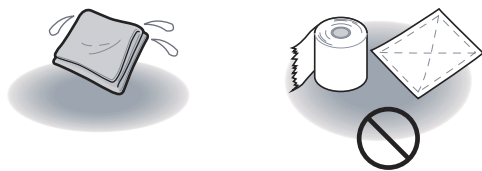
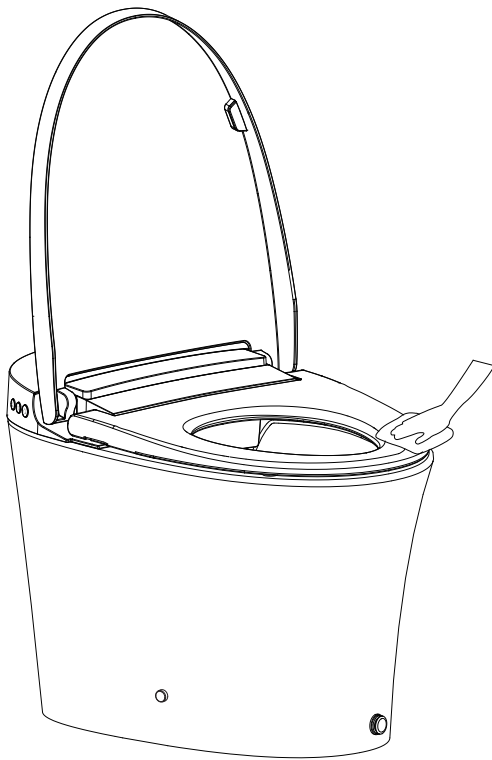

Maintenance of filter net

Time for maintenance: It is under normal water pressure but poor flush performance occurs.

1. Turn off power and the angle valve
2. Unscrew angle valve nut

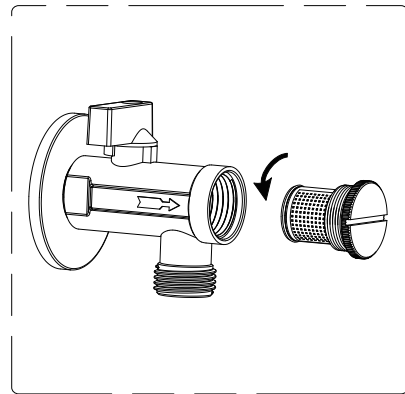

3. Remove filter net

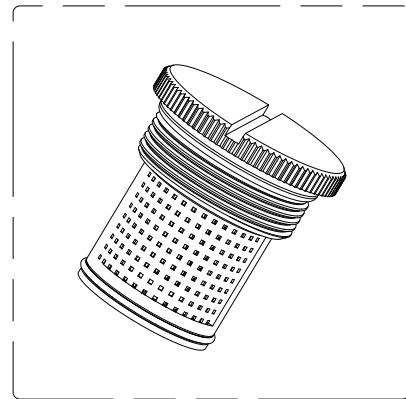

4. Use the brush to clean filter net
5. Reinstall filter net and angle valve nut
6. Turn on the angle valve and connect power, then it can work normally after self inspection.

Emergency Troubleshooting

No water supply

- Put around 2.1Gal (8L) water into a barrel and flush the bowl .

Note: Avoid water spilling from bowl.

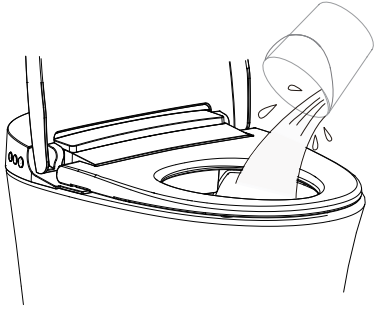

Replacement of battery

- Unplug the DC plug of the battery box and remove the battery box from the bottom of the toilet.
- Remove the cover of battery box and replace old batteries with new batteries, and then re-install the cover.
- Insert the DC plug of battery box into the DC socket of toilet and then stick the battery box to the Velcro on the bottom of the toilet.

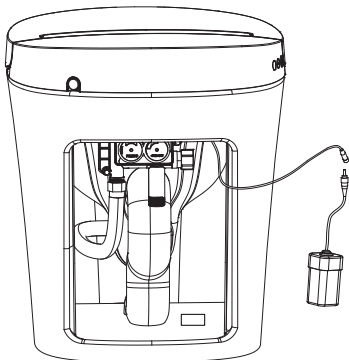

Notes:

1. Must be 1.5V "AA" alkaline battery;
2. Different brands, different used and new batteries cannot be mixed.
3. Battery life will be significantly reduced when using non-alkaline batteries;
4. When installing the inner box components, follow the installation direction shown in the label.

When the product is left unused for long time

- Especially in winter when no one at home for a long time, please drain out the water inside tank and pipe to prevent freezing.

To discharge water

1. Drain out the water in the bowl
 - Activate flushing, and then turn off angle valve to prevent water inlet.
2. Unplug and remove the battery box and then remove all batteries.
3. Drain out the water inside pipe
 - Unscrew the hose connector off angle valve, drain the water in the pipe and reinstall.

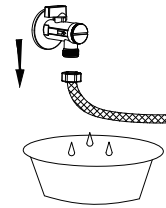

4. Handle the remaining water in bowl
 - It is suggested to put some antifreeze into water inside the bowl.

Tips: When using the toilet again, re-connect the water supply and re-install the battery box.



Note: Before draining out the water inside the pipe, please ensure drain out the water in the bowl first!

Technical Specification

Model		W5100S
Main Unit	Rated Voltage	DC:6V
	Rated Power	2.1W
	IP Rating	IPX4
Toilet	Flush volume	1.28Gpf (4.8Lpf)
	Flush Type	Siphonic jet
	Roughing in	S-trap 305mm
	Sewage outlet diameter	≤100mm
	Water pressure range	0.09MPa (dynamic water pressure, flow rate 3.96Gal/min (15.0L/min) or more)--0.8MPa (static water pressure)
	Installation method	Glass cement/ foundation bolts
seat	Open and close device	Quiet soft-closing device
Caring device	Automatic flushing	Toilet will automatically flush as user walks away from bowl
	Low battery indication	If the battery is low, when pressing the flush button, the indicator light will flash, indicating batteries need to be replaced.
	Foot-touch flushing function	Kick the foot-touch button to flush
Antibacterial position		Seat

The illustration of Main Unit Buttons

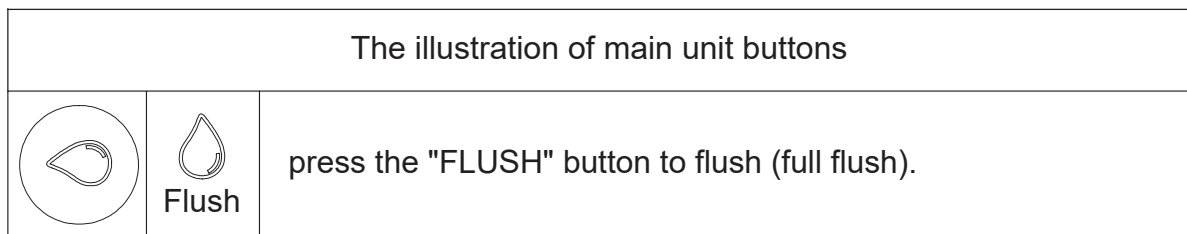

Notes:

1. Button light: If the battery is low, when pressing the flush button, the red light will flash.
2. Off-seat auto flushing: In the off-seat auto flushing mode, if a user seated for ≥6s, and leaves the seat for >3s, the toilet will activate a full flush.

Warranty Terms

1. One-year limited warranty for commercial installation, and two-year limited warranty for residential installation.
2. R&T warrants its product to be free from defects in materials and workmanship during normal use when properly installed and serviced, for a period of one year for commercial or two years for residential from date of shipment. This limited warranty is only to the ORIGINAL PURCHASER of the Products and is not transferable to any third party, including but not limited to any subsequent purchaser or owner of the Product. This warranty applies only to the R&T's product purchased and installed in USA.
3. R&T's obligations under this warranty are limited to repair, replacement or other appropriate adjustment, at R&T's option, of the Product or parts found to be defective in normal use, provided that such Product was properly installed, used and serviced in accordance with instructions. R&T reserves the right to obtain necessary information including the claimed product to conduct investigation in order to determine the cause of the defect. R&T is not responsible for the cost of removal, return and/or reinstallation of the Product.
4. This warranty does not apply to the following items:
 - a) Damage or loss sustained in a natural calamity such as fire, earthquake, flood, thunder, electrical storm, etc.
 - b) Damage or loss resulting from any accident, unreasonable use, misuse, abuse, negligence, improper care or maintenance of the Product.
 - c) Damage or loss resulting from sediments or foreign matter contained in a water system.
 - d) Damage or loss resulting from the quality of water in the region where the product is used.
 - e) Damage or loss resulting from improper installation or from installation of the Product in a harsh and/or hazardous environment, or improper removal, repair or modification of the Product. This includes locations where the water pressure is above local codes or standards.
 - f) Damage or loss resulting from electrical surges or lightning strikes or other acts which are not the fault of the manufacturer or which the Product is not specified to tolerate, including failure to use the factory equipped cord and plug or use of a loose or faulty electrical outlet or use of a current or socket other than a 110V, 60Hz electrical current from a GFI (ground, fused) socket.
 - g) Damage or loss resulting from normal and customary wear and tear, such as gloss reduction, scratching or fading over time due to use, cleaning practices or water or atmospheric conditions, including but not limited to, the use of bleach, alkali, acid cleaners, dry (powder) cleaners or any other abrasive cleaners or the use of metal or nylon scrubbers.
5. If the warning label placed on the seat is broken or otherwise not intact, this limited warranty is void.
6. In order for this limited warranty to be valid, R&T needs to investigate each case. During this process, the customer needs to provide necessary information for R&T to investigate, including but not limited to photos or videos to demonstrate the reported issue, purchase order number, production date or tracking information coming with the product.
7. This warranty gives you specific legal rights. You may have other rights which vary from state to state, province to province or country to country.

WARNING! R&T shall not be responsible or liable for any failure of, or damage to, this Product caused by either chloramine in the treatment of public water supply or cleaners containing chlorine (calcium hypochlorite).

NOTE: The use of a high concentrate chlorine or chlorine related products can seriously damage the fittings. This damage can cause leakage and serious property damage.

THIS WRITTEN WARRANTY IS THE ONLY WARRANTY MADE BY THE MANUFACTURER. REPAIR, REPLACEMENT OR OTHER APPROPRIATE ADJUSTMENT AS PROVIDED UNDER THIS WARRANTY SHALL BE THE EXCLUSIVE REMEDY AVAILABLE TO THE ORIGINAL PURCHASER. THE MANUFACTURER SHALL NOT BE RESPONSIBLE FOR LOSS OF THE PRODUCT OR FOR OTHER INCIDENTAL, SPECIAL OR CONSEQUENTIAL DAMAGES OR EXPENSES INCURRED BY THE ORIGINAL PURCHASER, OR FOR LABOR OR OTHER COSTS DUE TO INSTALLATION OR REMOVAL, OR COSTS OF REPAIRS BY OTHERS, OR FOR ANY OTHER EXPENSE NOT SPECIFICALLY STATED ABOVE. IN NO EVENT WILL THE MANUFACTURER'S RESPONSIBILITY EXCEEDS THE PURCHASE PRICE OF THE PRODUCT. EXCEPT TO THE EXTENT PROHIBITED BY APPLICABLE LAW, ANY IMPLIED WARRANTIES, INCLUDING THAT OF MERCHANTABILITY OR FITNESS FOR USE OR FOR A PARTICULAR PURPOSE, ARE EXPRESSLY DISCLAIMED.



R&T®

Xiamen R&T Plumbing Technology Co.,Ltd.

Add: No. 18, Houxiang Road, Haicang District, Xiamen, China

Tel: 86-0592-6539788

Fax: 86-0592-6539723

E-mail: rt@rtplumbing.com

Http: [//www.rtplumbing.com](http://www.rtplumbing.com)

The picture of product may not entirely consistent with actual appearance and color because of products improvement, please in kind prevail.