

Assembly Instruction

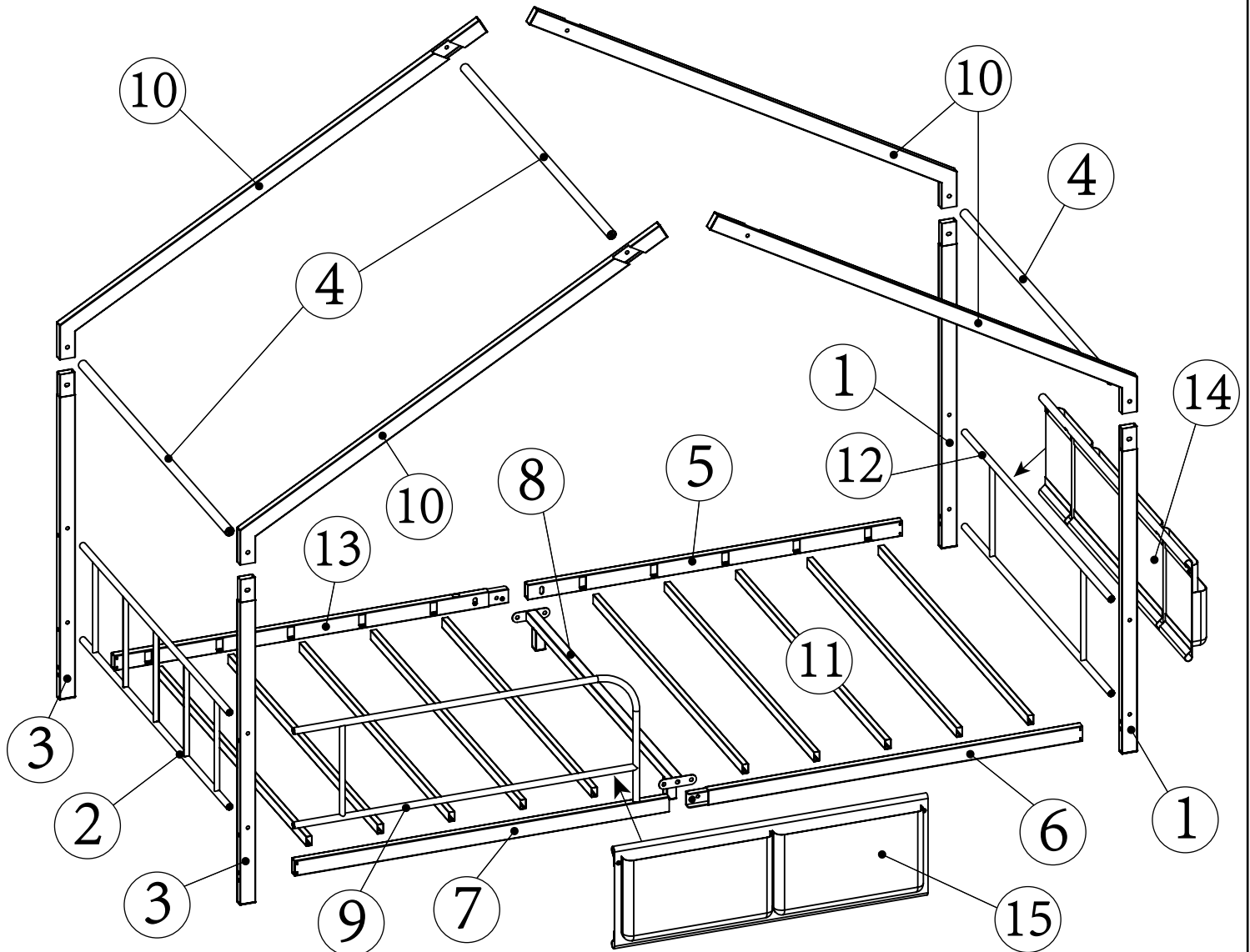

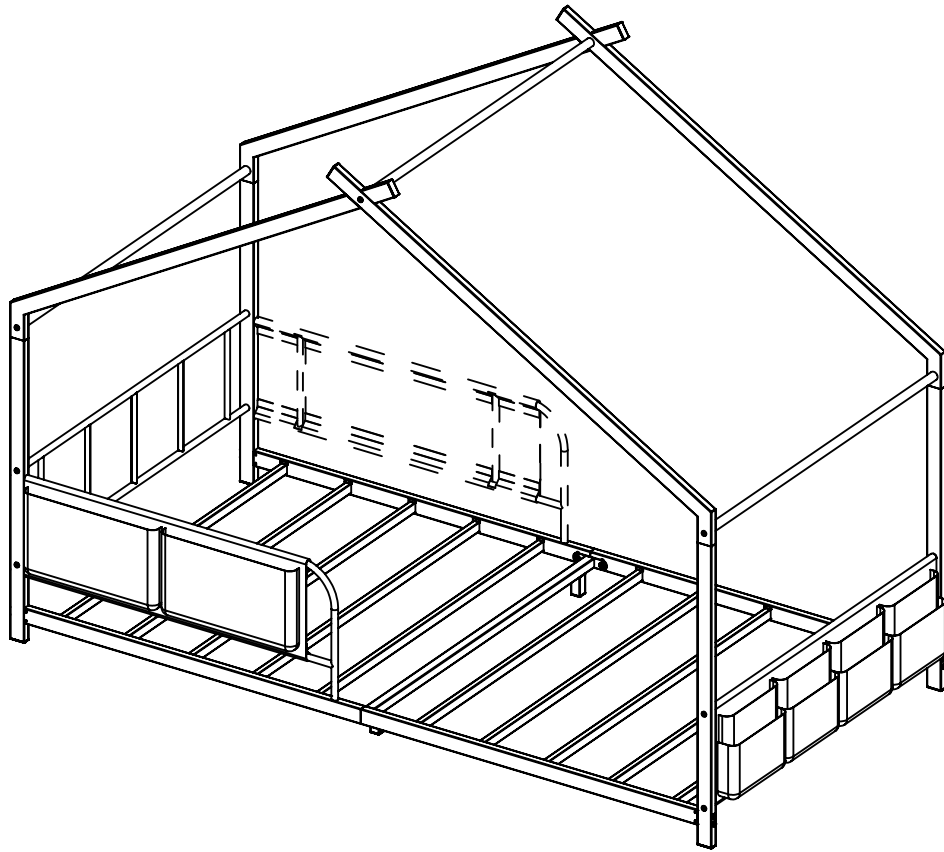

Difference screws display(1:1)

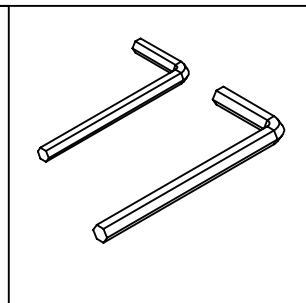
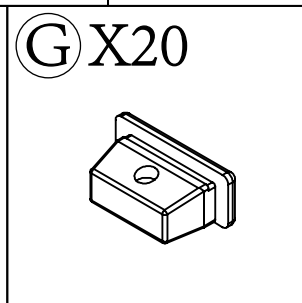
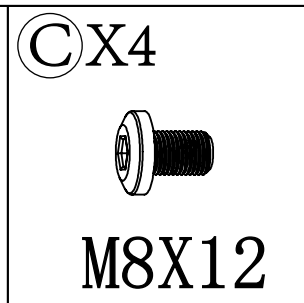
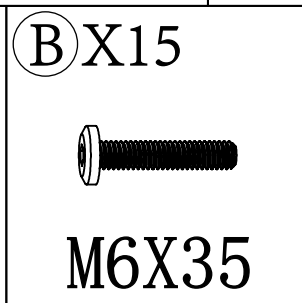
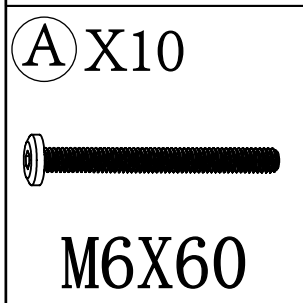
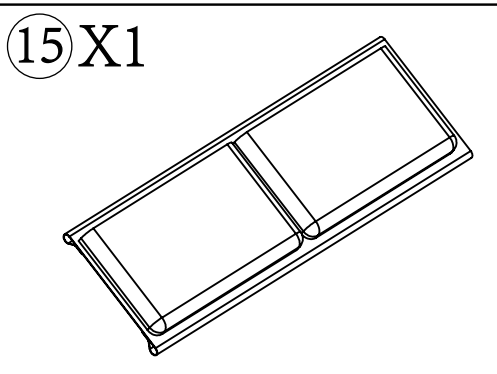
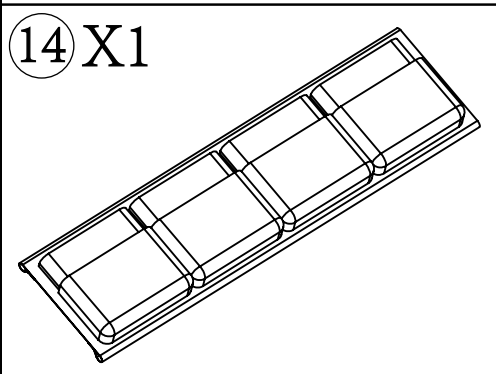
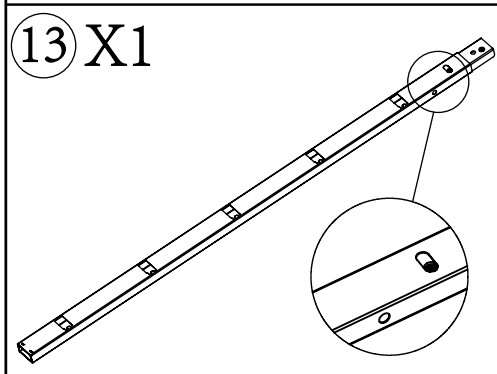
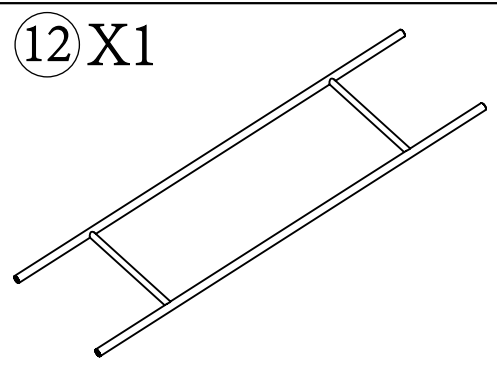
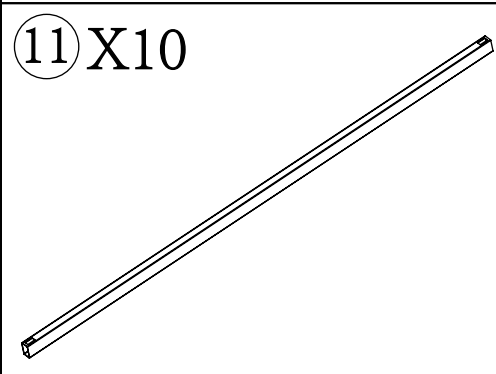
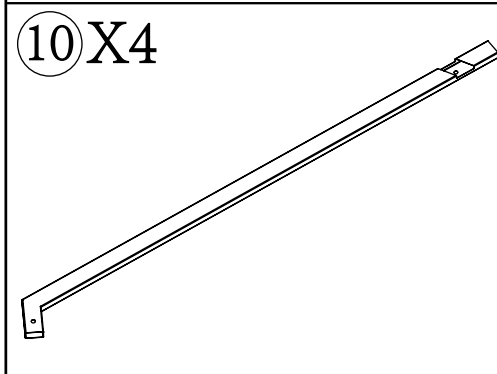
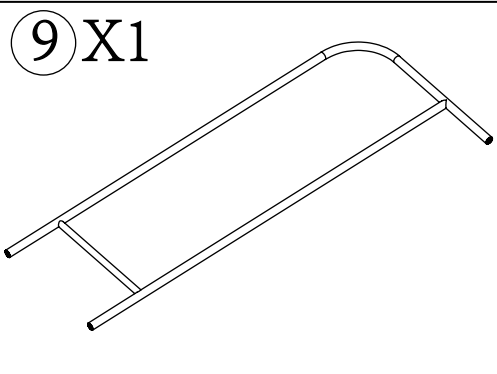
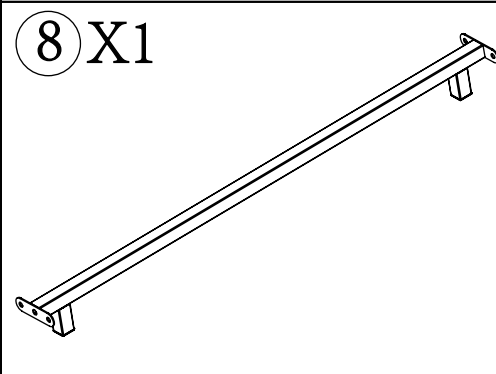
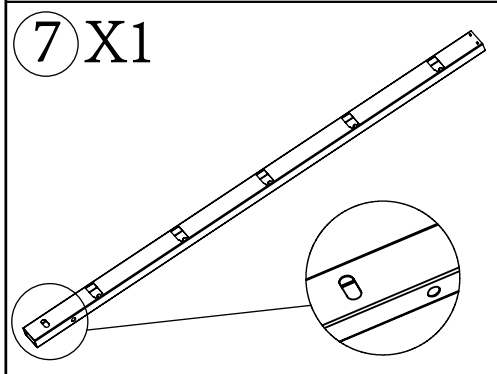
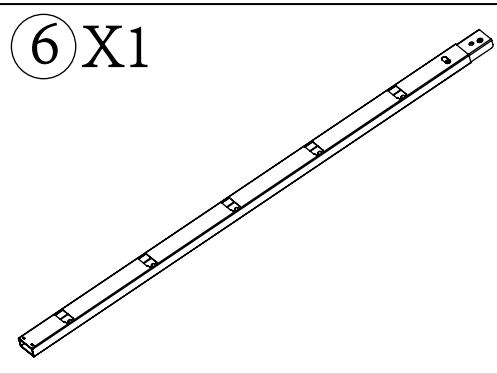
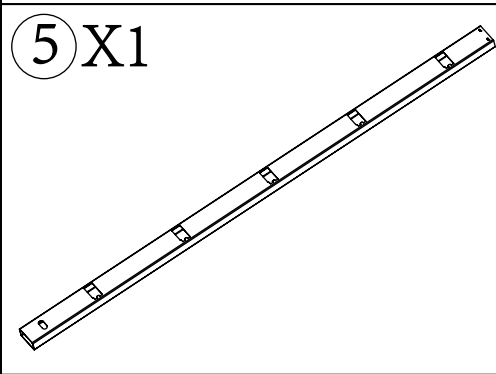
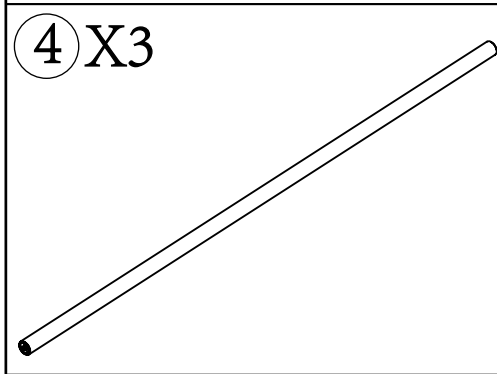
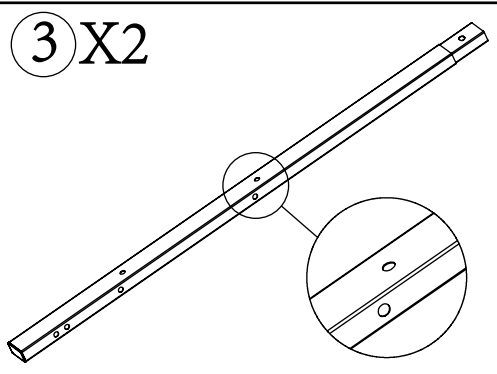
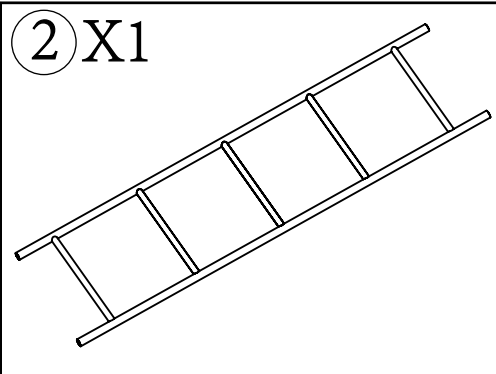
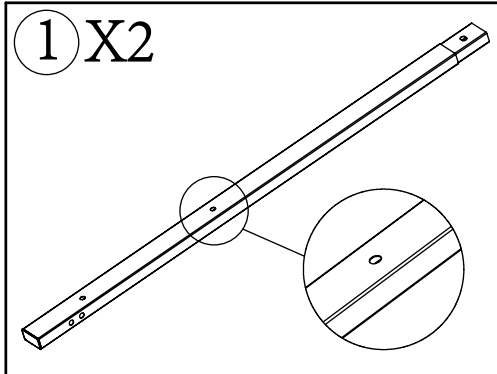
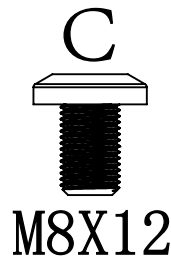
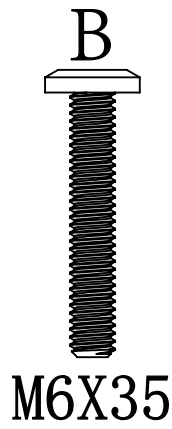
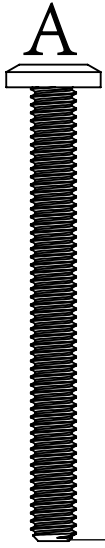

M6:Screw outer diameter 6mm
M8:Screw outer diameter 8mm

HARDWARE NOTE:

1. Assembly is recommended for two or more people.
2. Do not tighten the bolts until the assembly process is fully completed. Please make sure all bolts are tightened before use.

Step 1

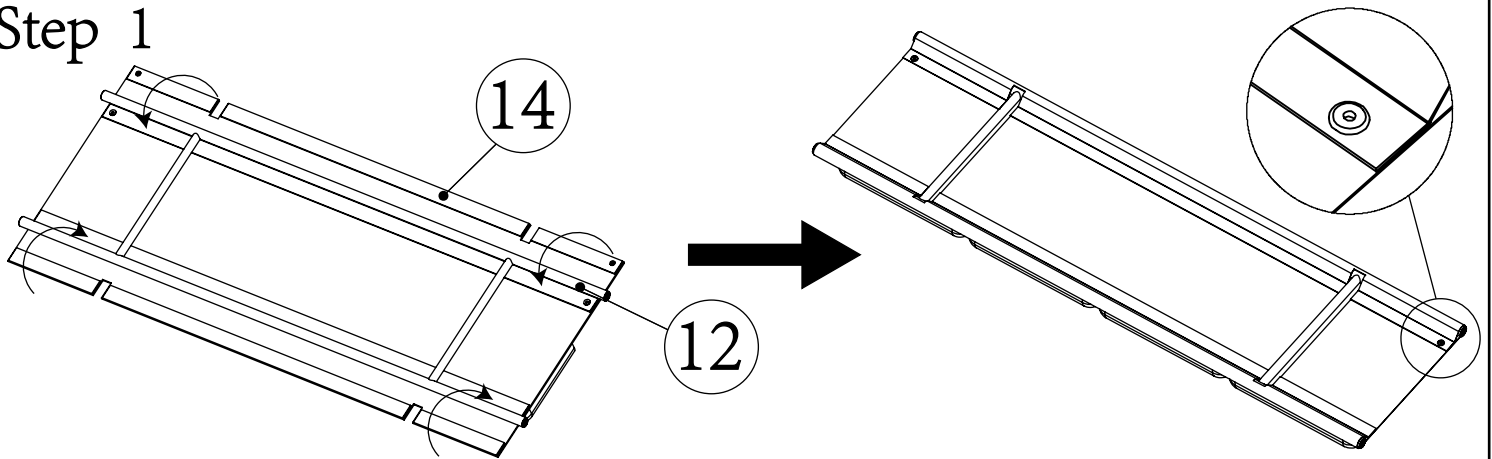

Step 2

B	M6X35	4
---	-------	---

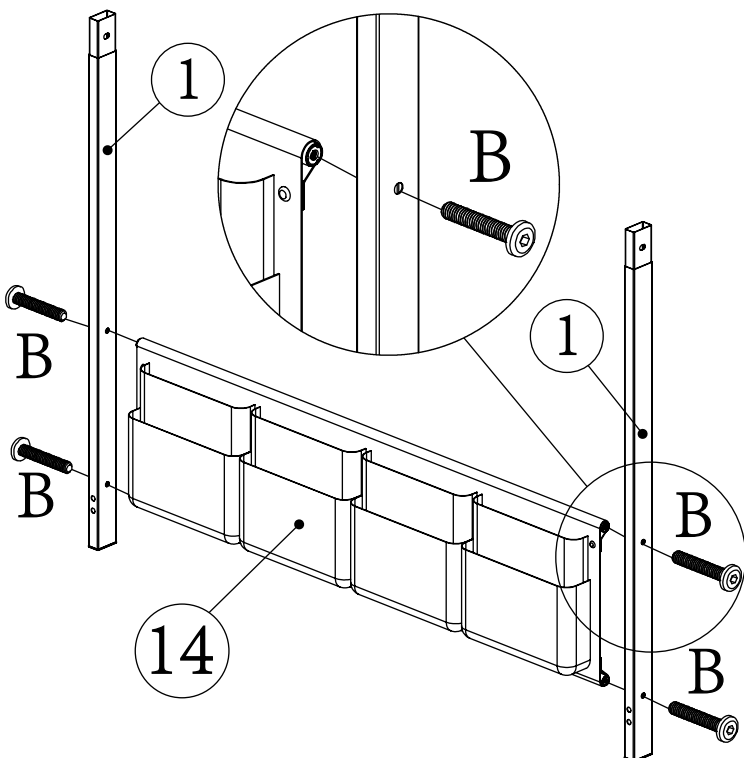

Step 3

B	M6X35	4
---	-------	---

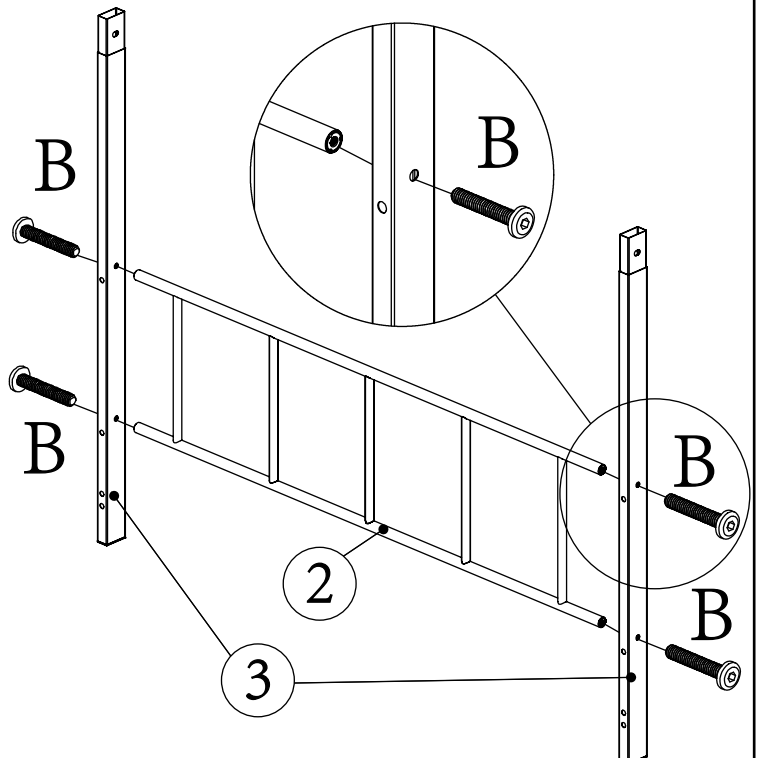

Step 4

C M8X12 4

Please pay attention to distinguish the different orientations of the tube as shown in the figure.

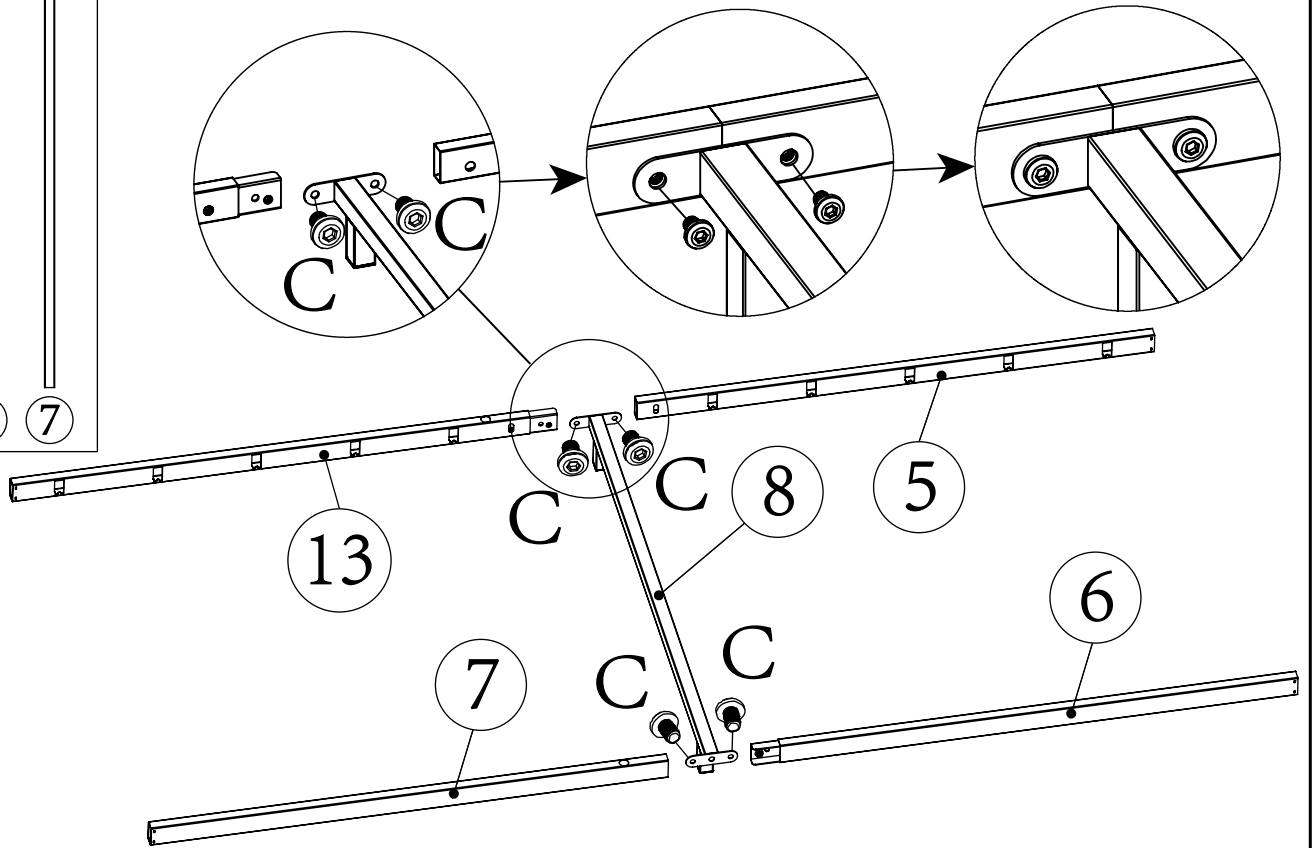
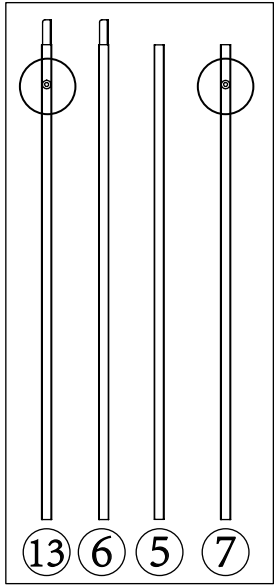

Step 5

A M6X60 8

Step 3

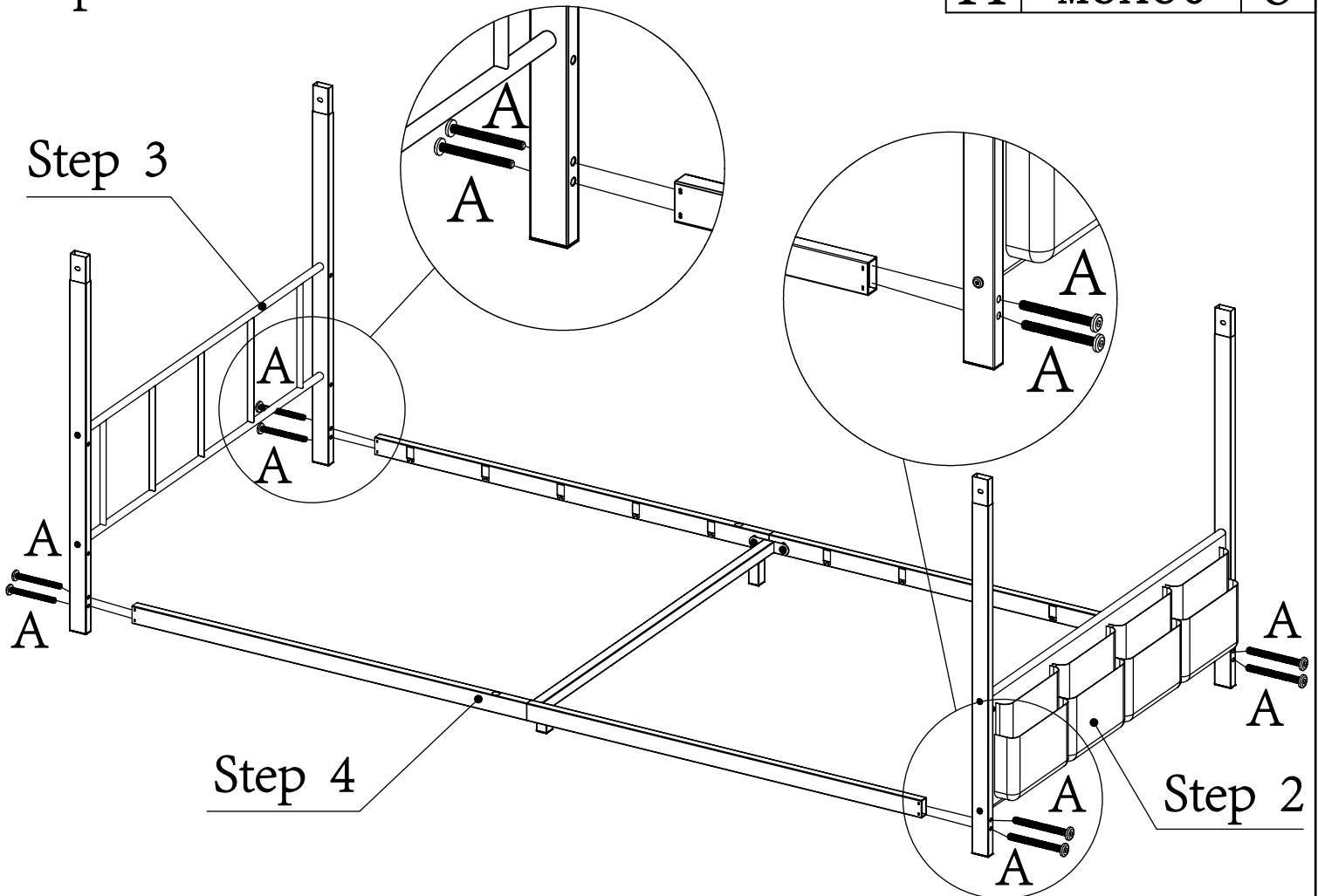

Step 6

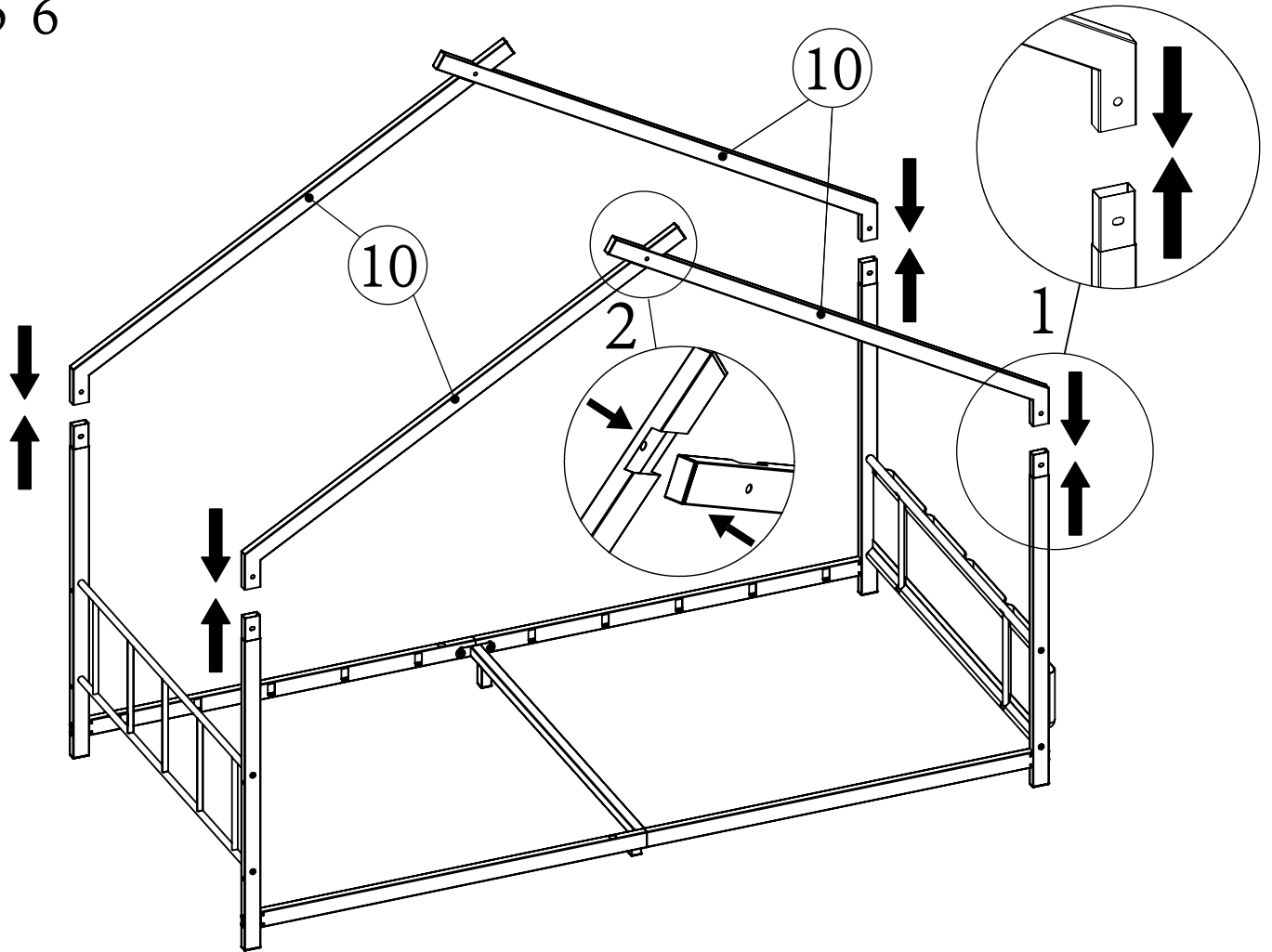

Step 7

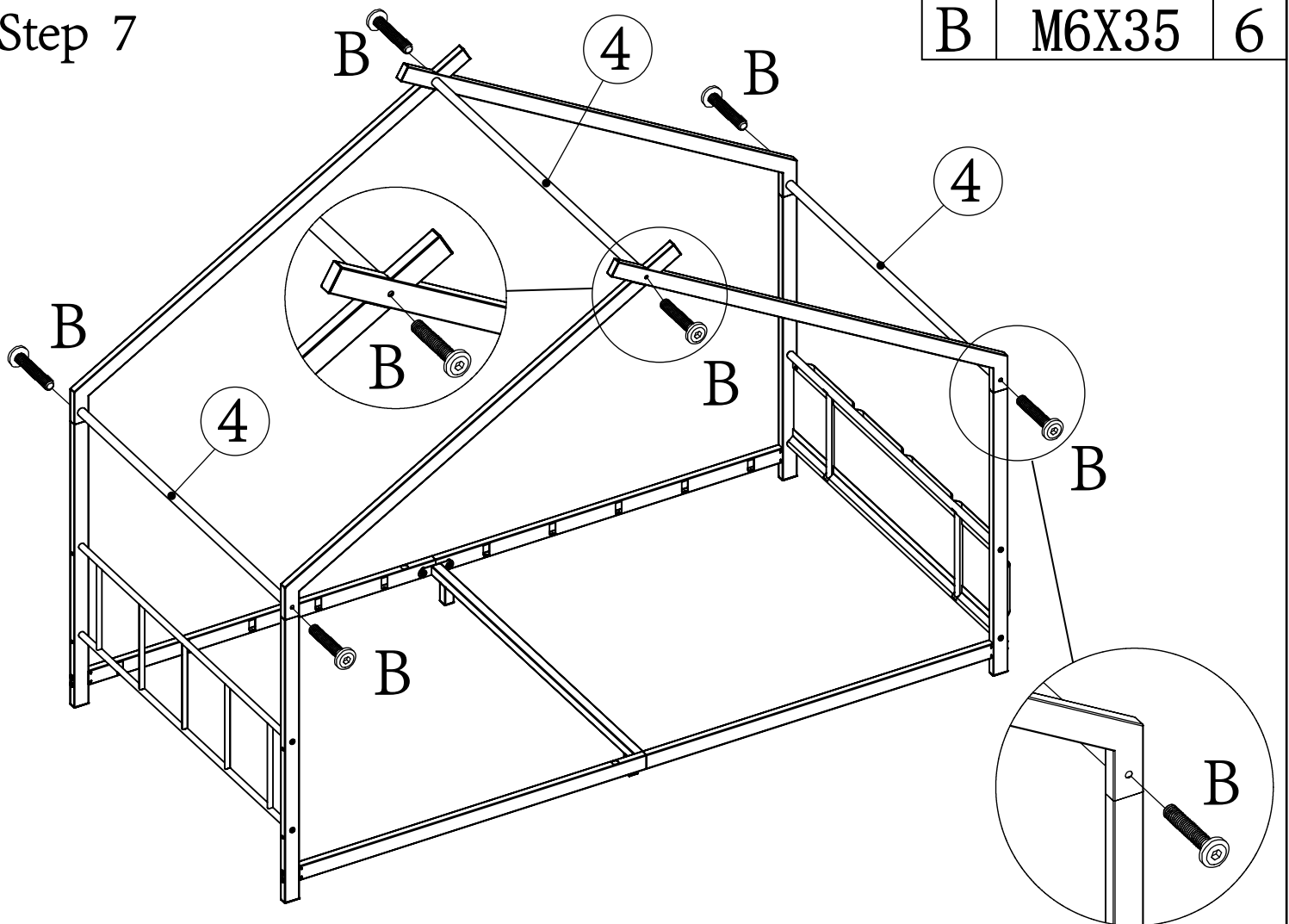

Step 8

A	M6X60	2
B	M6X35	1

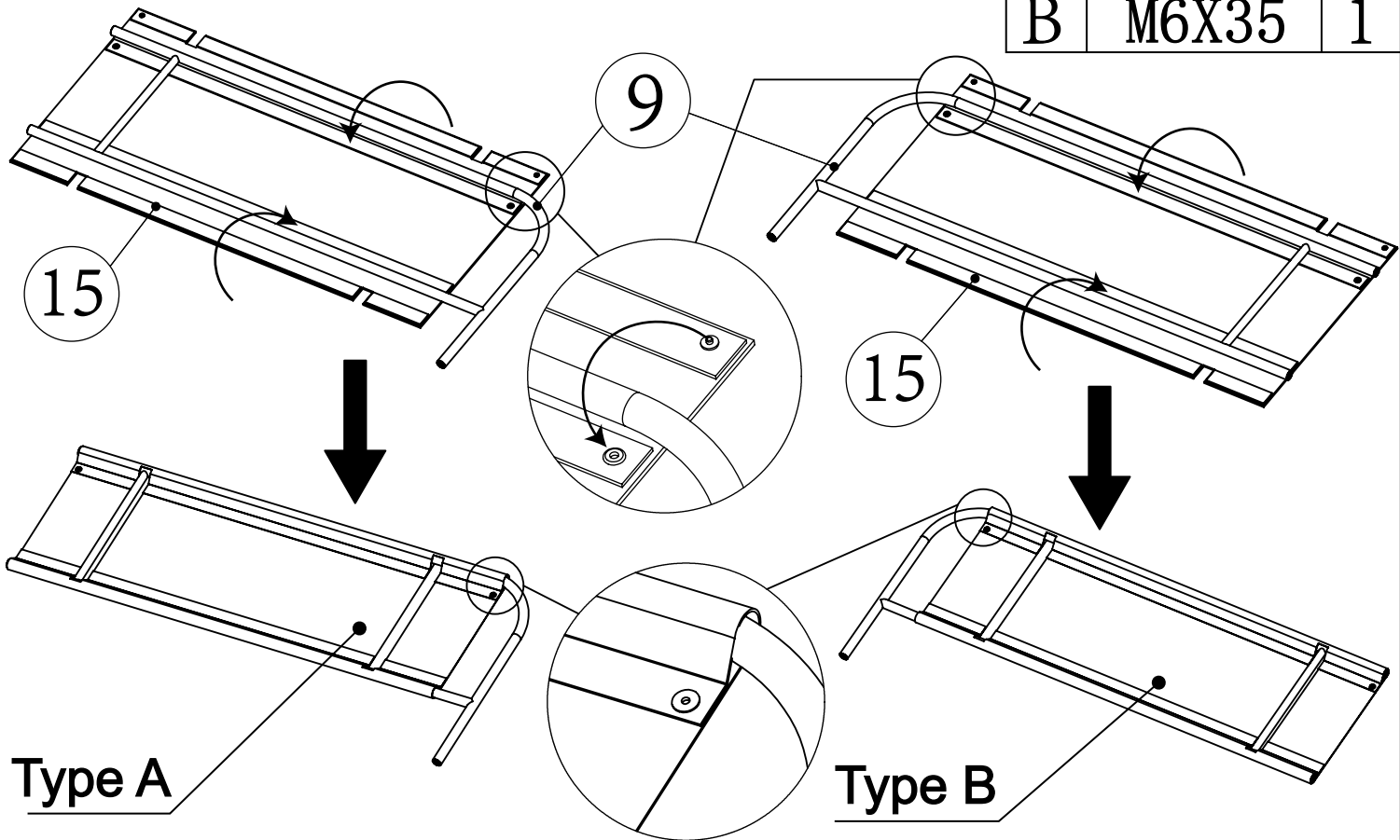

Assemble the Guardrail No.9 according to your specific needs.

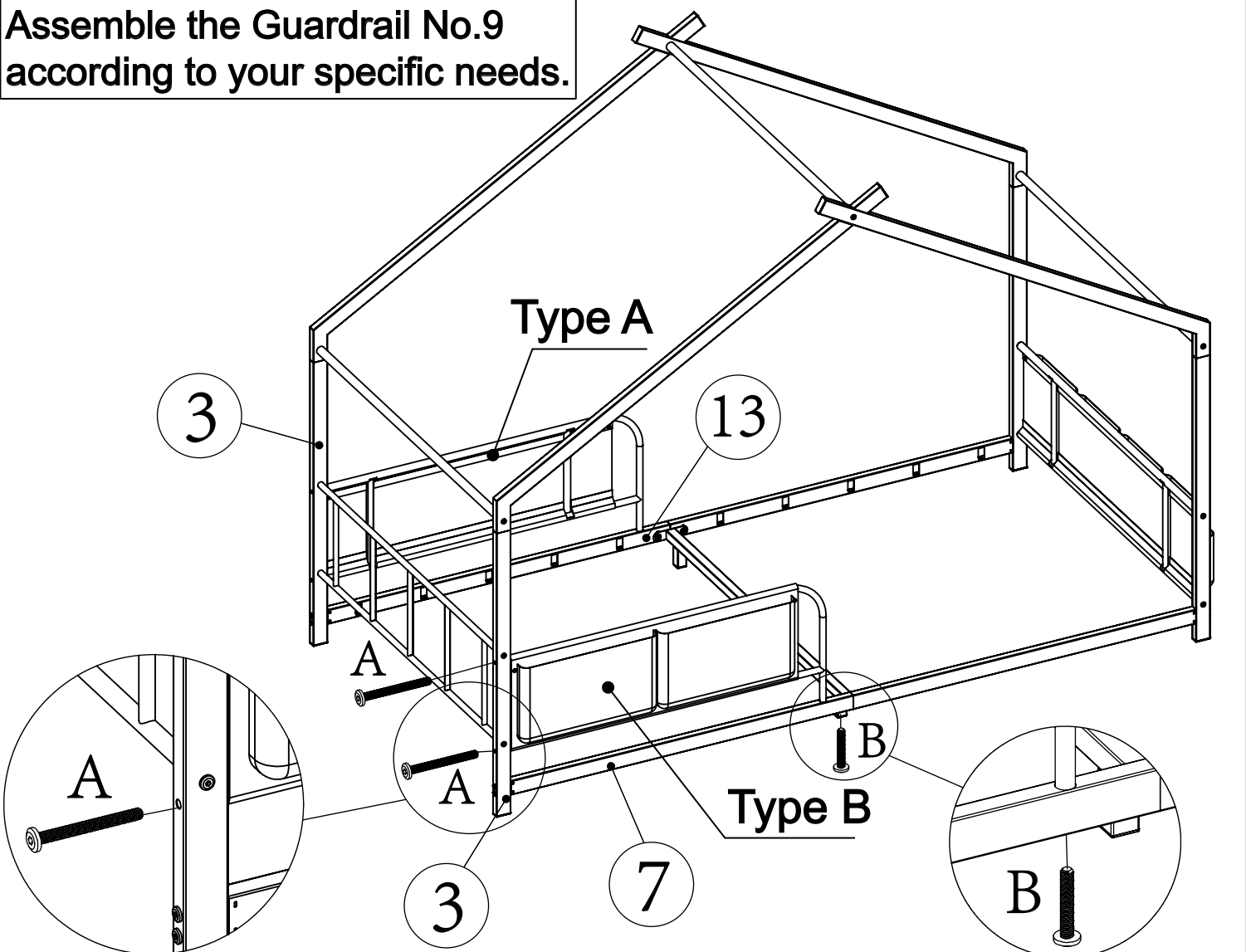

Step 9

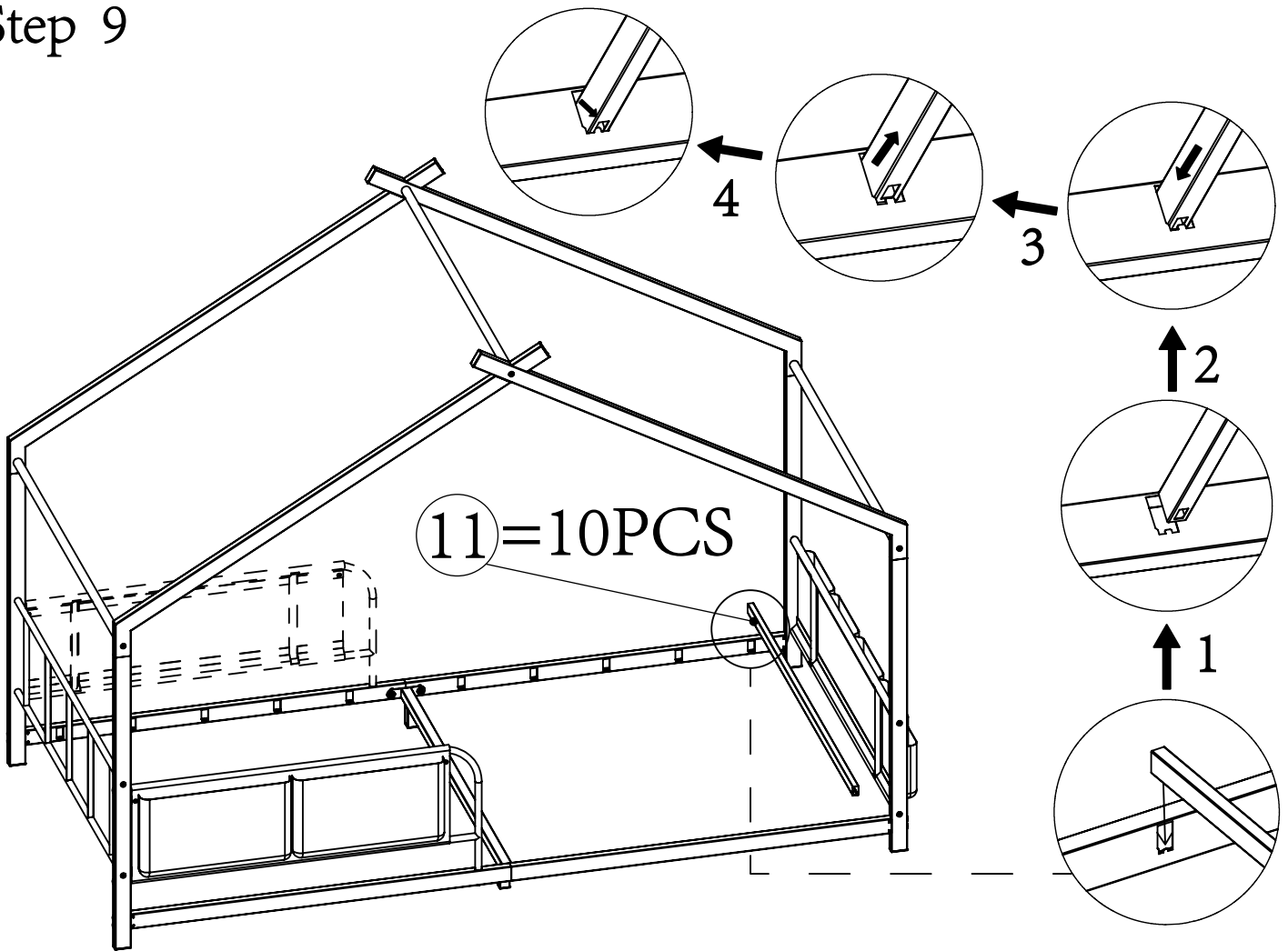

Step 10

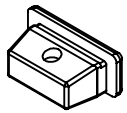

G=20PCS

