

ASSEMBLY INSTRUCTIONS

COFFEE TABLE

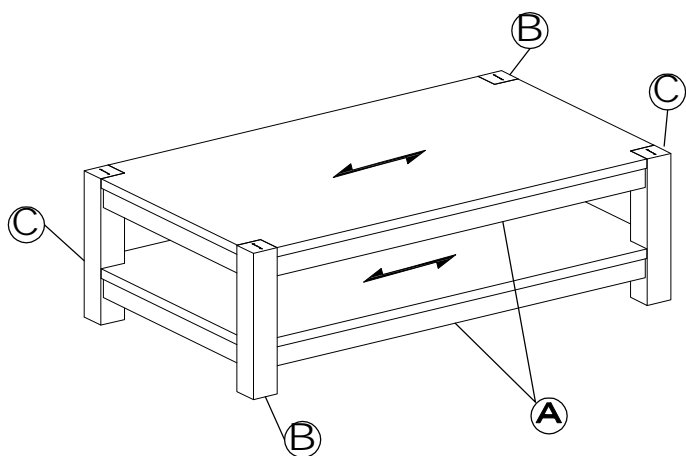

PARTS CHECK LIST

CODE	COMPONENTS	QTY
Ⓐ	TABLE TOP	x02
Ⓑ	RIGHT LEG	x02
Ⓒ	LEFT LEG	x02

Hardware Check List

code	description	qty
01	BOLT	x08
02	SPRING WASHER	x08
03	FLAT WASHER	x08
04	ALLEN KEY	x01

- PLEASE DO NOT DISCARD ANY OF THE PACKAGING UNTIL YOU HAVE CHECKED ALL THE PARTS AND THE PACKS OF HARDWARE.
 - BEFORE YOU BEGIN TO ASSEMBLE YOUR NEW PIECE OF FURNITURE, PLEASE CHECK TO ENSURE THAT ALL PARTS HAVE BEEN SUPPLIED.
 - FOLLOW INSTRUCTIONS CLOSELY AS DEVIATION FROM THEM MAY VOID YOUR WARRANTY AND PRESENT A POSSIBLE SAFETY RISK.
 - IT IS RECOMMENDED THAT ASSEMBLY IS DONE ON A SOFT SURFACE LIKE CARPET TO AVOID ANY DAMAGE.
 - PERIODICALLY CHECK AND RE-TIGHTEN ANY FASTENERS. WIPE DOWN ALL SURFACES WEEKLY WITH A CLEAN CLOTH. DO NOT CLEAN ANY SURFACES WITH HARSH ABRASIVES OR CHEMICALS.

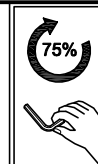
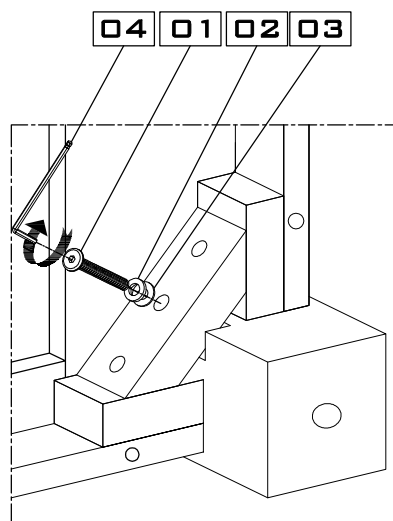
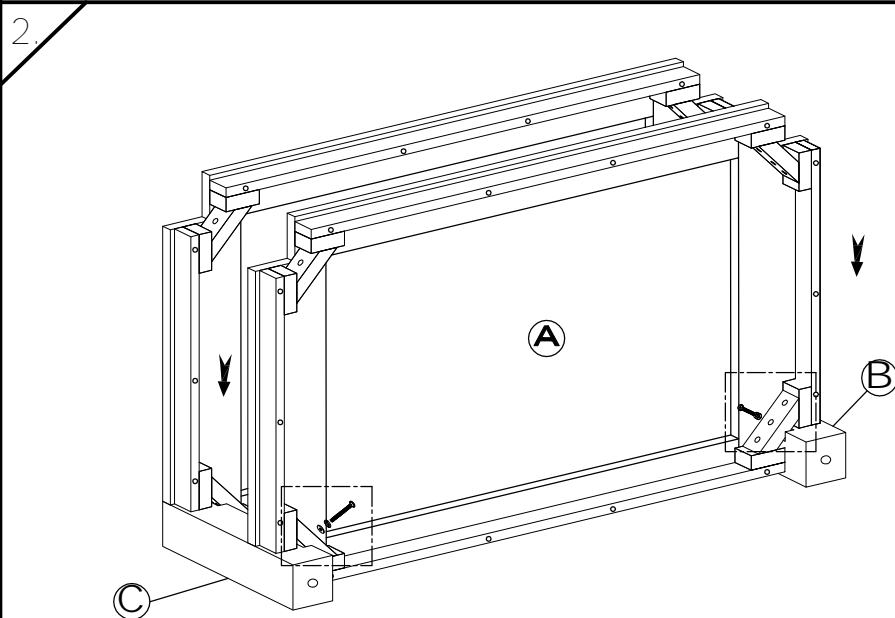
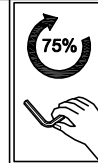
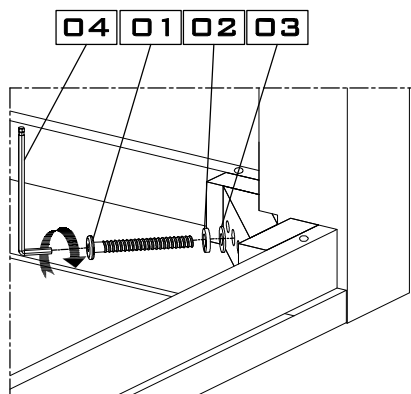
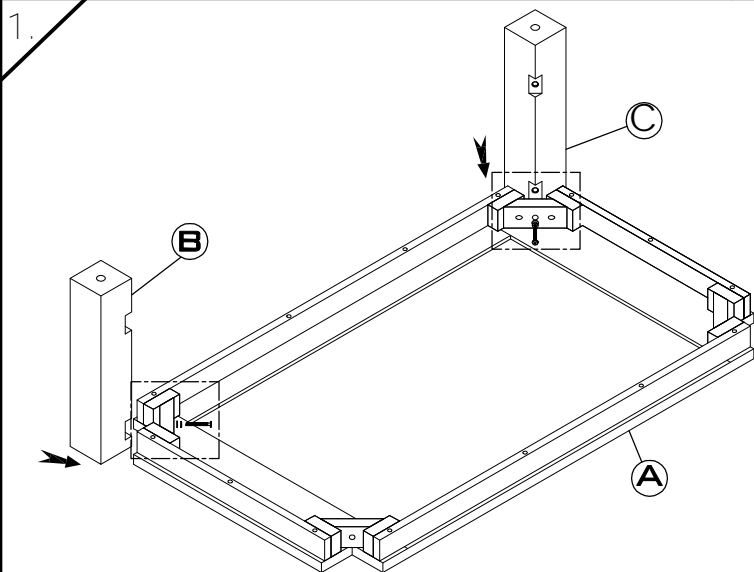

ASSEMBLY INSTRUCTIONS ADLER COFFEE TABLE

3.

- 04
- 01
- 02
- 03

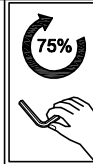
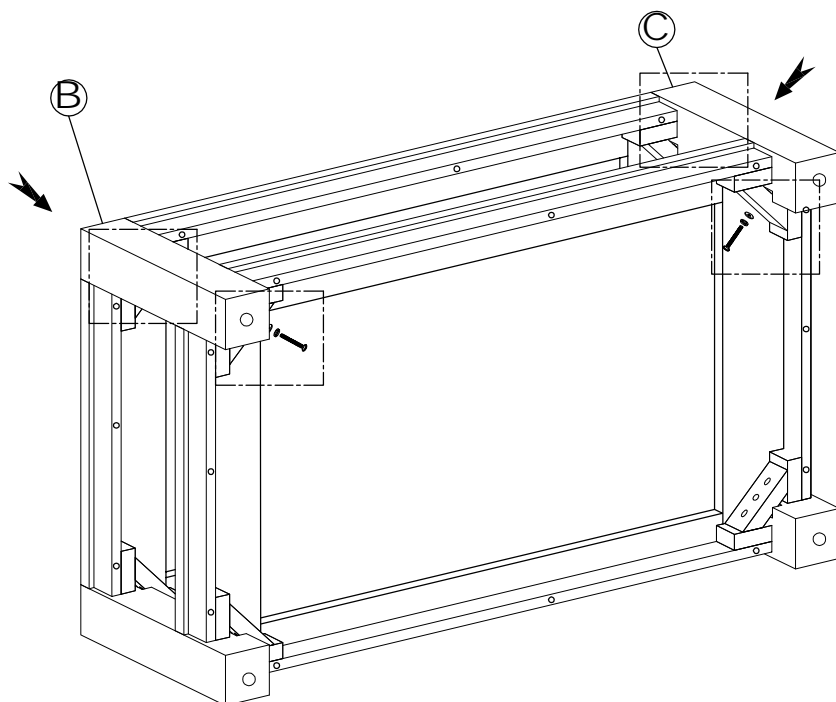
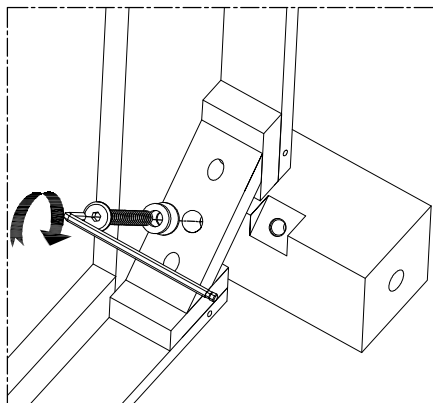
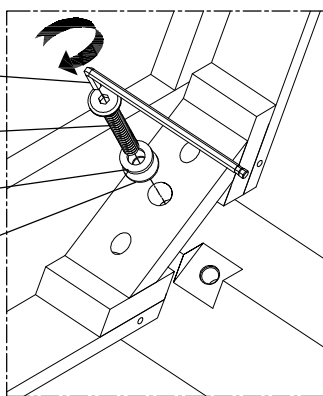

4.

04

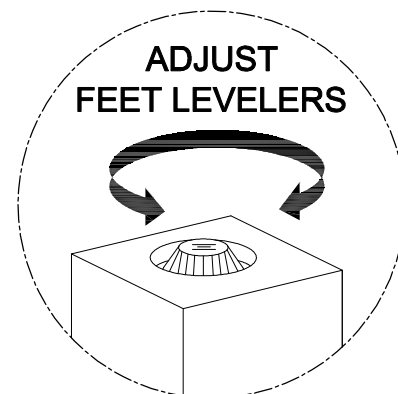
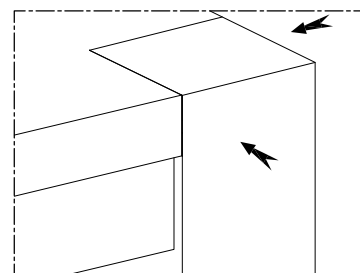
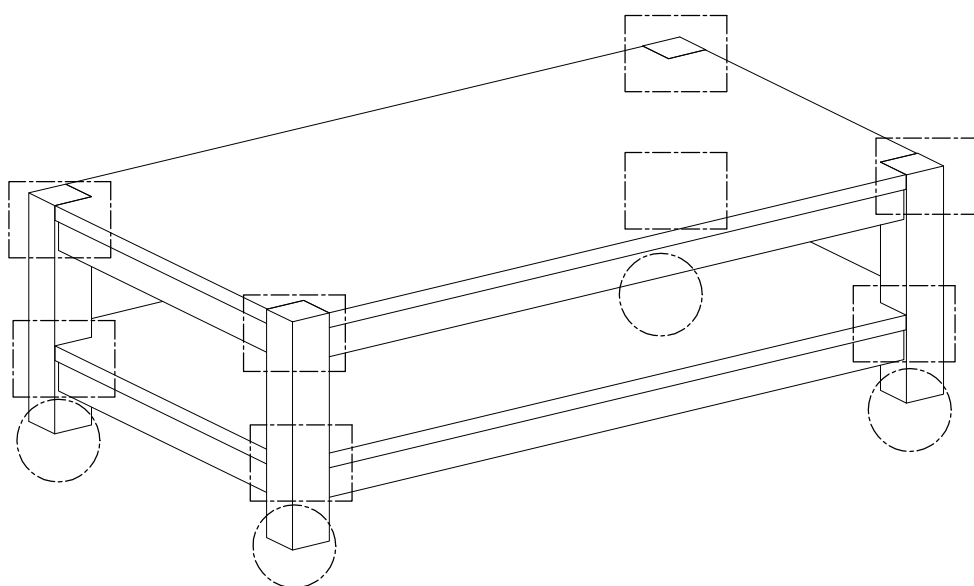
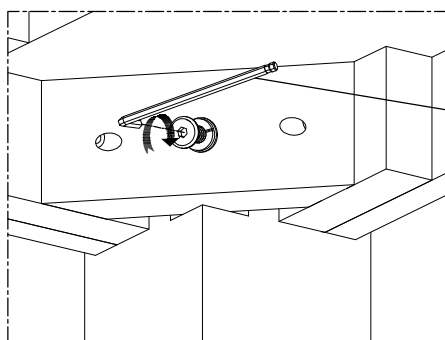

***ROTATE THE TABLE UPRIGHT. ALIGN EACH LEG ON BOTH SIDES. THEN FULLY TIGHTEN ALL BOLTS.**