

CHMC002: 30-Bay USB-C Charging Cart Assembly Instructions

PARTS LIST:

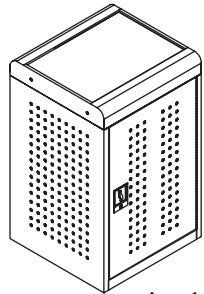

A x 1
Cabinet

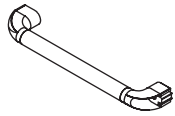

B x 1
Push Handle



C x 2
Handle Corner Cover



D x 1
Cable Wrap

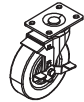

E x 2
Locking Plate Caster



F x 2
Plate Caster

HARDWARE:



G x 16
Caster Screw
M8 x 20mm



H x 16
Caster Split Washer
M8



I x 16
Caster Washer
M8

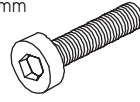

J x 2
Push Handle Screw
M10x40mm

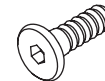

K x 1
Cable Wrap Screw
M10x15mm

ASSEMBLY TOOLS:



L x 1
Large Allen Wrench



M x 1
Small Allen Wrench



N x 2
Keys

ASSEMBLY INSTRUCTIONS:

1

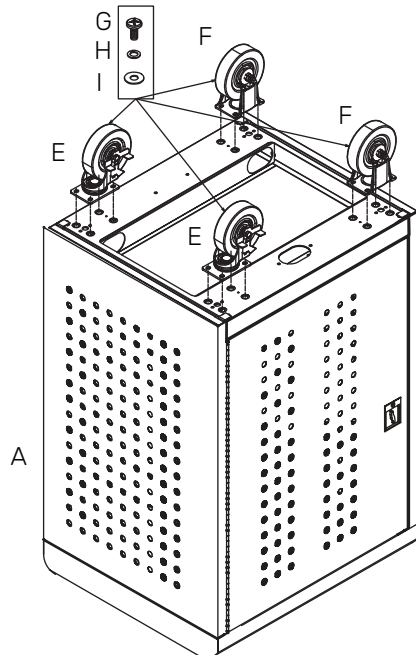

With Cabinet (A) upside down, attach two locking plate casters (E) and two plate casters (F) as shown using Caster Screws (G), Caster Split Washers (H), and Caster Washers (I). Attach Locking Plate Casters (E) to the side with the holes for the Push Handle (B).

2

Align Push Handle (B) as shown, secure using two push handle screws (J) and the Large Allen Key (L). Once Secure, press two Handle Corner Covers (C) into place.

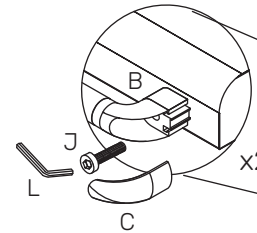

3

Attach Cable Wrap (D) as shown. Secure using Cable Wrap Screw (K) and Small Allen Key (M).

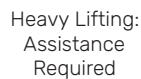
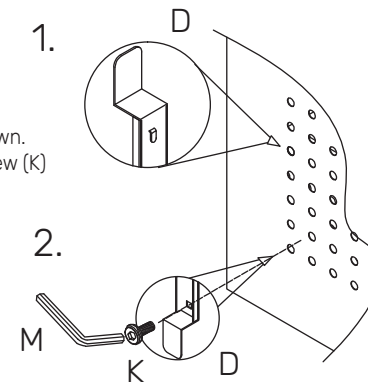

Heavy Lifting:
Assistance
Required