

Assembly Instructions

Caution: You must read this before you proceed.

Care & Maintenance



- Not for commercial use. For residential use only.



- Do not put hot items directly on furniture surface.



- Do not clean furniture with harsh cleansers or polish.

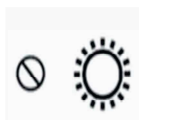

- Do not place furniture under direct sunlight.



- Do not place furniture near heating or cooling vents.

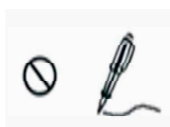

- Do not write on furniture without a padded barrier to protect the surface.



- Do not place furniture outside. For indoor use only.



- Stains may be removed with mild soap solution and damp cloth.



- Children should not climb or jump on the furniture.



- Dust and pick-up spills using a clean, non-colored, lint-free cloth.

Full/Queen Bed

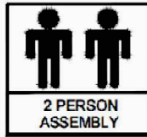
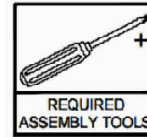
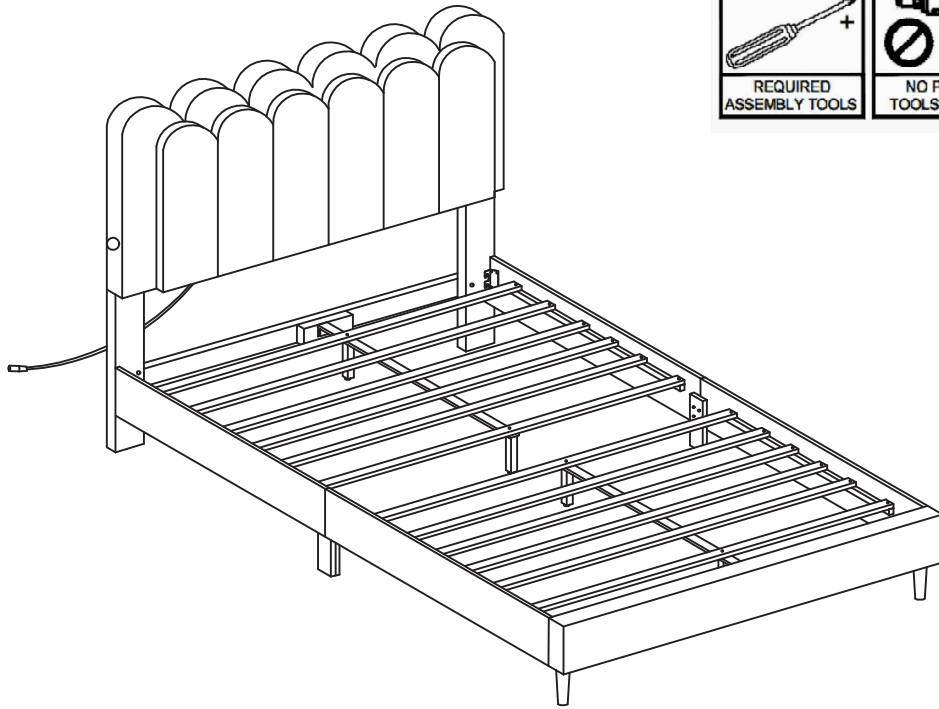

WARNING

STRANGULATION HAZARD.

NEVER place bed near windows where cords from blinds or drapes may strangle a child.

NEVER suspend strings over bed.

NEVER place items with a string, cord, or ribbon, such as hood strings or pacifier cords, around a child's neck. These items may catch on bed parts.

ALWAYS follow assembly instructions.



WARNING!

Not intended for children under the age of six. **INFANTS HAVE DIED FROM BECOMING ENTRAPPED IN BEDS.** Openings in and between bed parts can entrap the neck and head of a small child. NEVER use bed for child under the age of six.

The mattress must be appropriately sized for the bed. If the mattress is undersized, dangerous gaps can exist and a person can become entrapped or entangled in the frame and suffocate.







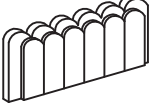
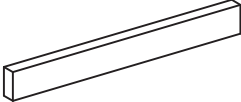
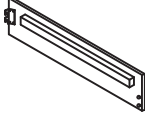
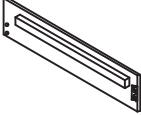

Note: This Bed is NOT a TOY.

Keep your child/ children at bay during the assembly process.



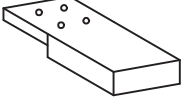
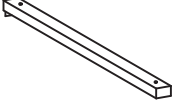
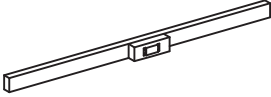

The BED is HEAVY.

To prevent injury to yourself or damage to the product a minimum of two adults are required whenever moving or lifting it.

Part List

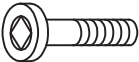
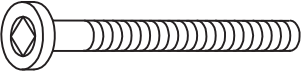
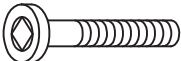
Label	Picture	Description	QTY
A		Headboard	1
B		Footboard	1
C		Side Rail-C	2
D		Side Rail-D	2
E		Headboard Leg L	1
F		Headboard Leg R	1
G		Footboard Legs	2
H		Side Rail Legs	2
I		Center Rail	2
J		Headboard Leg Support Wood	1
K		Front Slat	1
L		Back Slat	1
M		Support Legs	4

Hardware

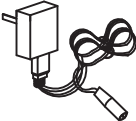
Label	Picture	Description	QTY
①		Allen Key 65mm	1
②		Allen Key 70mm	1
③		JCBB M8 x 20mm	8
④		JCBB M8 x 60mm	4
⑤		JCBC M6 x 30mm	14
⑥		JCBC M6 x 40mm	2
⑦		CSK Screw 32mm	24
⑧		Spring Washer	8
⑨		Flat Washer	10
⑩		Plug	1
⑪		Screwdriver (Not provided)	1

Assembly Preparation

Before Beginning Assembly:

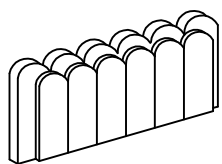

A



F

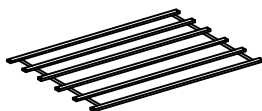

K

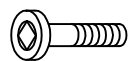

x 8

③



x 8

⑧

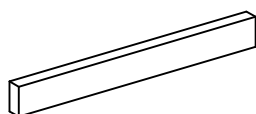

B

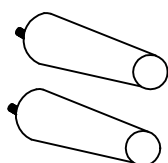

G

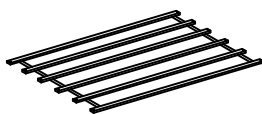

L



x 4

④



x 10

⑨

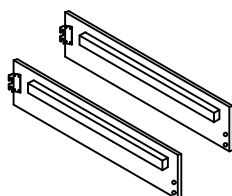

C

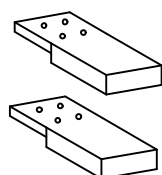

H

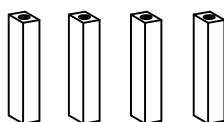

M



x 14

⑤

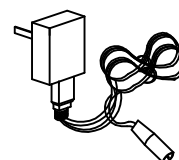

⑩

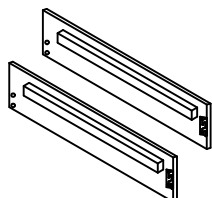

D

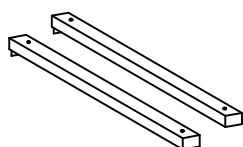

I

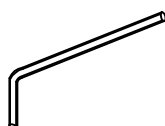

①

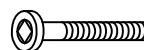

x 1

⑥

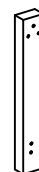

E

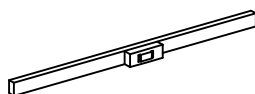

J

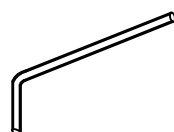

②



x 24

⑦



- Read instructions, cover to cover.



- Have 2 adults on hand for assembly.



- Do not assemble on flooring or carpet.



- Assemble on a clean non-marring surface (packing foam).



- Save all packaging until finished.

Assembly Steps

Overview

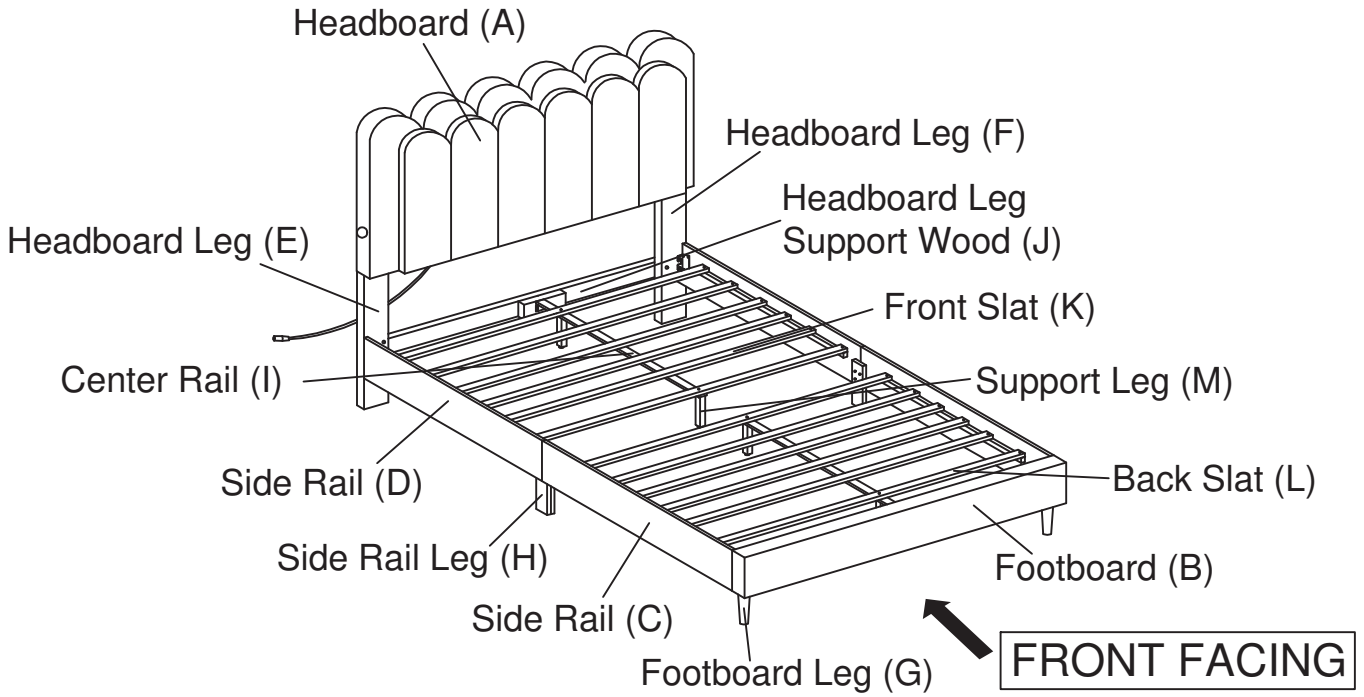

This Bed has multiple parts and may require up to 30 minutes to assemble. To give you an overview of the Bed parts, the above picture is provided to help you put the various parts into perspective. Please read through the instructions below to familiarise yourself with the parts and steps before assembly.

Step 1

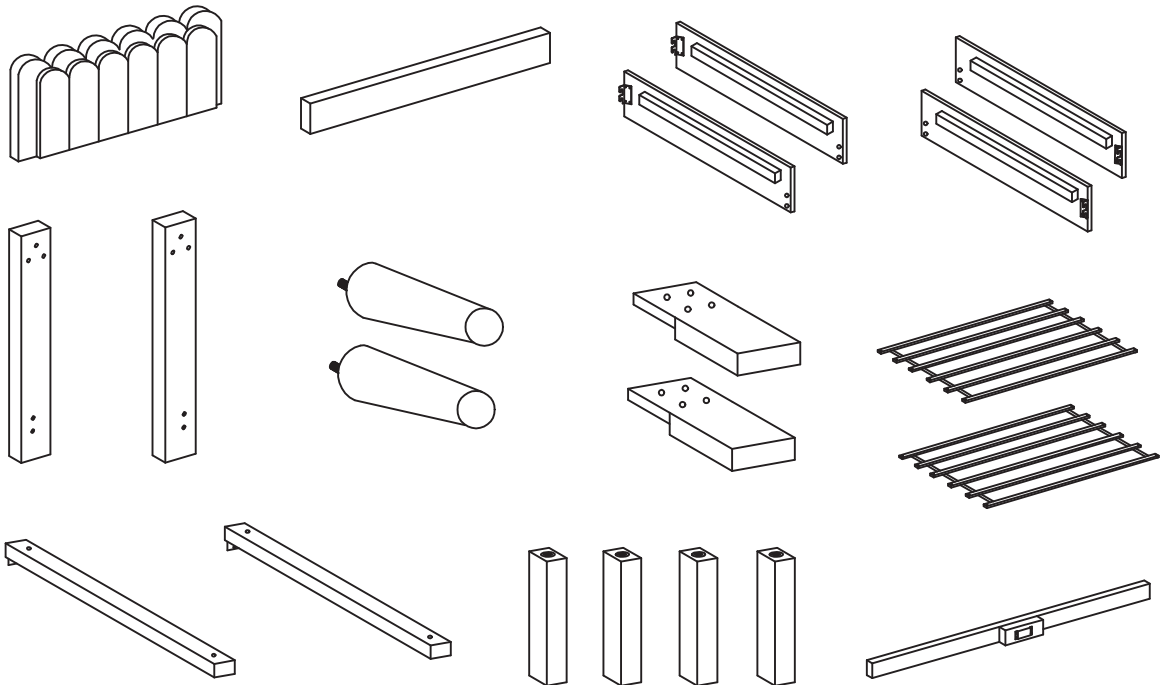

Unpack and place all parts on a clean, non-marring surface.

Step 2

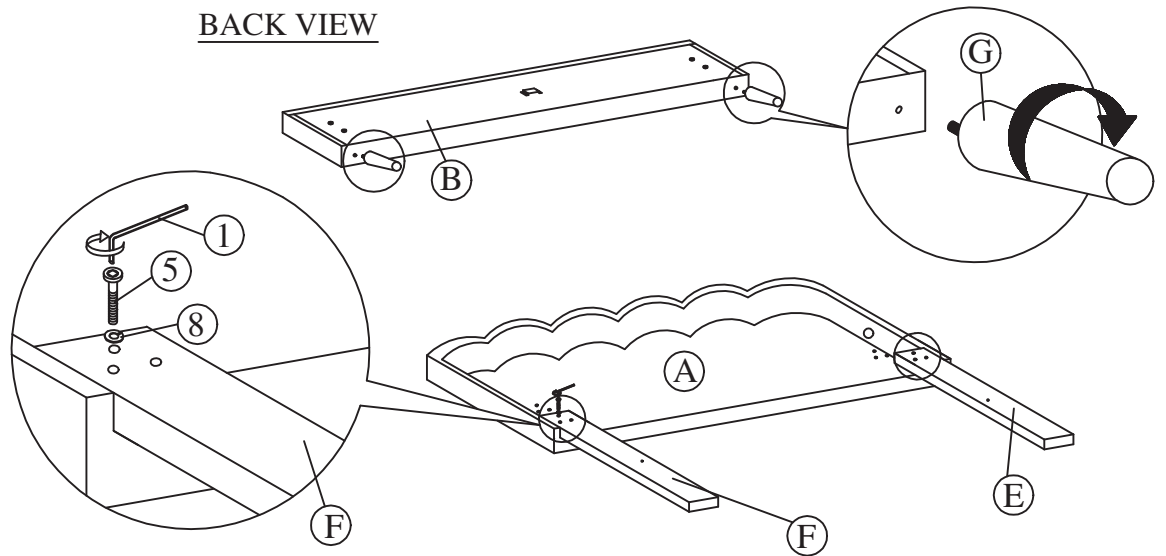

Attach the headboard legs (E/F) to headboard (A) by using Bolt (5), Spring Washer (8) with Allen Wrench (1). Attach the footboard legs (G) with footboard (B) as shown.
FULLY TIGHTEN THE BOLT.

Step 3

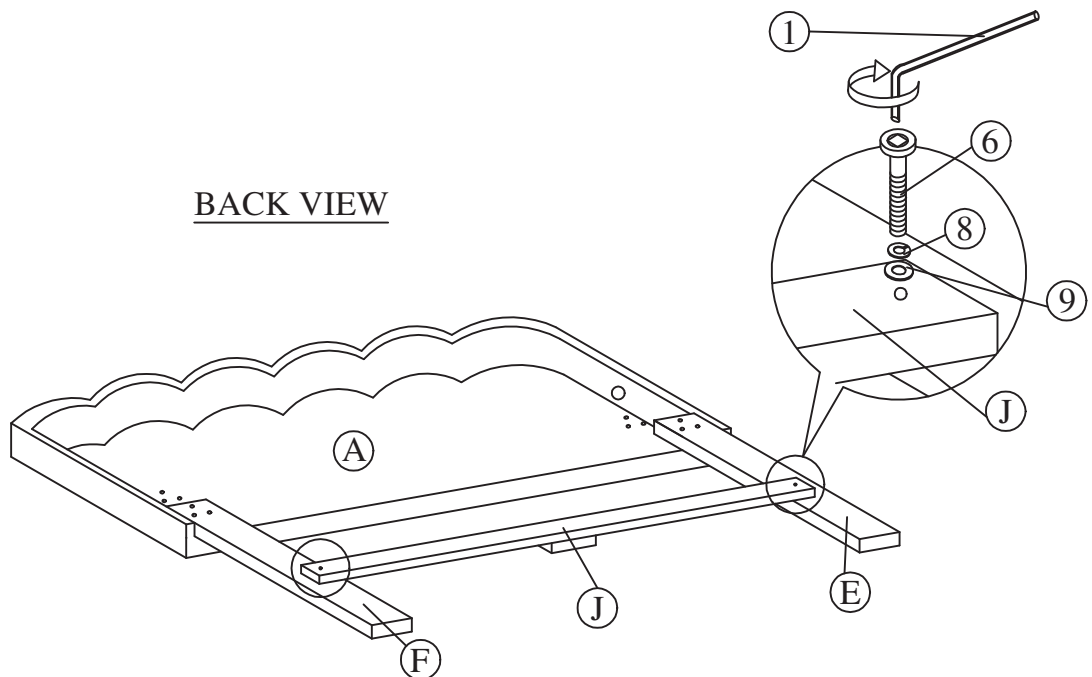

Attach the headboard leg support wood (J) to headboard legs (E/F) by using Bolt (6), Spring Washer (8), Flat Washer (9) with Allen Wrench (1).
FULLY TIGHTEN THE BOLT.

Step 4

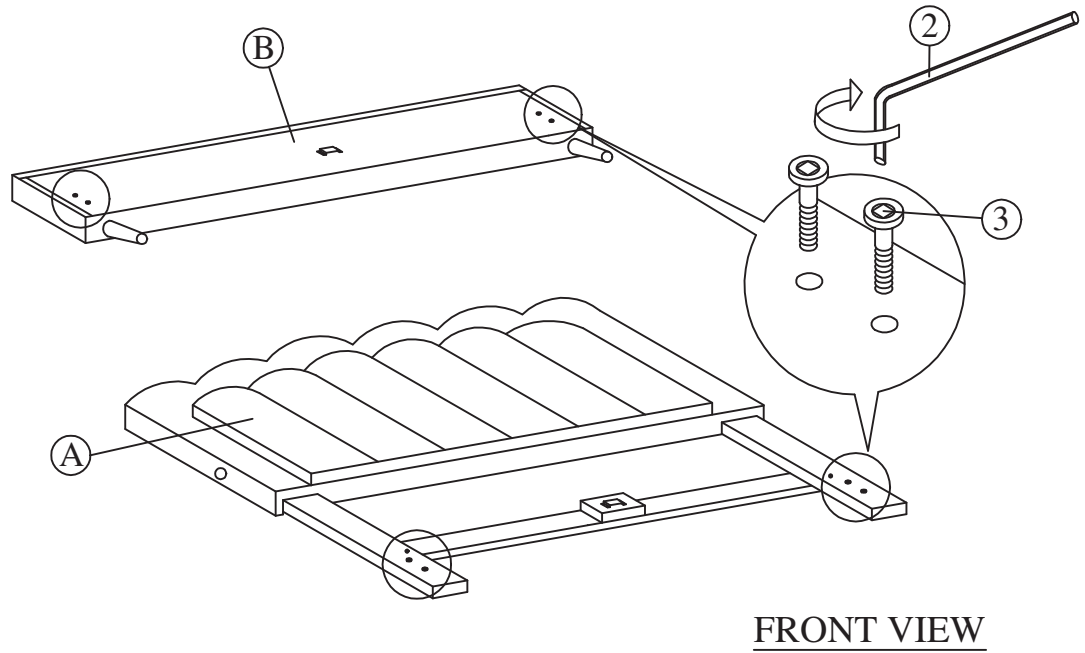

Attach the JCBB Bolt (3) to the headboard leg (E/F) and footboard (B) by using Allen Wrench (2).
DO NOT FULLY TIGHTEN THE BOLT.

Step 5

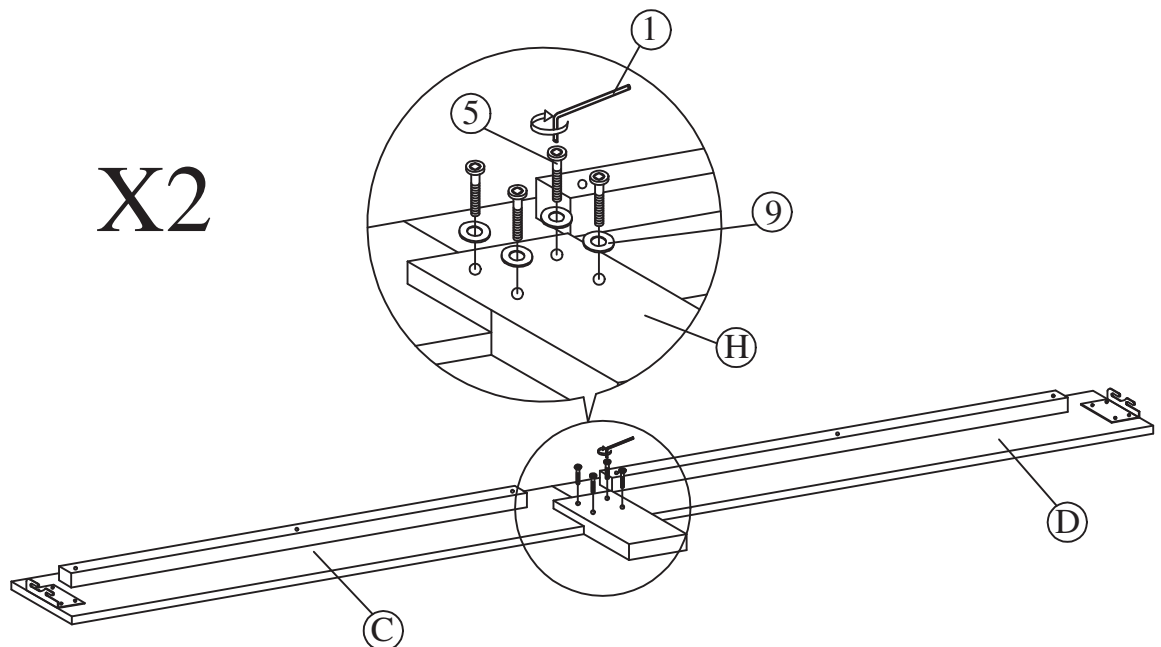

Attach the side rail leg (H) to the side rail (C/D) by using Bolt (5), Flat Washer (9) with Allen Wrench (1).
FULLY TIGHTEN THE BOLT.

Step 6

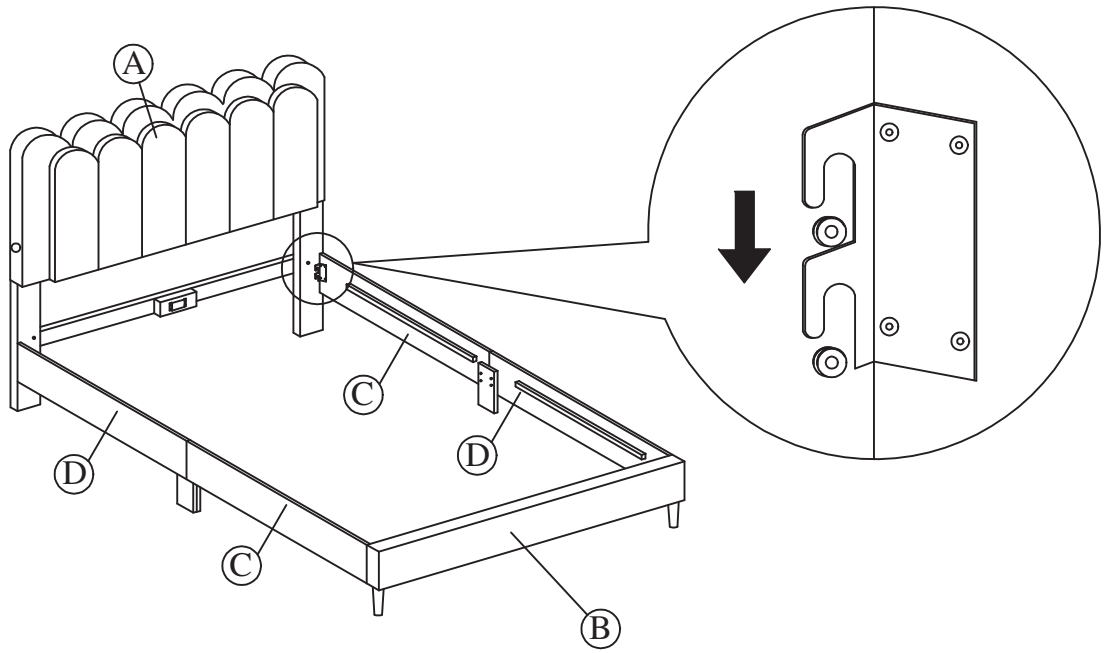

Attach side rail (C/D) to headboard (A) and footboard (B) by pushing the bracket down to fit it.

Step 7

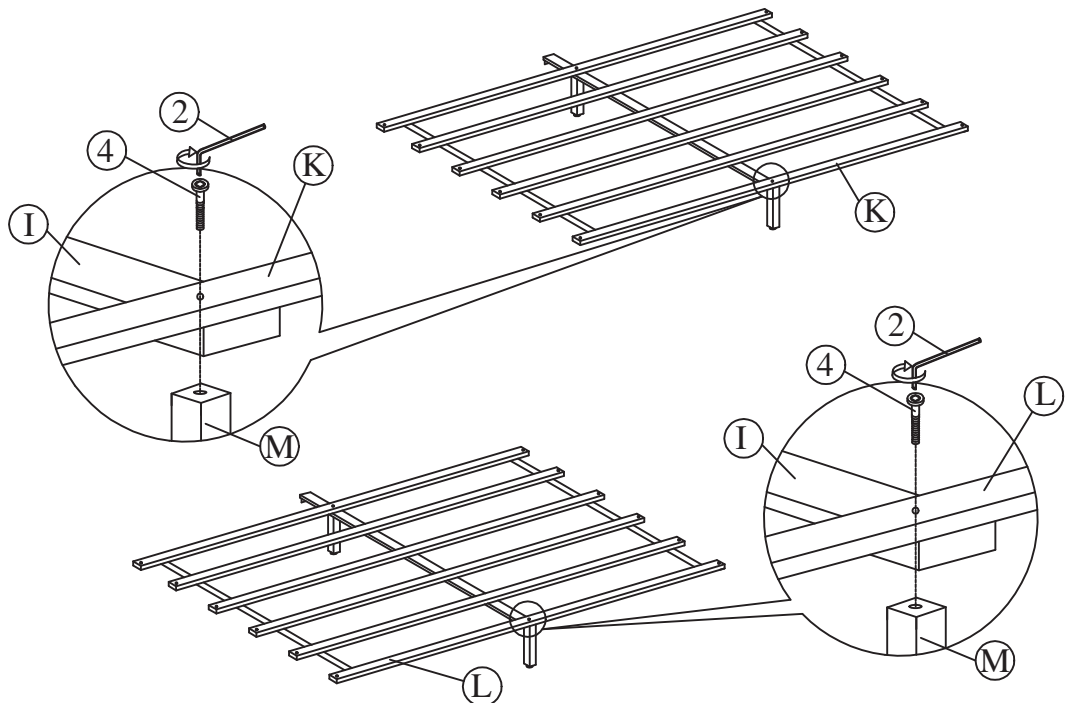

Attach the support legs (M) to the center rail (I) and slats (K/L) by using Bolt (4) with Allen Wrench (2).

FULLY TIGHTEN THE BOLT.

Step 8

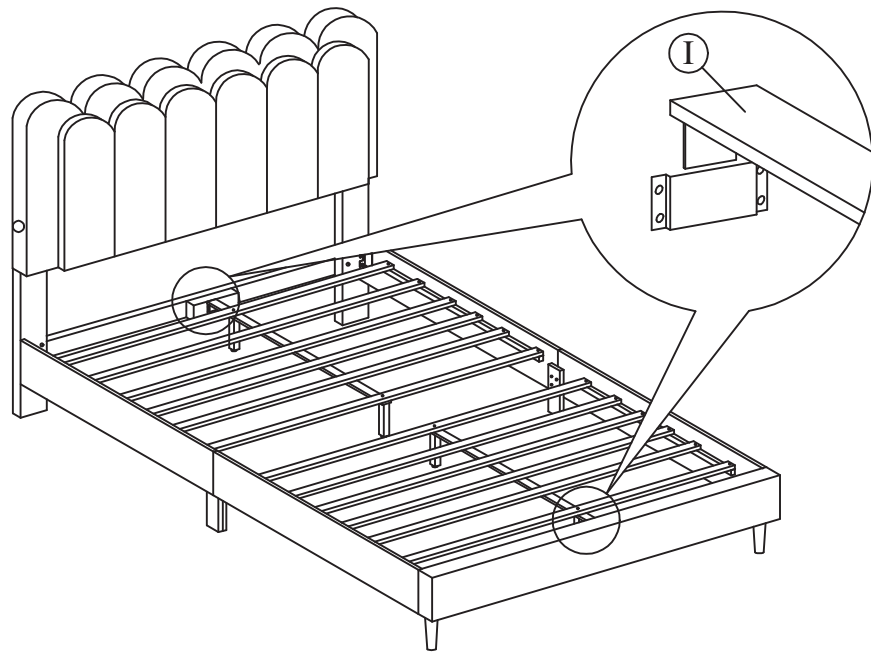

Slide the center rail (I) to the headboard leg support wood (J) and footboard (B).

Step 9

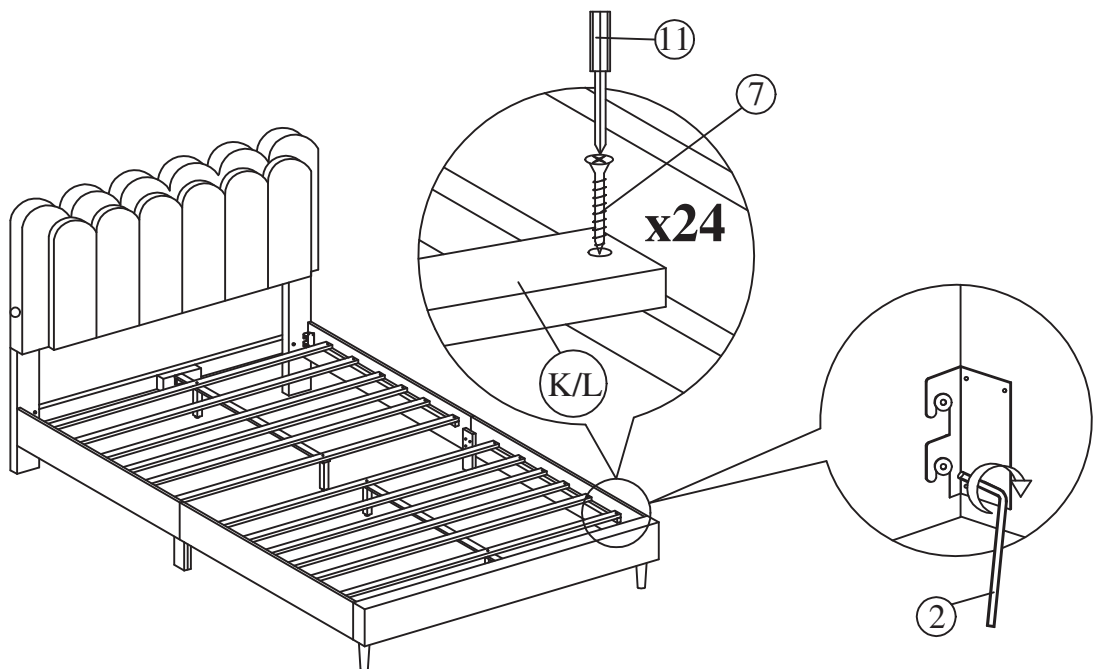

Tighten the 4 Corner with Allen Wrench (2). Install the bed slats to side rail. Tighten the slats with CSK screw. The distance of the slats should be sufficient to obtain desirable bed stability.

Step 10

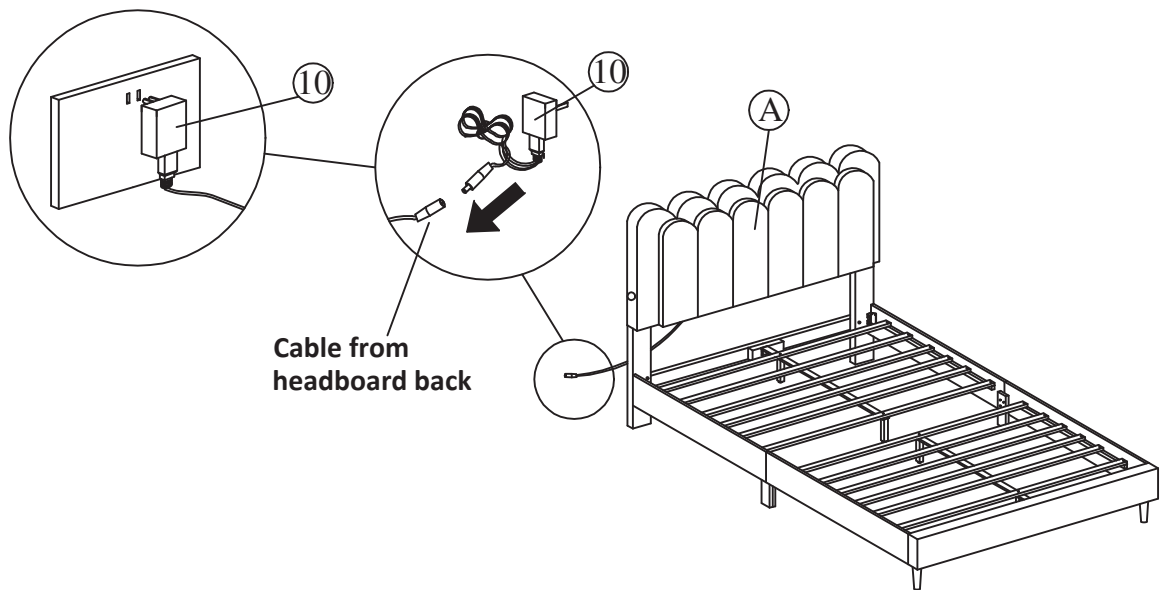

Install the plug (10) to the headboard back (A).

FC

"This device complies with Part 15 of the FCC Rules. Operation is subject to the following two conditions: (1) this device may not cause harmful interference, and (2) this device must accept any interference received, including interference that may cause undesired operation."