

ASSEMBLY INSTRUCTION



This instruction booklet contains important safety information, please read and keep for future reference.

This sofa collection works as modular sofa function, started as 2-seater sofa with left and right section, you can buy more components such as armless middle seat and ottoman to make it as 3-seater sofa, 4-seater sofa, L shape sectional, U shape sectional components to ensure all sofa section are well fit your living room area.

Measure your living room size before you make a decision to buy more components to ensure all sofa section are well fit your living room area.

You can decide to buy more components according to your living room size.

To ensure safe and satisfactory use of this product, please carefully read the below instructions beforehand.



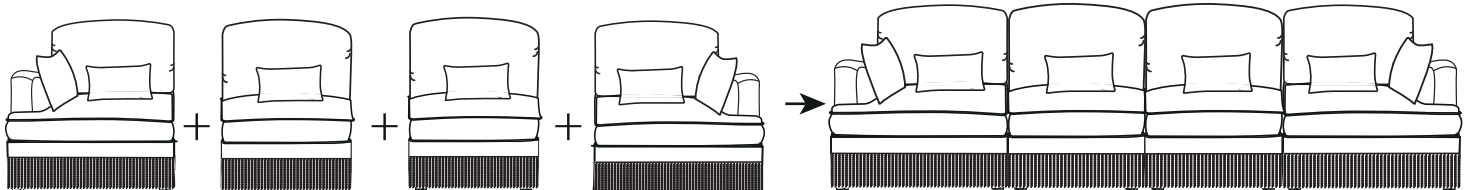
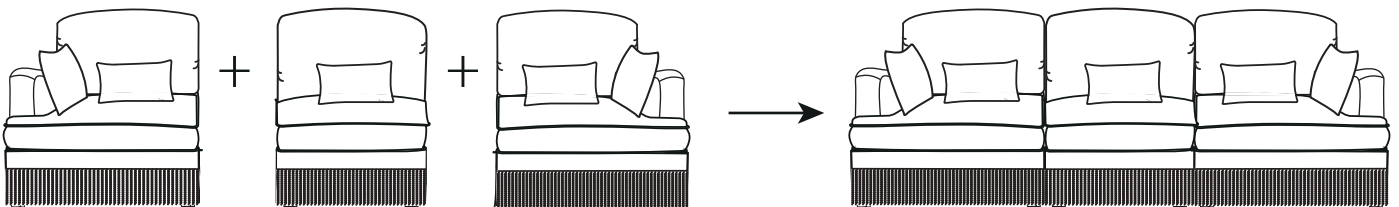
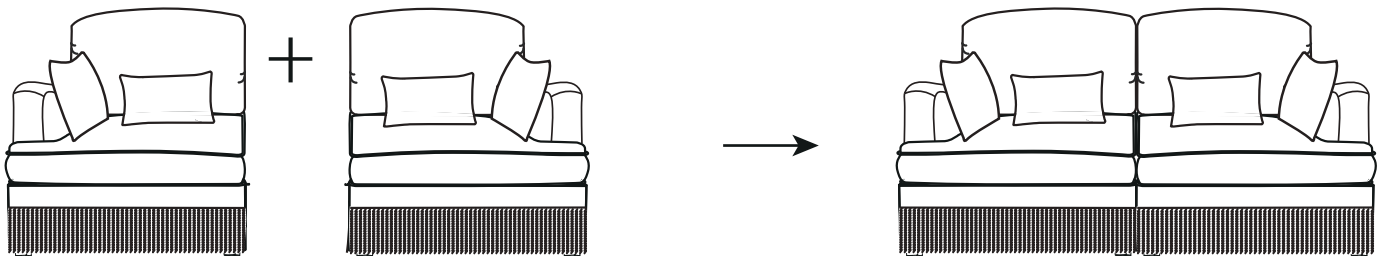

1. This sofa ships in several boxes, we recommend unpacking and starting assembly when several boxes are received.
2. Our cushions are vacuum packed for convenient shipping. Please allow 2-3 days for them to fully expand to their original shape and for any wrinkles to disappear.
3. In the event that a part is damaged or missing, no need to return the product, we will gladly help and ship your replacement parts free of charge.

Below are some guidelines for you how you can do mix and match.

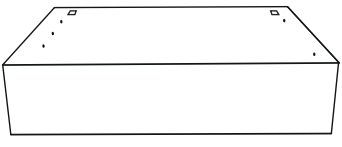
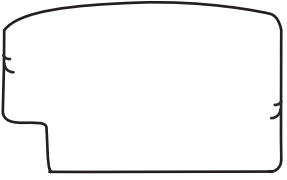
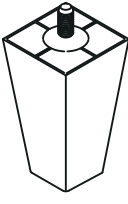
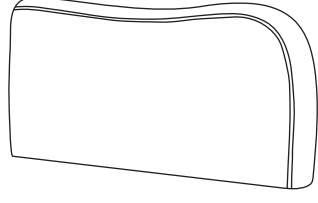
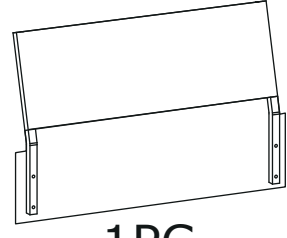
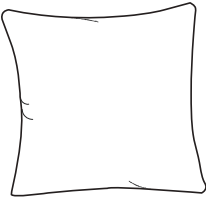
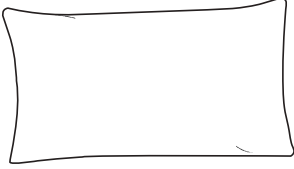
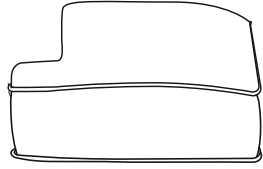
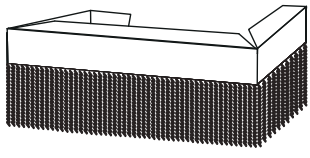
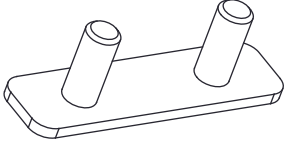

IF YOU BUY 2 SEATER SOFA
please follow below assembly instruction

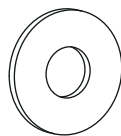
Parts List (Box 1)

- | | | | | |
|--|--|--|--|--|
| <p>A Left seat frame</p>  <p>1PC</p> | <p>D Back cushion</p>  <p>1PC</p> | <p>F Leg</p>  <p>4PCS</p> | | |
| <p>G Armrest</p>  <p>1PC</p> | <p>H Backrest</p>  <p>1PC</p> | <p>I Armrest Pillow</p>  <p>1PC</p> | | |
| <p>J Pillow</p>  <p>1PC</p> | <p>L Left seat cushion</p>  <p>1PC</p> | <p>O Left seat frame cover</p>  <p>1PC</p> | | |
| <p>K Connector</p>  <p>1PC</p> | <p>R M8X60MM Bolt</p>  <p>4PCS</p> | <p>S M8X40MM Bolt</p>  <p>3PCS</p> | <p>T Washer</p>  <p>7PCS</p> | <p>U Allen key</p>  <p>1PC</p> |

IF YOU BUY 2 SEATER SOFA
please follow below assembly instruction

Parts List (Box 2)

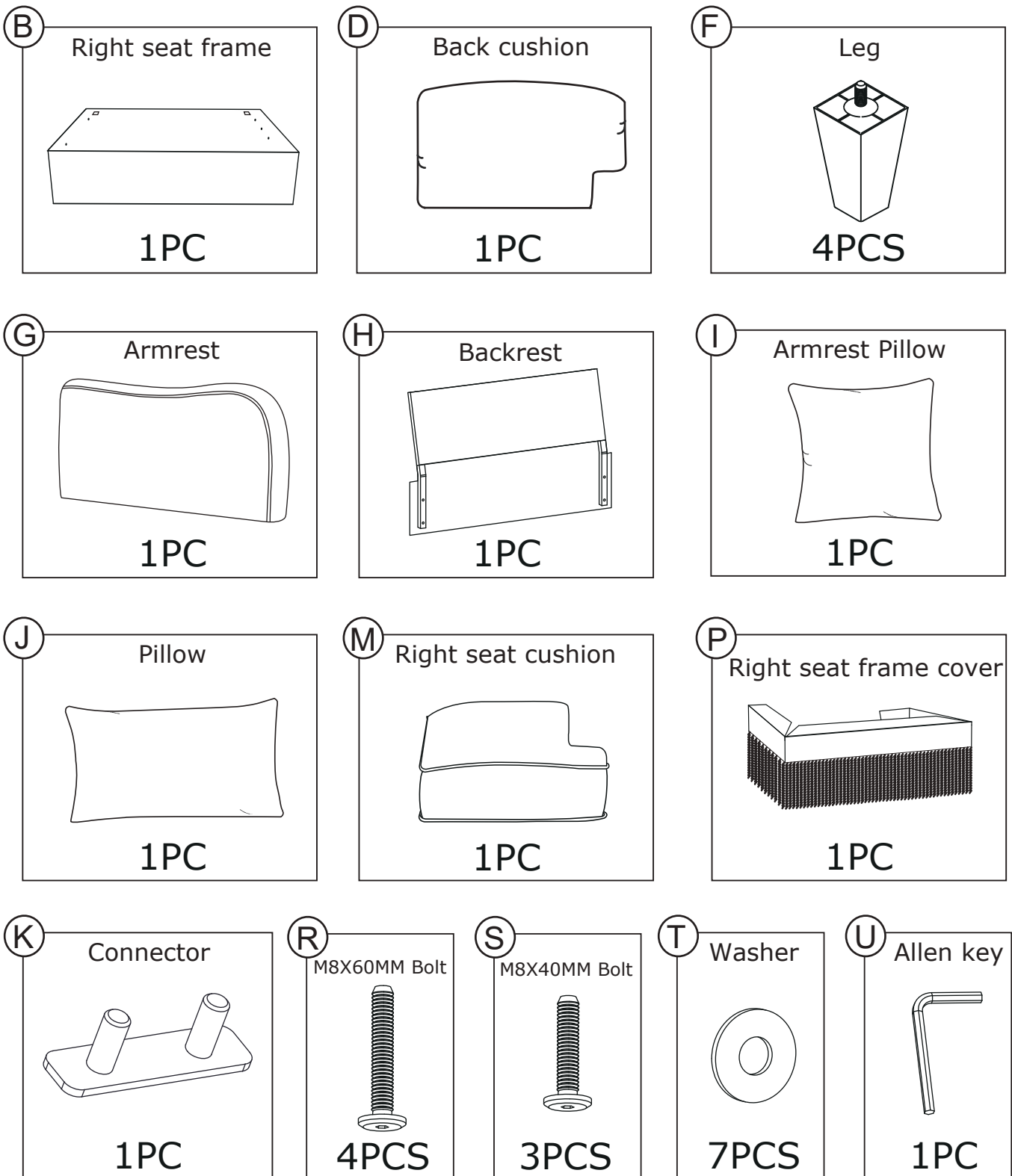

ASSEMBLY STEPS

STEP 1 Assemble the Legs (F) to the Left seat frame (A).

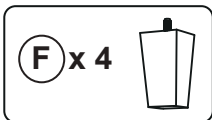
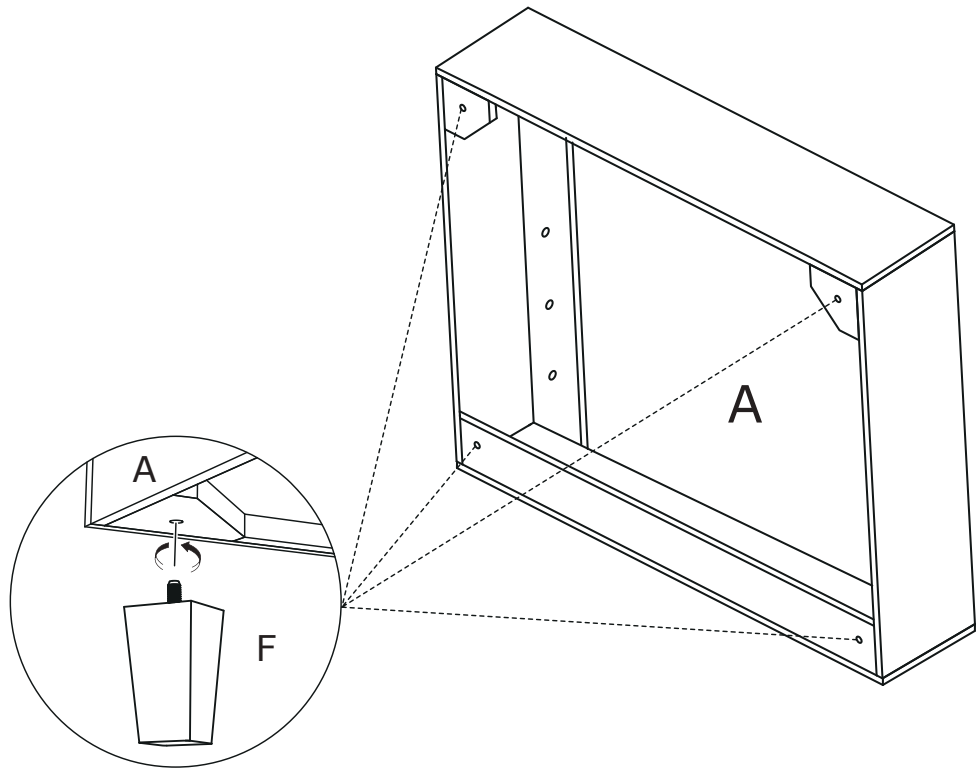

STEP 2 Assemble the Legs (F) to the Right seat frame (B).

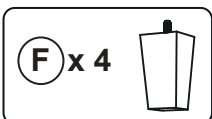
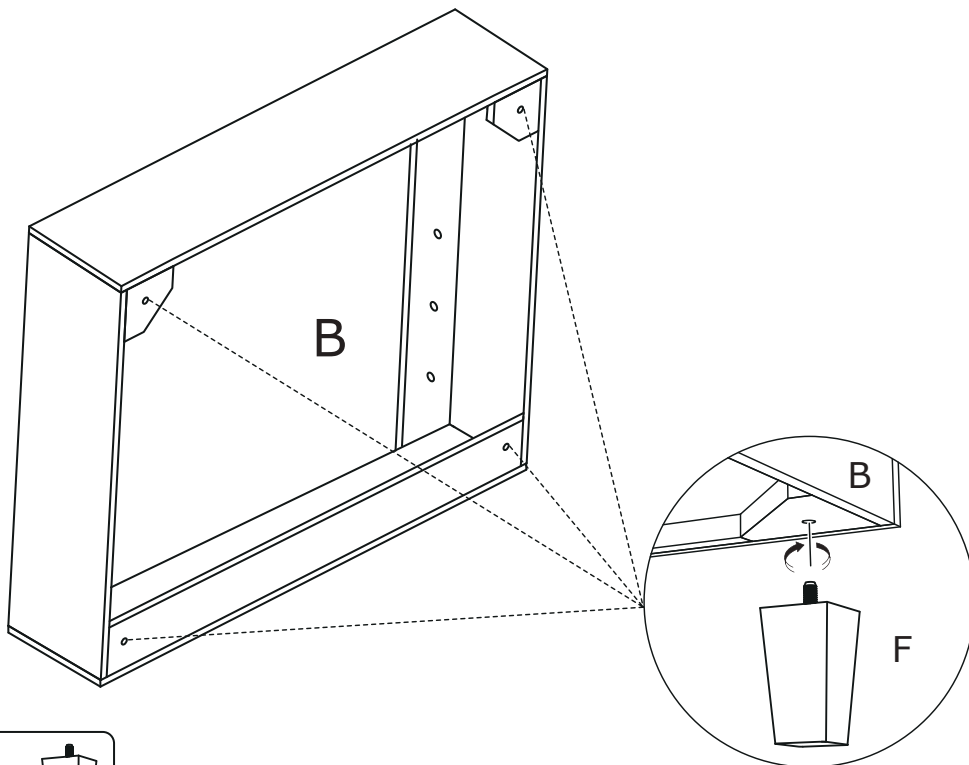

STEP 3 Insert the Left seat frame cover (O) into the Left seat frame (A).

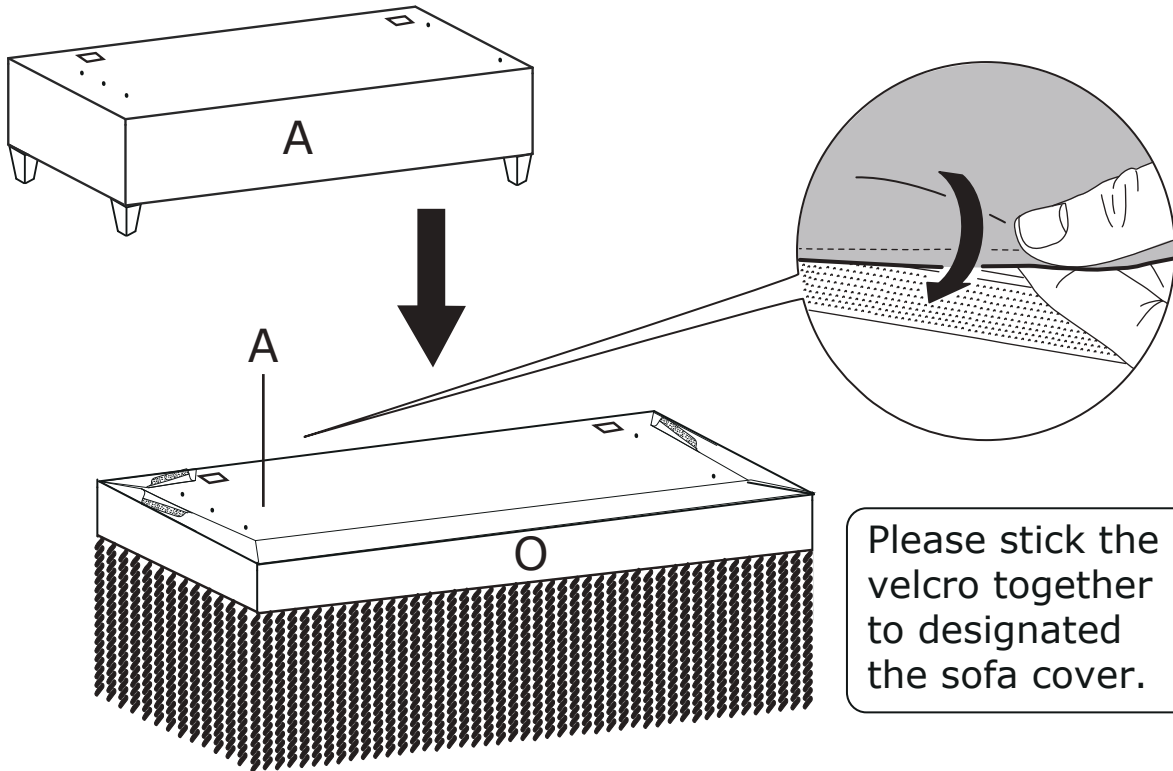

STEP 4 Insert the Right seat frame cover (P) into the Right seat frame (B).

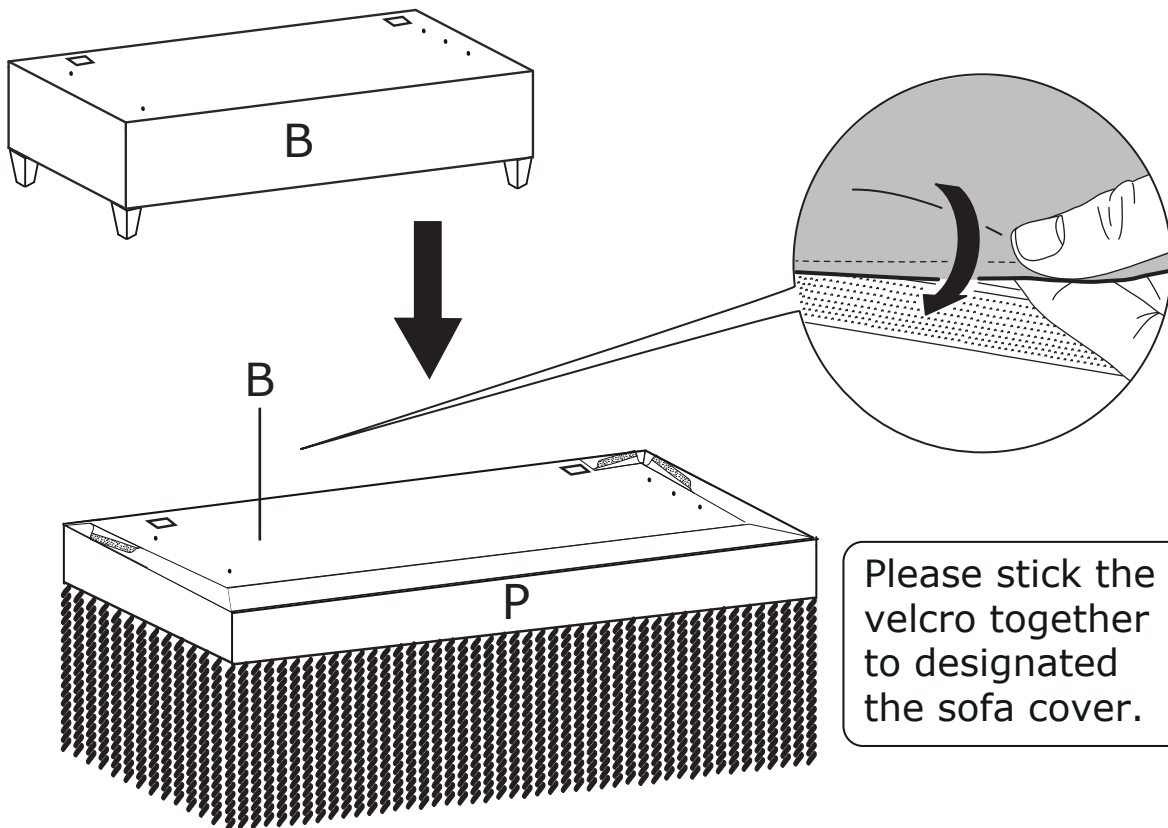

STEP 5 Assemble the armrest (G) to the Left seat frame (A) with Washers (T) and Bolts (S).

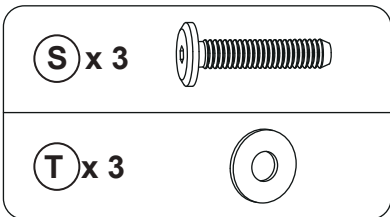
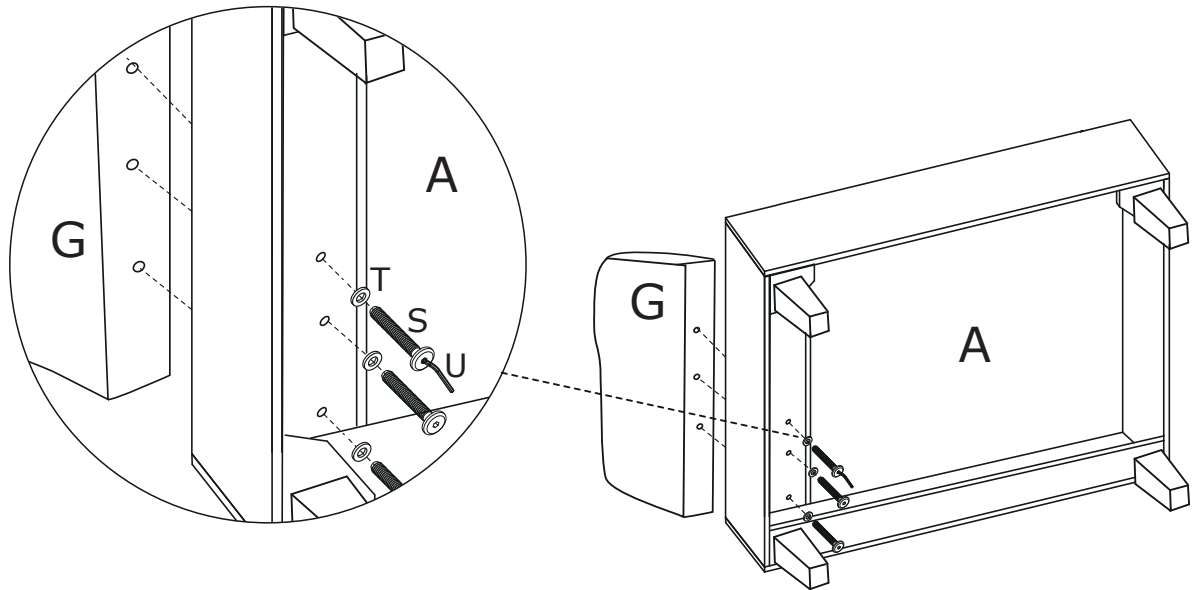

STEP 6 Assemble the armrest (G) to the Right seat frame (B) with Washers (T) and Bolts (S).

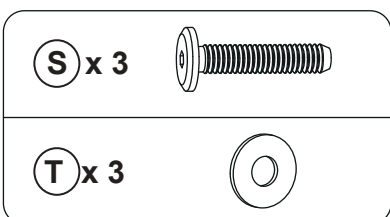
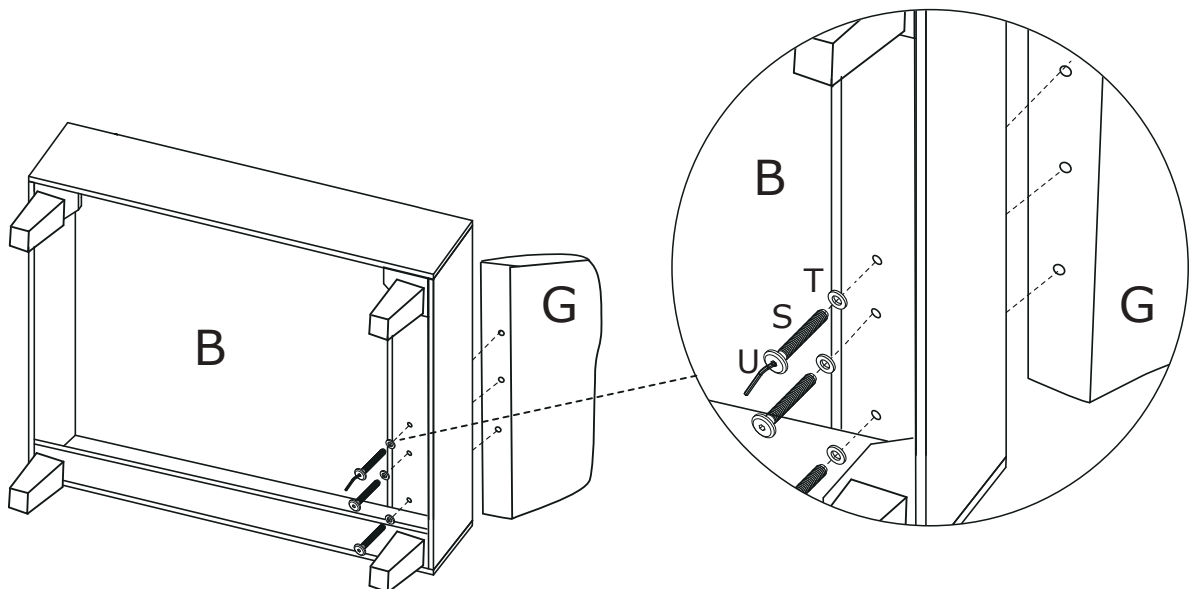

STEP 7 Insert the Backrest (H) into the designated holes, using Washers (T) and Bolts (R) to 70% tightness, and then tighten all bolts on the seat.

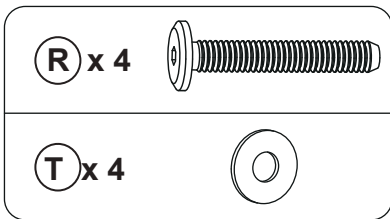
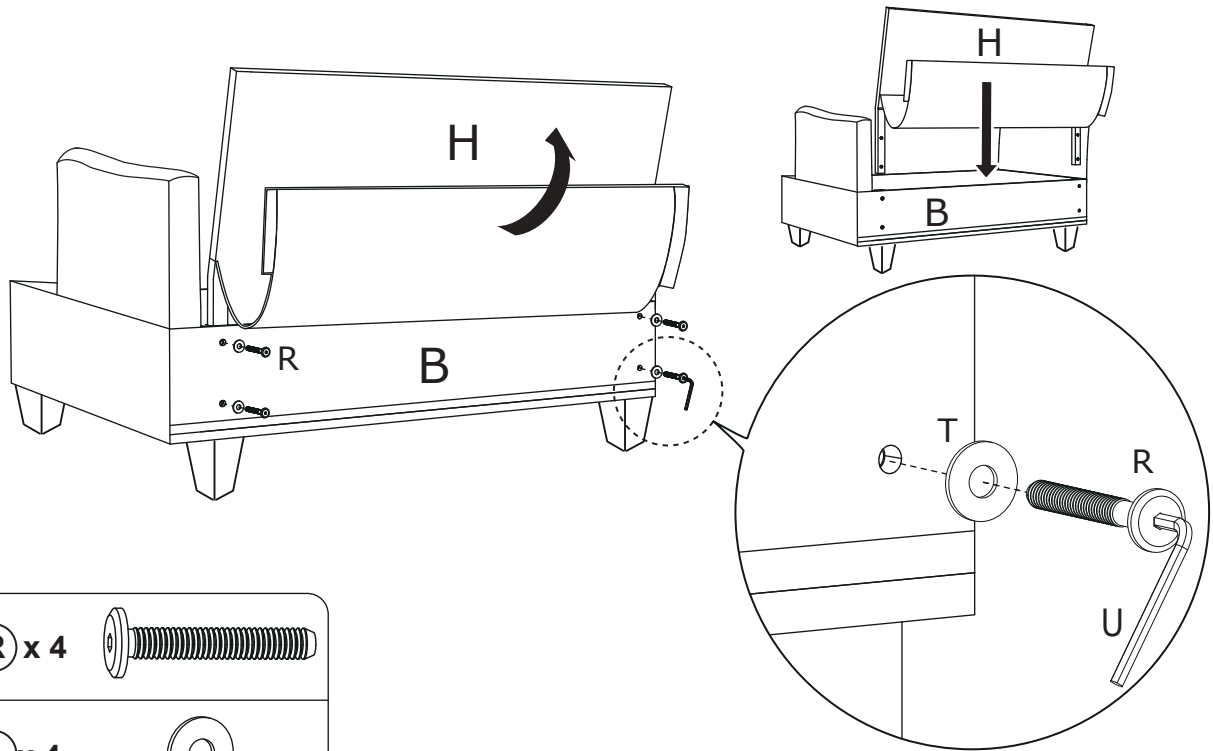

STEP 8 Insert the Backrest (H) into the designated holes, using Washers (T) and Bolts (R) to 70% tightness, and then tighten all bolts on the seat.

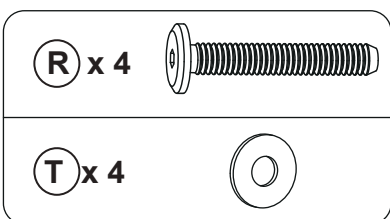
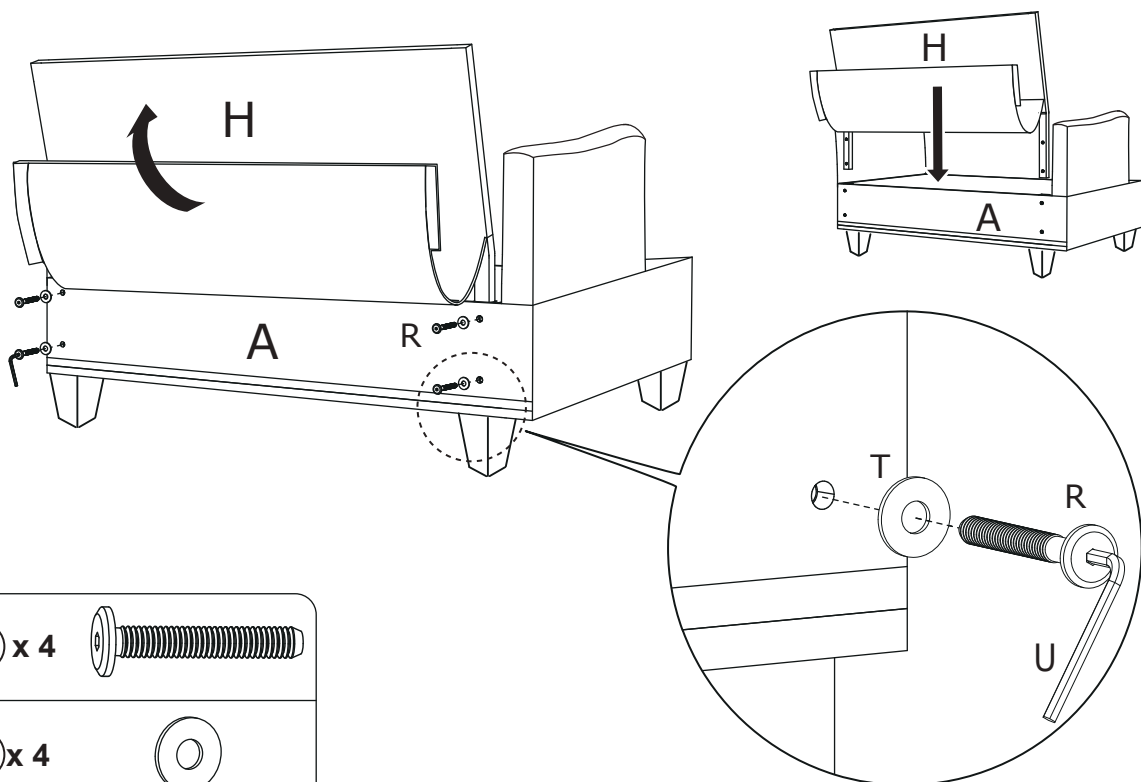

STEP 9 Insert the Connector (K) into the designated holes, then the sofa connected together.

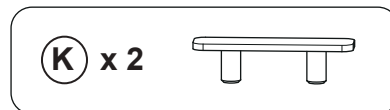
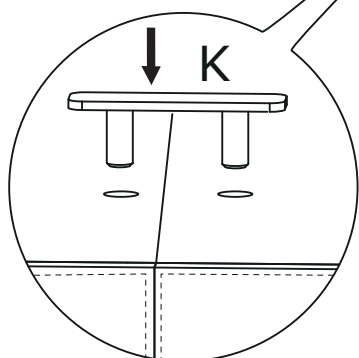
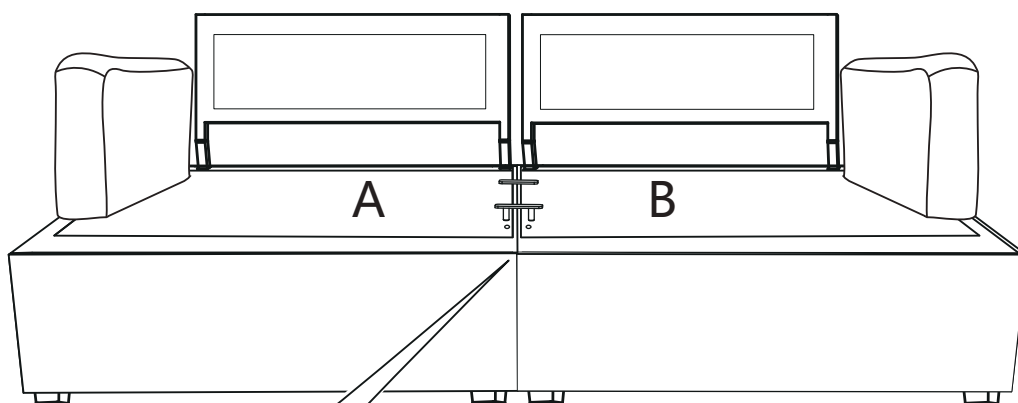
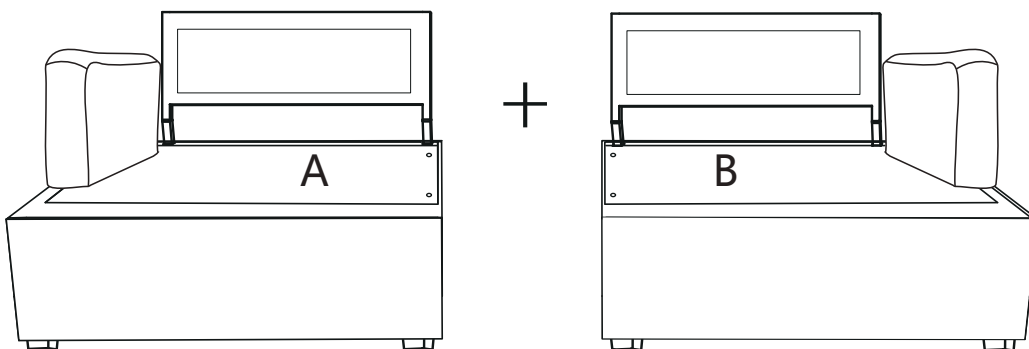

STEP 10 The cushion is packed by vacuum compression. After cutting the package, it rebounds quickly within 4 hours. If the fabric has wrinkles, it will basically disappear after standing for 72 hours. If still has wrinkles after 72 hours, steam with iron is workable.

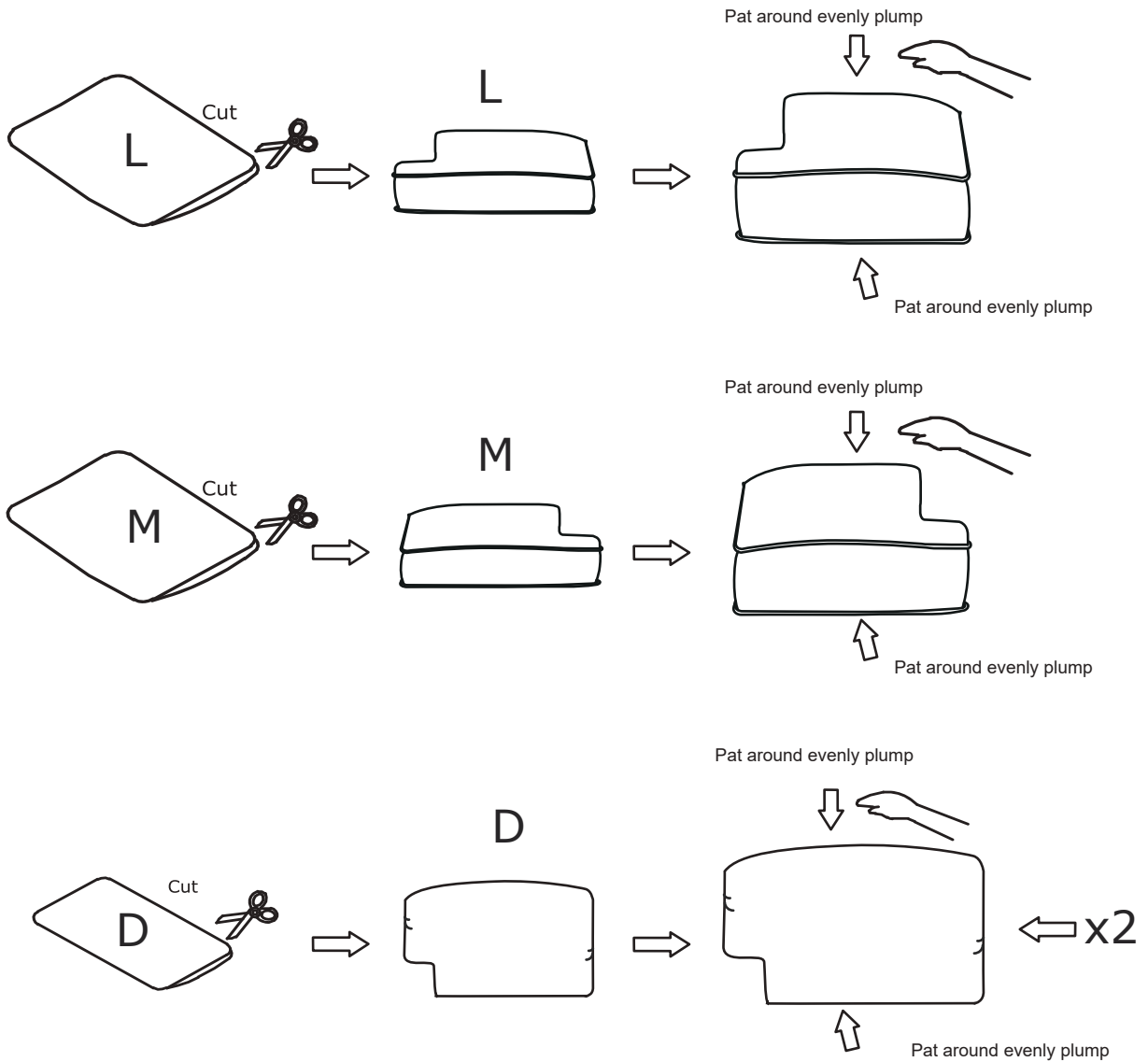

STEP 11 Put Left seat cushion (L), Right seat cushion (M), Back cushion(D) , Armrest pillow (I) and Pillow (J) to the Sofa.

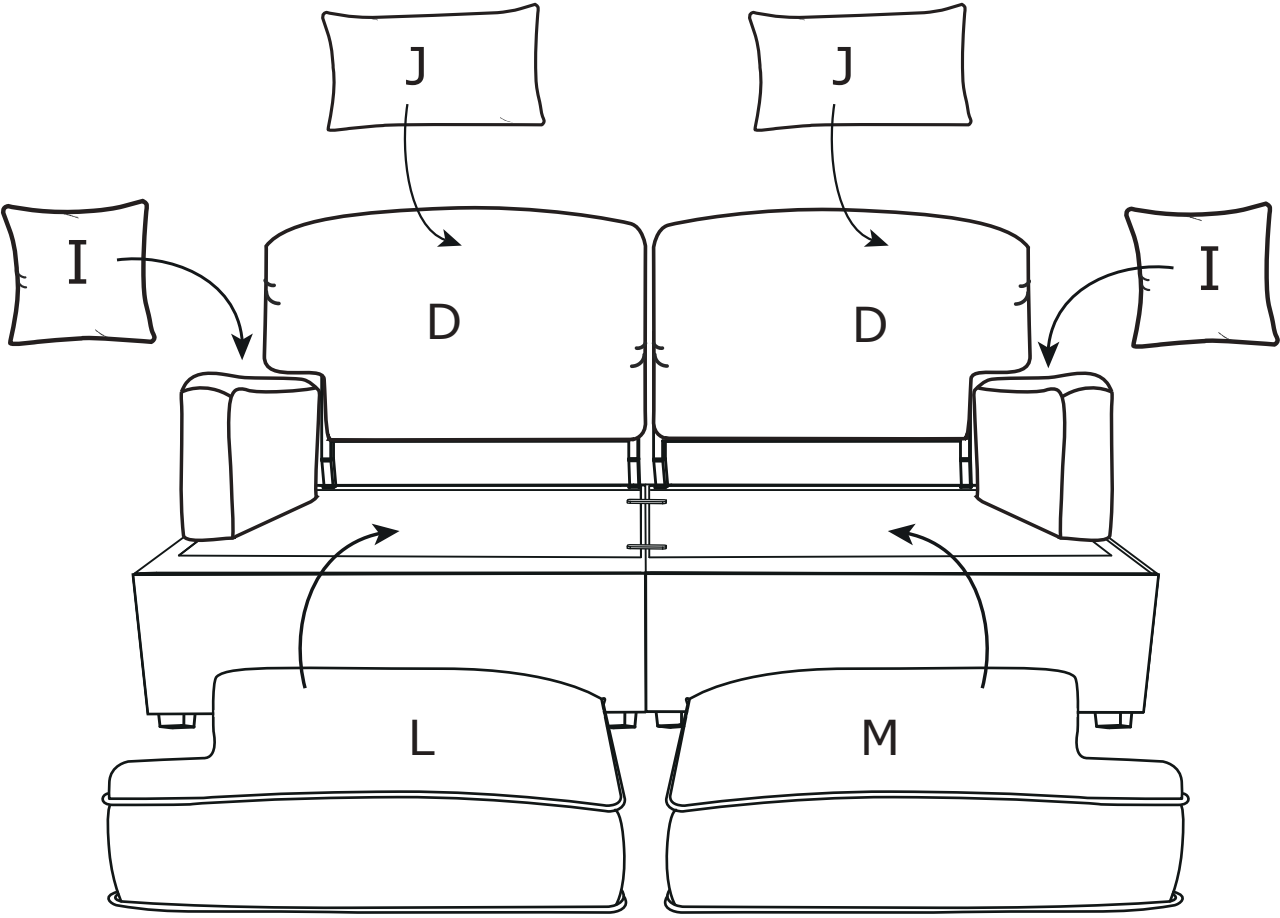



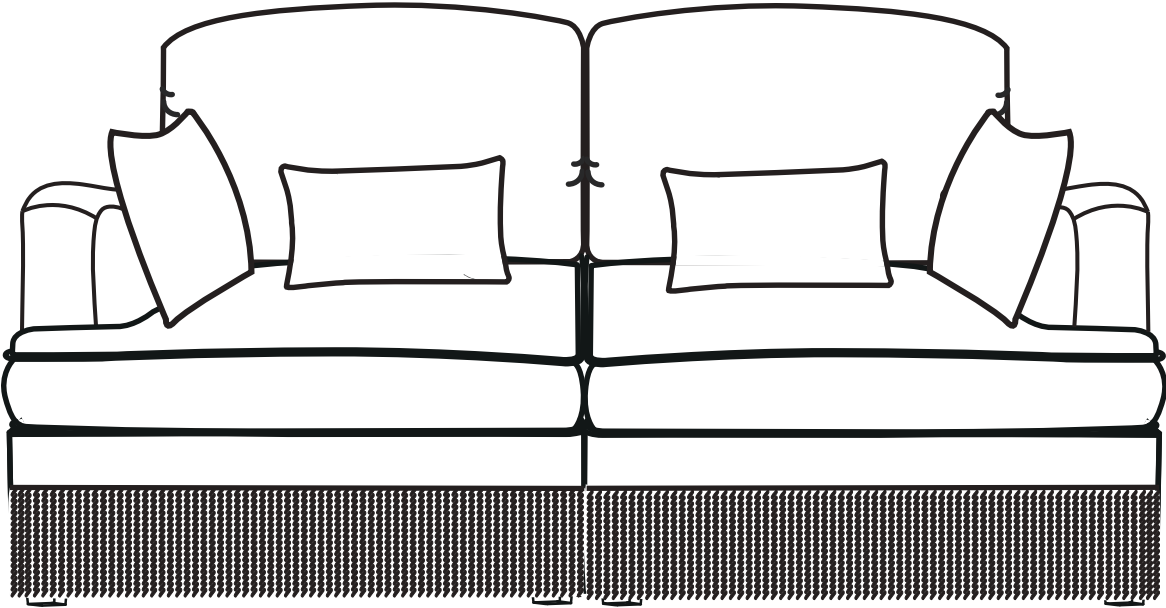

STEP 12 Completed.

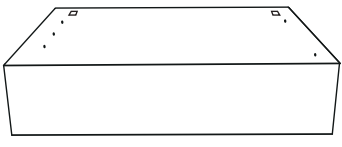
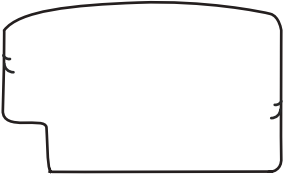
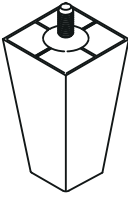
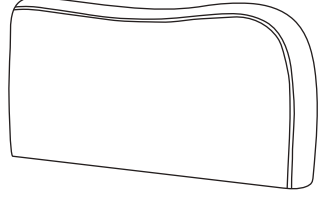
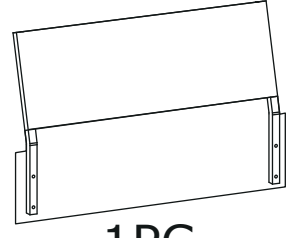
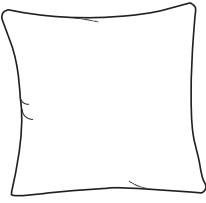
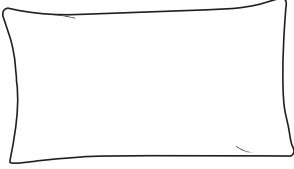
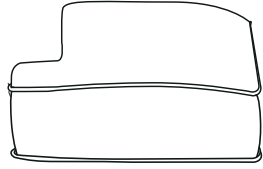
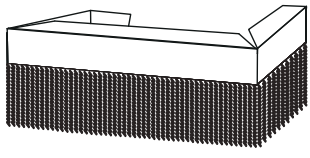
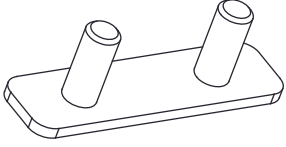

IF YOU BUY 3 SEATER SOFA
please follow below assembly instruction

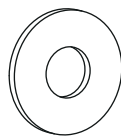
Parts List (Box 1)

- | | | | | |
|---|---|---|---|---|
| <p>A Left seat frame</p>  <p>1PC</p> | <p>D Back cushion</p>  <p>1PC</p> | <p>F Leg</p>  <p>4PCS</p> | | |
| <p>G Armrest</p>  <p>1PC</p> | <p>H Backrest</p>  <p>1PC</p> | <p>I Armrest pillow</p>  <p>1PC</p> | | |
| <p>J Pillow</p>  <p>1PC</p> | <p>L Left seat cushion</p>  <p>1PC</p> | <p>O Left seat frame cover</p>  <p>1PC</p> | | |
| <p>K Connector</p>  <p>1PC</p> | <p>R M8X60MM Bolt</p>  <p>4PCS</p> | <p>S M8X40MM Bolt</p>  <p>3PCS</p> | <p>T Washer</p>  <p>7PCS</p> | <p>U Allen key</p>  <p>1PC</p> |

IF YOU BUY 3 SEATER SOFA
please follow below assembly instruction

Parts List (Box 2)

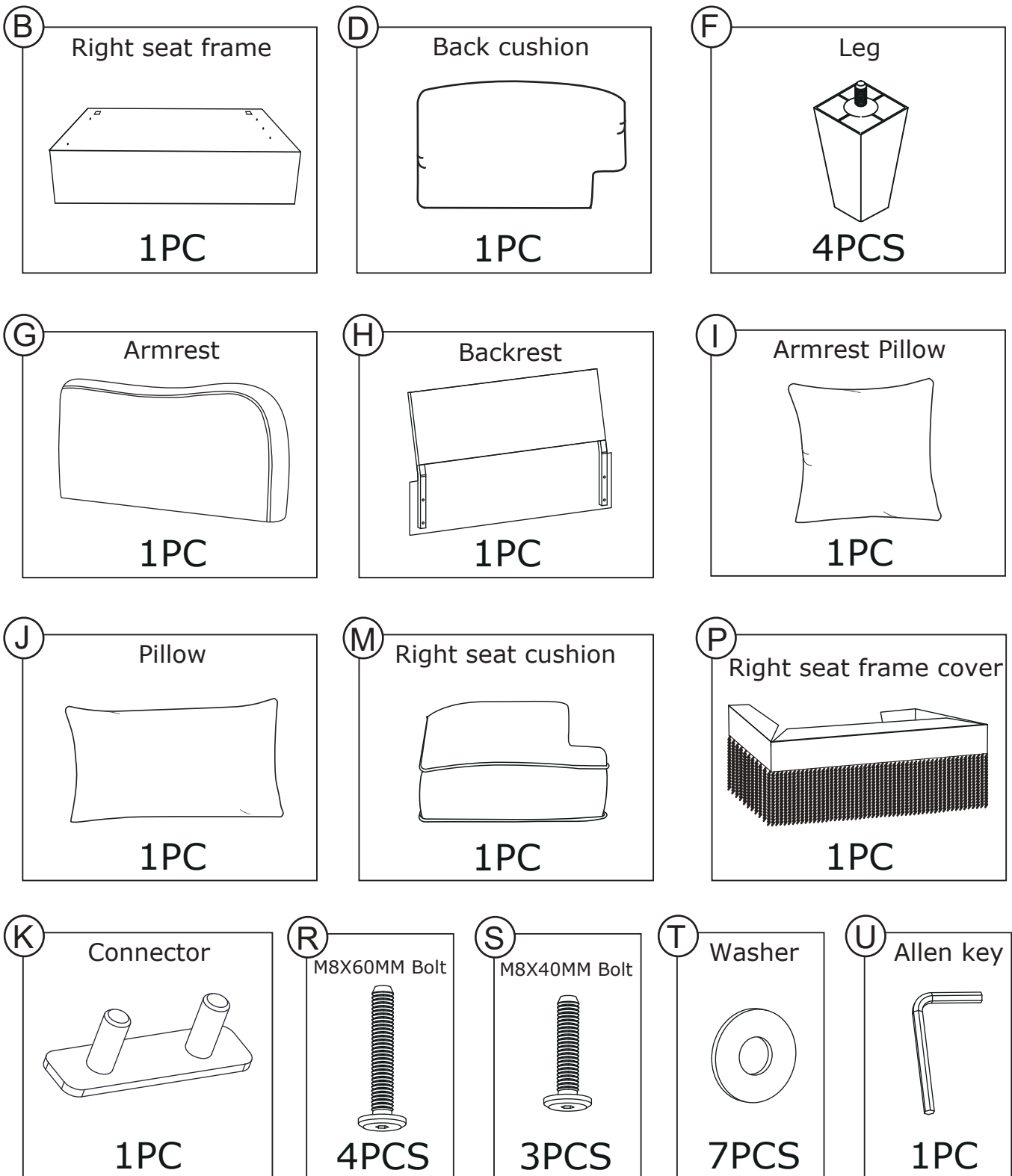

IF YOU BUY 3 SEATER SOFA
please follow below assembly instruction

Parts List (Box 3)

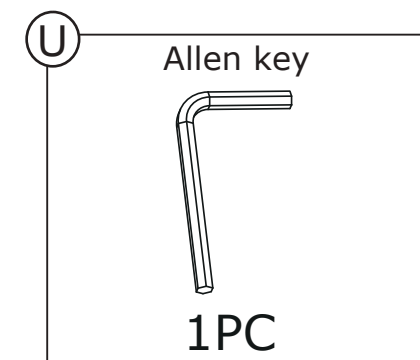
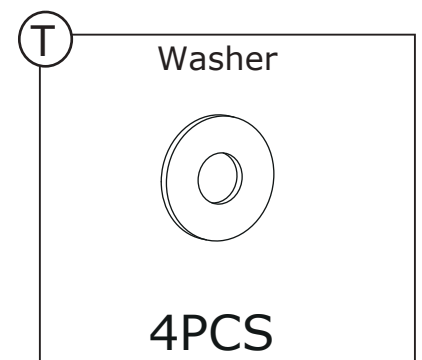
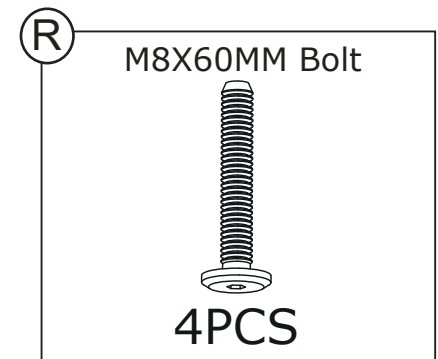
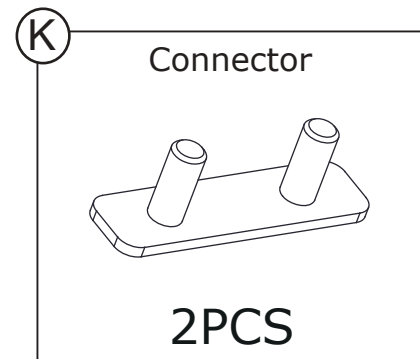
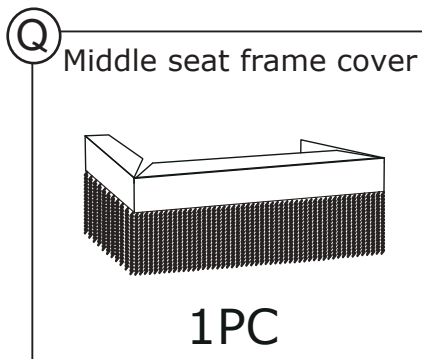
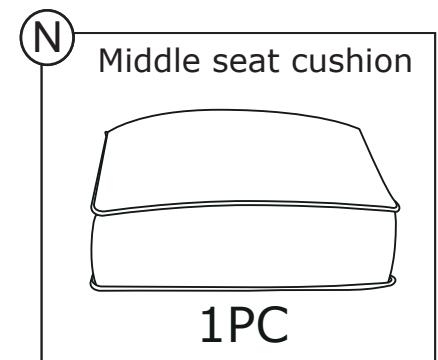
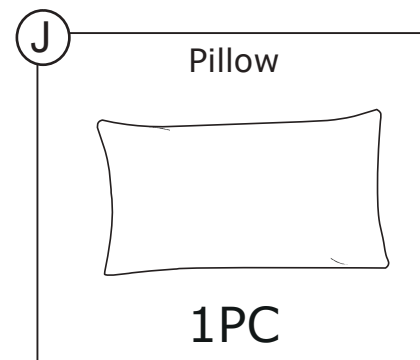
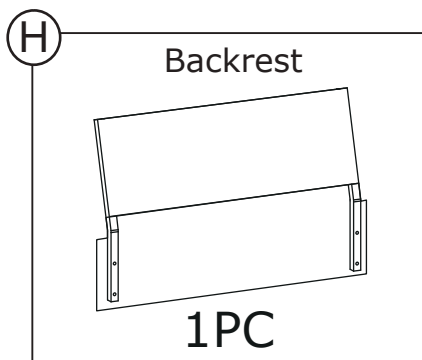
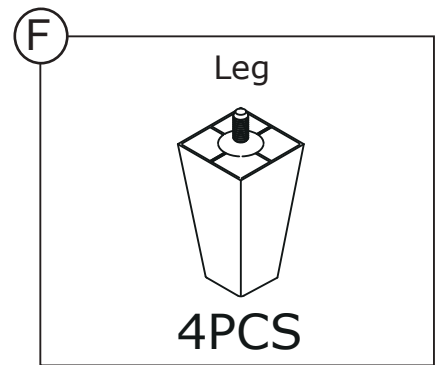
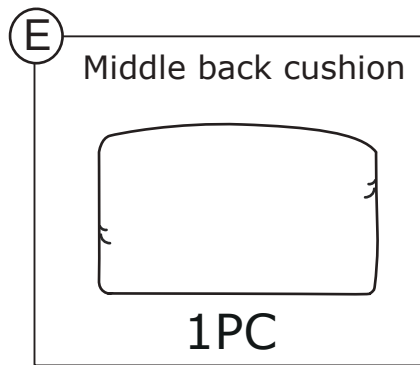
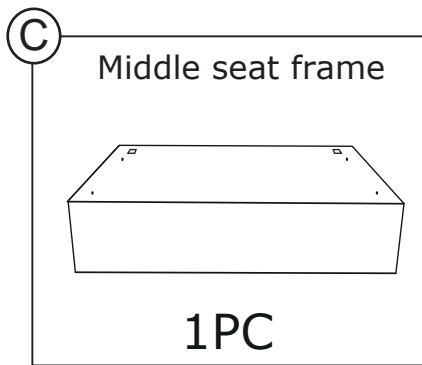

Note: Please retain all boxes until you are certain that your product isn't damaged and that you do not wish to return it. Disposal of boxes may prevent our ability to resolve your request.

ASSEMBLY STEPS

STEP 1 Assemble the Legs (F) to the Left seat frame (A).

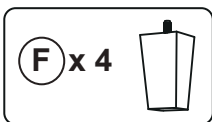
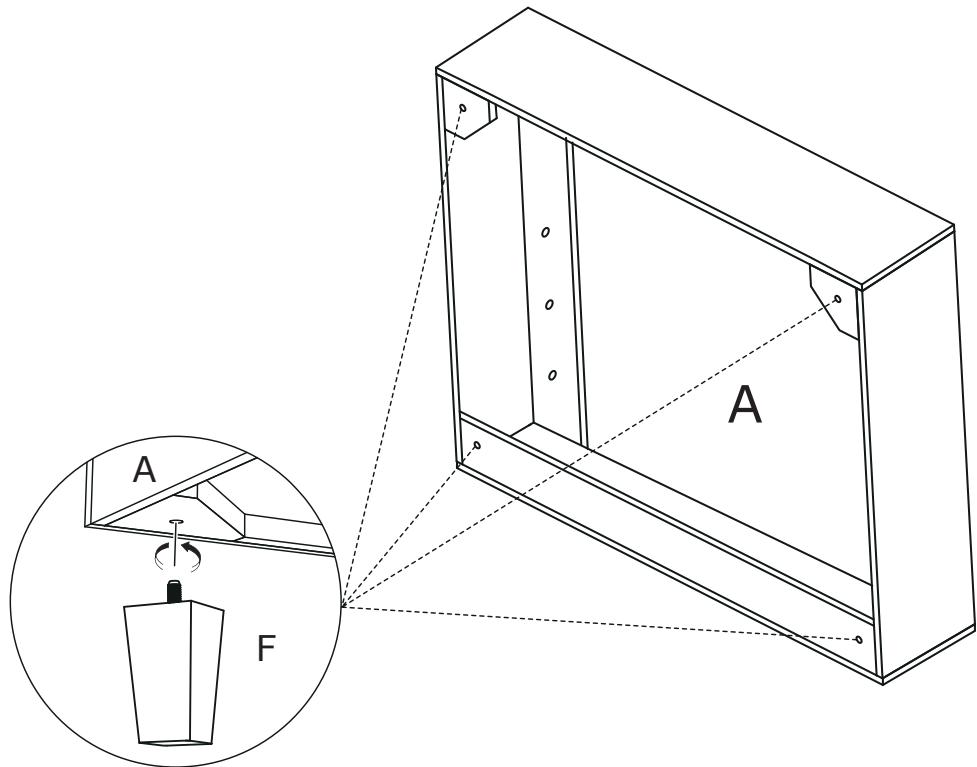

STEP 2 Assemble the Legs (F) to the Right seat frame (B).

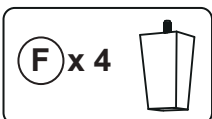
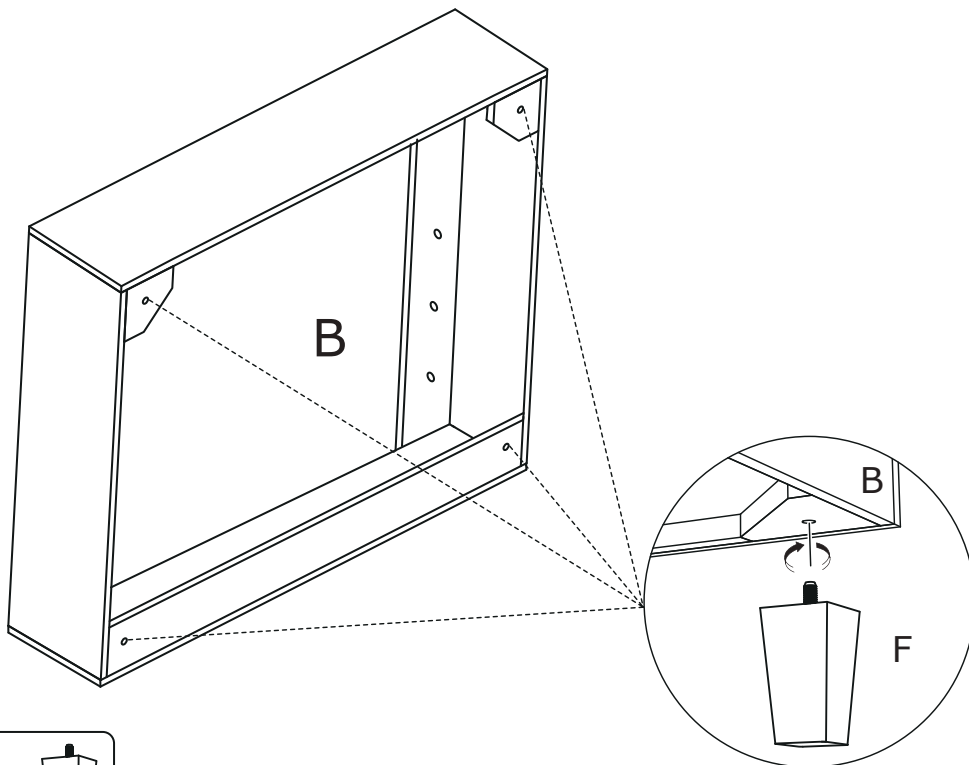

STEP 3 Insert the Left seat frame cover (O) into the Left seat frame (A).

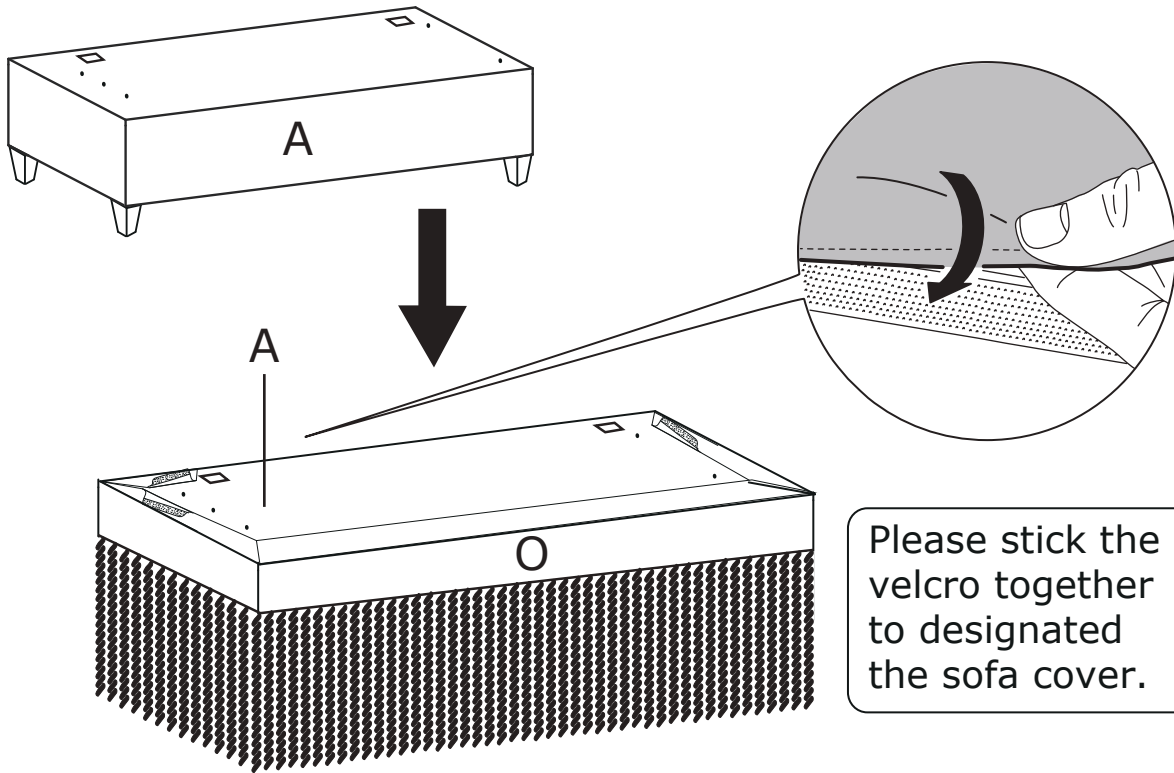

STEP 4 Insert the Right seat frame cover (P) into the Right seat frame (B).

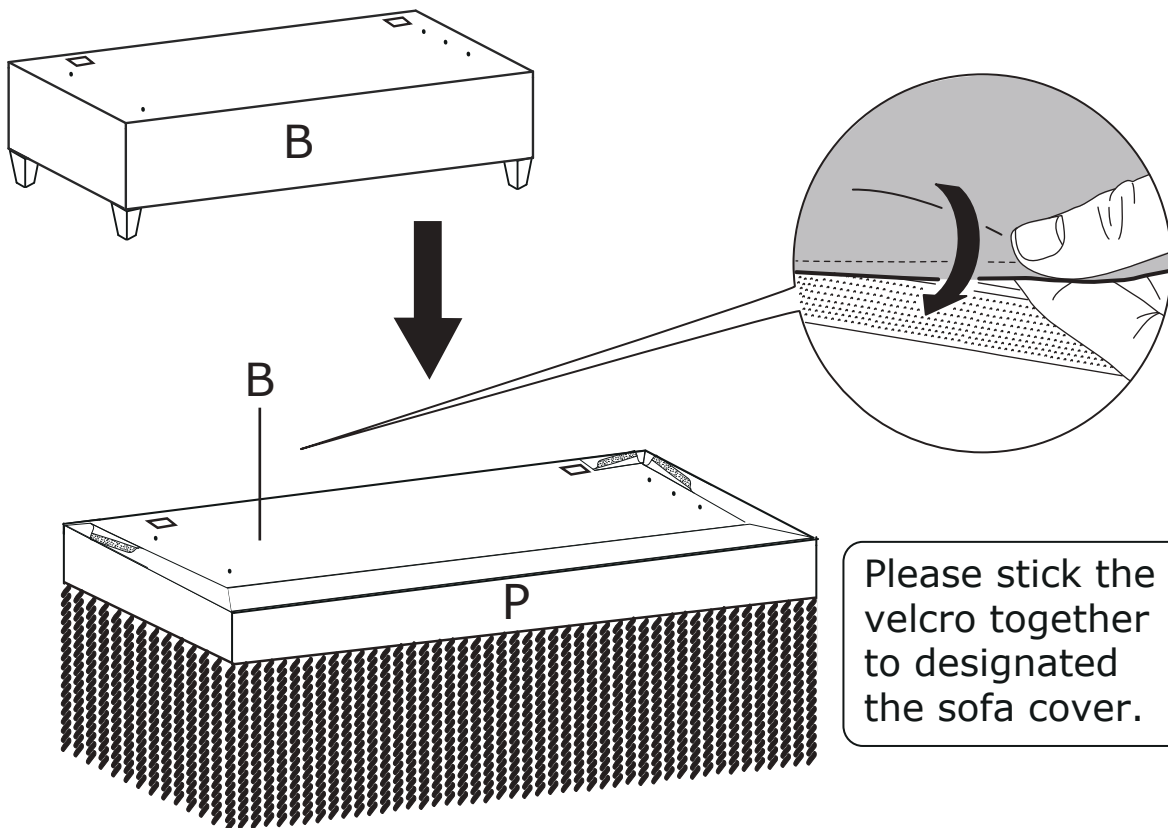

STEP 5 Assemble the armrest (G) to the Left seat frame (A) with Washers (T) and Bolts (S).

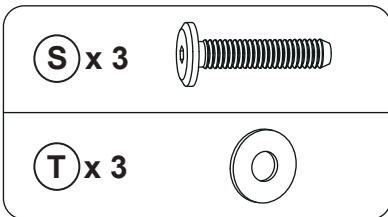
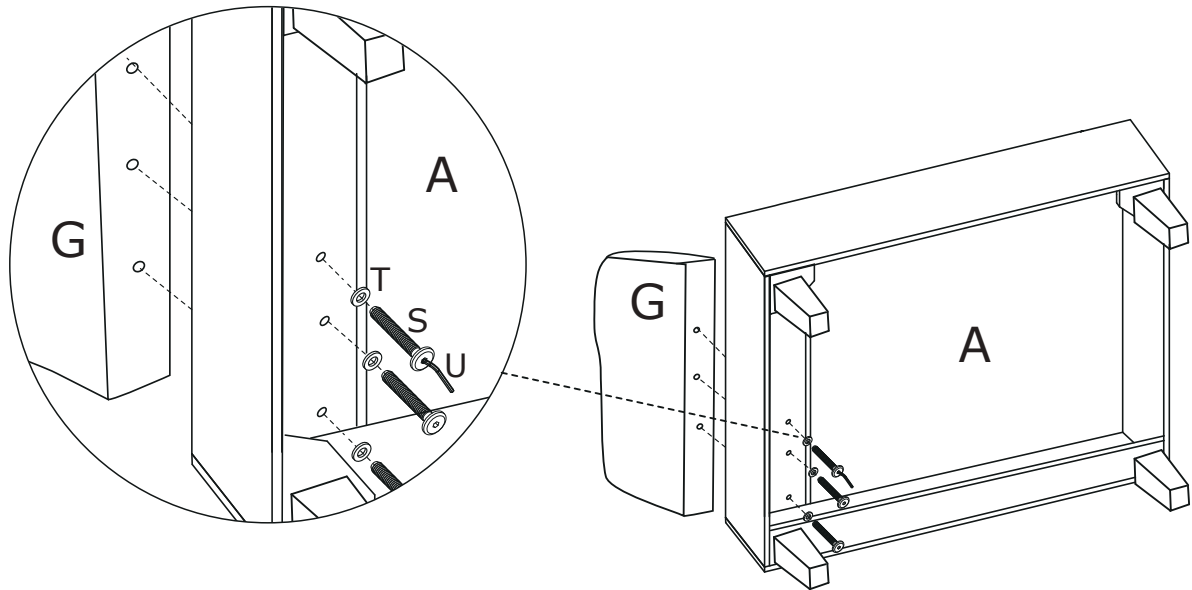

STEP 6 Assemble the armrest (G) to the Right seat frame (B) with Washers (T) and Bolts (S).

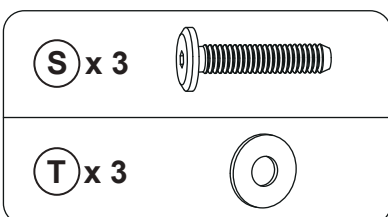
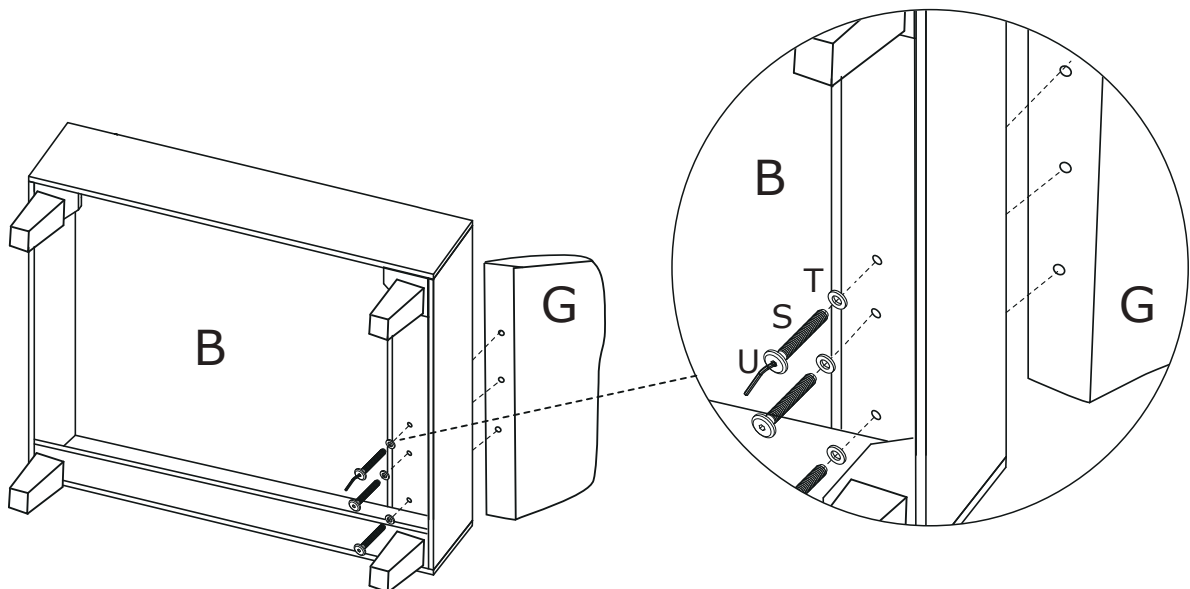

STEP 7 Insert the Backrest (H) into the designated holes, using Washers (T) and Bolts (R) to 70% tightness, and then tighten all bolts on the seat.

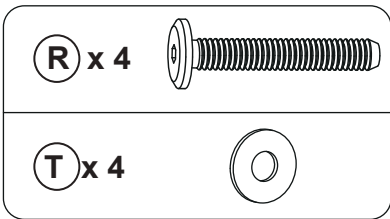
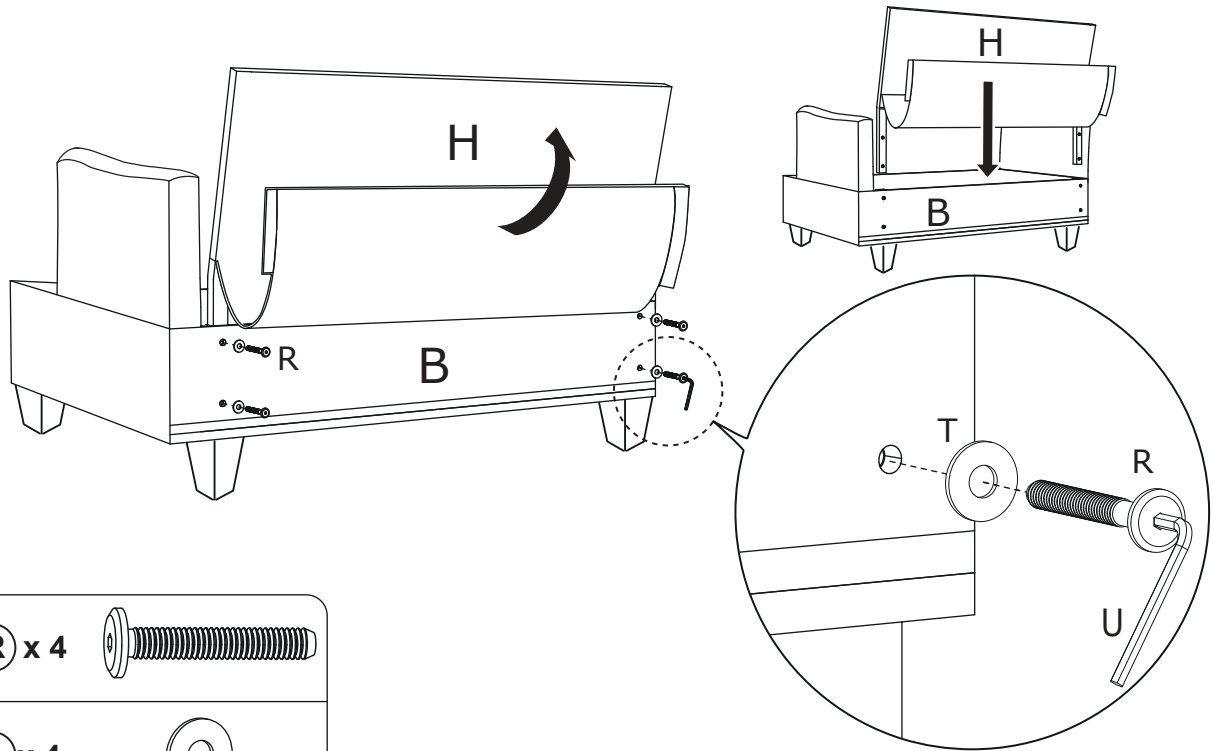

STEP 8 Insert the Backrest (H) into the designated holes, using Washers (T) and Bolts (R) to 70% tightness, and then tighten all bolts on the seat.

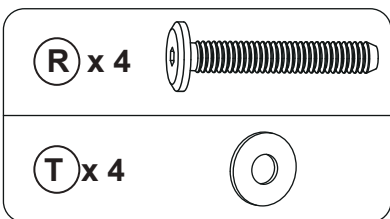
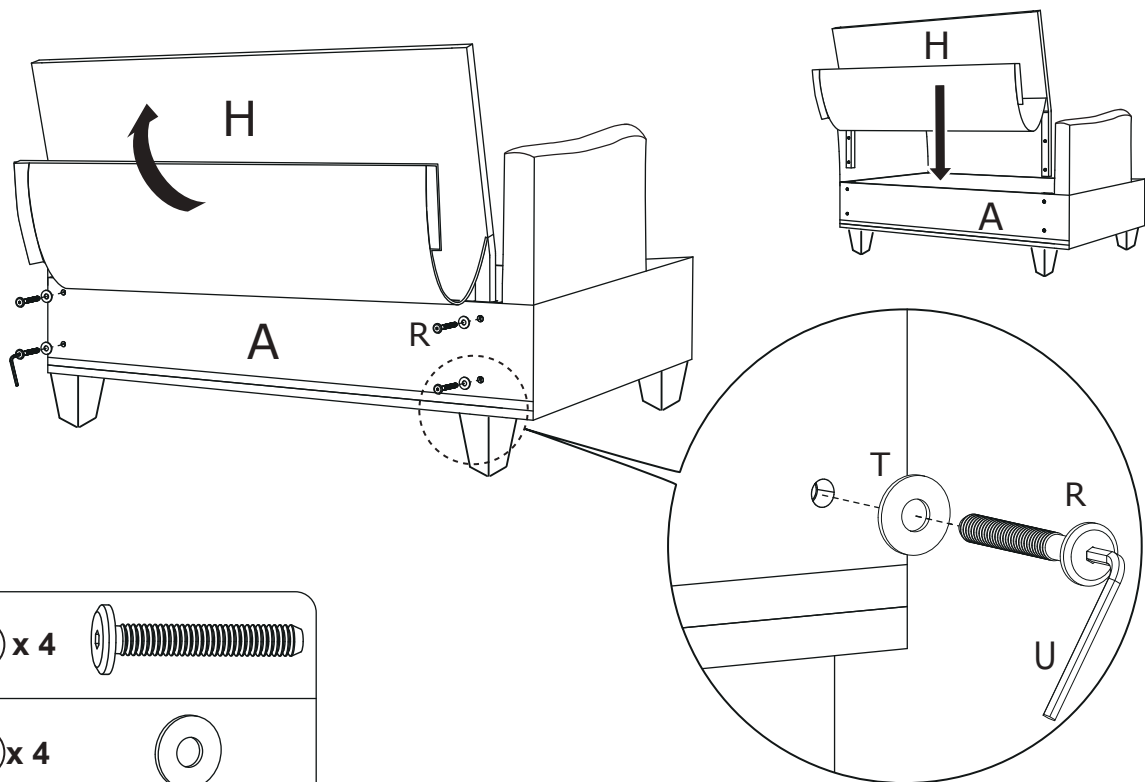

STEP 9 Assemble the Legs (F) to the Middle seat frame (C).

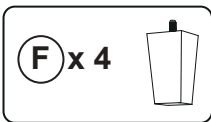
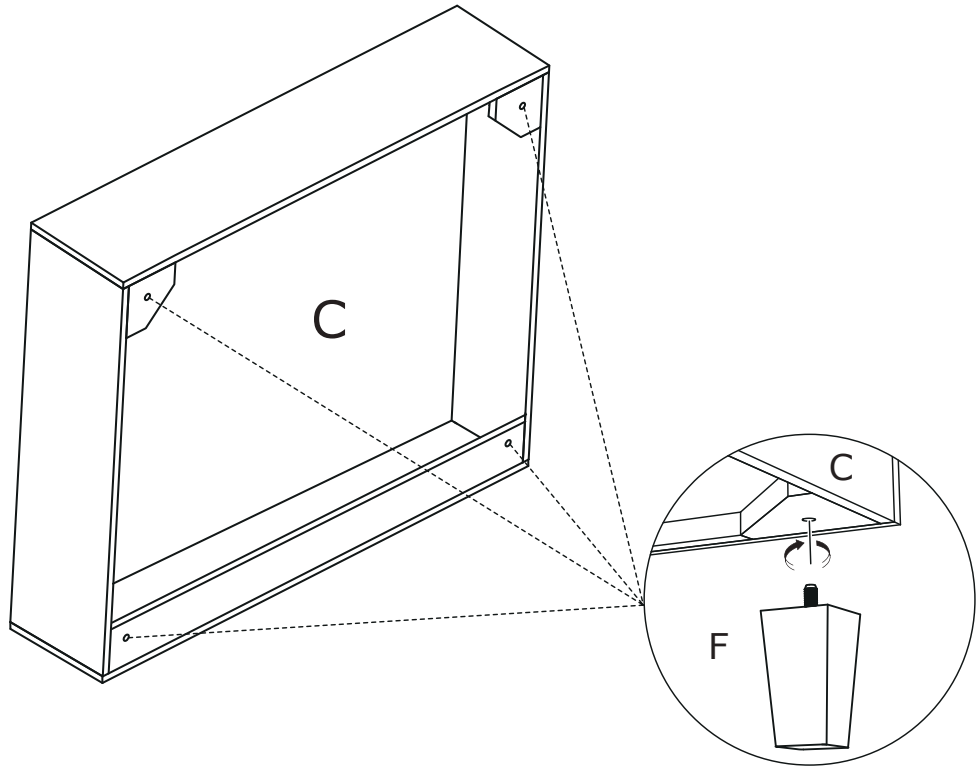

STEP 10 Insert the Middle seat frame cover (Q) into the Middle seat frame (C).

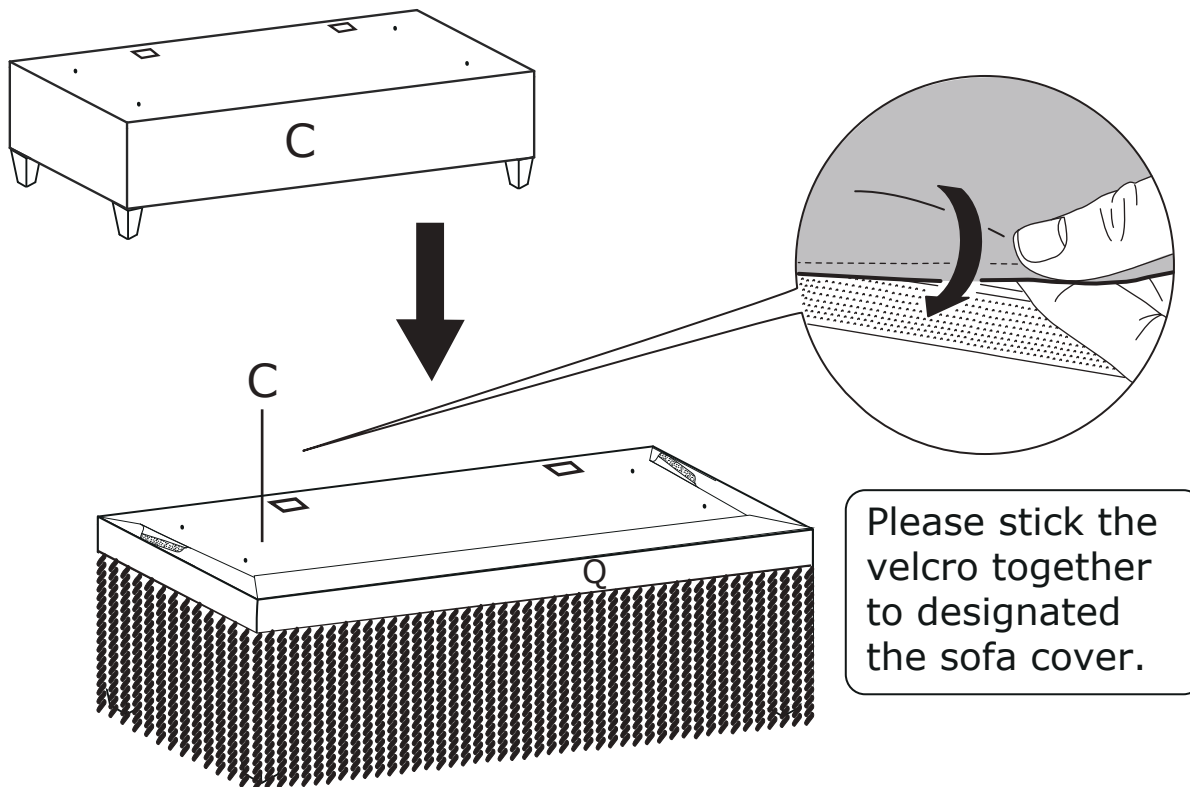

STEP 11 Insert the Backrest (H) into the designated holes, using Washers (T) and Bolts (R) to 70% tightness, and then tighten all bolts on the seat.

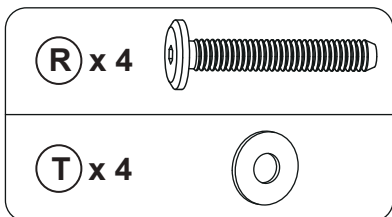
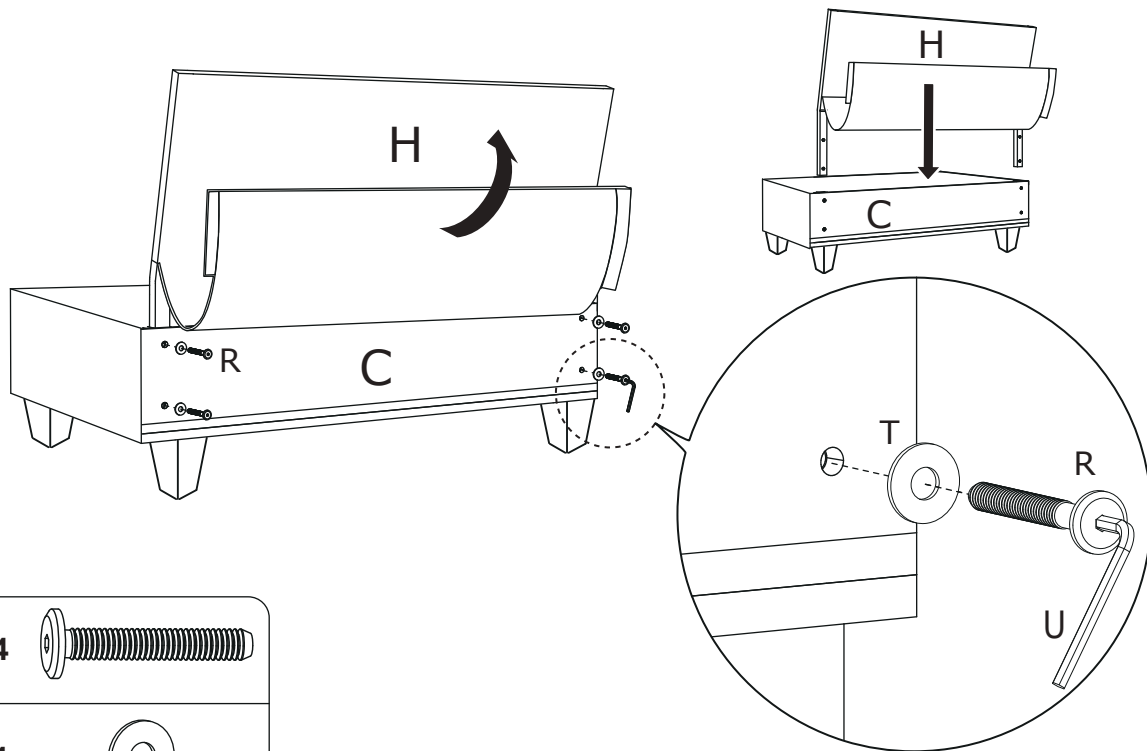

STEP 12 Insert the Connector (K) into the designated holes, then the sofa connected together.

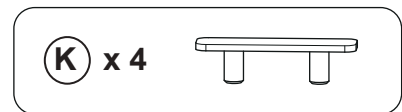
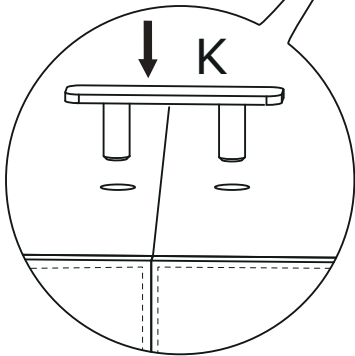
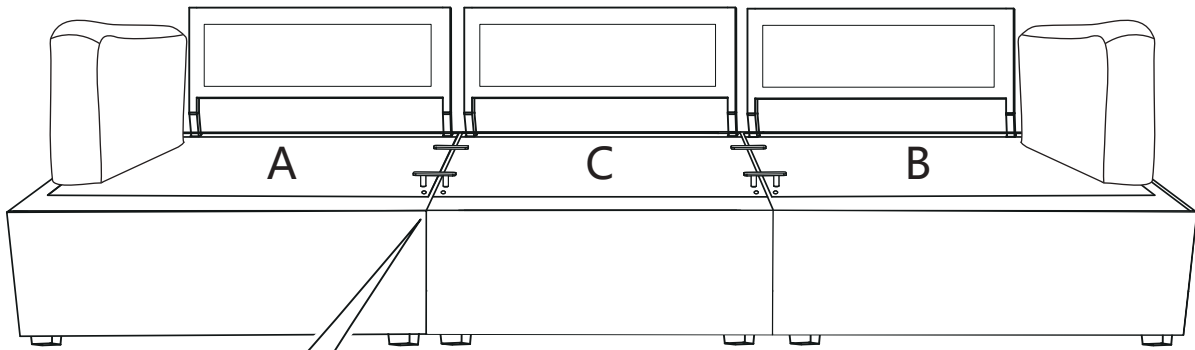
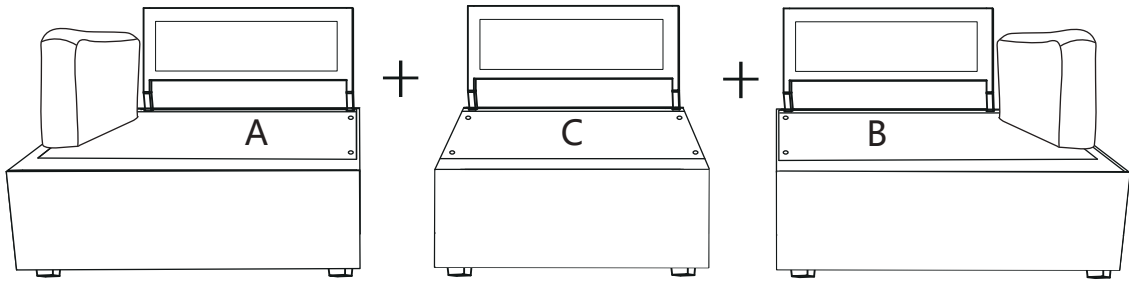

STEP 13 The cushion is packed by vacuum compression. After cutting the package, it rebounds quickly within 4 hours. If the fabric has wrinkles, it will basically disappear after standing for 72 hours. If still has wrinkles after 72 hours, steam with iron is workable.

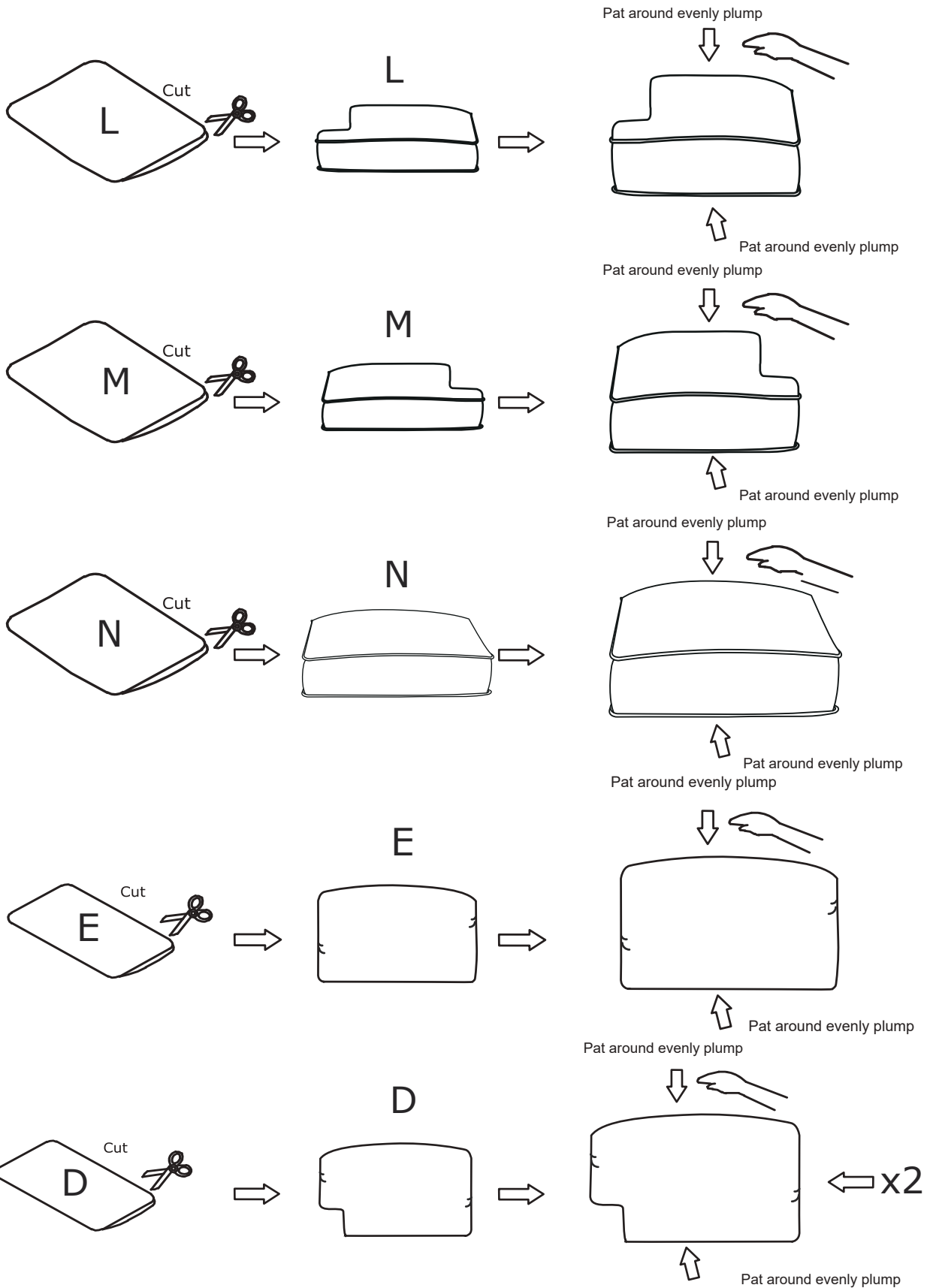

STEP 14 Put Left seat cushion (L), Right seat cushion (M), Back cushion (D), Middle seat cushion (N), Middle back cushion (E), Armrest Pillow(I) and Pillow (J) to the Sofa.

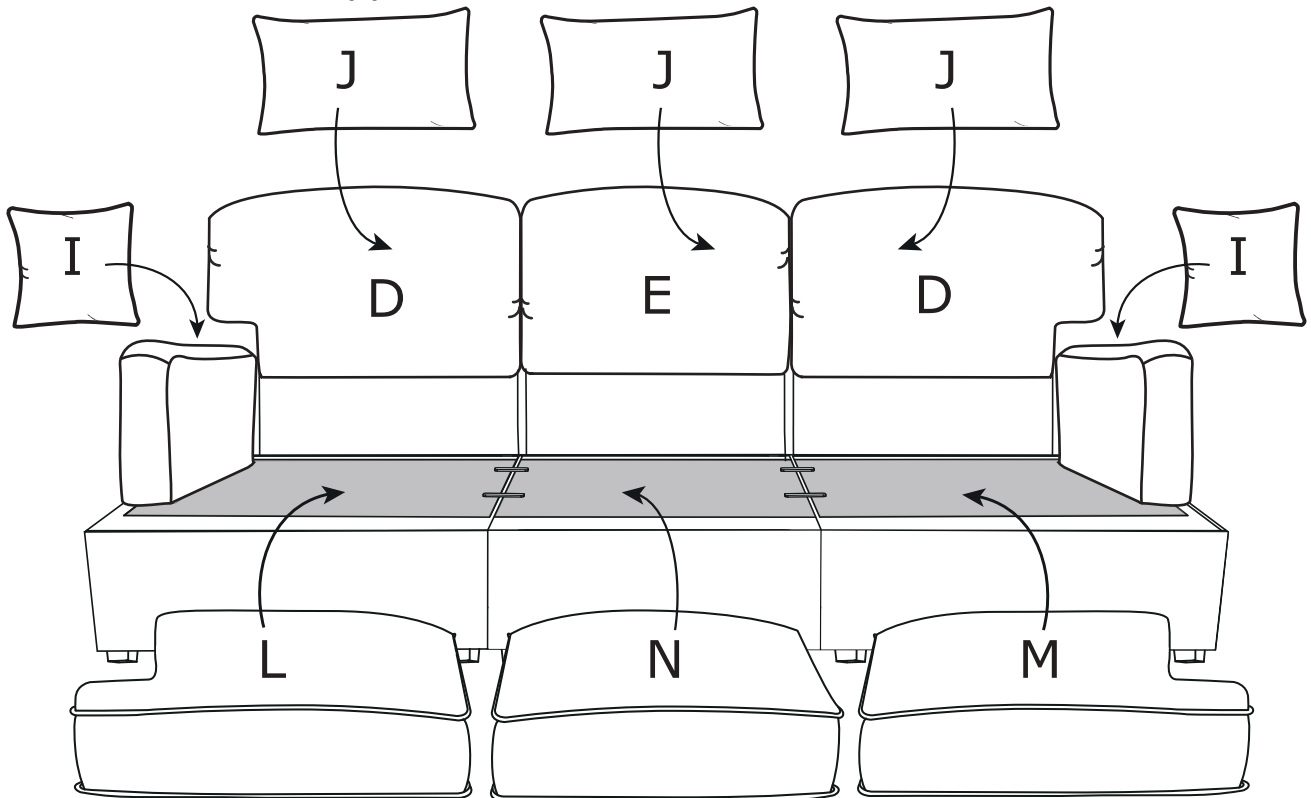

STEP 15 Completed.

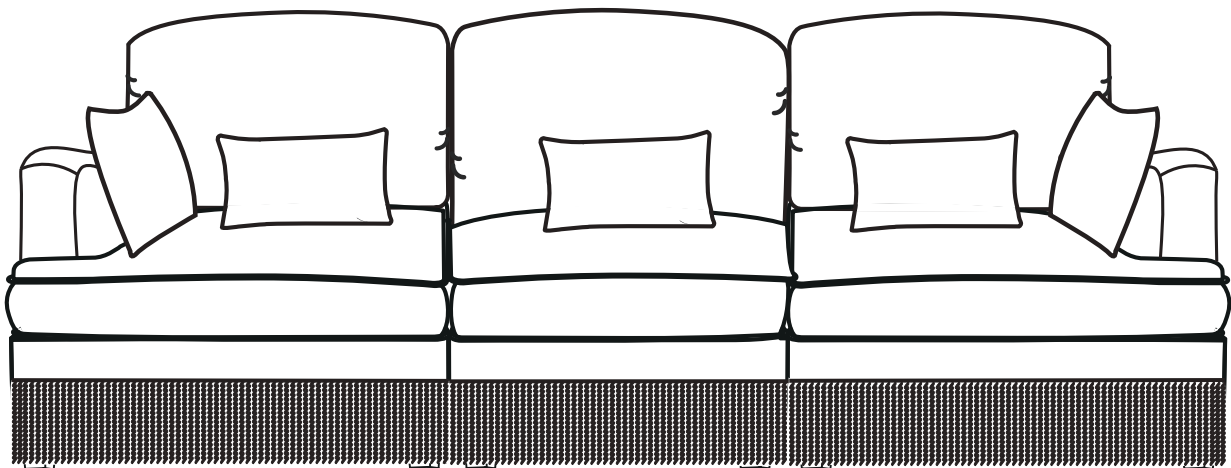

IF YOU BUY 4 SEATER SOFA
please follow below assembly instruction

Parts List (Box 1)

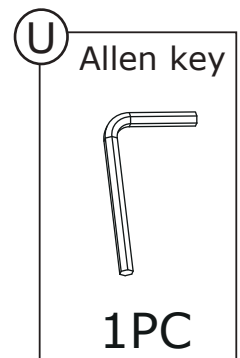
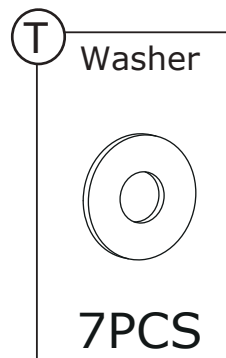
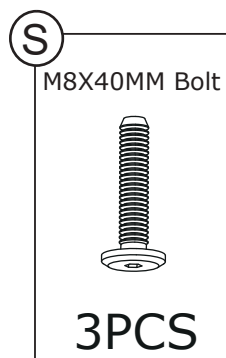
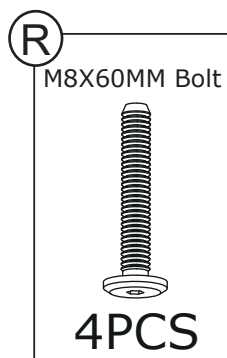
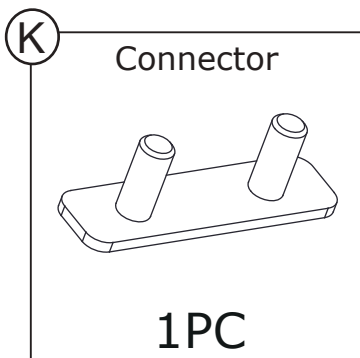
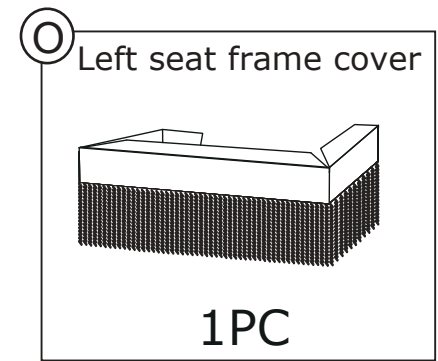
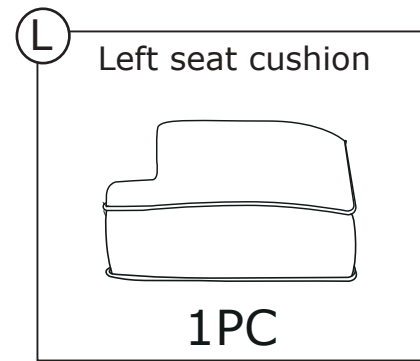
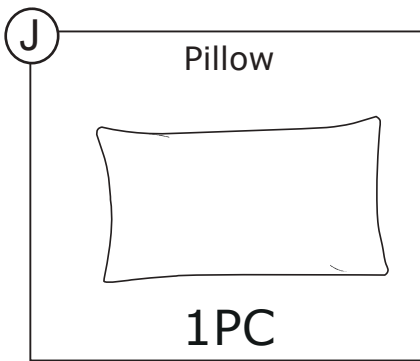
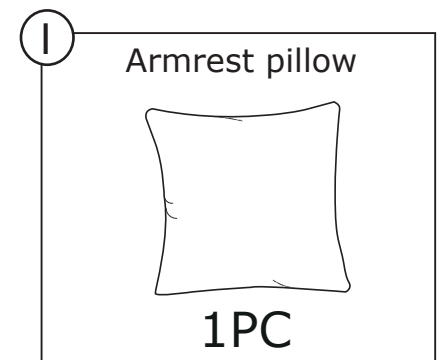
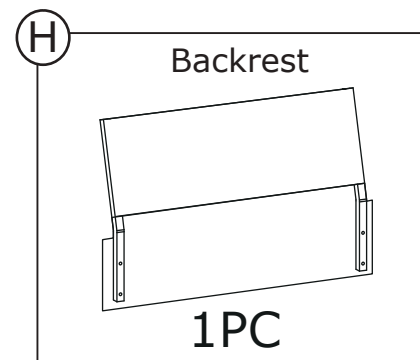
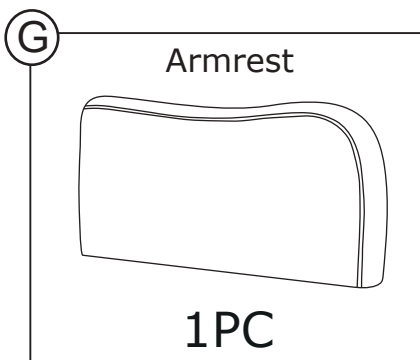
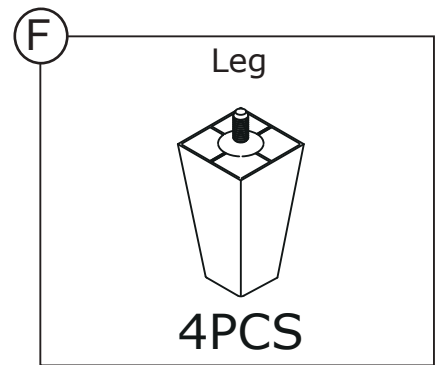
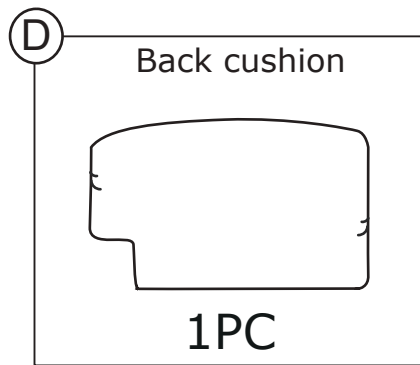
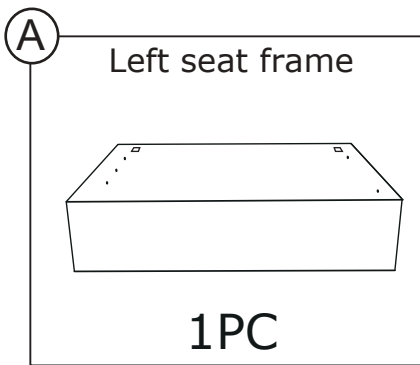

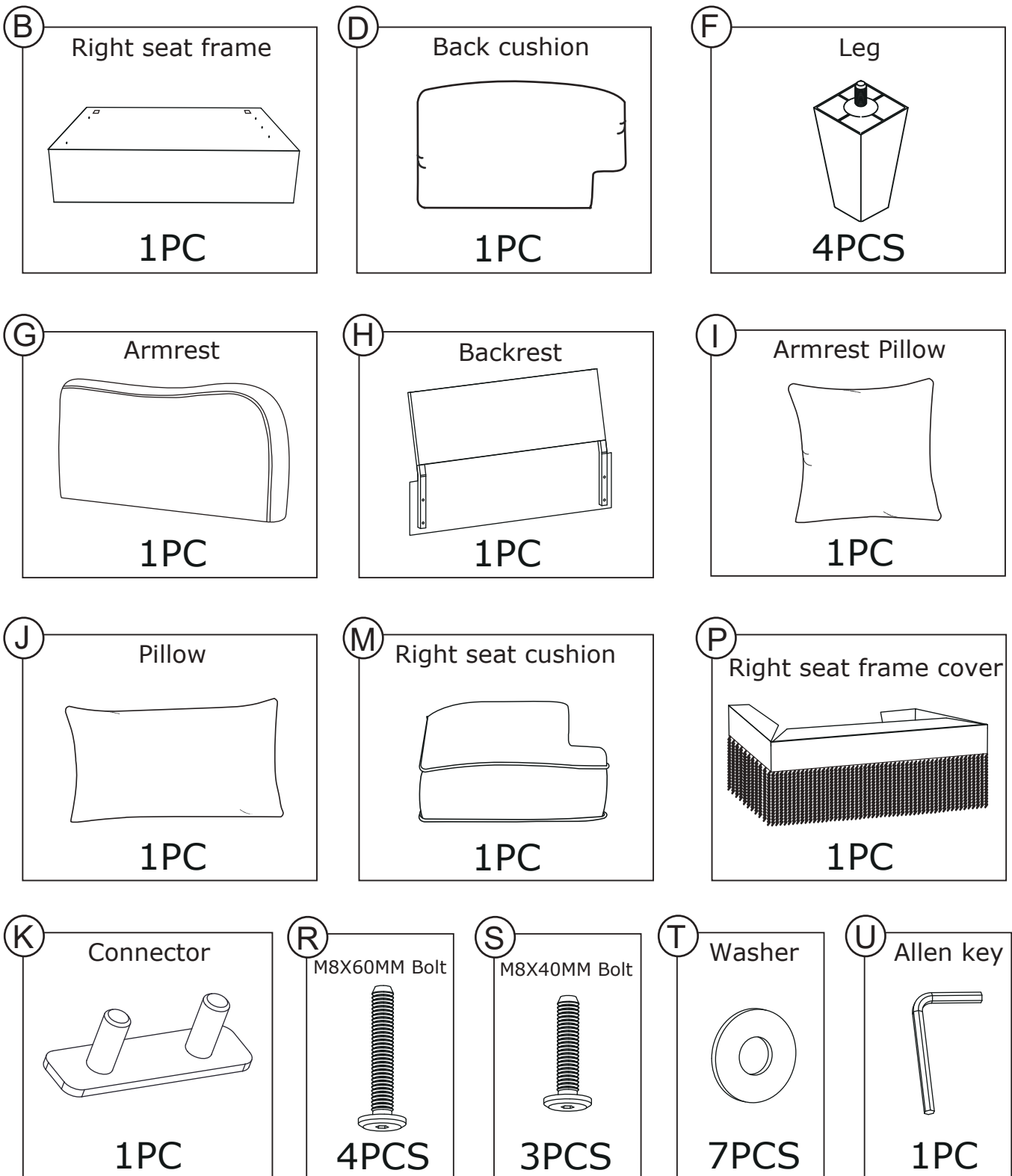

IF YOU BUY 4 SEATER SOFA
please follow below assembly instruction

Parts List (Box 2)

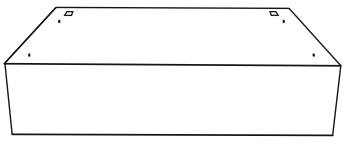
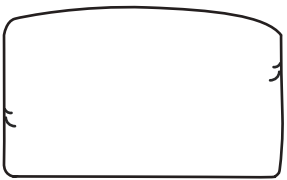
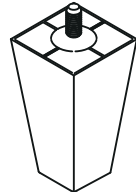
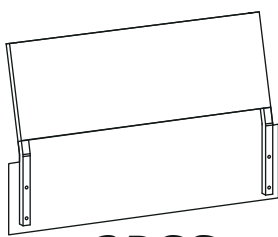
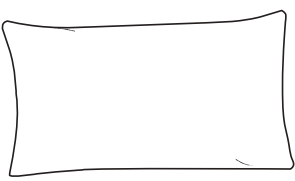
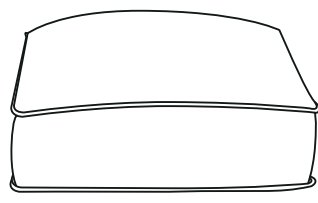
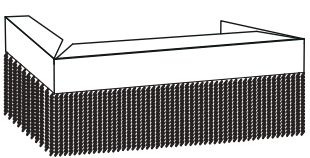
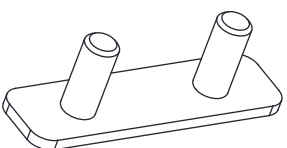

IF YOU BUY 4 SEATER SOFA
please follow below assembly instruction

Parts List (Box 3)

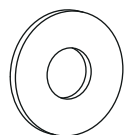
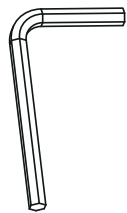
<p>C Middle seat frame</p>  <p>2PCS</p>	<p>E Middle back cushion</p>  <p>2PCS</p>	<p>F Leg</p>  <p>8PCS</p>
<p>H Backrest</p>  <p>2PCS</p>	<p>J Pillow</p>  <p>2PCS</p>	<p>N Middle seat cushion</p>  <p>2PCS</p>
<p>Q Middle seat frame cover</p>  <p>2PCS</p>	<p>K Connector</p>  <p>4PCS</p>	<p>R M8X60MM Bolt</p>  <p>8PCS</p>
<p>T Washer</p>  <p>8PCS</p>	<p>U Allen key</p>  <p>2PCS</p>	

Note: Please retain all boxes until you are certain that your product isn't damaged and that you do not wish to return it. Disposal of boxes may prevent our ability to resolve your request.

ASSEMBLY STEPS

STEP 1 Assemble the Legs (F) to the Left seat frame (A).

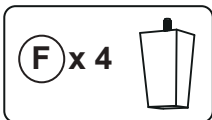
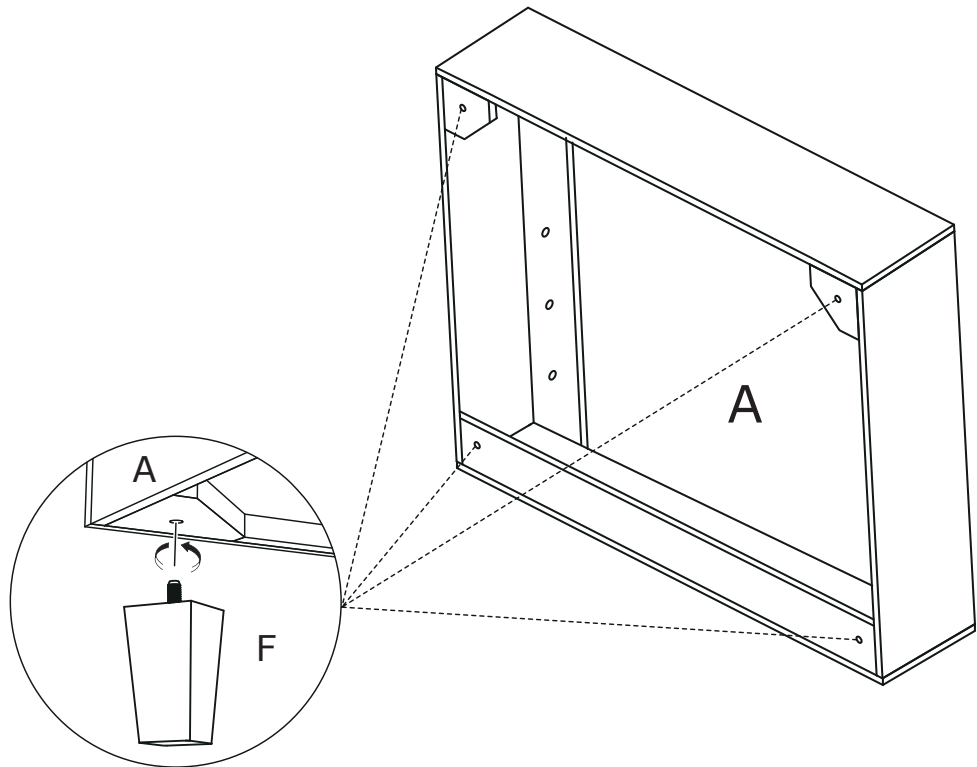

STEP 2 Assemble the Legs (F) to the Right seat frame (B).

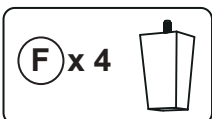
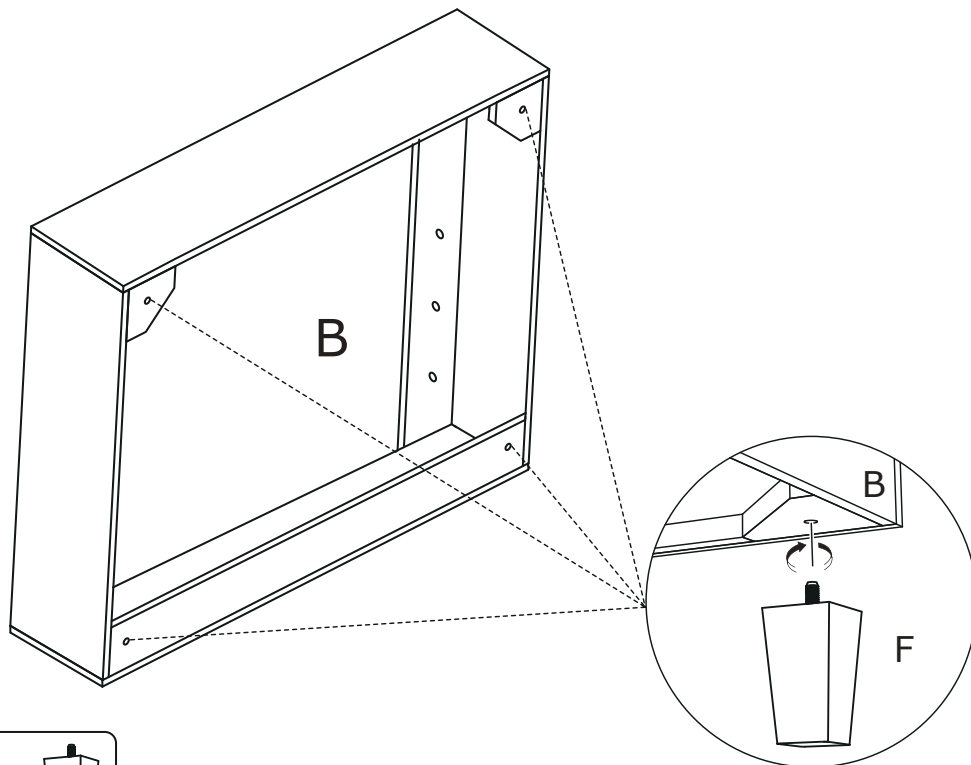

STEP 3 Insert the Left seat frame cover (O) into the Left seat frame (A).

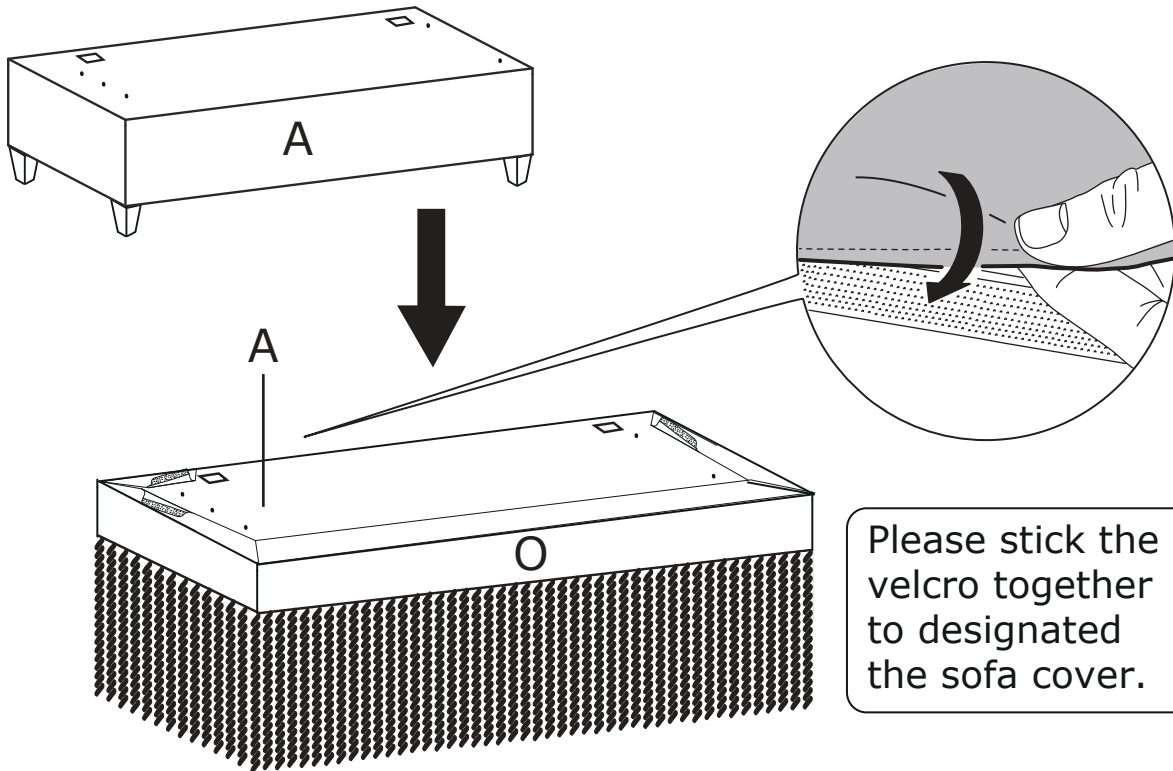

STEP 4 Insert the Right seat frame cover (P) into the Right seat frame (B).

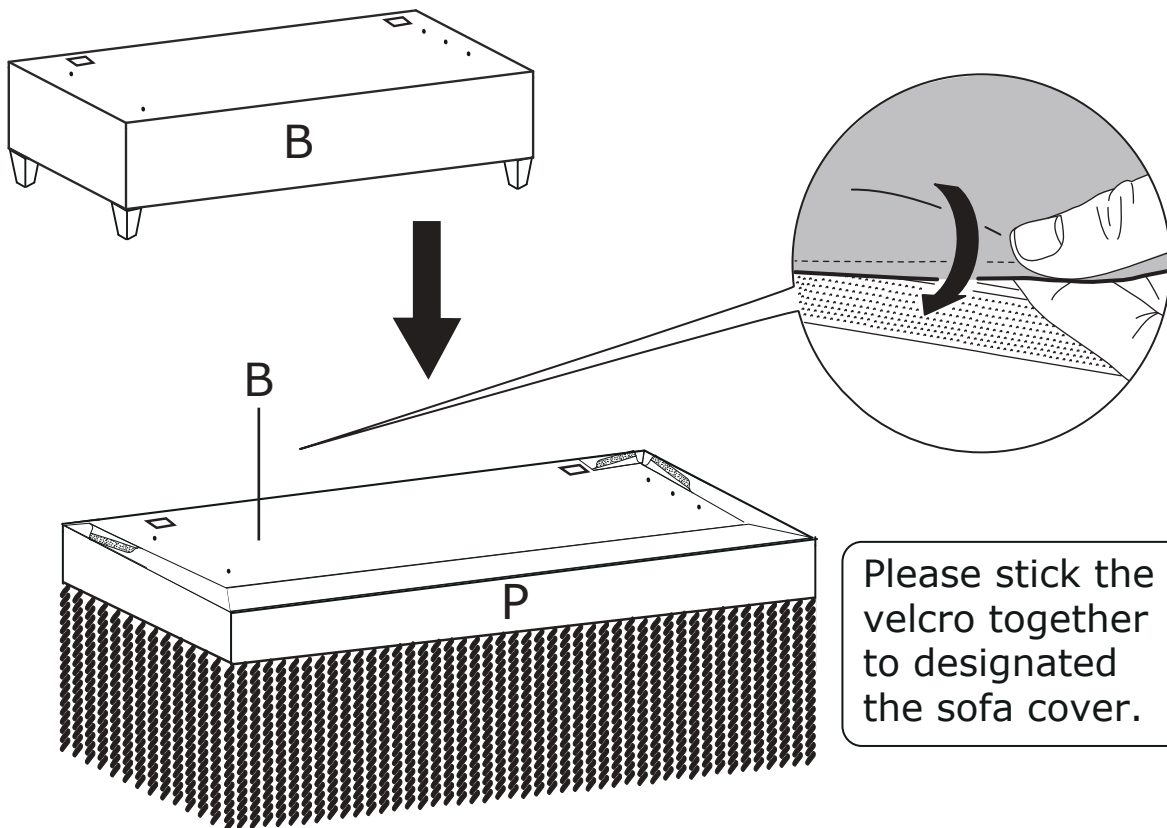

STEP 5 Assemble the armrest (G) to the Left seat frame (A) with Washers (T) and Bolts (S).

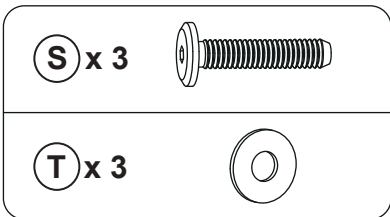
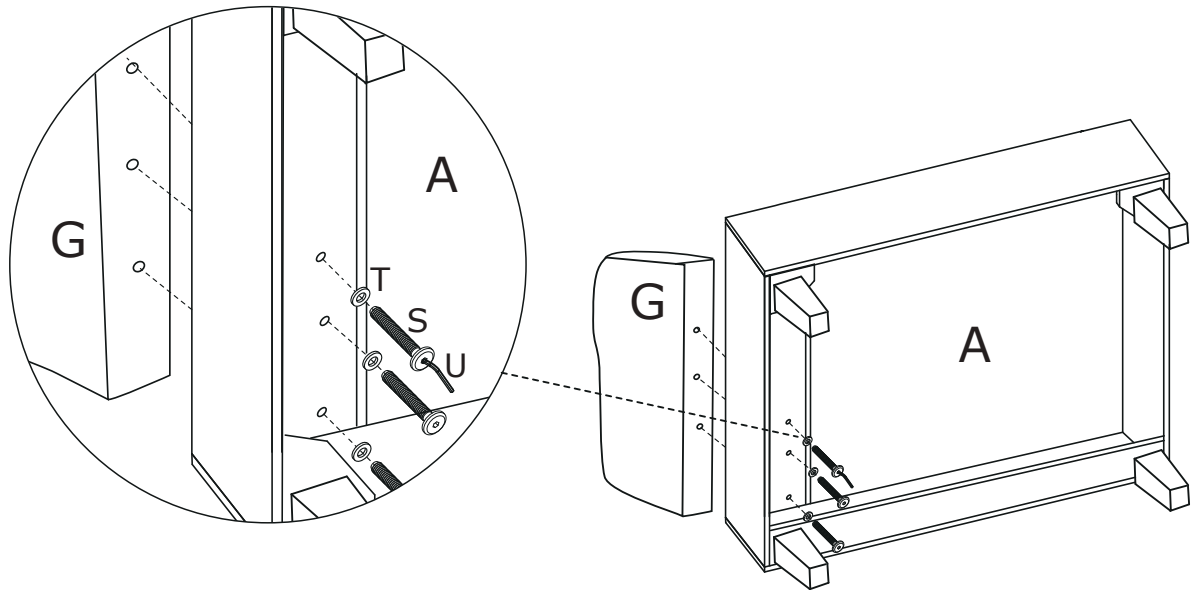

STEP 6 Assemble the armrest (G) to the Right seat frame (B) with Washers (T) and Bolts (S).

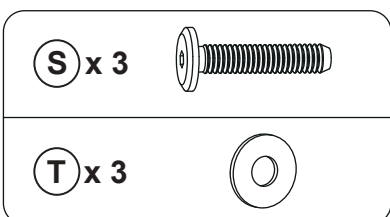
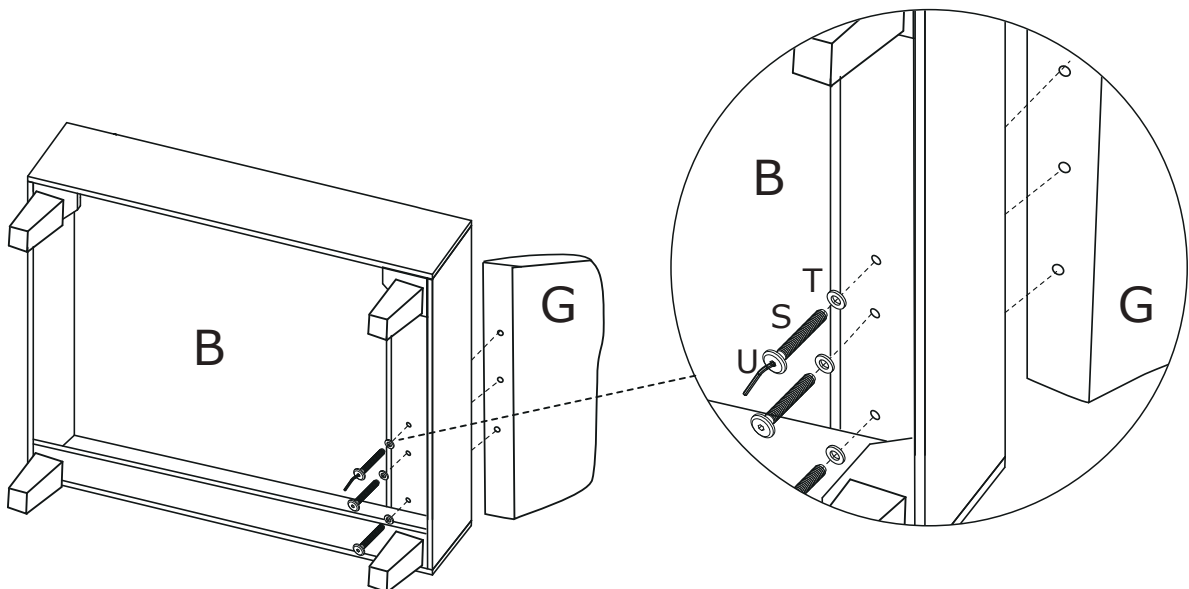

STEP 7 Insert the Backrest (H) into the designated holes, using Washers (T) and Bolts (R) to 70% tightness, and then tighten all bolts on the seat.

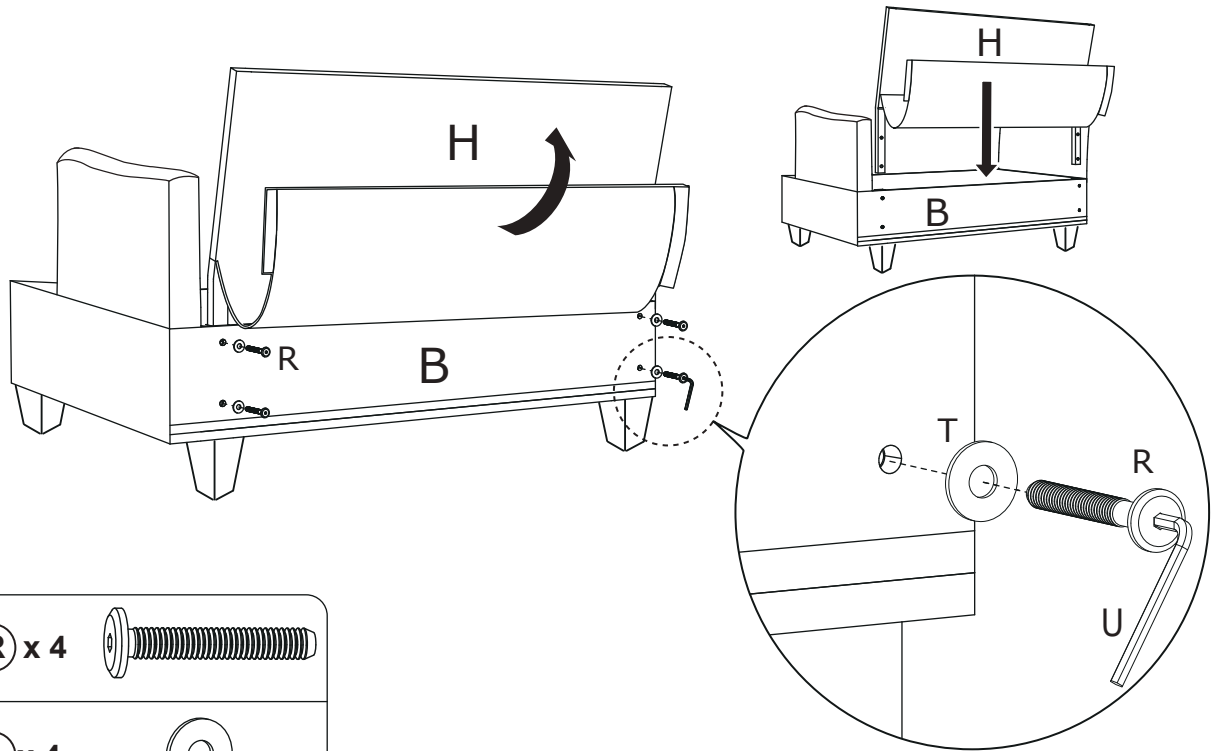

STEP 8 Insert the Backrest (H) into the designated holes, using Washers (T) and Bolts (R) to 70% tightness, and then tighten all bolts on the seat.

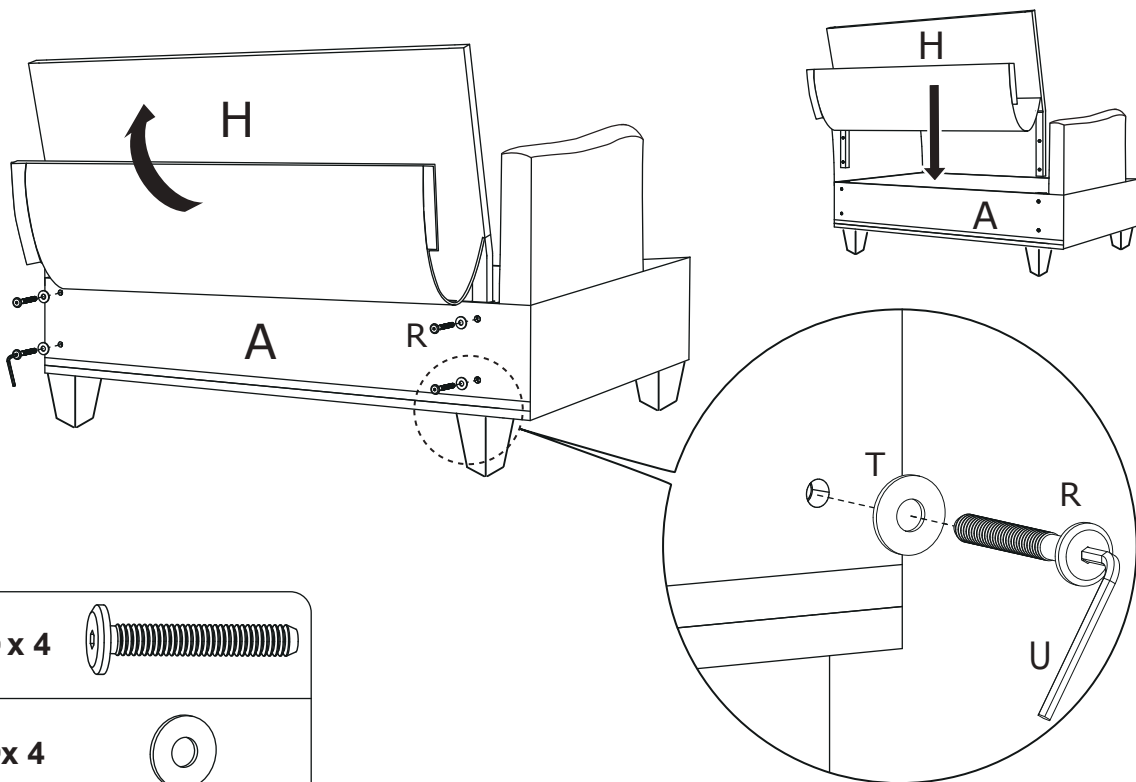

STEP 9 Assemble the Legs (F) to the Middle seat frame (C).

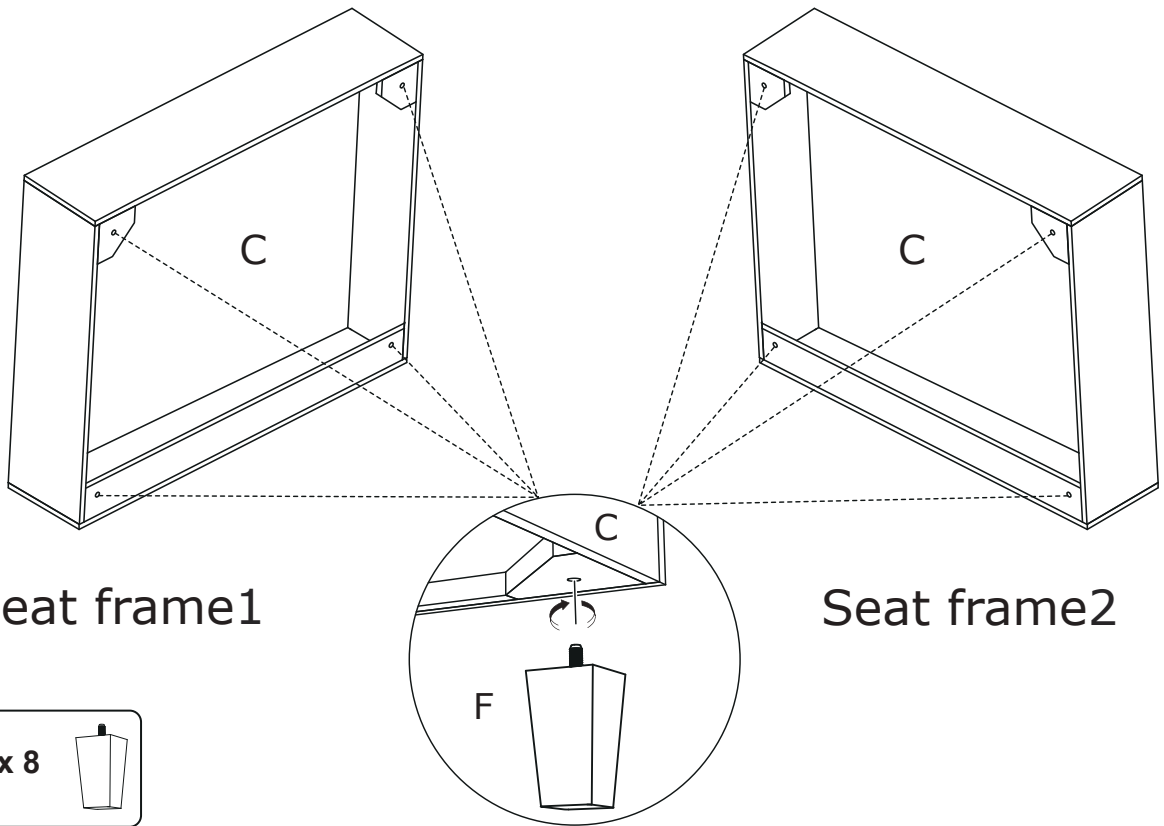

STEP 10 Insert the Middle seat frame cover (Q) into the Middle seat frame (C).

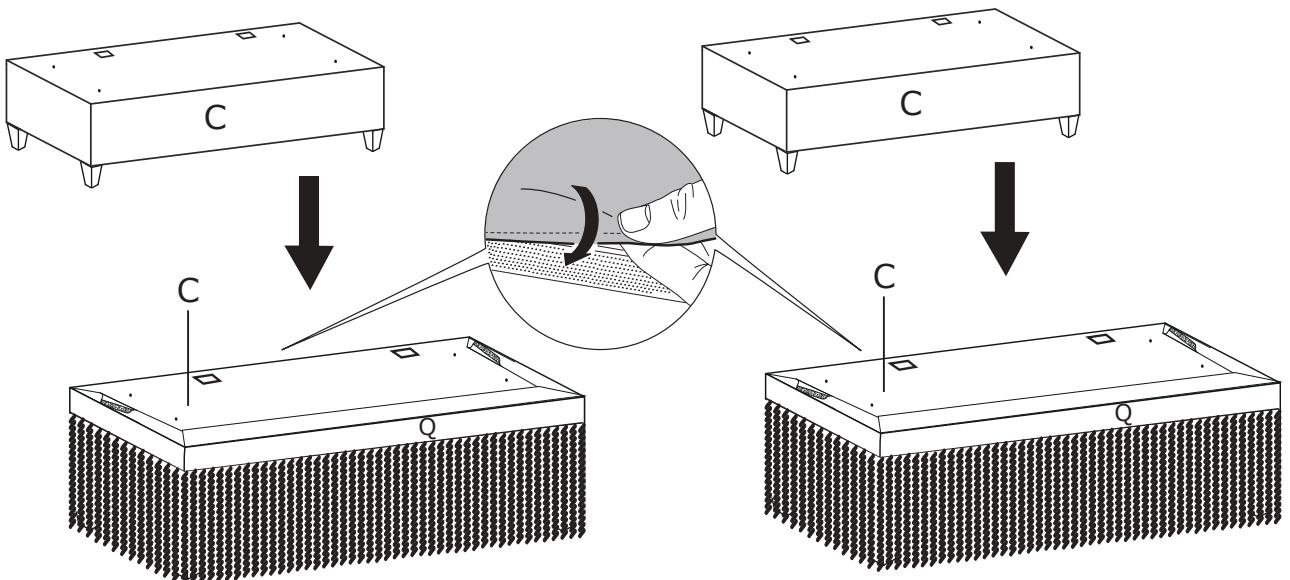

Please stick the velcro together to designated the sofa cover.

STEP 11 Insert the Backrest (H) into the designated holes, using Washers (T) and Bolts (R) to 70% tightness, and then tighten all bolts on the seat.

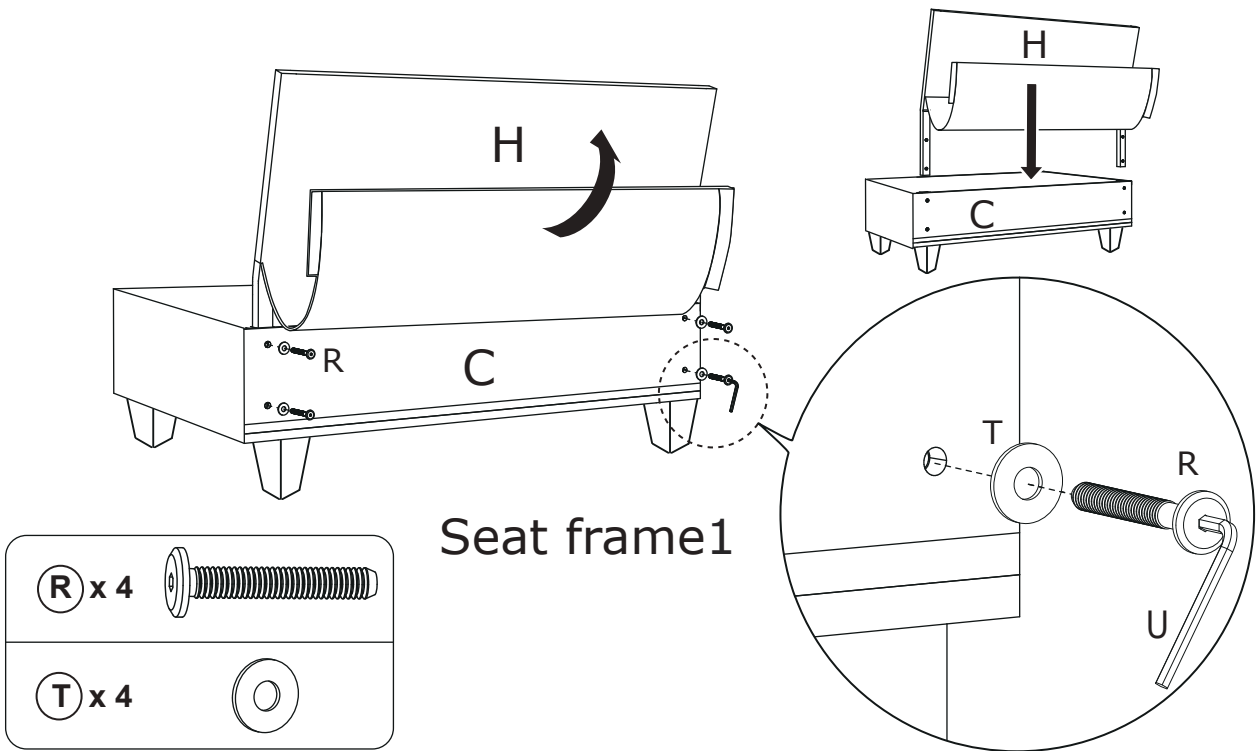

STEP 12 Insert the Backrest (H) into the designated holes, using Washers (T) and Bolts (R) to 70% tightness, and then tighten all bolts on the seat.

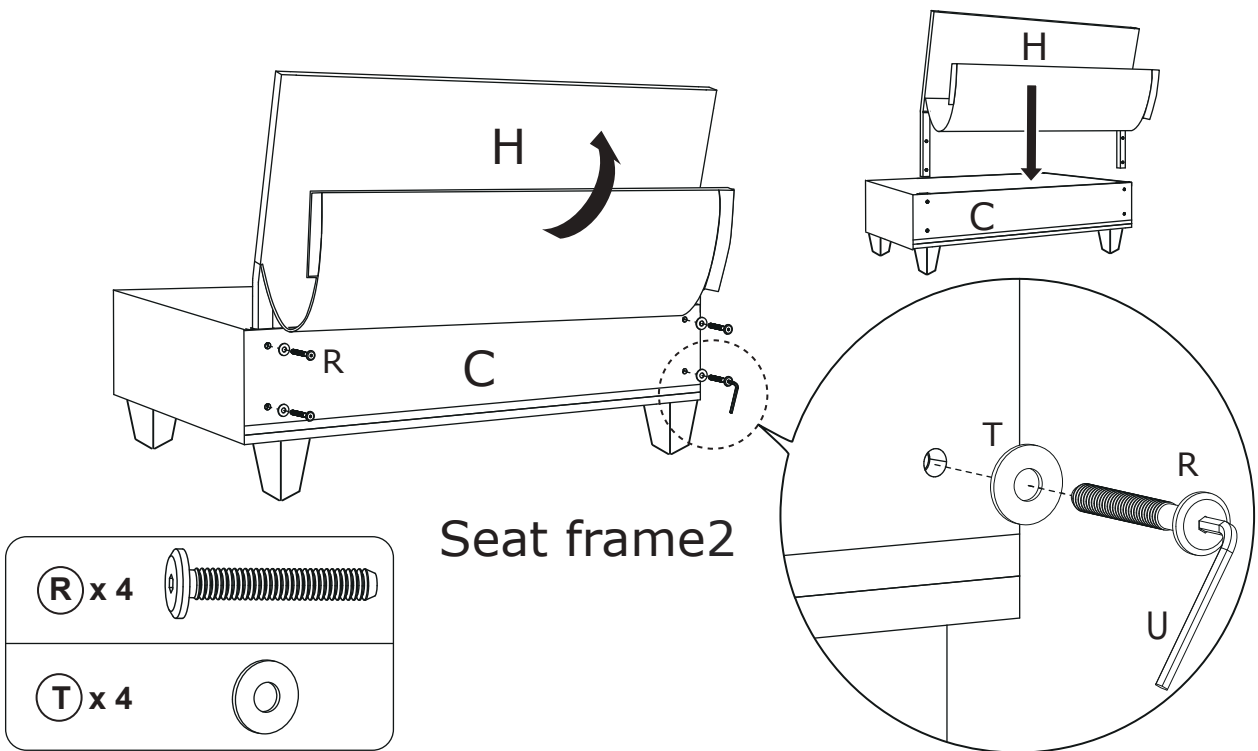

STEP 13 Insert the Connector (K) into the designated holes, then the sofa connected together.

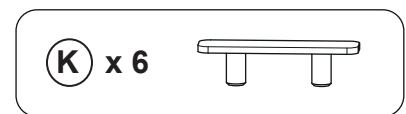
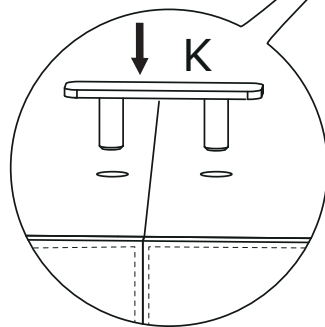
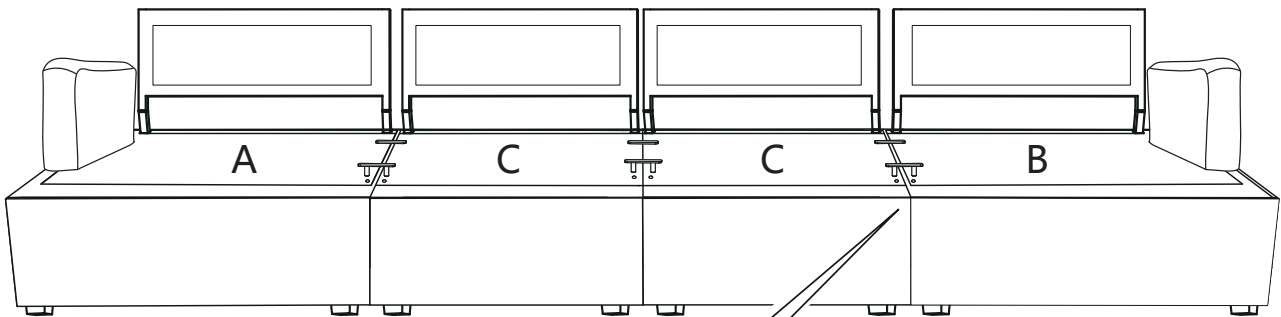
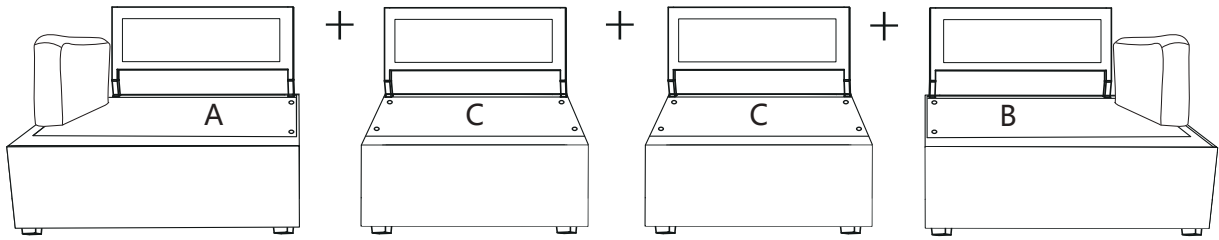

STEP 14 The cushion is packed by vacuum compression. After cutting the package, it rebounds quickly within 4 hours. If the fabric has wrinkles, it will basically disappear after standing for 72 hours. If still has wrinkles after 72 hours, steam with iron is workable.

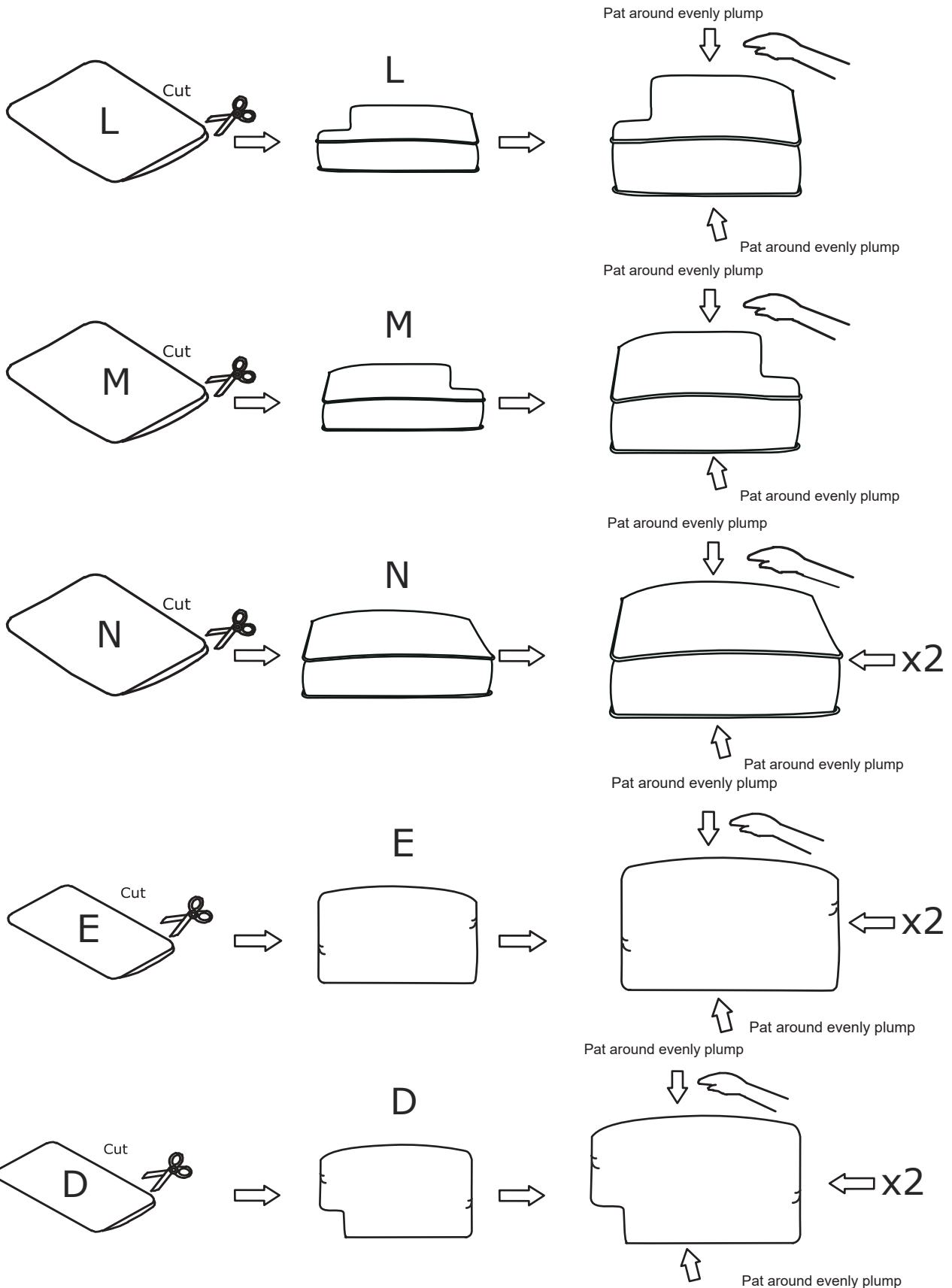

STEP 15 Put Left seat cushion (L), Right seat cushion (M), Back cushion (D), Middle seat cushion (N), Middle back cushion (E), Armrest Pillow(I) and Pillow (J) to the Sofa.

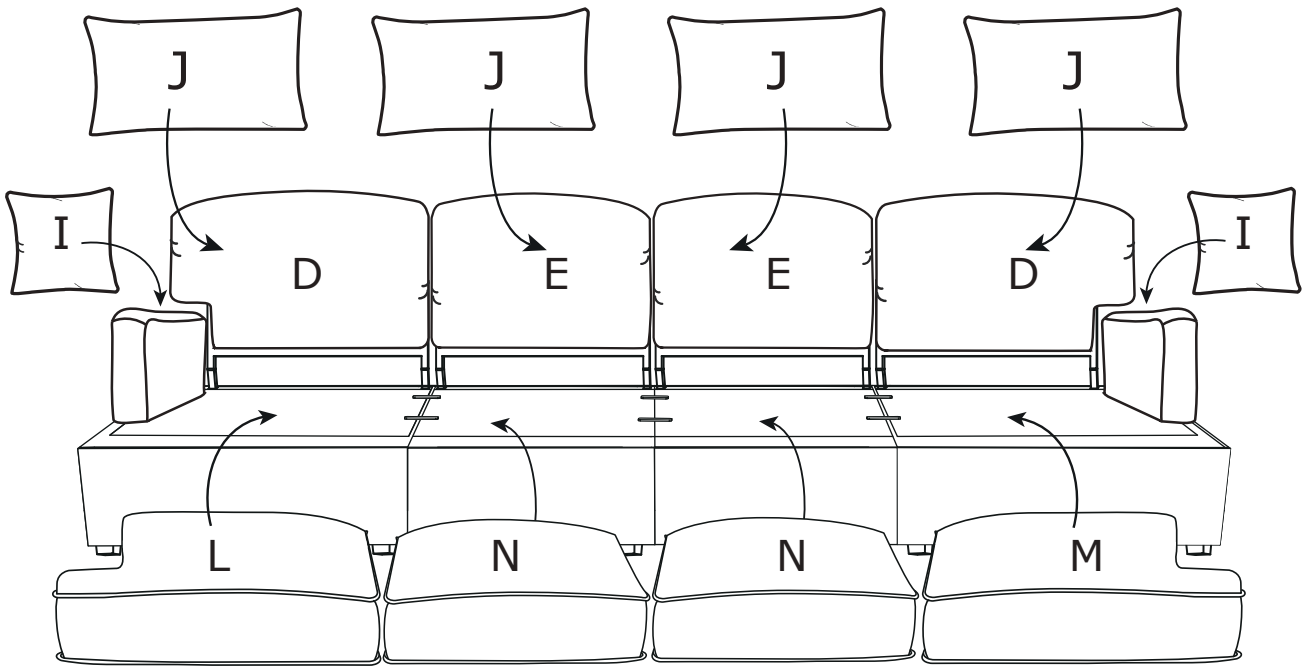

STEP 16 Completed.

