

ASSEMBLY INSTRUCTIONS

TOOLS REQUIRED



Allen Wrench

(Included)

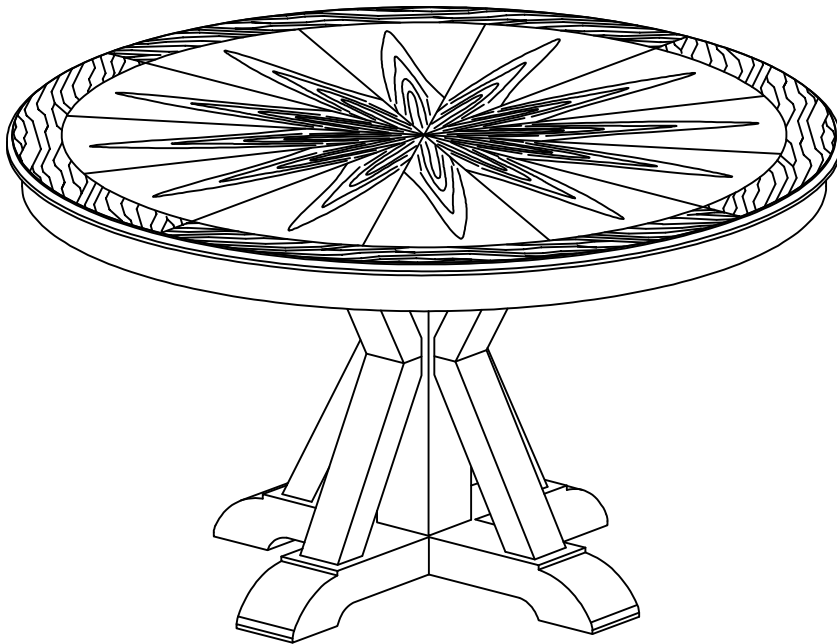

2 - People
Recommended

ASSEMBLY RATING

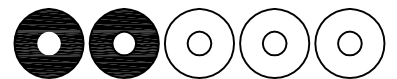

EASY —————> DIFFICULT

The Assembly Rating is a 5-point system showing the level of effort needed to assemble a specific product.

PRE ASSEMBLY INTRODUCTION

We understand building ready-to-assemble furniture can be a challenging experience for some. To help avoid confusion, we have provided some helpful tips that may speed up the process.



Teamwork

ALWAYS have at least two people to help with transporting and assembling the product to avoid potential injury and/or damage.



Suitable Location

Assembling near the area of the intended location is highly recommended.



Sufficient Space

Make sure you have enough space to move around during the assembly.

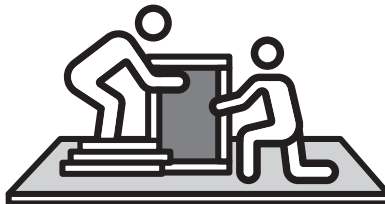

Avoid Scratches

Use cardboard, blankets or a carpeted area while assembling furniture to prevent scratches.



Flat Surface

Make sure the furniture rests on a flat and level surface with each leg evenly touching the floor.

ASSEMBLY AND CARE ADVICE



FAILURE TO FOLLOW THE GUIDELINES BELOW MAY RESULT IN INJURY AND/OR PROPERTY DAMAGE.



Position each part correctly and insert screws or bolts into their respective holes.



Turn clockwise to tighten and only tighten when step is completed or when instructed to do so.



Use the appropriate hand tools or power tools for assembly. Select steps, such as tightening screws and/or bolts, may require hand tools to avoid causing damage during assembly.



Save the instructions and store any supplied tools for later maintenance.



After two weeks, check and tighten any loose hardware and repeat again every six months thereafter.

IT IS THE USER'S RESPONSIBILITY TO MAINTAIN THE FURNITURE. THE HARDWARE MAY LOOSEN OVER TIME AND MAY CAUSE THE FURNITURE TO BE WOBBLY AND UNABLE TO SUPPORT ITS INTENDED WEIGHT CAPACITY. THIS MAY LEAD TO COLLAPSE AND MAY CAUSE SERIOUS INJURY.

ROUND DINING TABLE



- Please keep instructions for future reference.
- Check the quantity and irregularity of parts and hardware before you start.

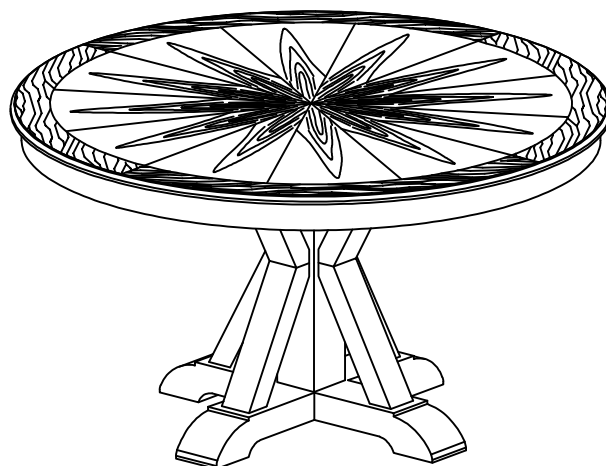

PARTS

#1 1pc



Top Table

#2 1pc

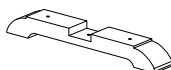

Base Bottom

#3 1pc

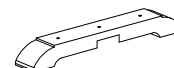

Base Top

#4 1pc

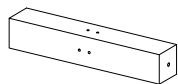

Pedestal Column

#5 4pcs



Leg

#6 1pc

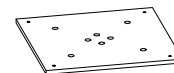

Mounting Plate

HARDWARE

#A 5pcs



Bolt Ø5/16" x3"

#B 5pcs



Bolt Ø5/16" x2"

#C 4pcs



Bolt Ø5/16" x 1-1/2"

#D 14pcs



Lock Washer
Ø5/16"x13mm

#E 14pcs



Flat Washer
Ø5/16"x19mm

#F 1pc



Allen Wrench M4

Exploded View

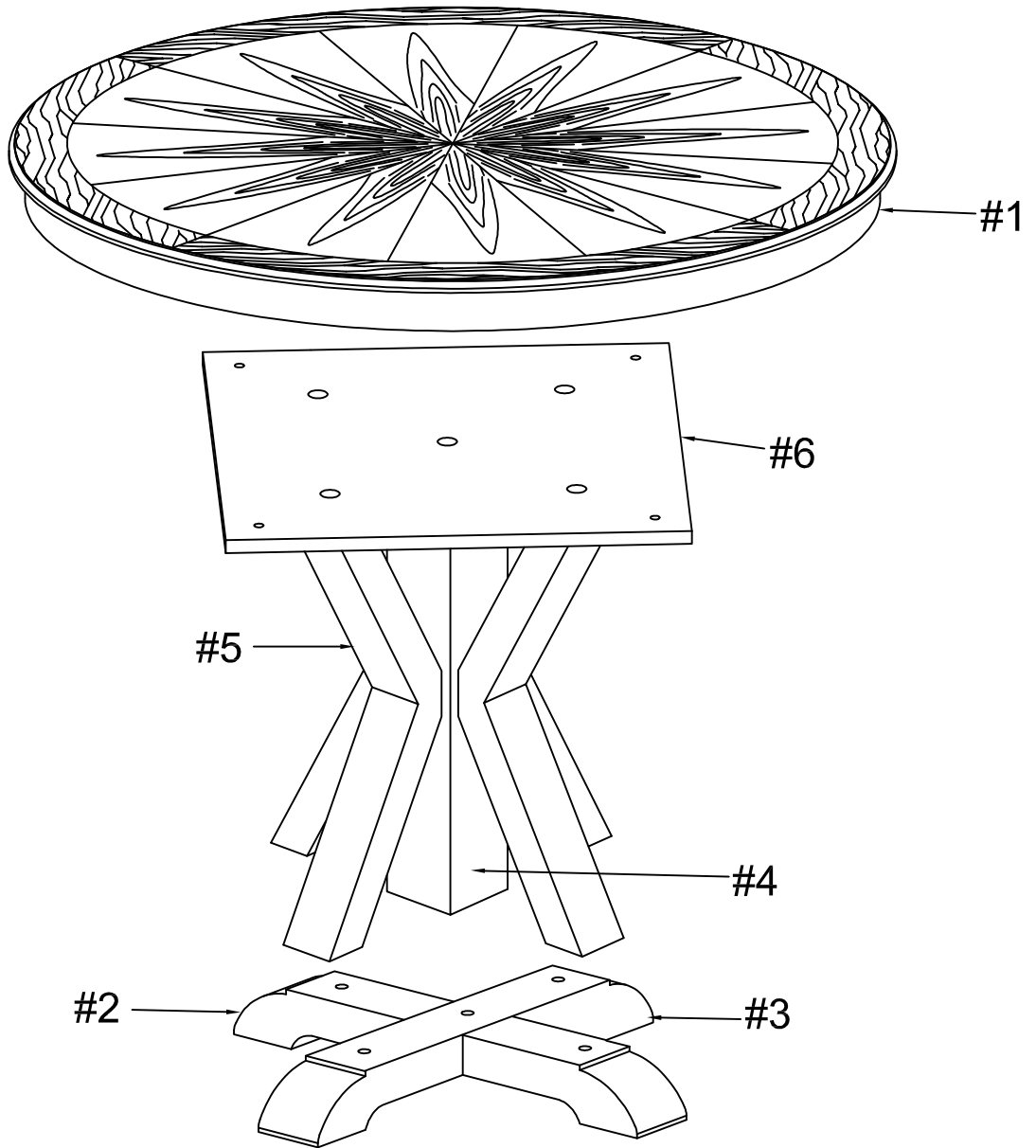

ASSEMBLY INSTRUCTIONS

1

- Part #4 x1pc
- Part #5 x4pc
- Part #6 x1pc
- Hardware #B x5pcs
- Hardware #D x5pcs
- Hardware #E x5pcs

Prepare 5 bolts assembly by inserting lock washer (#D), then flat washer (#E) onto bolts (#B). Align and attach legs (#5) to the holes of the pedestal (#4). Align mounting plate (#6) to the top holes of the legs (#5) and pedestal (#4). Secure by using bolts (#B).

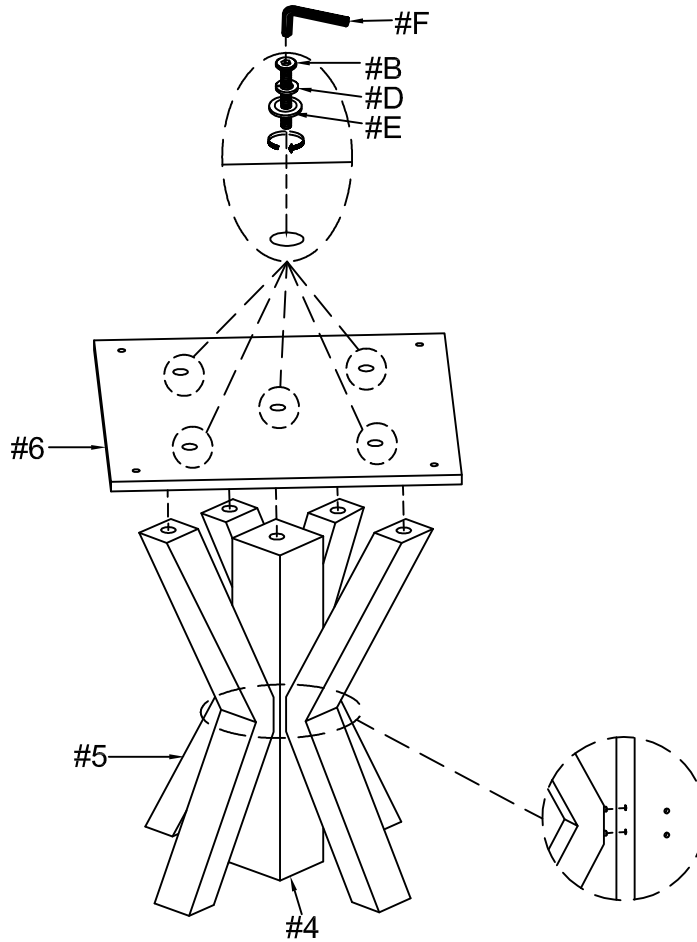

2

- Part #2 x1pc
- Part #3 x1pc
- Hardware #A x5pcs
- Hardware #D x5pcs
- Hardware #E x5pcs

Prepare 5 bolts assembly by inserting lock washer (#D), then flat washer (#E) onto bolts (#A). Align base top (#3) and then base bottom (#2) to the holes of the legs (#5) and pedestal (#4). Secure by using bolts (#A).

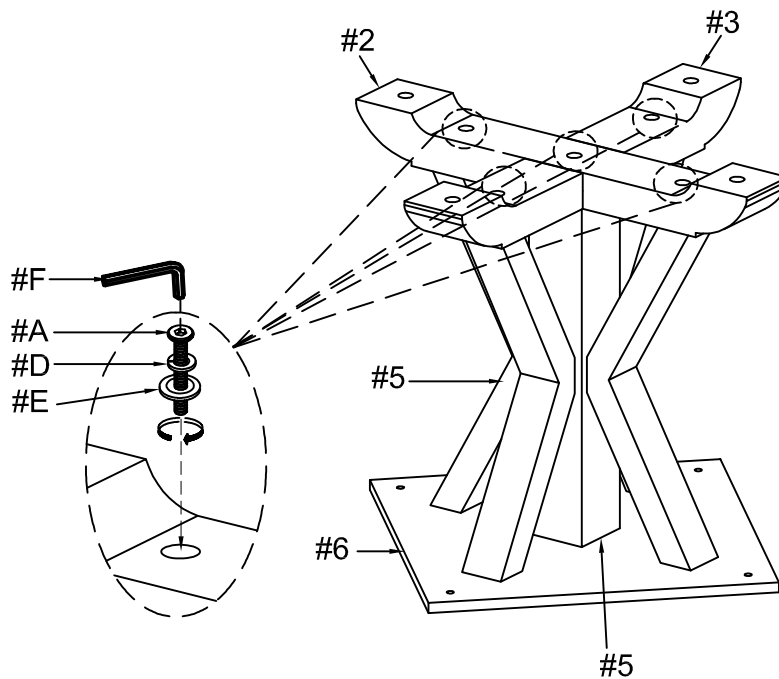

ASSEMBLY INSTRUCTIONS

3

Prepare 4 bolts assembly by inserting lock washer (#D), then flat washer (#E) onto bolts (#C). Align mounting plate (#6) to the holes of the table top (#1). Secure by using bolts (#C).

Part #1 x1pc

Hardware #C x4pcs

Hardware #D x4pcs

Hardware #E x4pcs

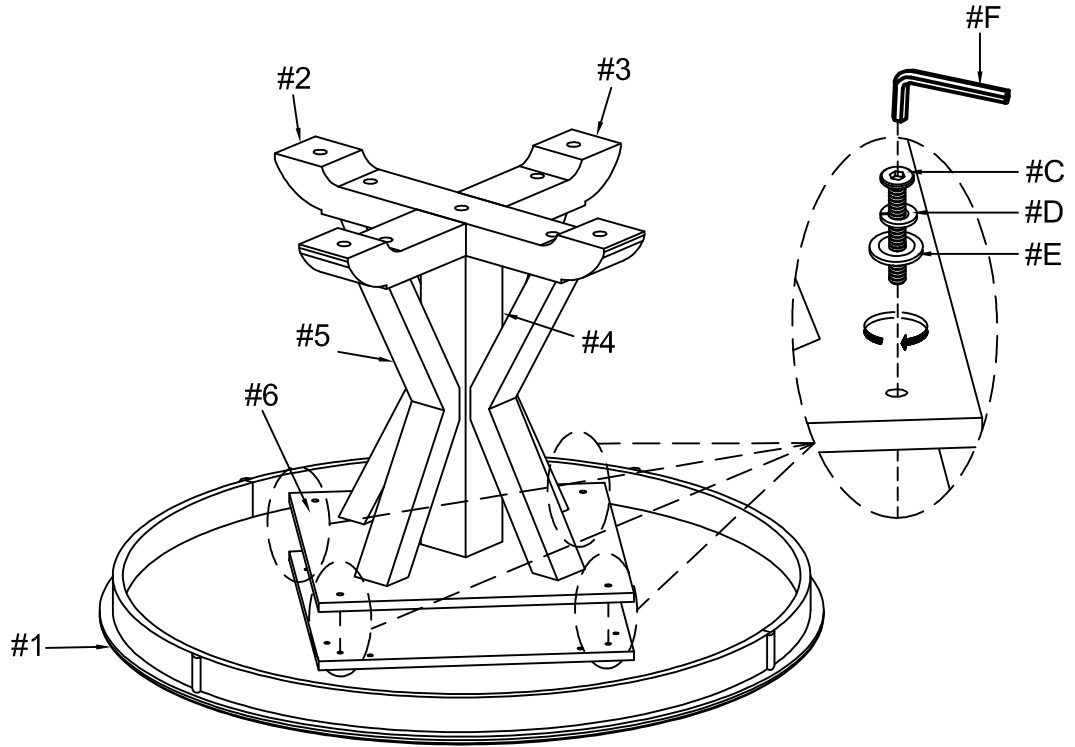

4

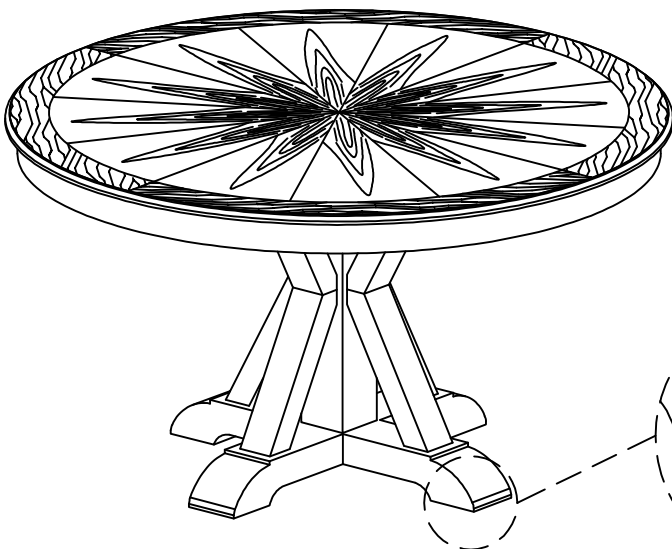

Adjust leveler at the bottom of the base according to ground level.

ADJUSTABLE
LEVELER

ASSEMBLY COMPLETED



Please ensure the furniture rests on an even and flat surface. If the product wobbles or feels loose, double-check all bolts and/or screws are properly tightened and secured.



Keep this handy!

Please retain this instruction manual and any order-related information for future reference.



Lift, don't drag!

To avoid damage to product please always LIFT the product when transporting or adjusting the placement.