













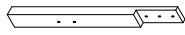

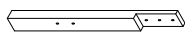
ASSEMBLY INSTRUCTION

Description : KING BED

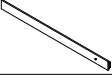
Thank you for purchasing this quality product. Be sure to check all packing material carefully for small parts that may have come loose inside the carton during shipment.

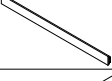
PART LIST :

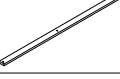
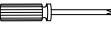
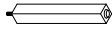
HARDWARE LIST :

No.	Description	Diagram	Quantity	No.	Description	Diagram	Size	Quantity
A	HEADBOARD PANEL		1	H	JCBB SCREW		M8 x 40mm	6
B	LEFT HEADBOARD LEG		1	I	JCBB SCREW		M8 x 25mm	8
C	RIGHT HEADBOARD LEG		1	J	SPRING WASHER		M8 x 15mm	14
D	FOOTBOARD		1	K	FLAT WASHER		M8 x 22mm	14
E1	LEFT SIDE RAIL (WITH TOUCH SENSOR)		1	L	CB SCREW		M4 x 32mm	6
E2	RIGHT SIDE RAIL		1	M	ALLEN KEY		M5	1
F	WOODEN SLAT		3	N	SCREW DRIVER (*)			1
G	WOODEN SUPPORT		6	O	ADAPTOR			1

(*) The manufacturer does not provide item N.

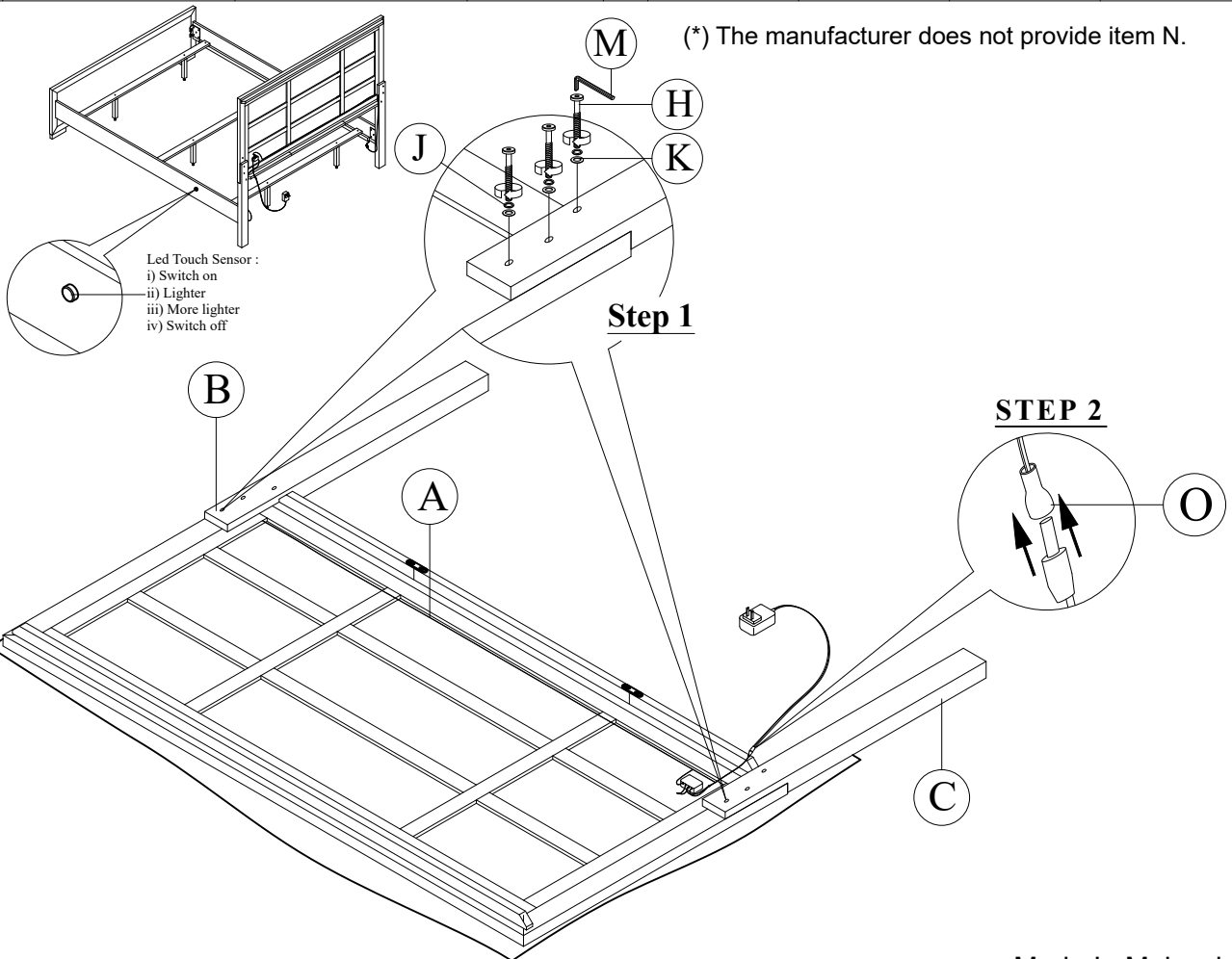

Made In Malaysia

ASSEMBLY INSTRUCTION

Description : KING BED

Thank you for purchasing this quality product. Be sure to check all packing material carefully for small parts that may have come loose inside the carton during shipment.

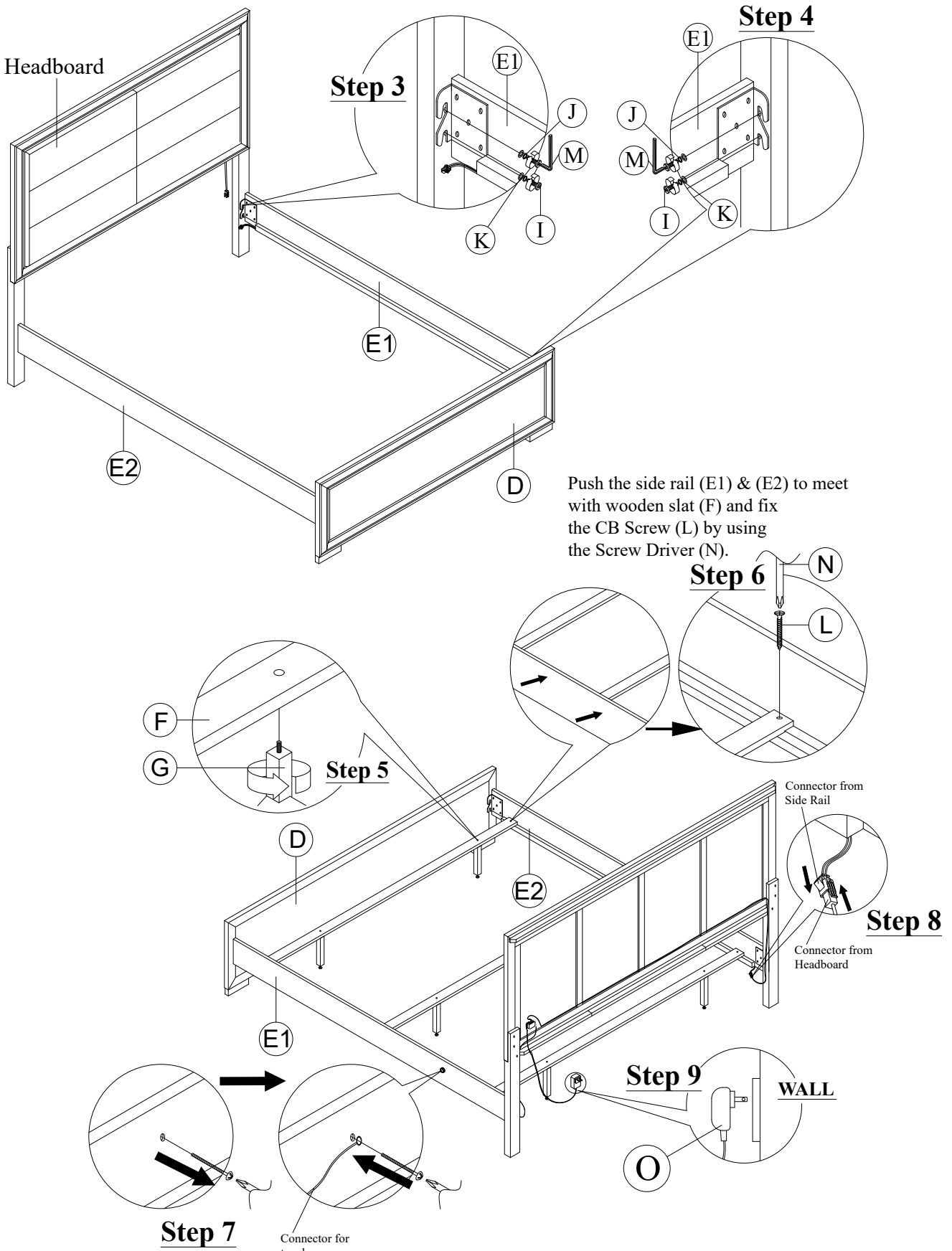

Made In Malaysia