

# User's Manual

## Bed Frame



### Note:

1. Should be assembled on flat ground to keep balance.
2. Before completing the installation, do not tighten the screws.
3. Please contact **after-service** directly for any breakage problem of the product, we will provide you with satisfactory service.

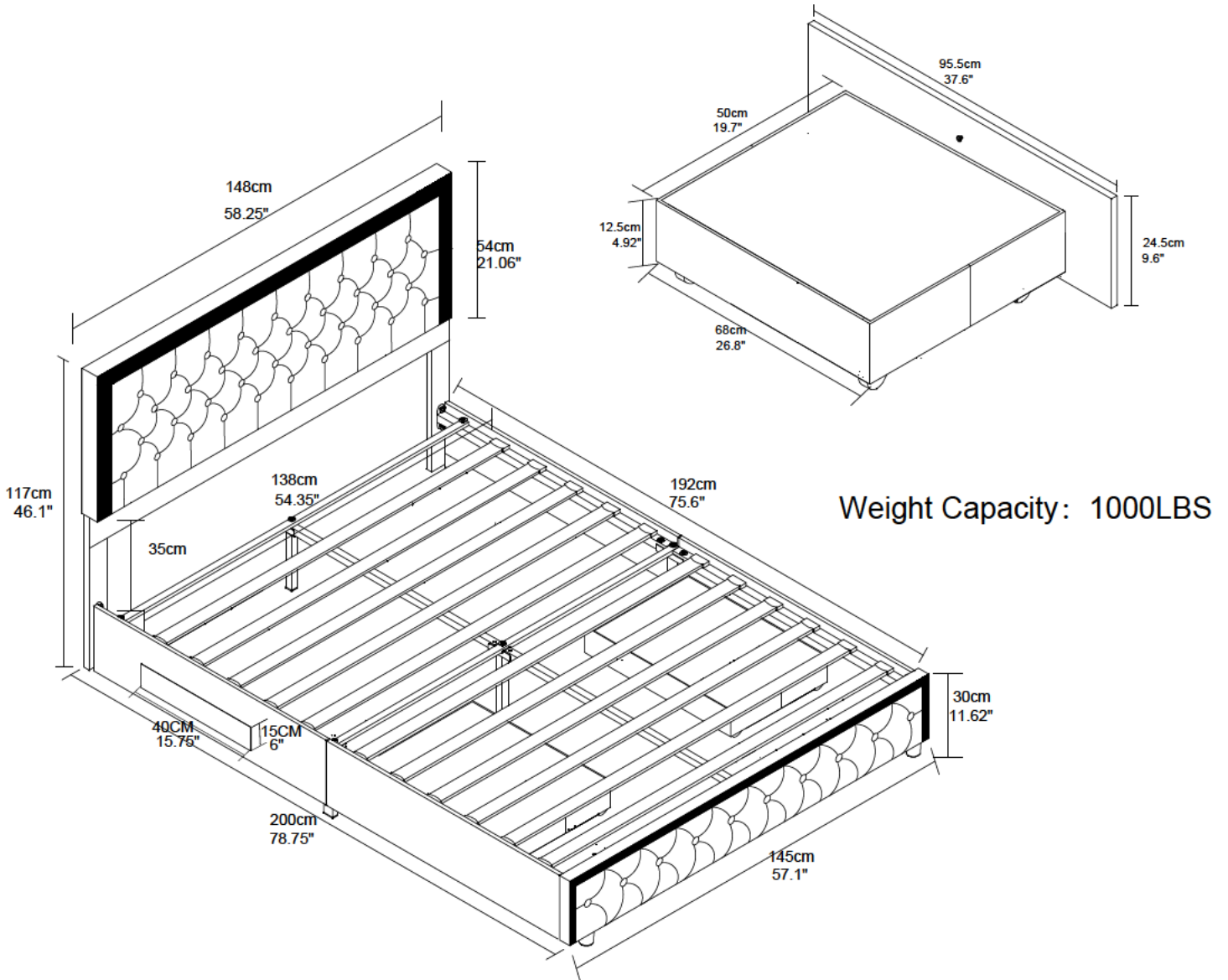

Before starting the assembly, you must read the whole manual and follow the instructions



It needs at least two people to install.

## EN | ES

Contact us first if you have any problems, we would do better than Platform's official service. Replacement for missing or damaged parts will be shipped ASAP!

## EN | ES





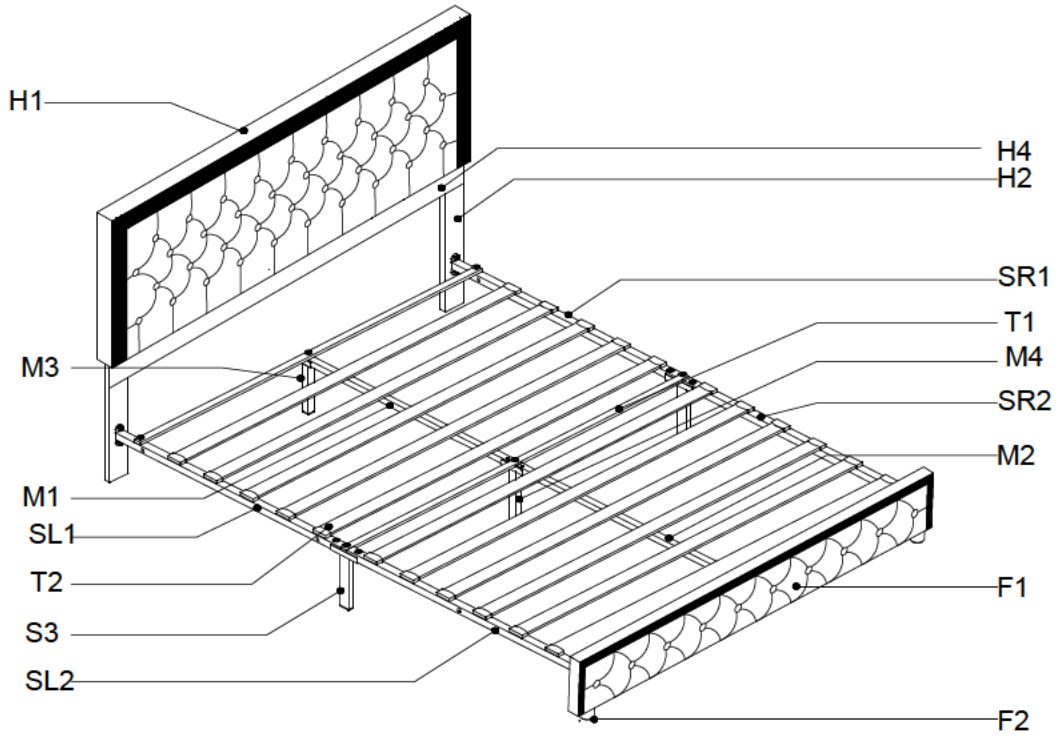

Si tiene algún problema con su producto o pedido, póngase en contacto con nosotros antes de consultar con el servicio de atención al cliente de Platform, le resolveremos su problema con mayor brevedad. ¡  
Reemplazamos  
piezas perdidas o dañadas enviándolas rápidamente

For any questions, please contact [SibedsAfterService@outlook.com](mailto:SibedsAfterService@outlook.com)  
-we will help you.

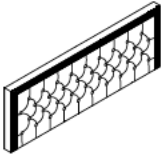

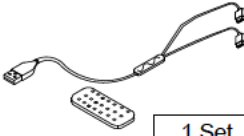
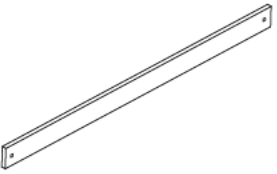
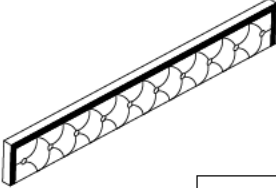

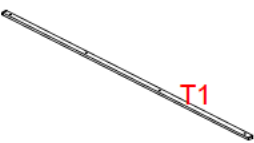

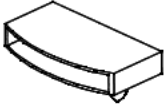
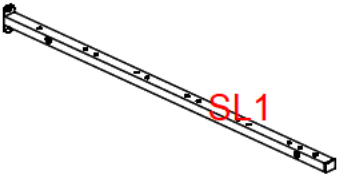
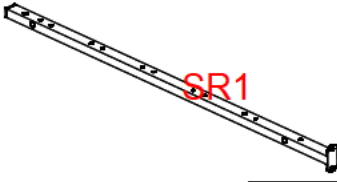
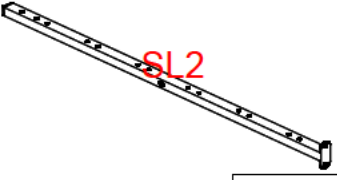
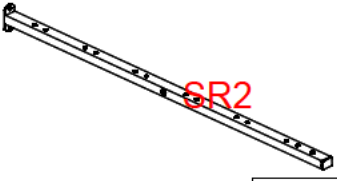
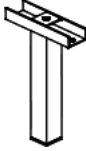
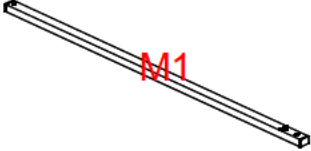
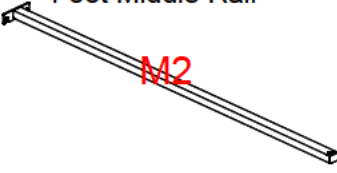
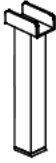
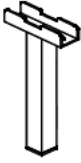
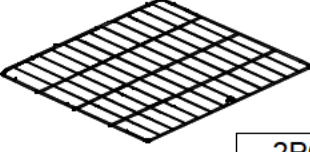
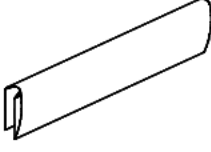

## Assembly Instruction of (Bed)

Drawers shown separately

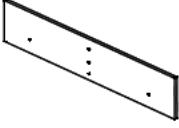
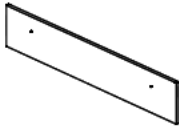
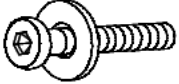

H1	Headboard	H2	Headboard Leg	H3	Connecting cable and LED remote control	H4	Headboard baffle
							
	1PC		2PCS		1 Set		1PC
F1	Footboard	F2	Footboard Feet	T1	Cross Beam	T2	Slat
							
	1PC		2PCS		2PCS		11PCS

## Assembly Instruction of (Bed)

<p>T3 Slat Anchor Clip</p>  <p style="text-align: right;">22+2PCS</p>	<p>SL1 Head Side Rail Section</p>  <p style="text-align: right;">1PC</p>	<p>SR1 Head Side Rail Section</p>  <p style="text-align: right;">1PC</p>
<p>SL2 Foot Side Rail Section</p>  <p style="text-align: right;">1PC</p>	<p>SR2 Foot Side Rail Section</p>  <p style="text-align: right;">1PC</p>	<p>S3 Center Side Rail Leg</p>  <p style="text-align: right;">2PCS</p>
<p>M1 Head Middle Rail</p>  <p style="text-align: right;">1PC</p>	<p>M2 Foot Middle Rail</p>  <p style="text-align: right;">1PC</p>	<p>M3 Head Middle Leg</p>  <p style="text-align: right;">1PC</p>
<p>M4 Central Middle Leg</p>  <p style="text-align: right;">1PC</p>	<p>D1 Drawer Grid Base</p>  <p style="text-align: right;">2PCS</p>	<p>D2 Fabric Drawer Shell</p>  <p style="text-align: right;">2PCS</p>
<p>D3 Drawer Caster</p>  <p style="text-align: right;">8PCS</p>	<p>D4 Drawer Panel</p>  <p style="text-align: right;">2PCS</p>	<p>D5 Side Panel</p>  <p style="text-align: right;">2PCS</p>
<p>U1 M8×45mm Screw with Washer</p>  <p style="text-align: right;">20+2PCS</p>	<p>U2 M6×15mm Screw with Washer</p>  <p style="text-align: right;">8+1PCS</p>	<p>U3 M6×15mm Screw</p>  <p style="text-align: right;">4PCS</p>
<p>U8L M8 L-Wrench</p>  <p style="text-align: right;">1PC</p>	<p>U6L M6 L-Wrench</p>  <p style="text-align: right;">1PC</p>	<p>W Light Bar Fixer</p>  <p style="text-align: right;">4PCS</p>

## Assembly Instruction of (Bed)

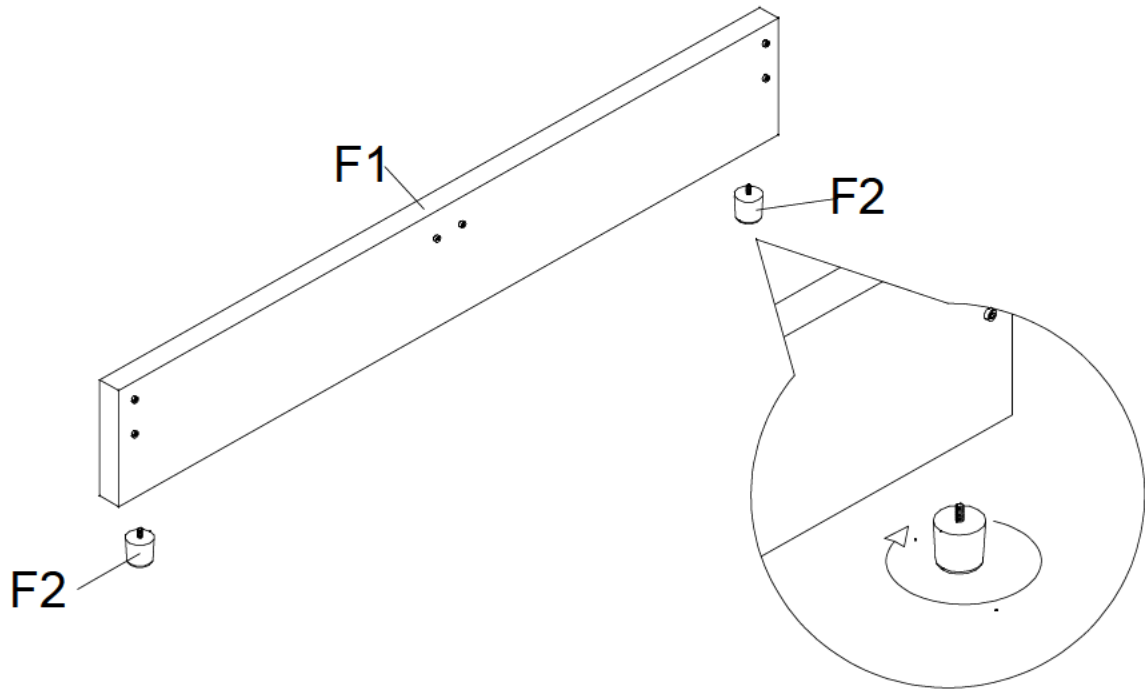

### STEP 1

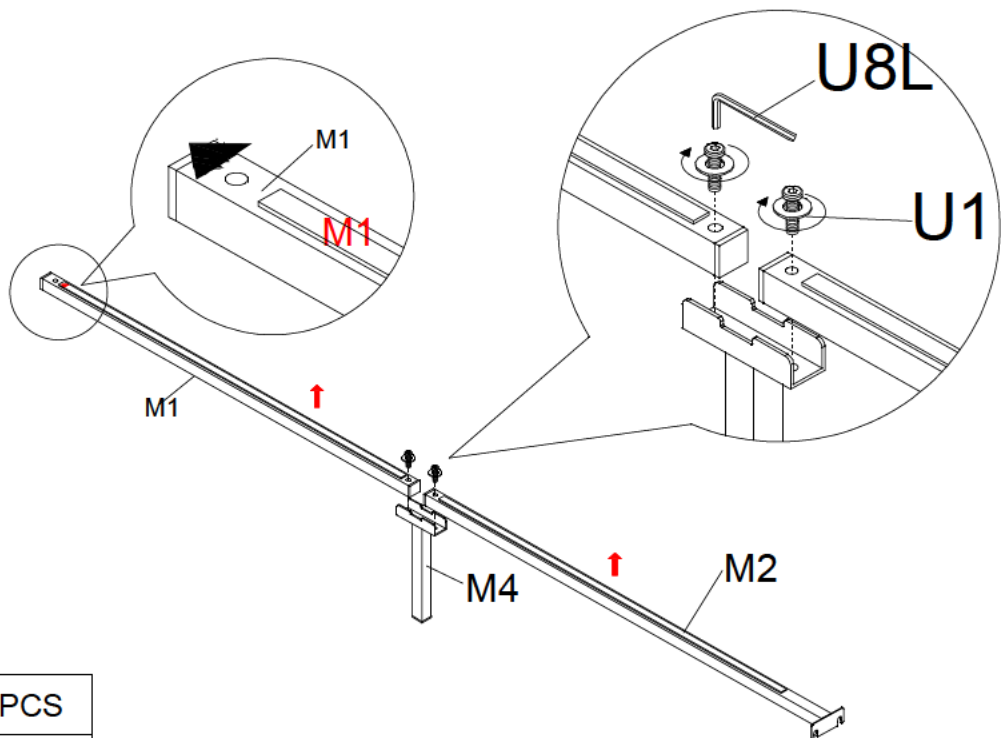

### STEP 2

Noted that the middle cross beam,  
the direction of the black arrow is the front





	U1 x 2PCS
	U8L x 1PC

Screws with small round pieces will make the bed more stable.

## Assembly Instruction of (Bed)

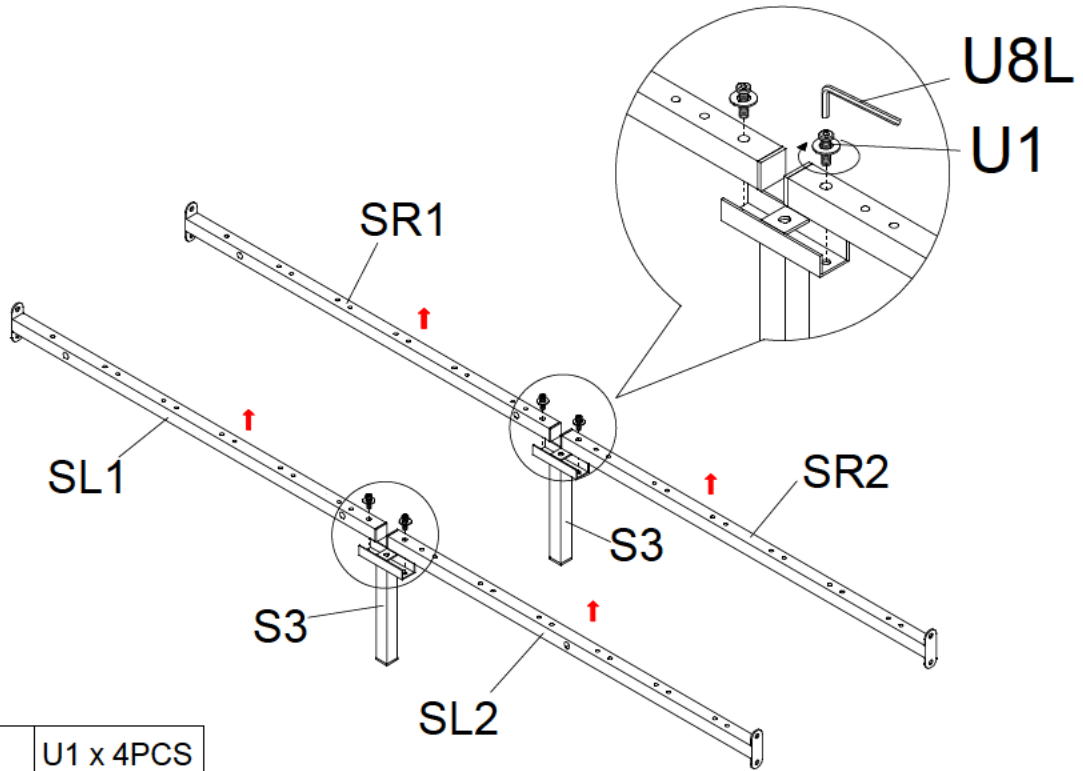
### STEP 3



	U1 x 4PCS
	U8L x 1PC

Screws with small round pieces will make the bed more stable.

### STEP 4

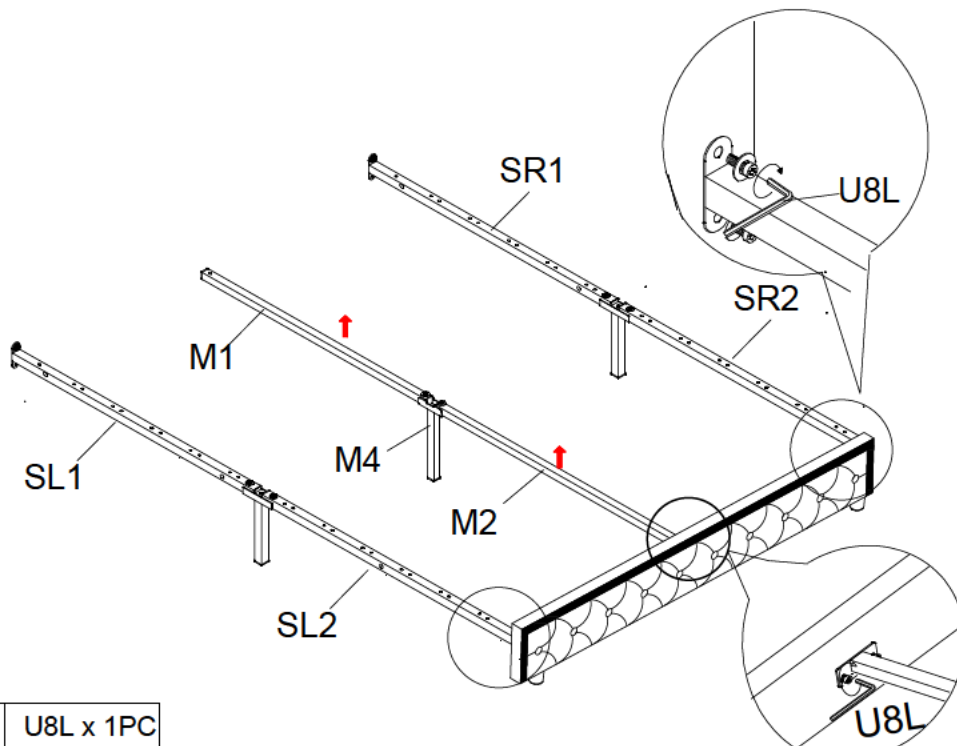

	U8L x 1PC
-------------------------------------------------------------------------------------	-----------

# Assembly Instruction of (Bed)

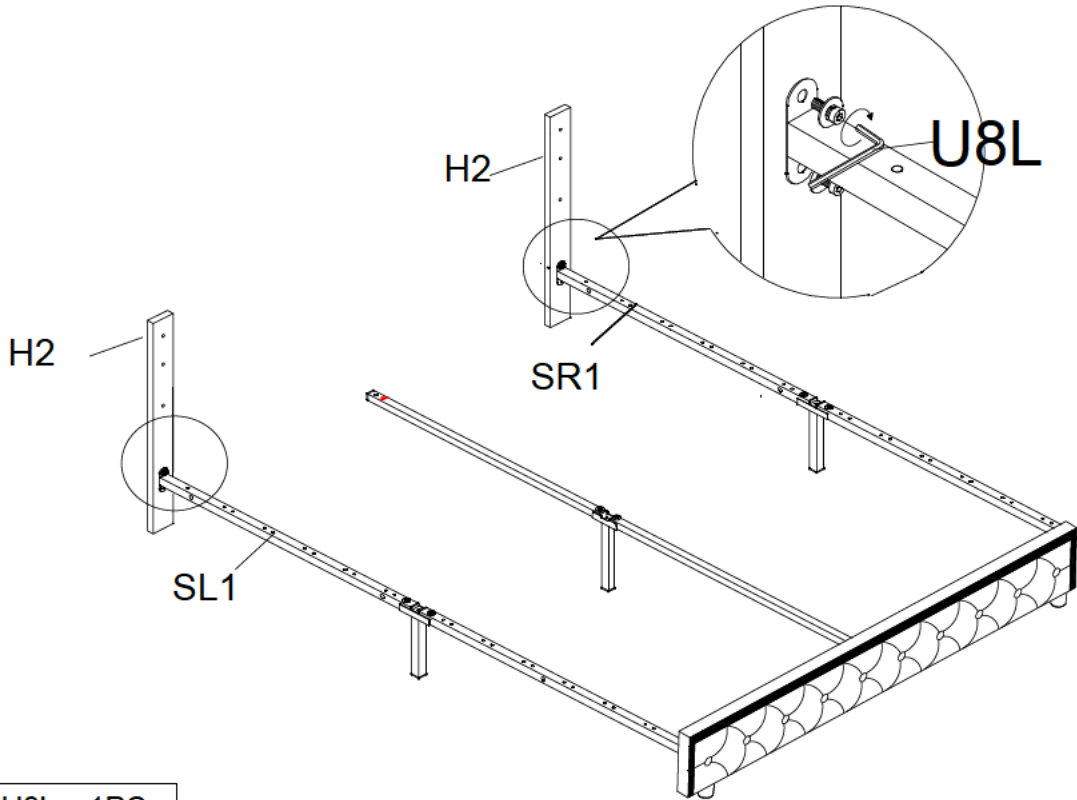

## STEP 5

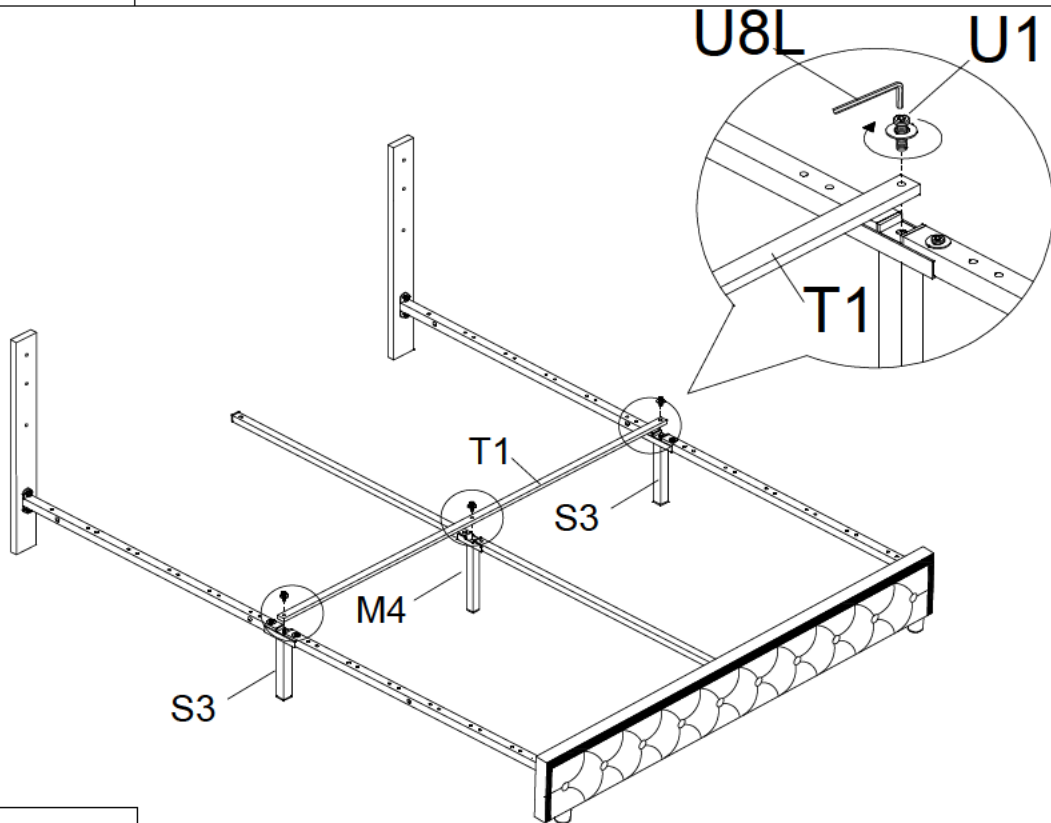

	U8L x 1PC
-------------------------------------------------------------------------------------	-----------

## STEP 6





	U1 x 3PCS
	U8L x 1PC

Screws with small round pieces will make the bed more stable.

# Assembly Instruction of (Bed)

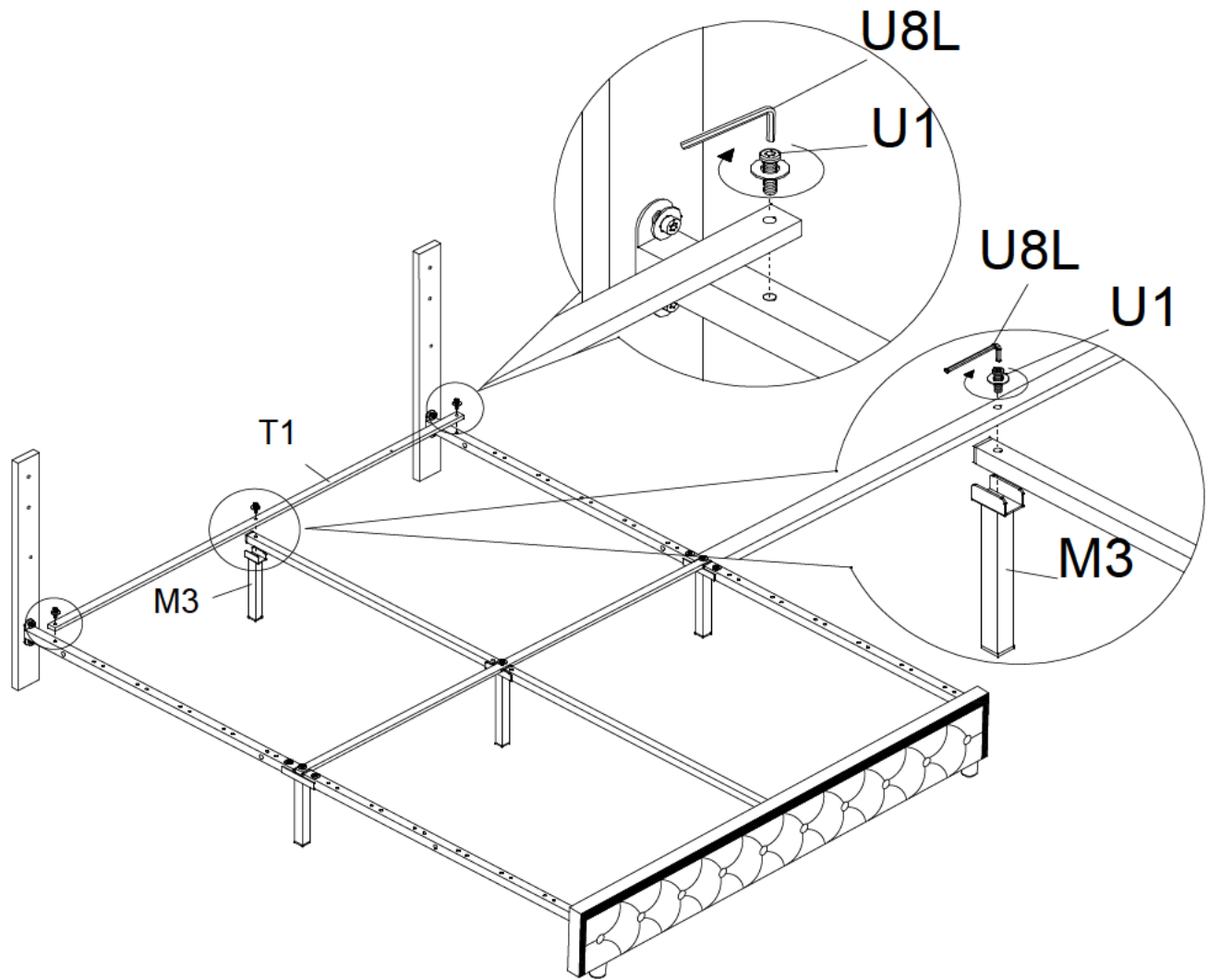
## STEP 7





	U1 x 3PCS
	U8L x 1PC

Screws with small round pieces will make the bed more stable.

## Assembly Instruction of (Bed)

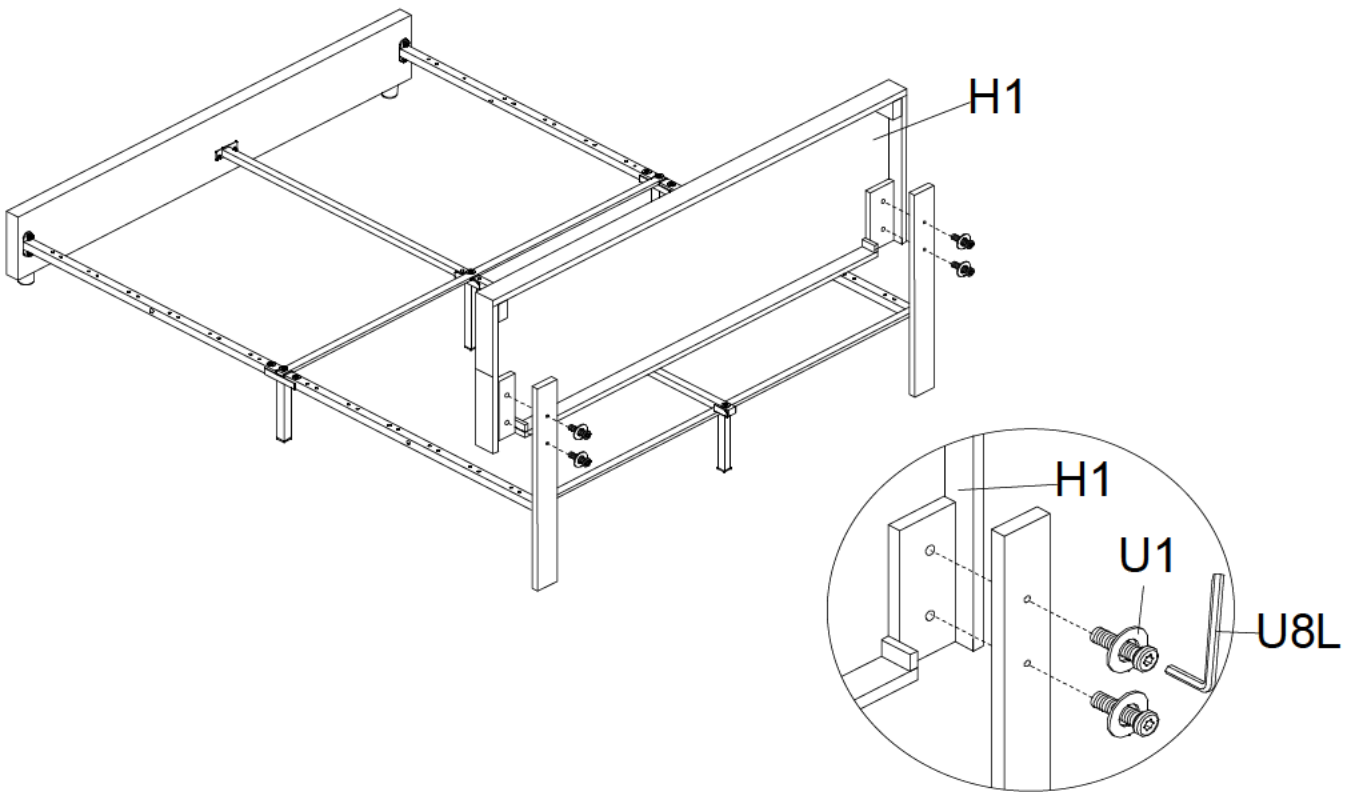
**STEP 8** **IMPORTANT** : The washers are crucial for a tight fit. Do not forget to use them with the screws.



	U1 x 4PCS
	U8L x 1PC

# Assembly Instruction of (Bed)

## STEP 9

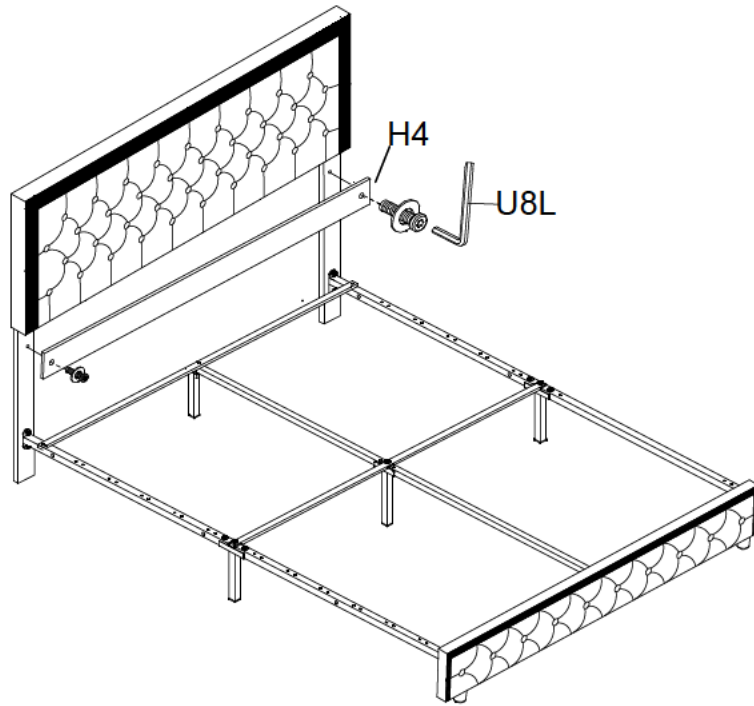

U8L x 1PC

## STEP 10

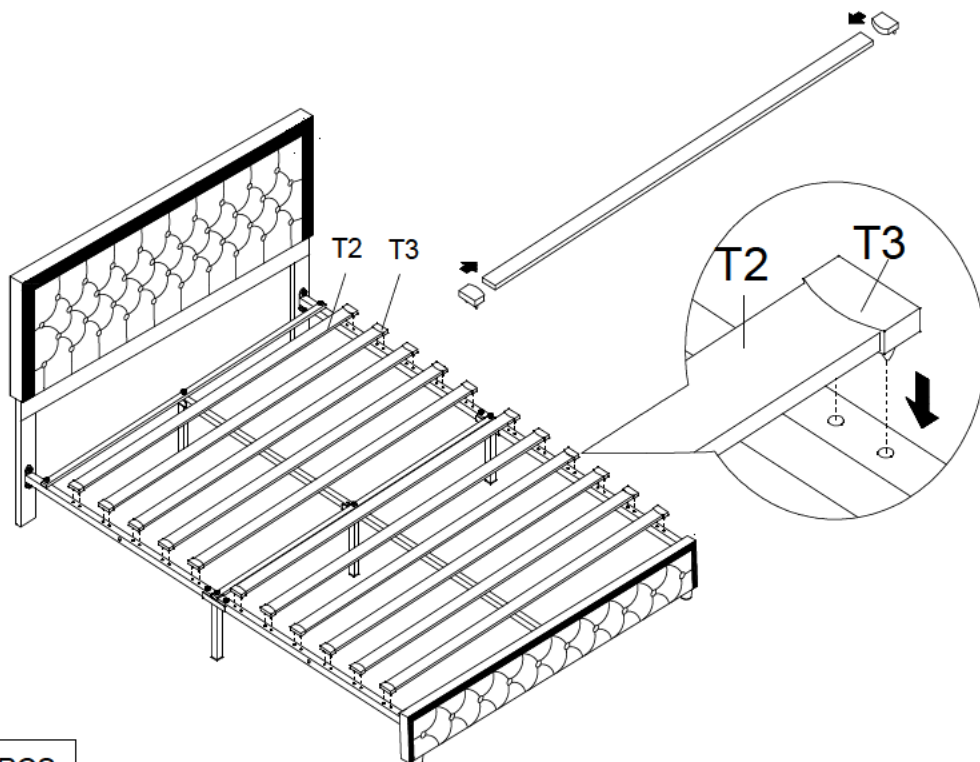

T3 X 22PCS

# Assembly Instruction of (Bed)

## STEP 11

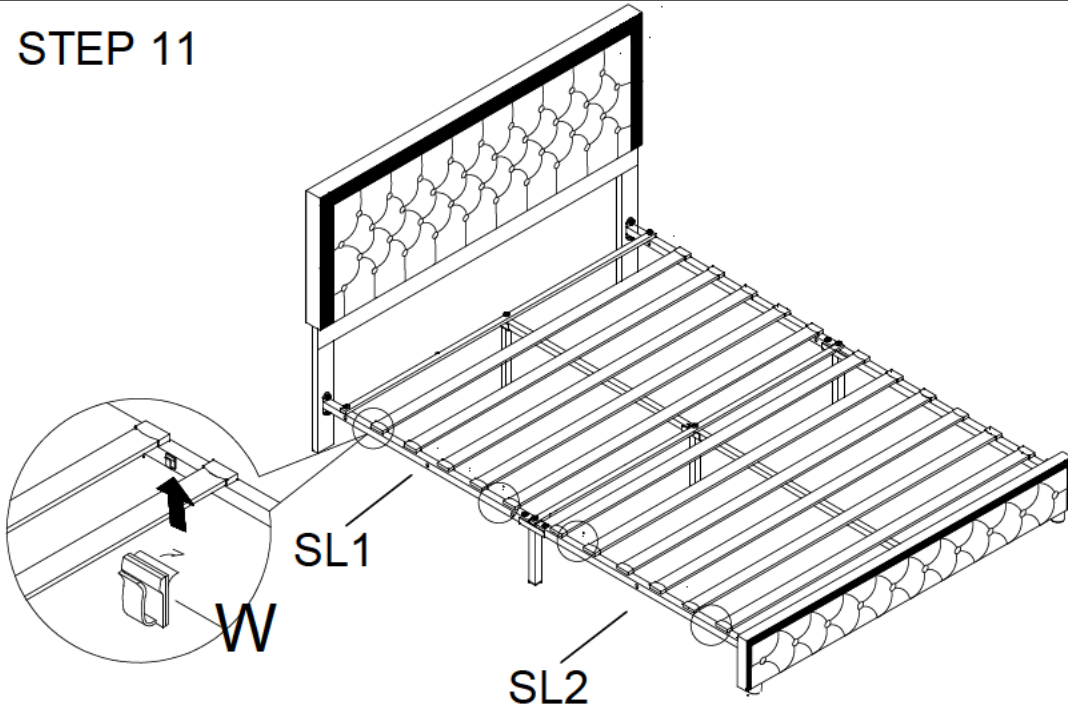

W x 4PCS

## STEP 12

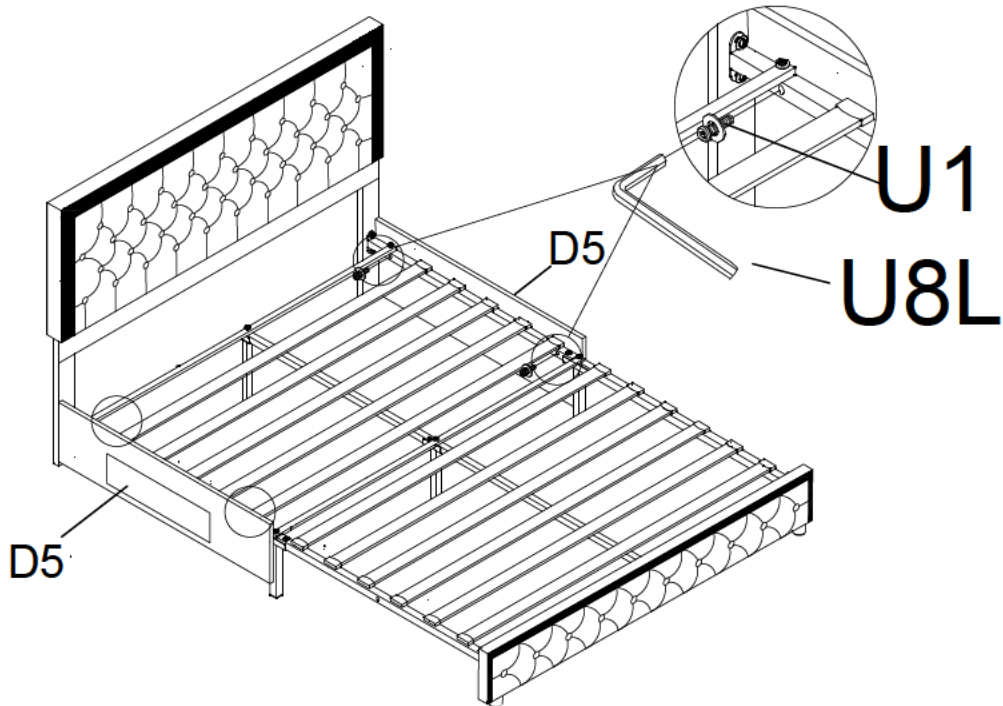

U1 x 4PCS



U8L x 1PC

# Assembly Instruction of (Bed)

## STEP 13

The hocks need to be attached to the inside of the frame

Tips: To prevent separation at the joint, the tape can be wrapped around the joint.

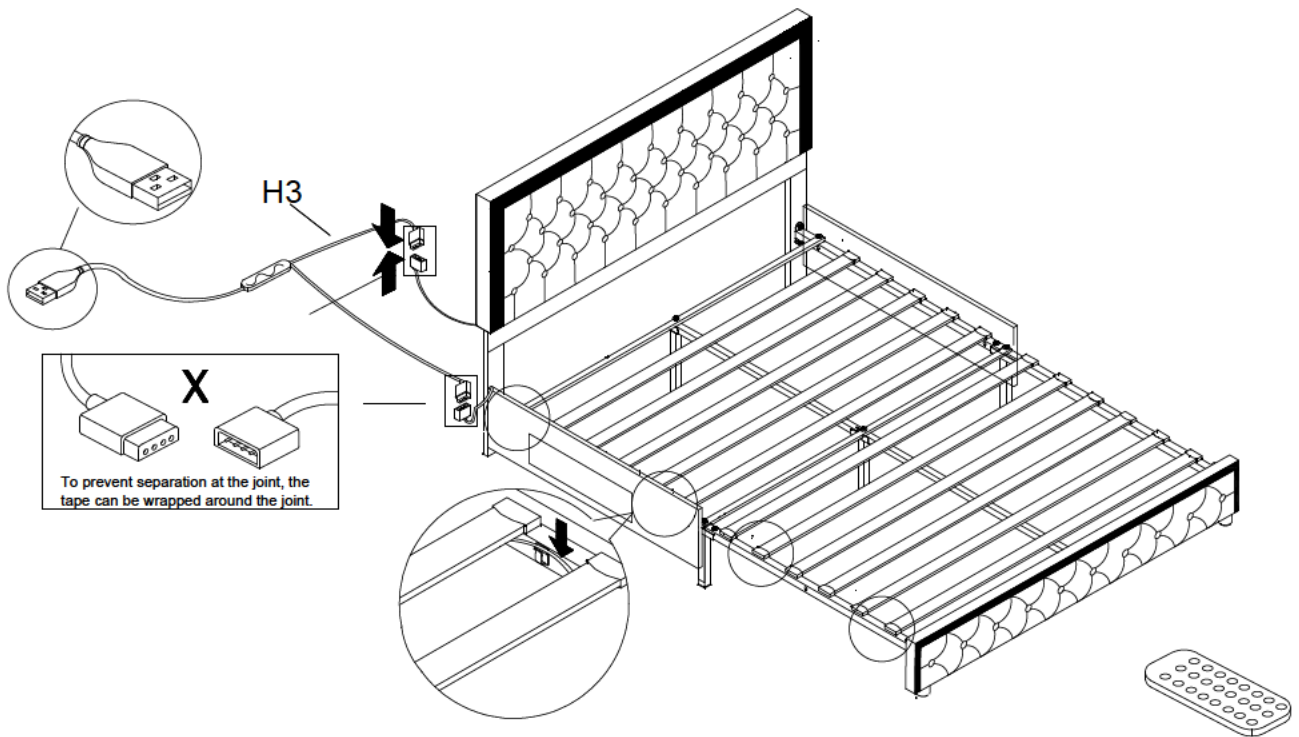

Please scan the QR code on the manual/controller and install the application.  
Step1: Please make sure that Bluetooth is enabled on your device  
Step2: The LED light will automatically connect to the APP



H3 X 1SET

# Assembly Instruction of (Drawer)

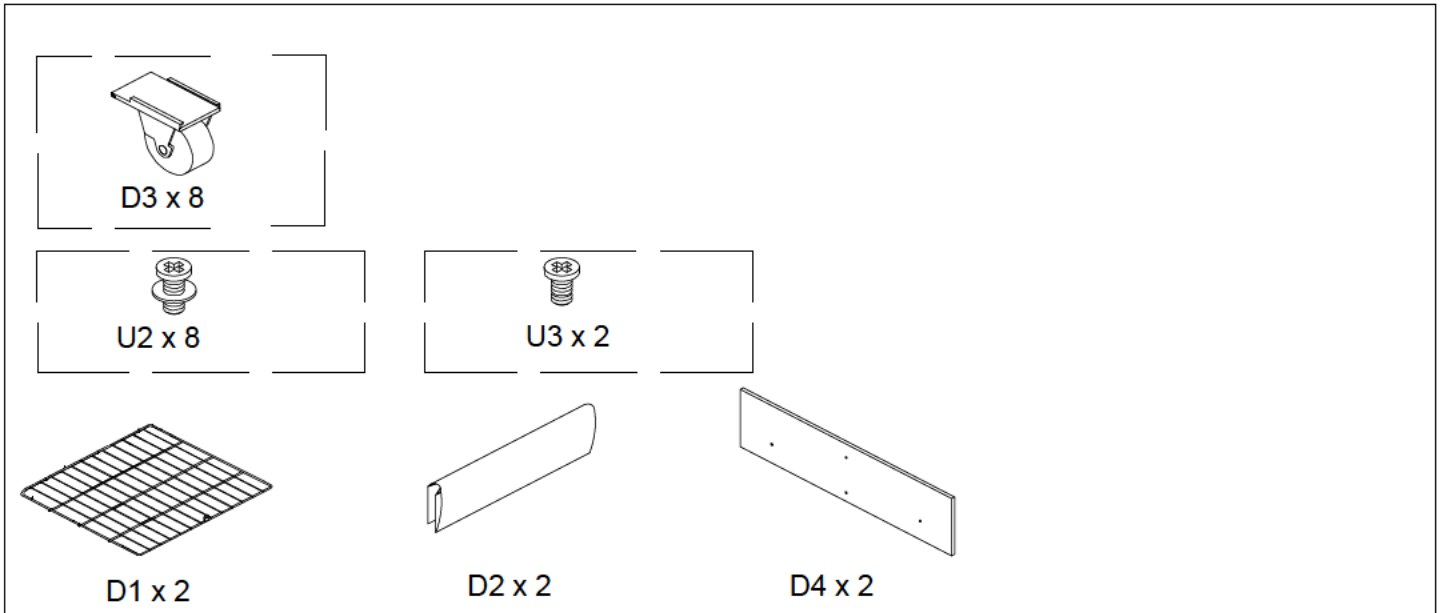

## STEP 14

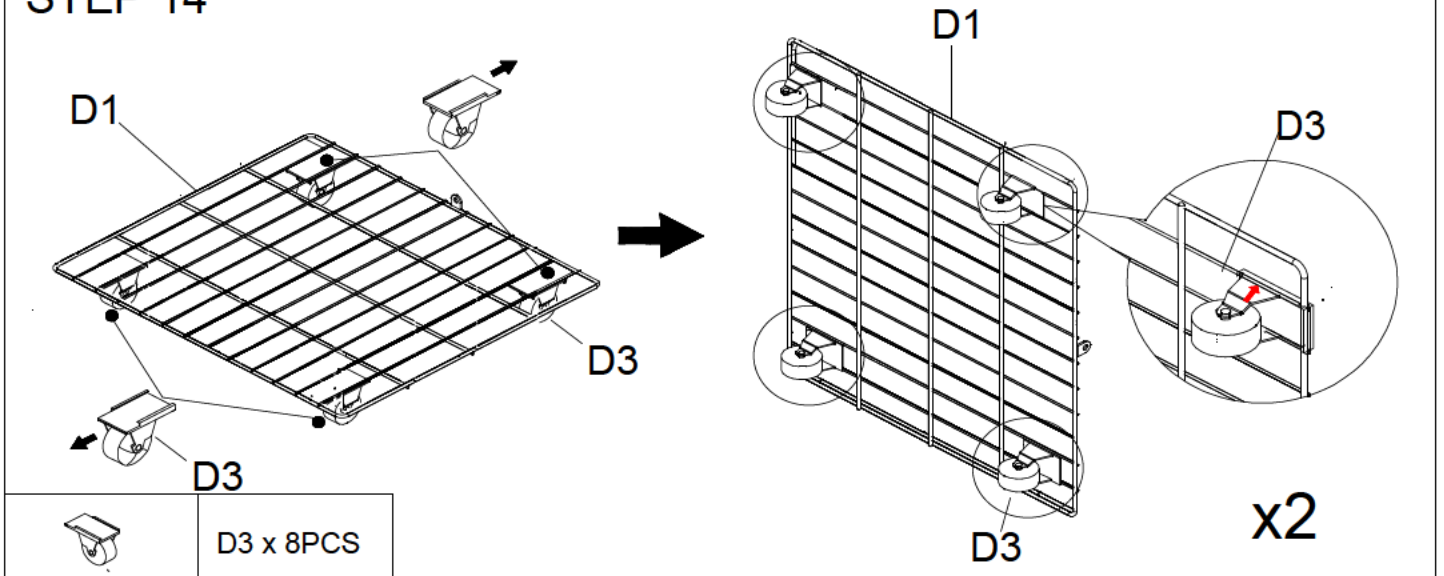

## STEP 15

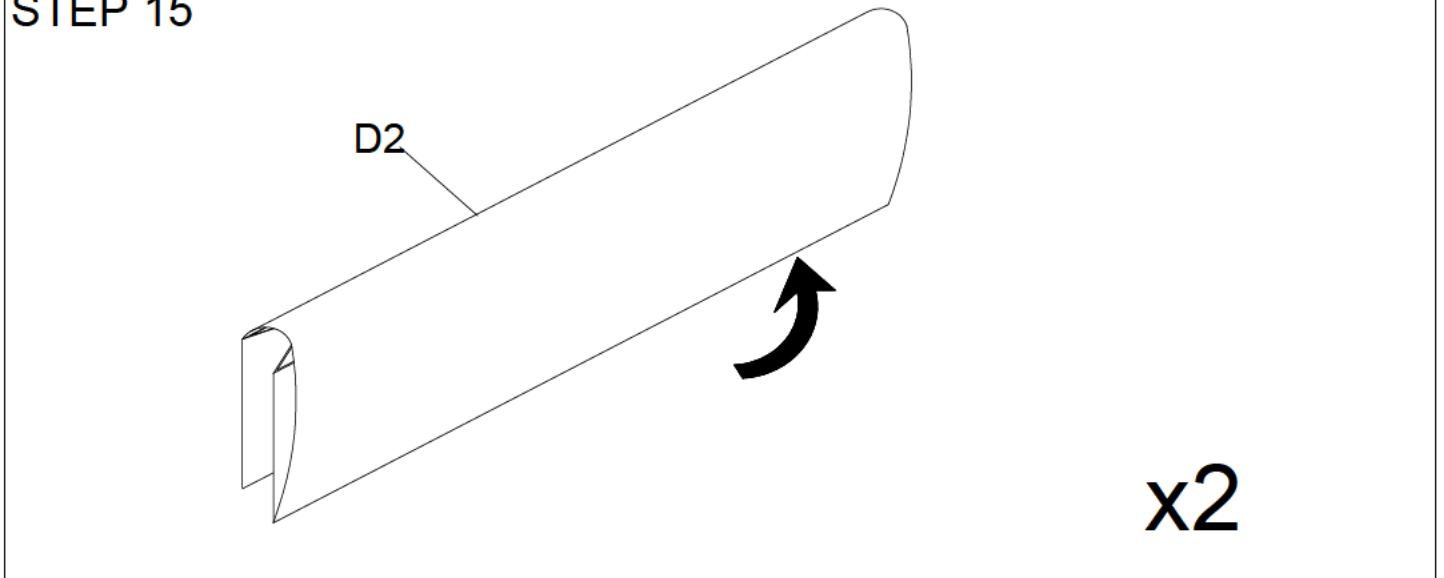

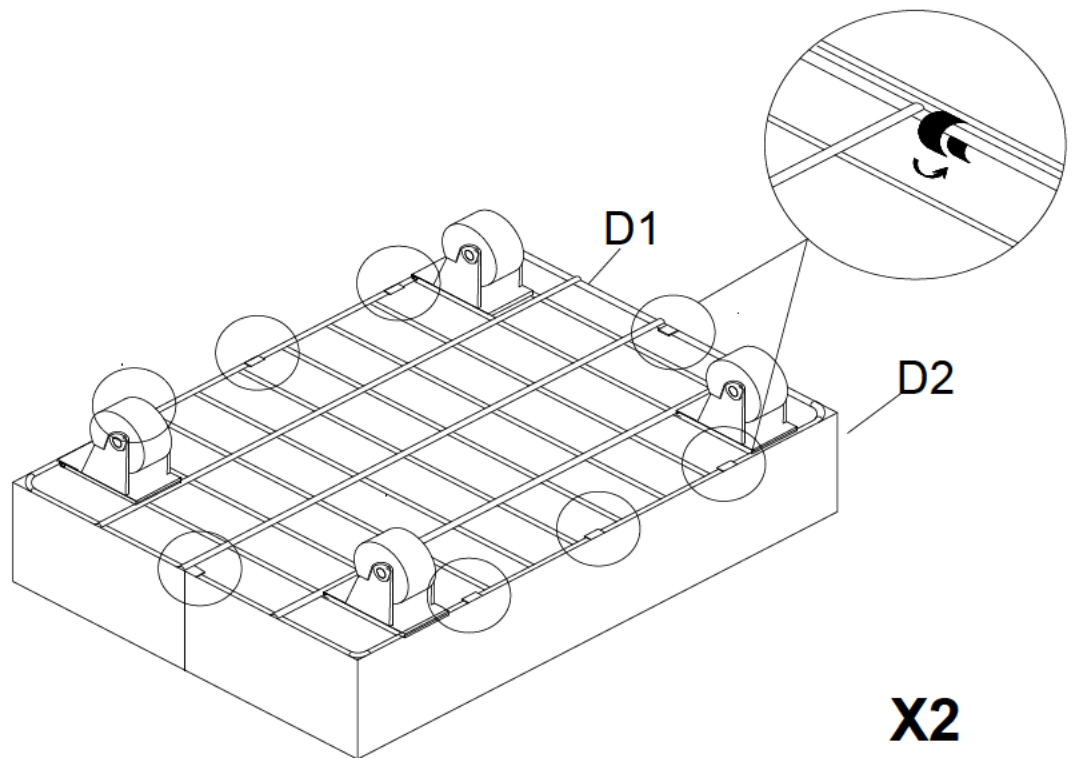

# Assembly Instruction of (Drawer)

## STEP 16

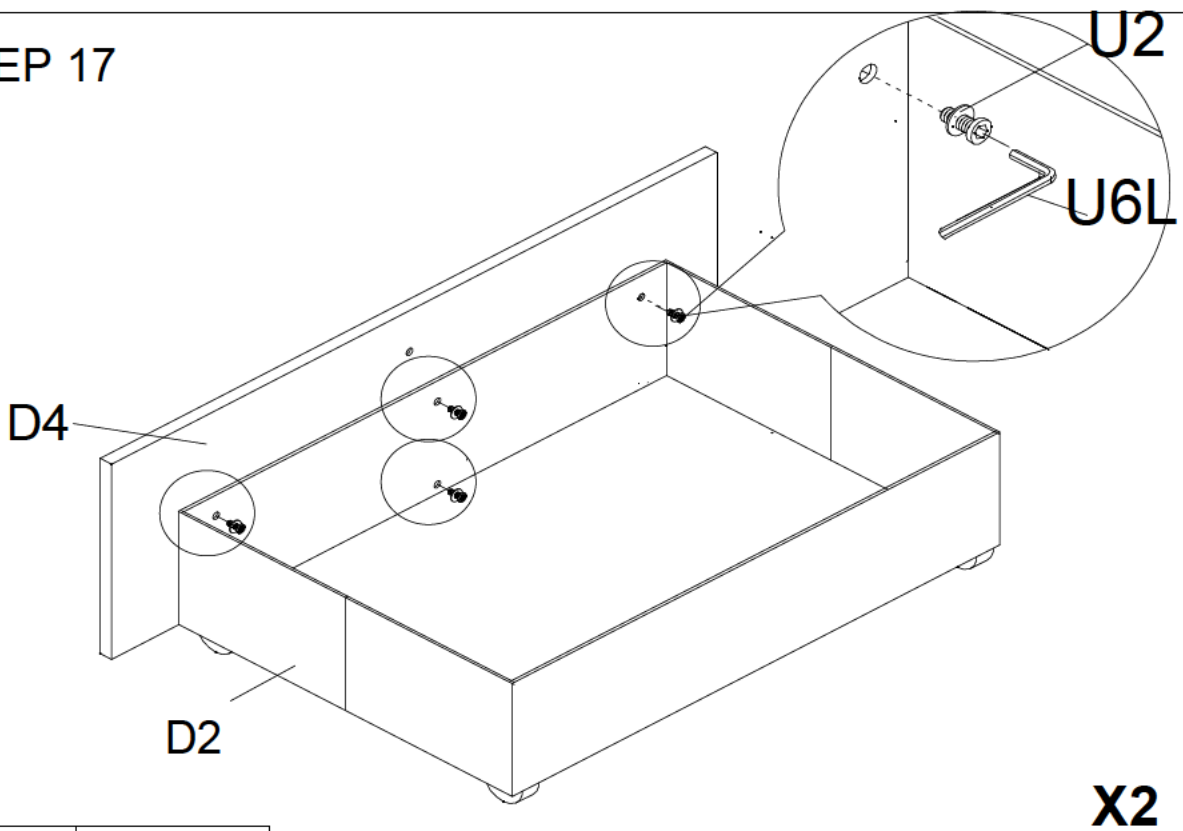

## STEP 17





	U2 x 8PCS
	U6L x 1PC

## Assembly Instruction of (Drawer)

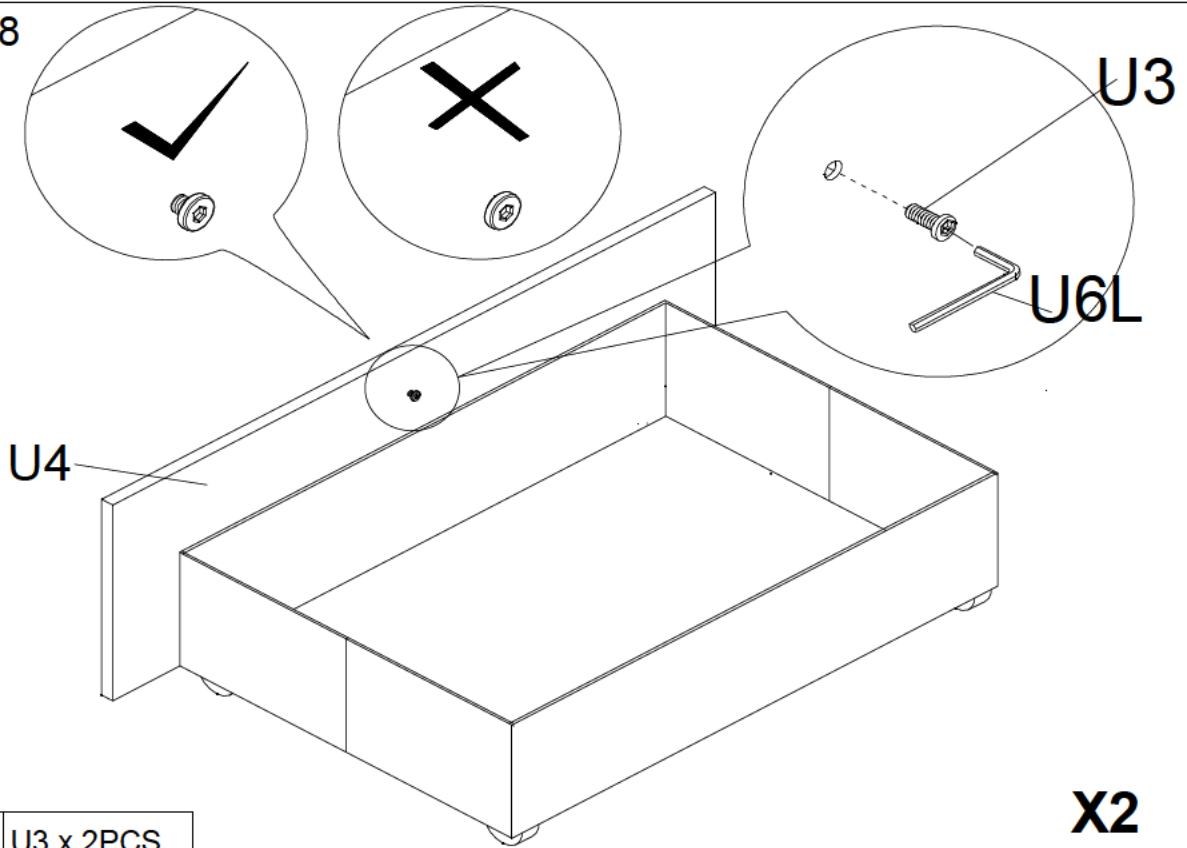
STEP 18



	U3 x 2PCS
	U6L x 1PC

STEP 19 Drawer panel screw hang into side cross beam hole.

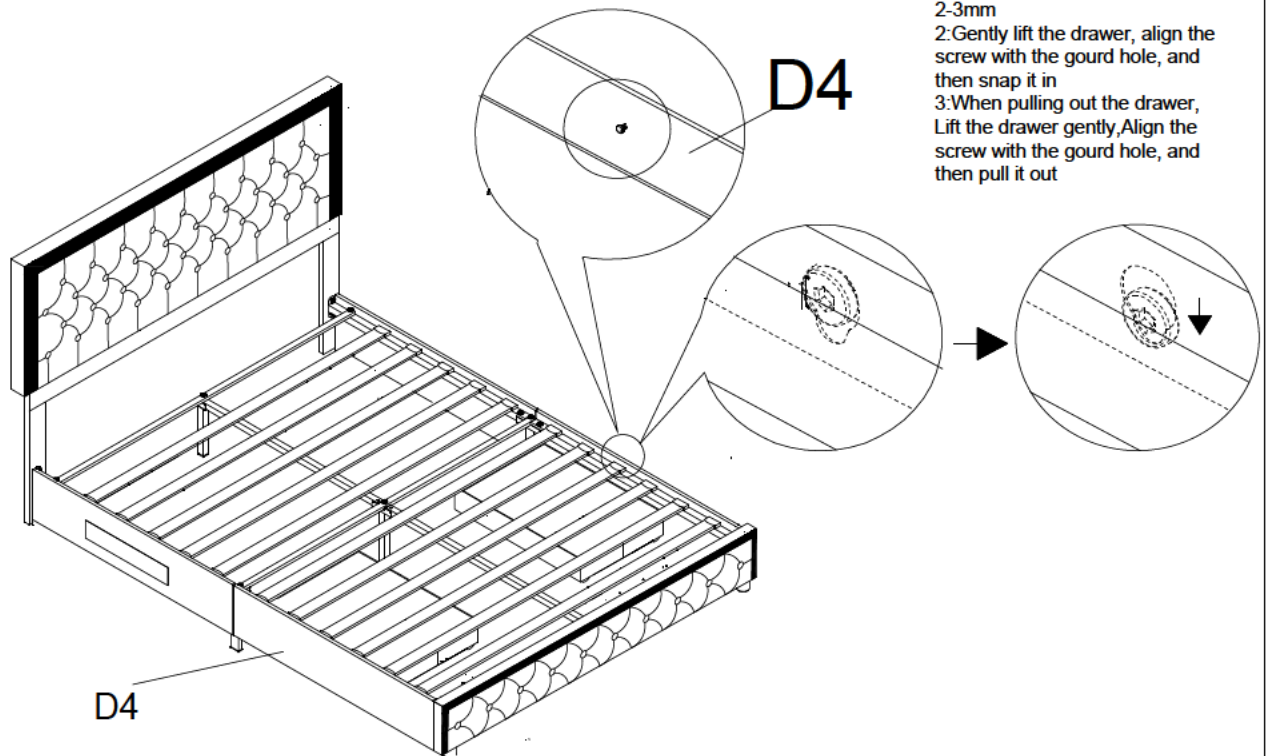

- 1: This screw must be turned out slightly, leaving a distance of 2-3mm
- 2: Gently lift the drawer, align the screw with the gourd hole, and then snap it in
- 3: When pulling out the drawer, lift the drawer gently, align the screw with the gourd hole, and then pull it out