

VIVOHOME

**THANK
YOU!**

NOTE:

To continuously improve its products, VIVOHOME reserves the right to modify this information without prior notification.

For any questions regarding assembly, please watch the video on the product page or contact our customer service. Our customer service will gladly assist you with any additional questions, comments, or concerns.

Thank you for using VIVOHOME products in your home!

Thank You for Purchasing from

VIVOHOME

Made in China

VIVOHOME

HOW-TO

USER MANUAL

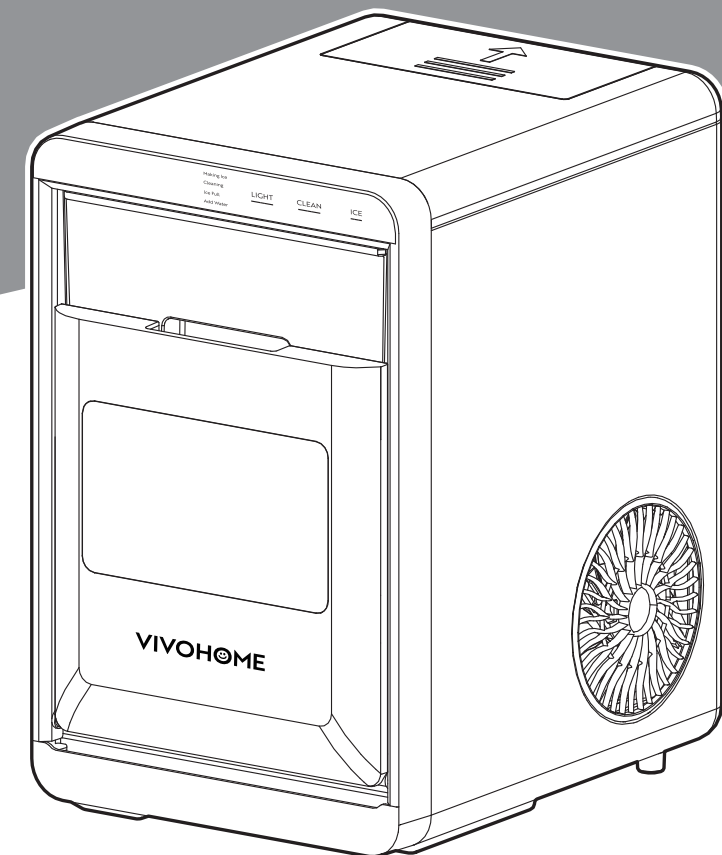

Countertop Nugget Ice Maker

Assembly is EASY!

**WE WANT
YOU TO
ENJOY LIFE
AT HOME**

GO TO THE PRODUCT LISTING PAGE FOR
AN INSTRUCTIONAL VIDEO!



CONTENTS

- Important Safety Instruction**1
- Preparing Your Ice Maker For Use**2
 - Important Safety Tips2
- Getting to Know Your Unit**4
- Operating Procedures & Maintenance**5
- Using Your Ice Maker**6
 - How to Start the Unit6
 - Operation and Display Areas7
 - System Cleaning/Sanitizing Procedure.....8
 - How to Obtain the Ice-cube11
 - Tips11
- Troubleshooting**.....12
- Technical Parameters**13
- Circuit Diagram**13
- Warranty**14

*** After receiving the machine, it needs to be left to stand for 24 hours.**

Your safety and the safety of others are very important. We have provided many important safety messages in the manual for your appliance. Always read and obey all safety messages.

This is the safety alert symbol: 

All safety messages will follow the safety alert symbol and the word "DANGER" or "WARNING".



These words mean:

You can be killed or seriously injured if you don't immediately follow instructions.

All safety messages will tell you what the potential hazard is, tell you how to reduce the chance of injury, and tell you what can happen if the instructions are not followed.



IMPORTANT SAFETY TIPS

When using electrical appliances, basic safety precautions should be followed to reduce the risk of fire, electric shock, and injury to persons or property. Read all instructions before using any appliance.

1. Do not operate this, or any other appliance with a damaged cord. If the supply cord is damaged, it must be replaced by the manufacturer, its service agent, or a similarly qualified person in order to avoid a hazard.
This ice-maker must be positioned so that the plug is accessible.
Connect to properly grounded outlets only. No other appliance should be plugged into the same outlet. Be sure that the plug is fully inserted into the receptacle.
2. Do not run the power cord over carpeting or other heat insulators. Do not cover the cord. Keep cords away from traffic areas, and do not submerge in water.
3. We do not recommend the use of an extension cord, as it may overheat and become a risk of fire. If you must use an extension cord, use No. 14AWG minimum size and rated at no less than 1875 watts.
4. Unplug the ice maker before cleaning or making any repairs or servicing.
5. Exercise caution and use reasonable supervision when appliance is used near children.
6. Do not use your ice-maker outdoors. Place the ice-maker away from direct sunlight and make sure that there is at least 6 inches of space between the back of your unit and the wall. Keep a minimum distance of 6 inches on each side of your unit free.
7. Do not use any other liquid to make the ice-cube other than water.
8. Do not clean your ice maker with flammable fluids. The fumes can create a fire hazard or explosion.
9. Do not tip over.
10. If the ice maker is brought in from outside in wintertime, give it a few hours to warm up to room temperature before plugging it in.

WARNING: This appliance must be earthed.

11. **DANGER - Risk Of Fire or Explosion.** Flammable Refrigerant Is Used. Do Not Use Mechanical Devices To Defrost Ice Maker. Do Not Puncture Refrigerant Tubing.
12. **DANGER - Risk Of Fire Or Explosion.** Flammable Refrigerant Is Used. To Be Repaired Only By Trained Service Personnel. Do Not Puncture Refrigerant Tubing.
13. **CAUTION - Risk Of Fire Or Explosion.** Flammable Refrigerant Is Used. Consult Repair Manual/Owner's Guide Before Attempting To Install or Service This Product. All Safety Precautions Must be Followed.
14. **CAUTION - Risk Of Fire Or Explosion.** Dispose Of Property In Accordance With Federal Or Local Regulations. Flammable Is Refrigerant Used.
15. **CAUTION - Risk Of Fire Or Explosion Due To Puncture Of Refrigerant Tubing;** Follow Handling Instructions Carefully. Flammable Refrigerant Is Used.
16. The ice maker should be installed in accordance with the safety standard for Refrigeration Systems, ASHRAE15. The ice maker shall not be installed in corridors or hallways of public buildings.
17. If the unit has problems and needs to be maintained, replacement with like components and servicing shall be done by factory-authorized service personnel so as to minimize the risk of possible ignition due to incorrect parts or improper service.

IMPORTANT:

The wires in this mains lead are colored in accordance with the following code:

Green or Green with a strip yellow: Grounding

White: Neutral

Black: Live

To avoid a hazard due to instability of the appliance, it must be placed at a even or flat surface.

Getting To Know Your Unit



1. Control Panel.
2. Cover for water tank.
3. Water tank.
4. Ice basket.
5. Flip door.
6. Window.
7. Drip tray.
8. Cover for secondary water tank.
9. Secondary water tank.
10. Hot Air outlet.
11. Rear Panel.
12. Power cord.

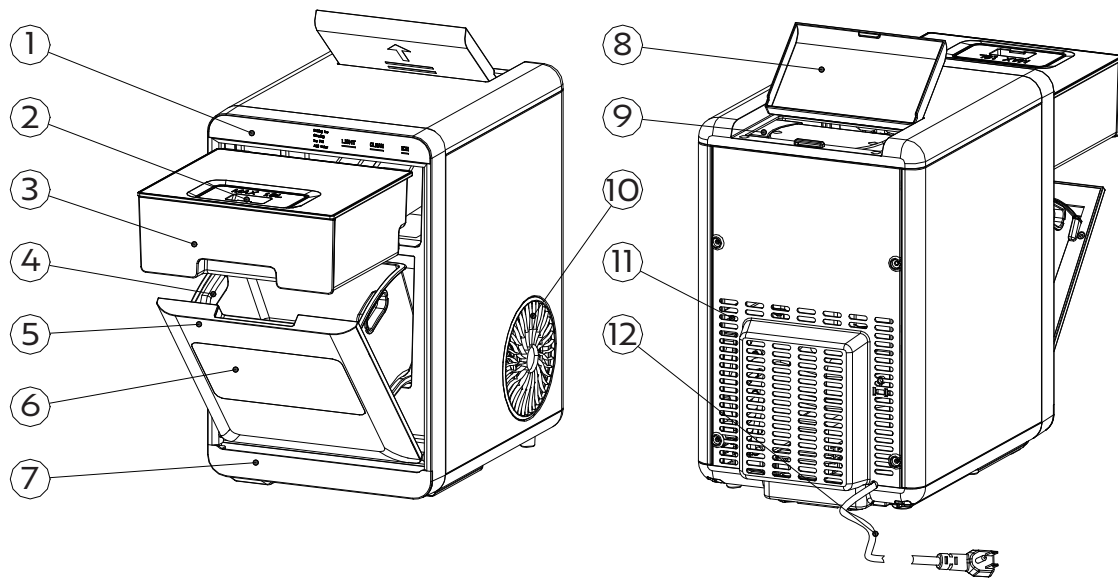

Operating Procedures & Maintenance



1. Remove the exterior and interior packaging, and then check that all the accessories are included. If any parts are missing, please contact our customer service.
2. Remove all the tapes on the unit; take out the accessory parts inside.
3. Clean the interior with lukewarm water and a soft cloth.
4. Locating your ice maker on a level counter table far from direct sunlight and other sources of heat (i.e., stove, furnace, and radiator). Make sure that there is at least 6 inches between the back and sides of your ice maker and the wall.
5. Allow one hour for the refrigerant fluid to settle down before plugging your ice maker in.
6. The power plug must be accessible directly.

WARNING: fill with potable water only. Only use drinking water.



*Improper use of the grounded plug can result in the risk of electrical shock. If the power cord is damaged, please call our customer service.

1. This unit should be properly grounded for your safety. The power cord of this appliance is equipped with a grounding plug that mates with standard grounding wall outlets to minimize the possibility of electric shock.
2. Plug your appliance into an exclusive, properly installed, grounding wall outlet. Do not under any circumstances, damage the grounding means of the plug. Any questions concerning power and/or grounding should be directed toward a certified electrician.
3. This appliance requires a standard 110-120Volt, 60Hz electrical outlet with good grounding means.



Before using your ice maker, it is strongly recommended to clean it thoroughly.

Unplug the unit before cleaning or making any maintenance.

1. Take out the ice basket.
2. Clean the interior with diluted detergent, warm water and a soft cloth.
3. Then use the water to rinse the inside parts, and drain out the water by unplugging the drain cap on the front bottom side.
4. The outside of the ice maker should be cleaned regularly with a mild detergent solution and warm water.
5. Dry the interior and exterior with a clean soft cloth.
6. When the machine is not to be used for a long time, drain water completely & dry the interior.

How to start the unit

1. Pour potable water into a water reservoir, containing 0.47 gallon (1.8 liters) of water at most at one time.
2. Open the flip door, pull out half of the water tank, flip open the lid of the water tank, then inject water, and after the injection is complete, push the water tank forward until it is in position.
Note: Please make sure that the water tank is pushed in place; otherwise, it may show a water shortage!
3. Plug in the power cord.

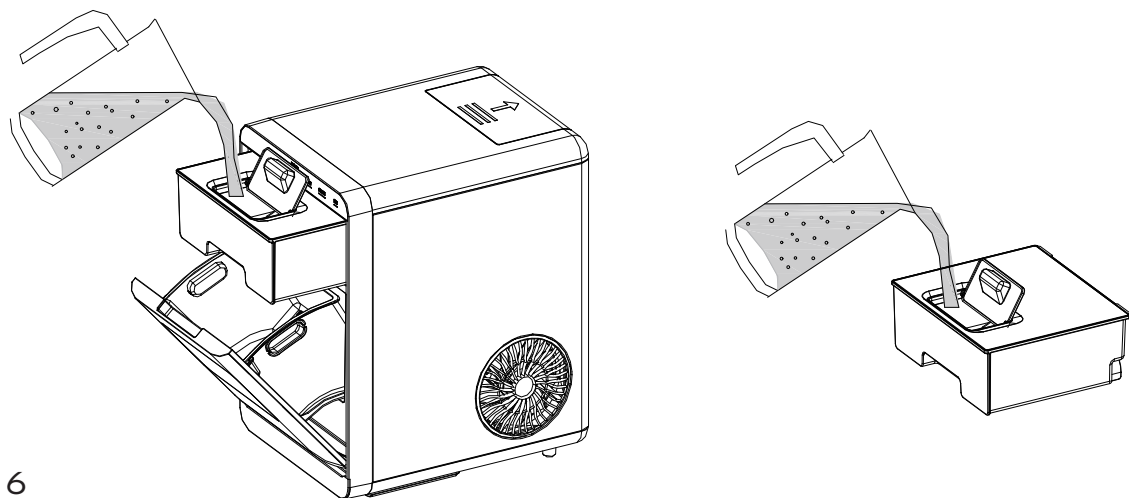

Operation and Display Areas

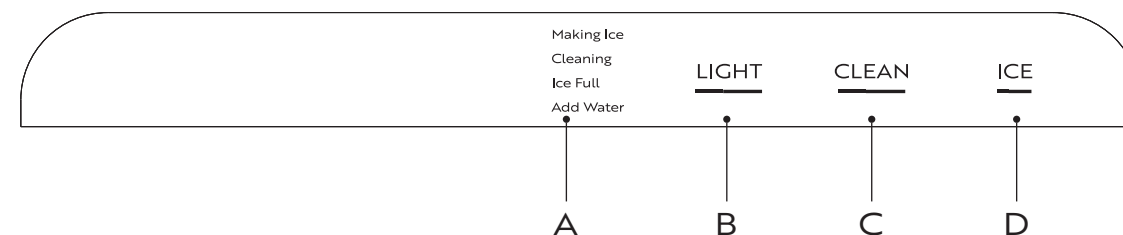

A: Status indicator
C: CLEAN button

B: LIGHT button
D: ICE button

Plug in the power cord, the screen is on, and you can operate this appliance by touching the button on the panel as shown above. The main functions include ice, cleaning, and light.

System Cleaning/Sanitizing Procedure

1. Unplug the nugget ice maker.

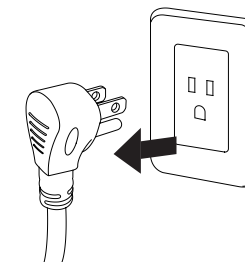

2. Clean the water reservoir and internal water tanks with a soft brush.

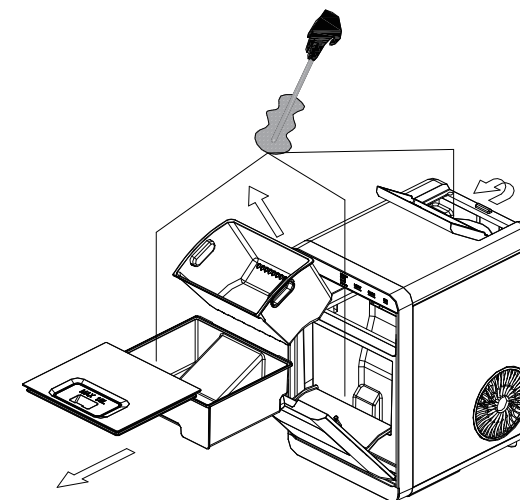

3. Take off the bottom drain cap and drain out the water to a sink. See the figure below.

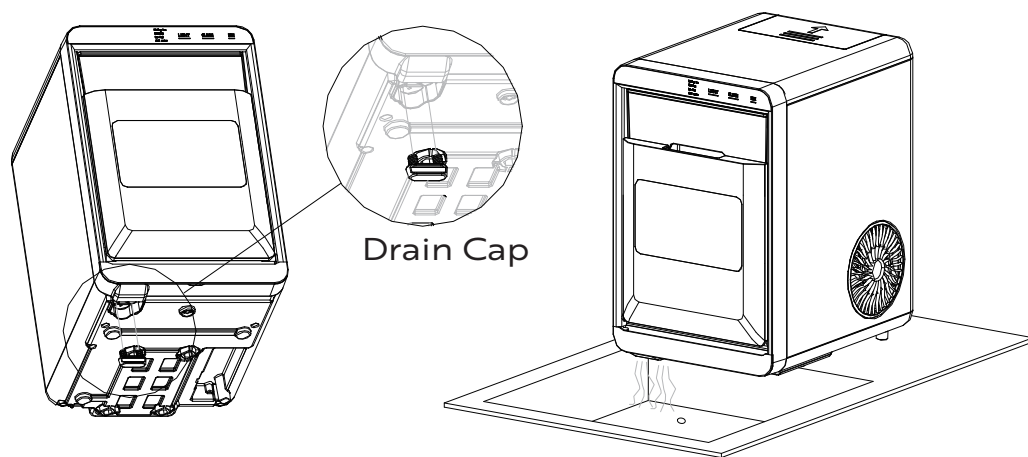

4. Pour the solution into the water reservoir (1.8 L at most). See the figure below.

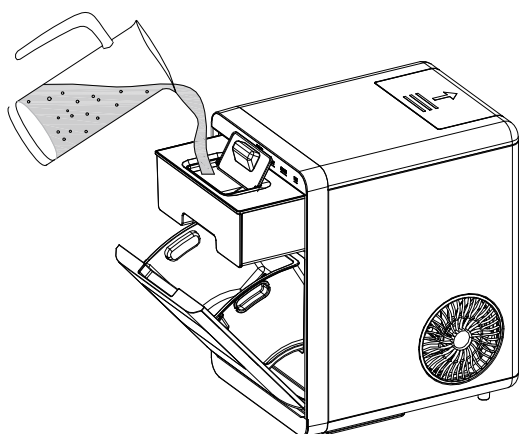

5. Plug in the Nugget ice maker, press the "CLEAN" button to initiate the cleaning process (20 minutes). See the figure below.

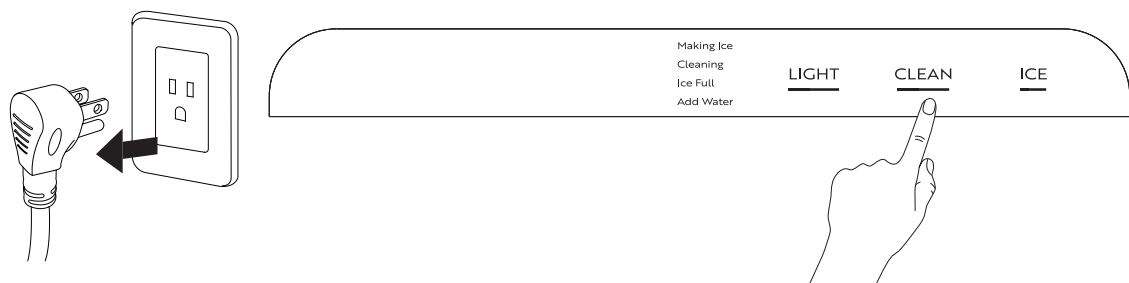

6. When the "cleaning" indicator lights off, take off the drain cap and drain the water to a sink.

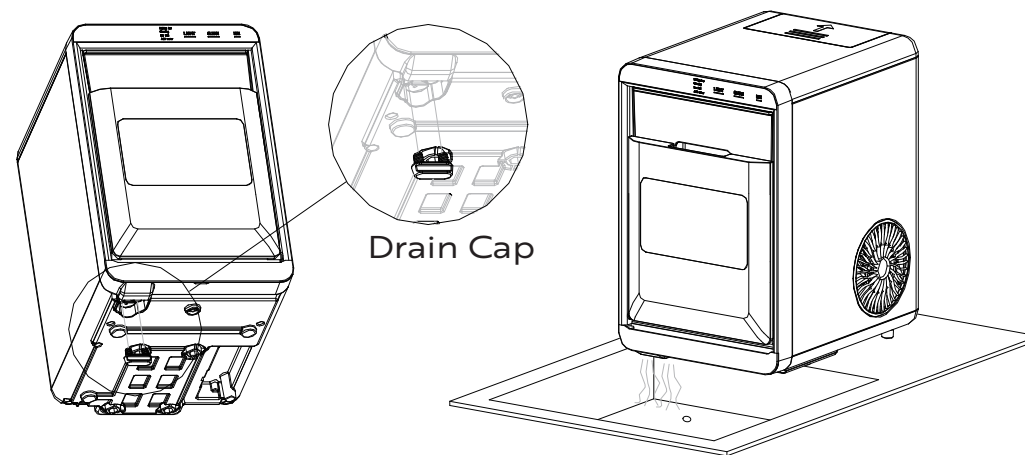

7. Repeat the step 5 to 7 with fresh water for two more cycles to rinse the inside.

8. Replace the drain cap. See the figure below.

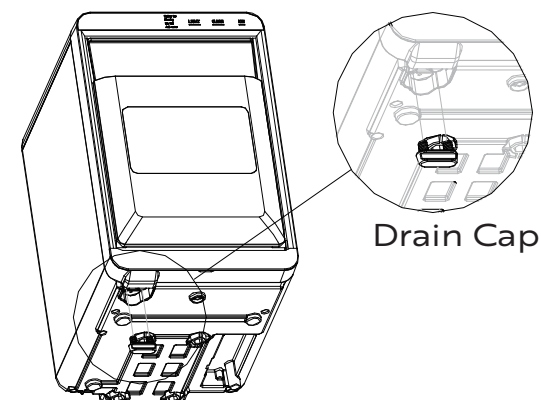

- When completed, fill the unit with fresh water and press the "ICE" button to start ice making process. See the figure below.

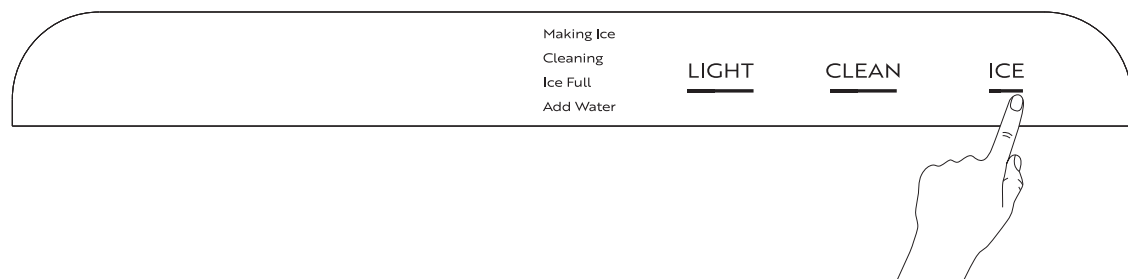

Change water in the water reservoir every 24 hours to ensure a reasonable hygiene level. If the unit isn't to be used, drain all water & dry the water reservoir.

How to obtain the ice-cube

- Before we start making ice, please make sure the water drain cap has been inserted into the appliance; otherwise, it will not work properly.
- Press the "ICE" button; the "Making Ice" indicator will be on; it will begin to work; press this button again; it will stop making ice.
TIPS: For the first time, or if the appliance has not been used for a long time, it is recommended to clean this appliance before you start to make ice.
- While the ice-maker is on, verify water level periodically. If water pump can't pump out water, the ice maker will stop automatically, and the "Add Water" indicator will on. Need to pour water into the water reservoir.
- You can enjoy your ice cubs when the control panel show "Ice full".

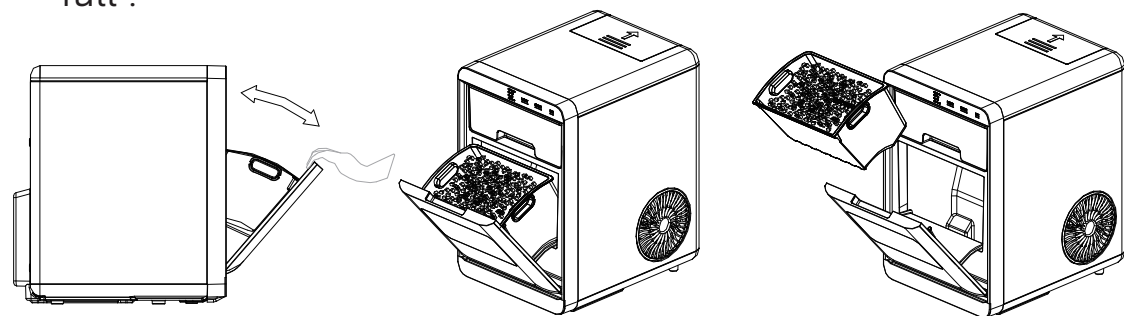

Tips

- When there is water in the water tank and the Add water indicator is on, please push the top water tank into the unit in place.
- When the ice maker is not in use for a period of time, please drain the water inside the unit, because bacteria can easily breed in humid environments.
- After using the ice maker continuously for more than one month, please thoroughly clean the entire unit before use. The cleaning steps refer to the System Cleaning/Sanitizing Procedure of this manual.
- Please gently open the flip door, especially when the ice cubs in the basket is full.
- When ice cubs fall into the gap between the flip door and the front panel accidentally, causing the door to fail to close, please remove the ice cubs first.
- When putting the basket back into the unit, please ensure that it is accurately placed in the limit slot.
- If the basket falls into the internal water tank of the unit due to not being placed in the limit slot, please first remove the water tank at the top of the basket, then you can take out the basket with your bare hands.



Problem	Possible Cause	Solution
"Add Water" indicator lights up	There is no water in the water tank.(Lack of Water)	Stop the ice maker, fill water, and press "ICE" button again to restart the unit.
	Water tank is not in place.	Push the water tank forward till it in position, and press "ICE" button again to restart the unit.
"ICE FULL" indicator lights up or flash	There is too much ice.	Suggest you to obtain the ice-cube.
	No ice cube inside.	Remove the probable obstacle inside or clean the inside wall of the ice storage
"Making Ice" indicator lights flash	The system is under repair	It will automatically resume work. When this problem occurs frequently, please clean the machine carefully.
"Ice" indicator lights and "Making Ice" indicator flash	Ambient temperature or water temperature in inner tank is too high.	Please run the ice maker below 90 Fahrenheit degree ambient and pour colder water into tank.
	Refrigerant liquid leakage.	Press the ICE button twice, restart ice making program, if this problem show up again, verify by a qualified technician.
	Cover motor is broken	
	Pipe in the cooling system is blocked.	
Making Ice too slowly	Hot Air outlet has been blocked by something.	Hot Air outlet must be guaranteed to have more than 15cm of ventilation distance.
	Water temperature in inner tank is too high.	Water temperature requirement between 7°C-32°C.
	Refrigeration system malfunctions.	Verify by a qualified technician.
Water leakage	Drain plug not in place	Put the drain plug in place.
	Pipe Joint in the appliance may Loose	Verify by a qualified technician.
	The seal has reached service life	Verify by a qualified technician.



Model	VH1575
Protection Type	I
Power	115V/60Hz
Ice Making Current	2.7A
Refrigerant	R600a , 0.74Oz // 21g
Vesicant	C ₅ H ₁₀
Net Weight	11Kg
Dimension	240x345x376mm

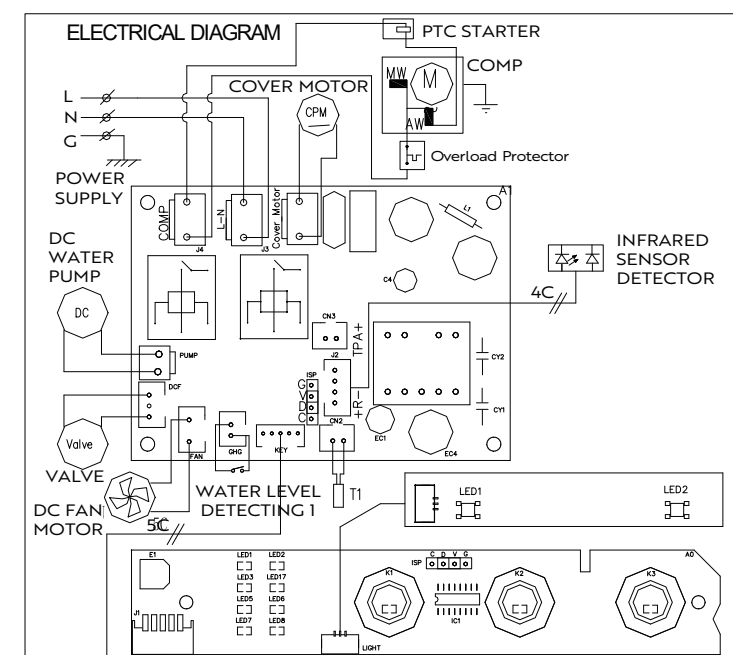



The VIVOHOME warranty program is our commitment to you. We are committed to providing you with a high-quality product that meets your needs and expectations. To demonstrate our confidence in the durability and performance of our products, we offer the following warranty.

WARRANTY COVERAGE

This warranty program applies to any orders, purchases, receipts, or use of any products sold by VIVOHOME and is valid for a period of 1 year from the date of purchase. However, please note that this warranty period is only valid for the original order. If you receive a replacement order during the warranty period, it will not include a separate warranty period.

WARRANTY EXCLUSIONS

This warranty does not cover damage resulting from misuse, accident, unauthorized modification, or any other circumstances not directly related to the manufacturing and design of the product, including but not limited to:

- Parts lost during use.
- Normal wear and tear of products or parts.
- Incorrect installation (such as using the wrong voltage) or assembly.
- Exceeding the bearing capacity of the product.
- Use under extremely harsh conditions.



- Improper cleaning or maintenance.
- Damage caused by any reason other than the intended use of the product.
- Indirect loss or damage caused by the product.

HOW TO MAKE A WARRANTY CLAIM

If you find any defects that affect the use of the product or if the product stops working and cannot be repaired during the warranty period, please contact our customer service team at our email or via Amazon & app's direct messaging service as soon as possible. Provide the following information to expedite the process:

- Order number
- Images and/or videos illustrating the issue
- A detailed description of the problem

VIVOHOME will provide technical support, replacement, refund, or other solutions based on the nature of the issue. If you wish to return the original package for any reason, please contact us for confirmation before proceeding. You can expect to receive a response within 48 hours.

Thank you for choosing VIVOHOME. We are committed to ensuring the quality and satisfaction of your purchase. If you have any questions or need assistance, please do not hesitate to contact our customer service team.