

Installation instruction

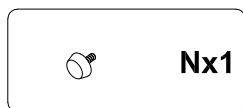

STEP 1

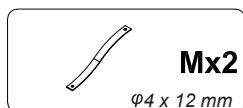
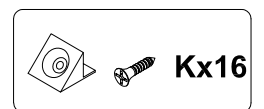
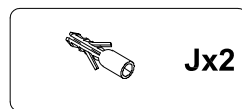
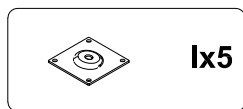
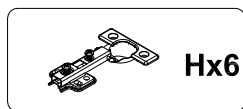
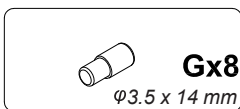
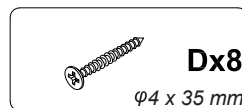
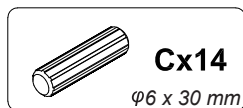
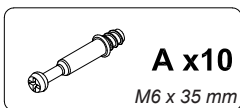
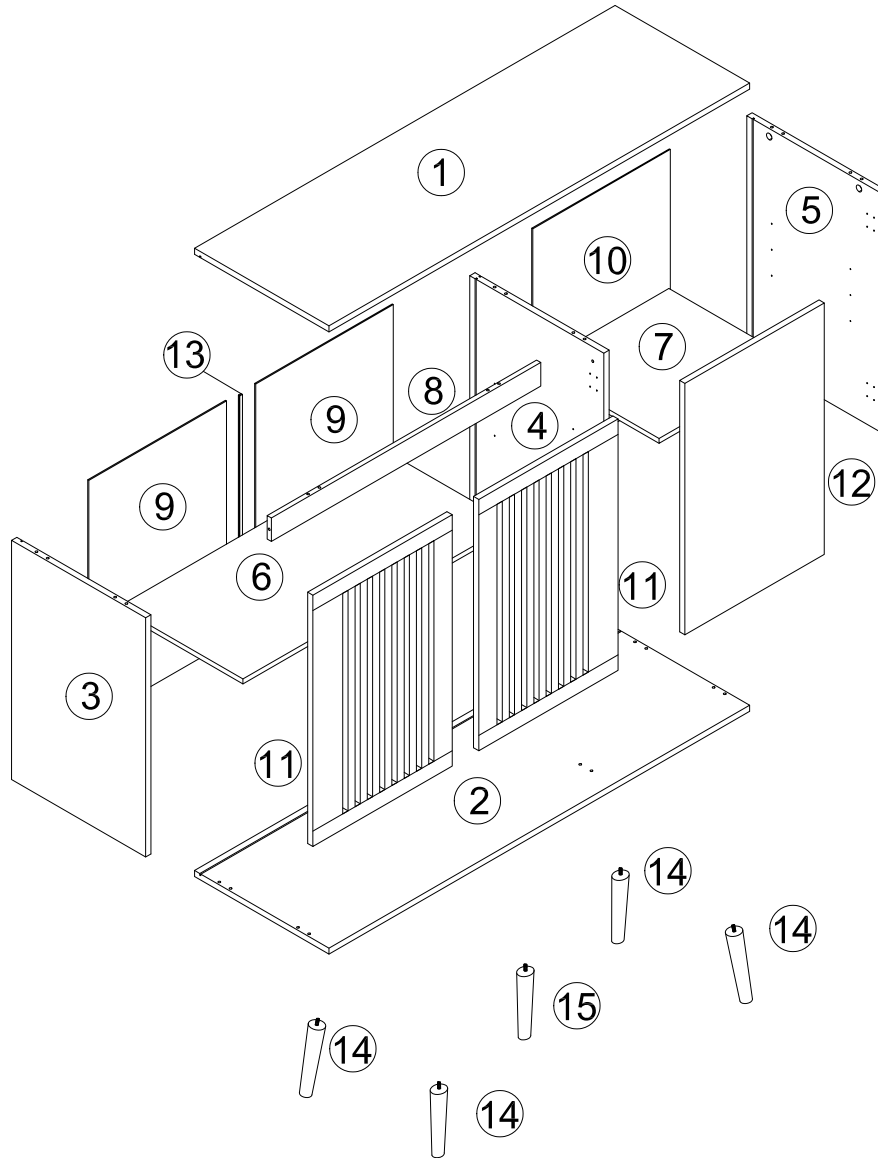
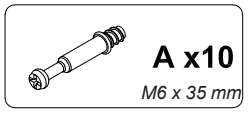
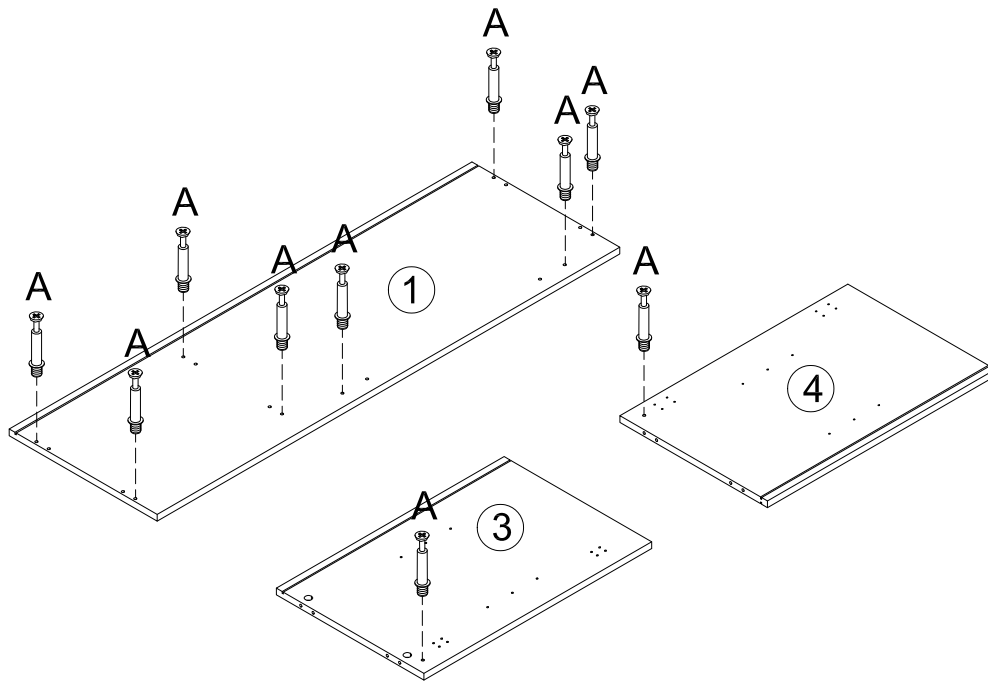
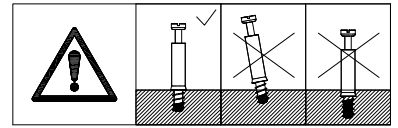

STEP 2

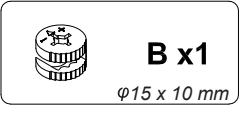
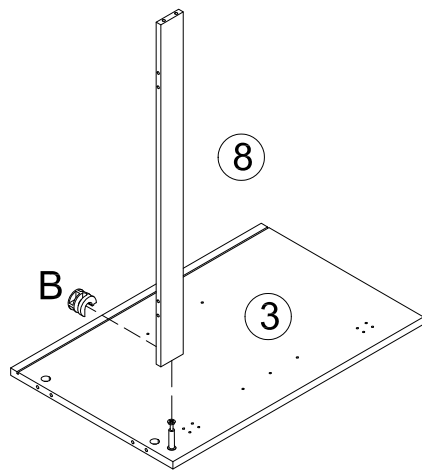
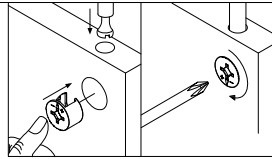

STEP 3

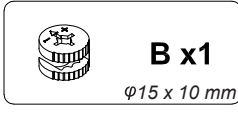
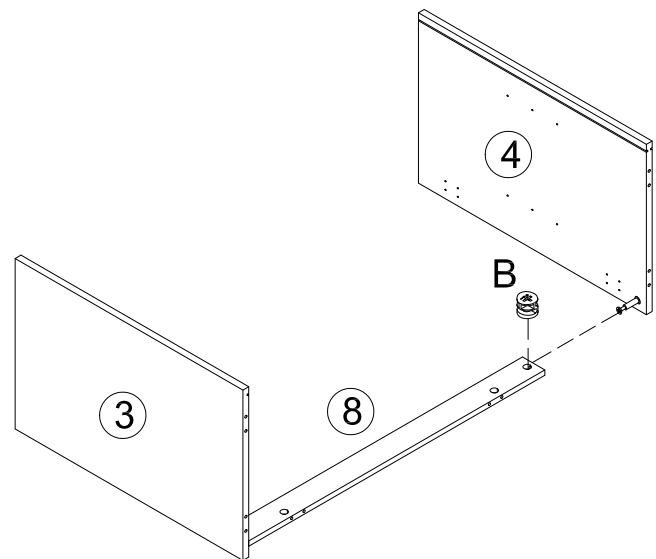
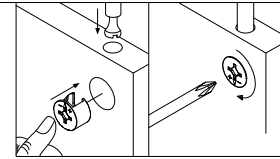

STEP 4

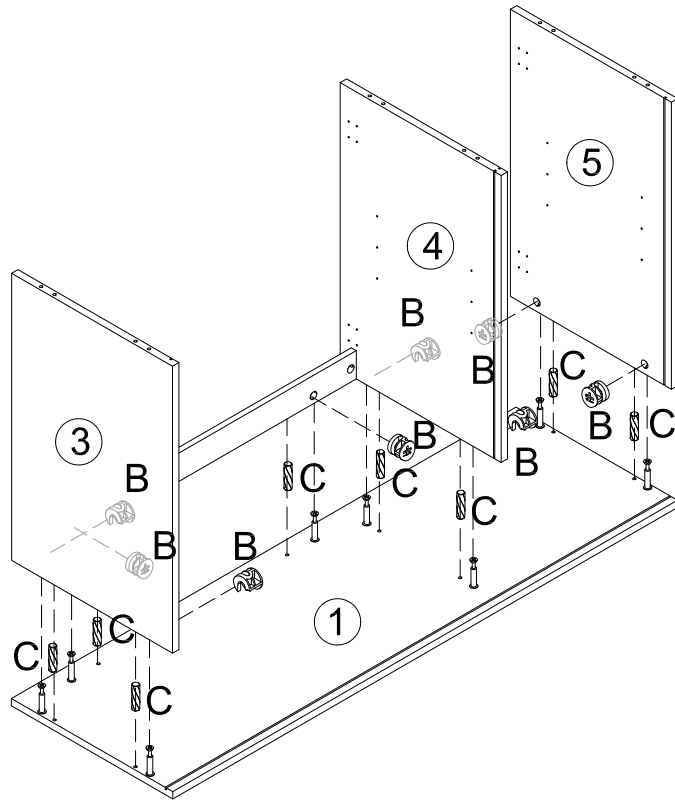

B x8
 $\varnothing 15 \times 10 \text{ mm}$

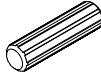

Cx8
 $\varnothing 6 \times 30 \text{ mm}$

STEP 5

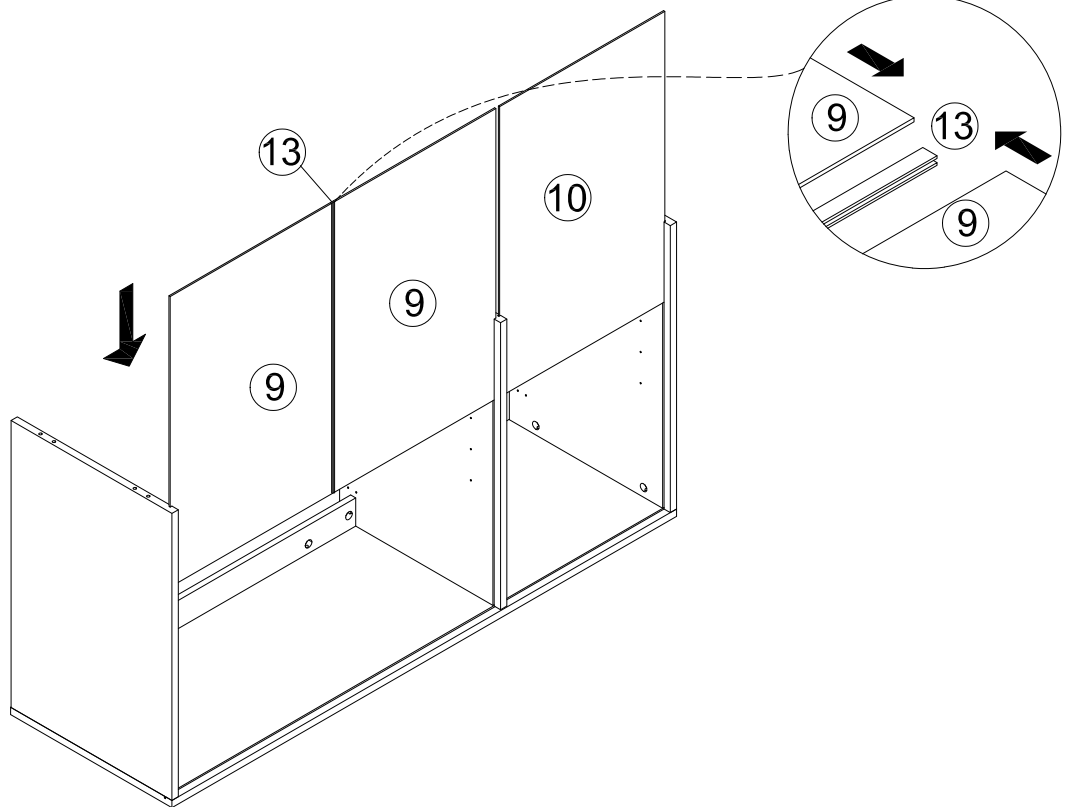

STEP 6

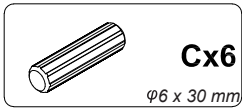
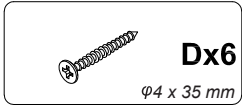
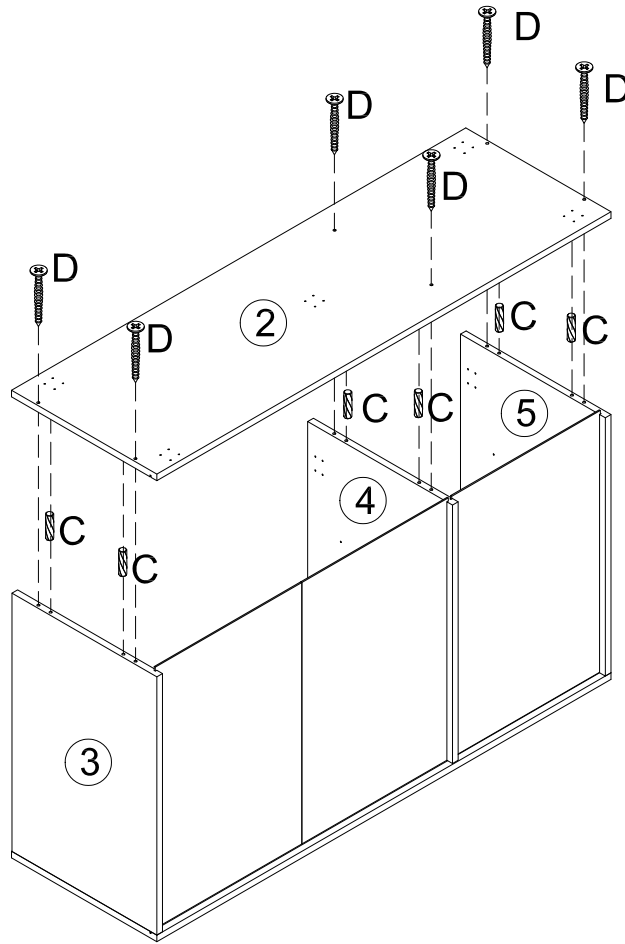

STEP 7

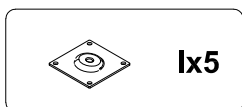
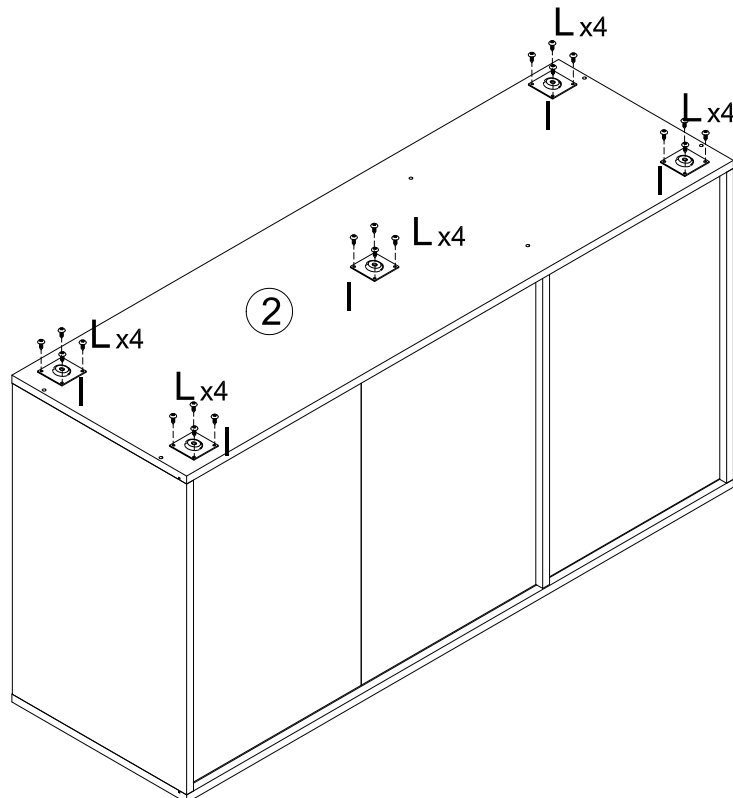

STEP 8

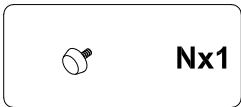
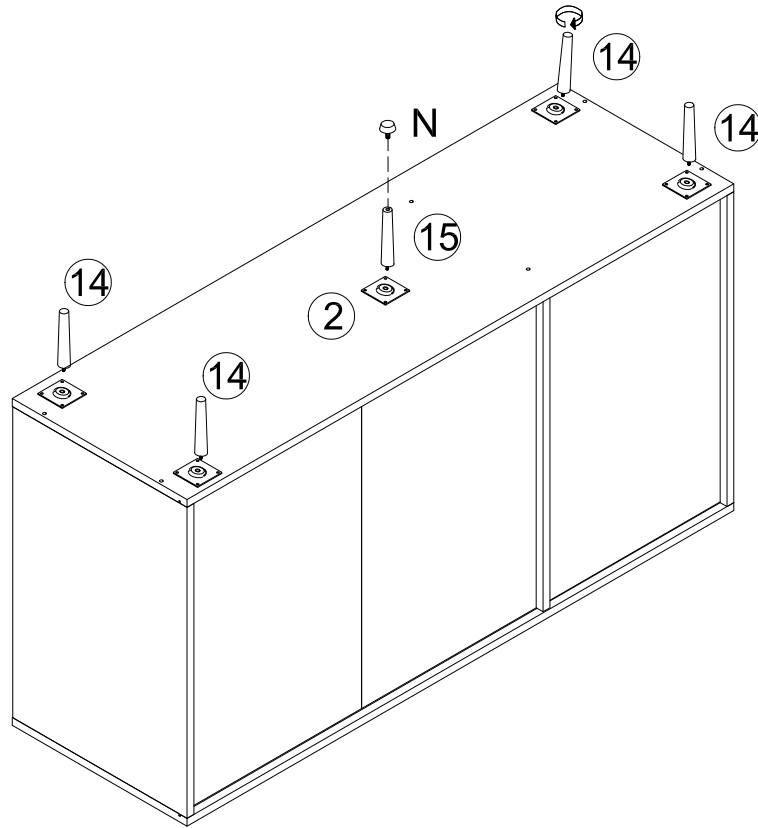

STEP 9

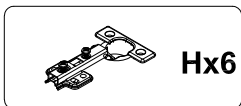
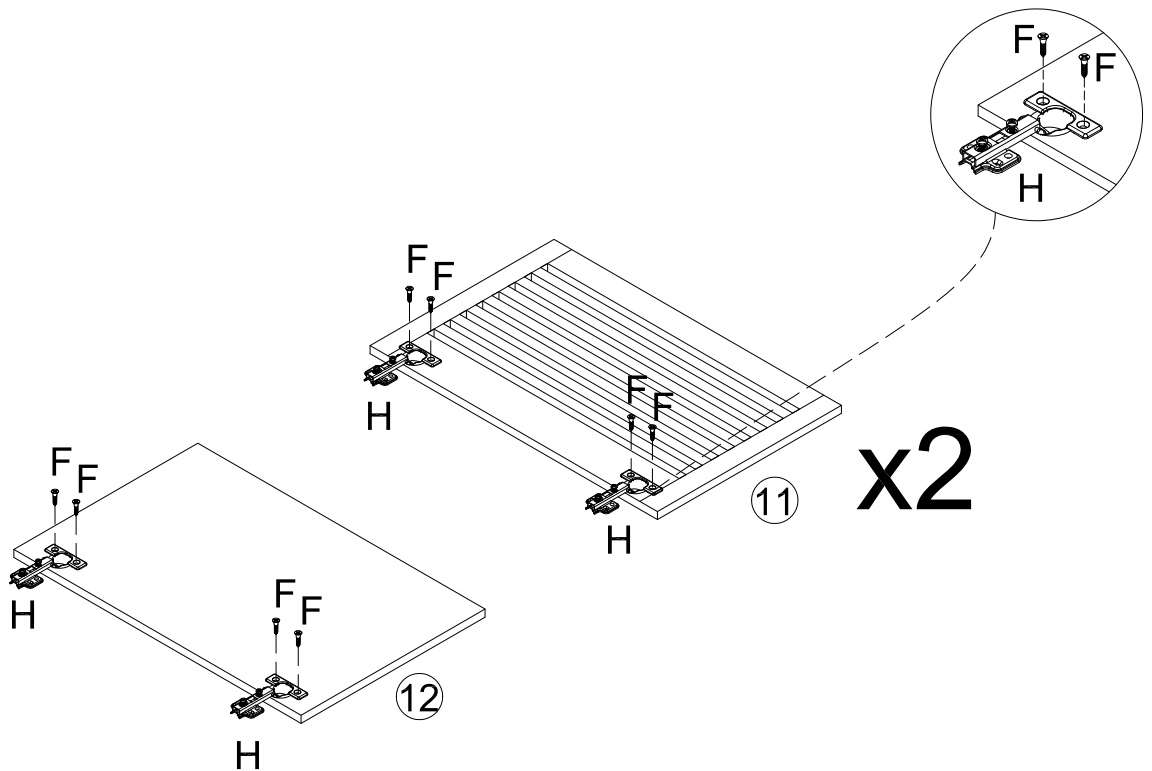

STEP 10

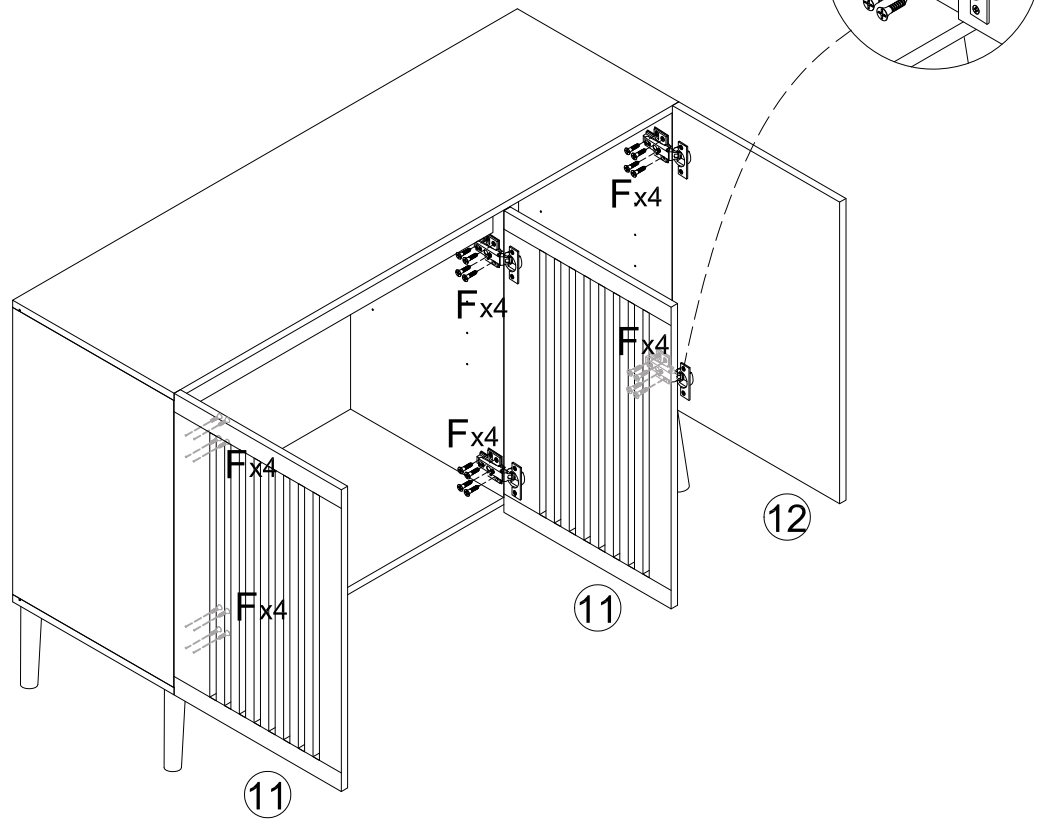
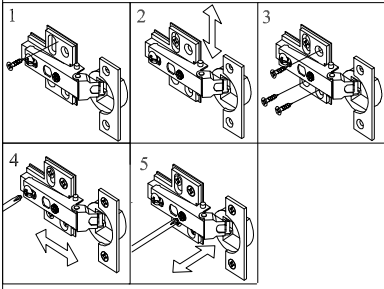

Fx24
 $\varnothing 3.5 \times 14 \text{ mm}$

STEP 11

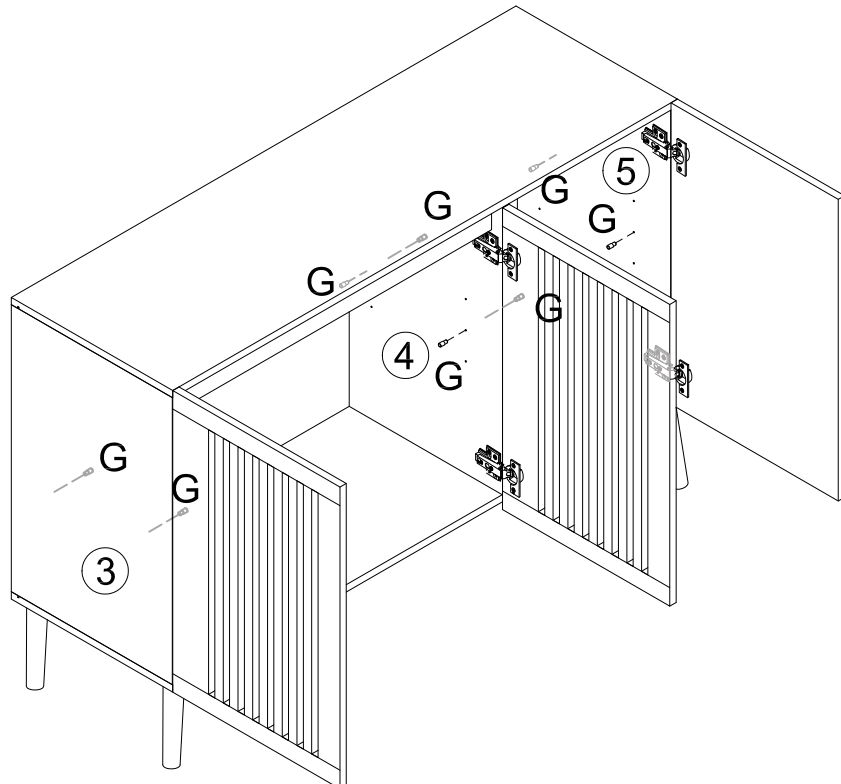

Gx8

STEP 12

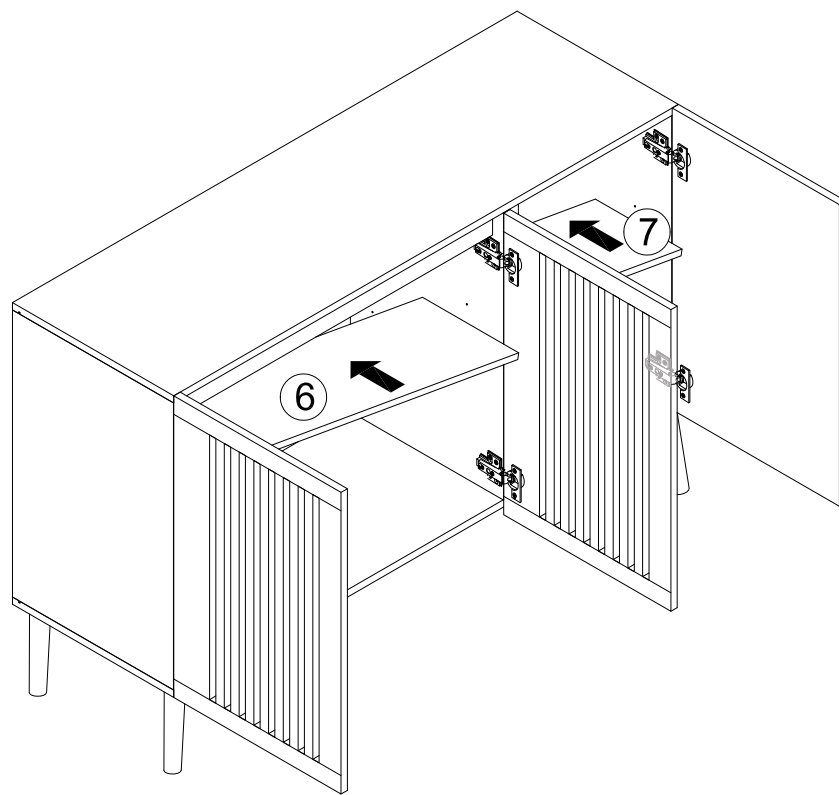

STEP 13

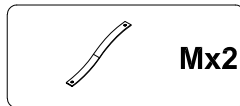
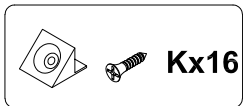
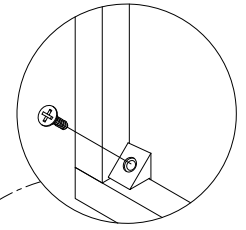
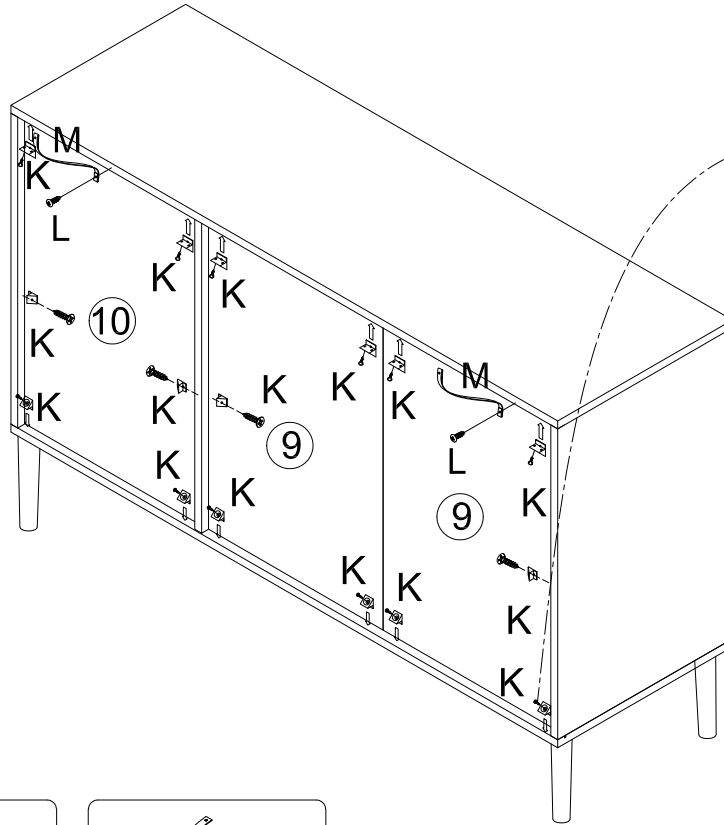
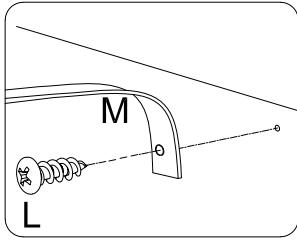

STEP 14

