

ASSEMBLY INSTRUCTIONS

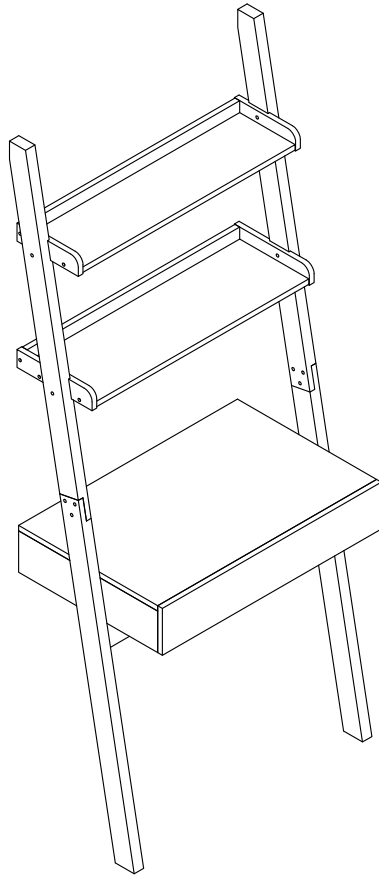

Ladder Desk

ASSEMBLY INSTRUCTIONS

ASSEMBLY TIPS:

1. Remove hardware from box and sort by size.
2. Please check to see that all hardware and parts are present prior to start of assembly.
3. Please follow attached instructions in the same sequence as numbered to assure fast & easy assembly.

Warning !!

1. Don't attempt to repair or modify parts that are broken or defective. Please contact the store immediately.
2. This product is for home use only and not intended for commercial establishment.



ASSEMBLY TIME

30 MINUTES



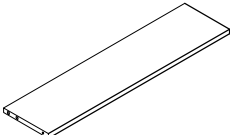
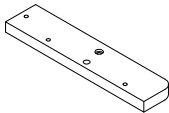
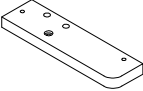
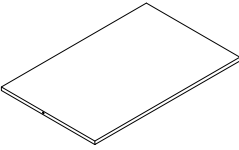
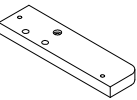
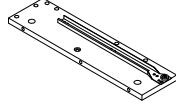
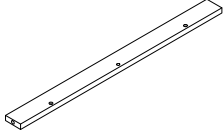
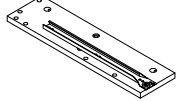
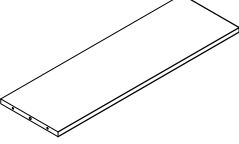
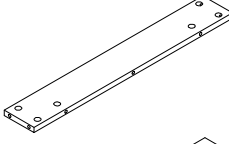
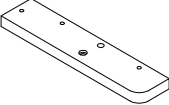
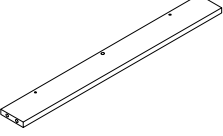



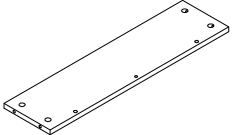
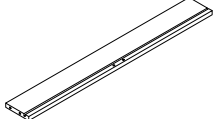
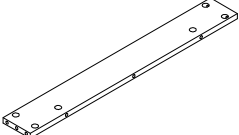
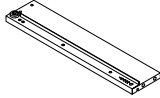
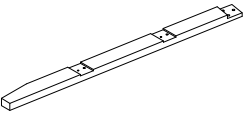
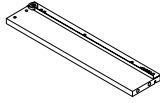
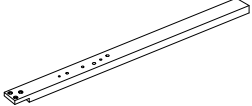
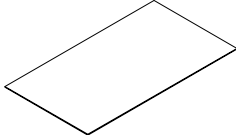
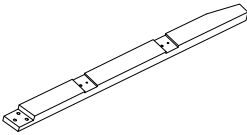
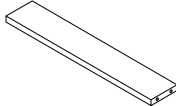
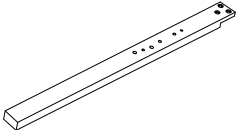
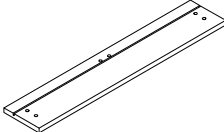



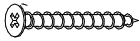

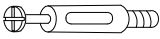

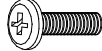

PARTS IDENTIFICATION

(A) UPPER SHELF		1 PC	(G) LOWER RIGHT CROSSBAR		1 PC
(B) UPPER LEFT CROSSBAR		1 PC	(H) TOP		1 PC
(C) UPPER RIGHT CROSSBAR		1 PC	(I) LEFT SIDE PANEL		1 PC
(D) BACK CROSSBAR		2 PCS	(J) RIGHT SIDE PANEL		1 PC
(E) LOWER SHELF		1 PC	(K) BACK PANEL		1 PC
(F) LOWER LEFT CROSSBAR		1 PC	(L) REAR BOTTOM CROSSBAR		1 PC

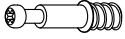
PARTS IDENTIFICATION

(M) FRONT BOTTOM CROSSBAR		1 PC	(S) DRAWER BACK PANEL		1 PC
(N) MEDIUM BOTTOM CROSSBAR		1 PC	(T) DRAWER LEFT SIDE PANEL		1 PC
(O) LEFT UPPER POST		1 PC	(U) DRAWER RIGHT SIDE PANEL		1 PC
(P) LEFT LOWER POST		1 PC	(V) DRAWER BOTTOM PANEL		1 PC
(Q) RIGHT UPPER POST		1 PC	(A1) DRAWER BOTTOM SUPPORT		1 PC
(R) RIGHT LOWER POST		1 PC	(A2) DRAWER FRONT PANEL		1 PC

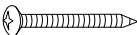
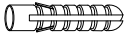
HARDWARE IDENTIFICATION

1	LARGE SCREW	ø4x30mm		26 pcs
2	SHORT DOWEL	Ø8x25mm		11 pcs
3	SMALL STICKER	ø13mm		18 pcs
4	LARGE CAMBOLT	L29mm		24 pcs
5	LARGE CAMLOCK	ø15mm		24 pcs
6	INNER THREAD SCREW	M6mm		6 pcs
7	LARGE FLAT HEADED SCREW	M6x20mm		10 pcs
8	LARGE STICKER	ø20mm		18 pcs
9	METAL CONNECTING PIECE	170x24x3mm(BK)		2 pcs
10	SMALL FLAT HEADED SCREW	M6x12mm(BK)		8 pcs
11	ALLEN BOLT	M6x65mm		6 pcs
12	WASHER	ø8xø16x2mm		6 pcs
13	BARREL NUT	M6x11mm		6 pcs
14	SMALL CAMBOLT	L20mm		4 pcs
15	SMALL CAMLOCK	ø12mm		4 pcs
16	LONG DOWEL	ø6x30mm		2 pcs
17	ANTI-TIP HARDWARE			1 pcs
18	SMALL SCREW	ø4x25mm		1 pcs
19	WALL SCREW	ø5x40mm		1 pcs
20	PLASTIC ANCHOR	ø8x40mm		1 pcs
21	ALLEN WRENCH	M4mm		1 pcs
22	BRACKET	12x12x1mm		2 pcs

ASSEMBLY INSTRUCTIONS

STEP 1

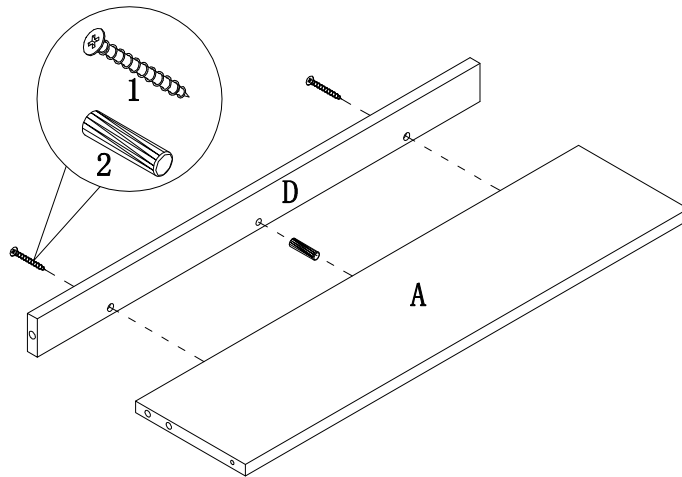

STEP 2

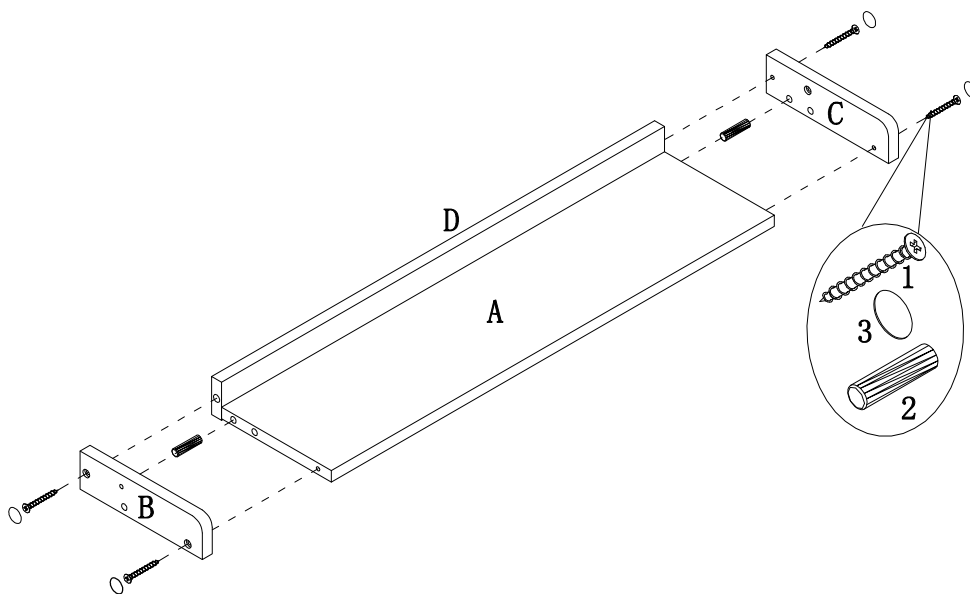

ASSEMBLY INSTRUCTIONS

STEP 3

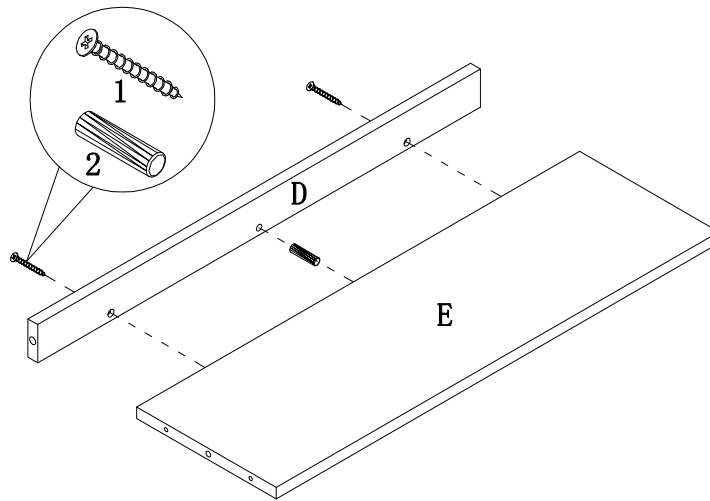

STEP 4

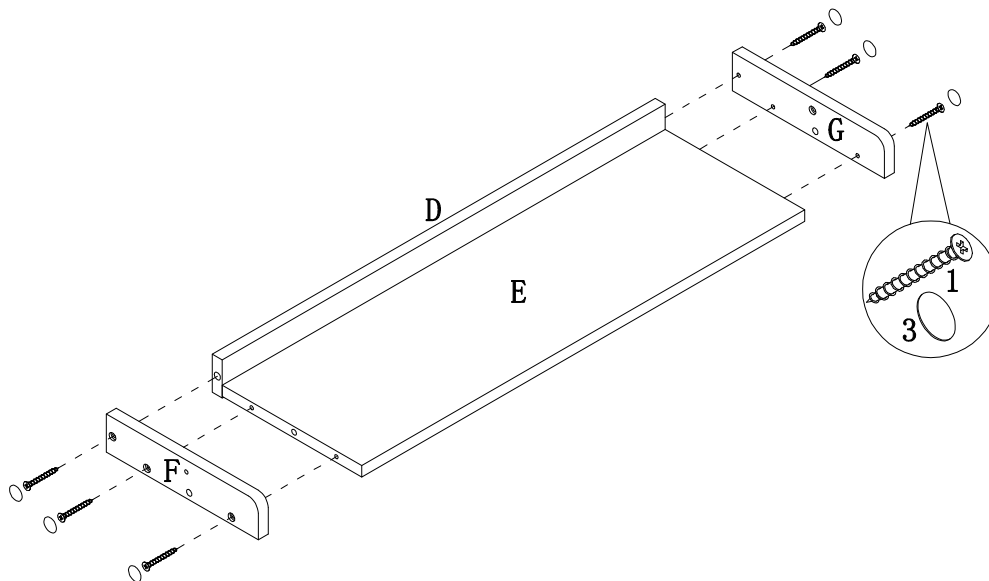

ASSEMBLY INSTRUCTIONS

STEP 5

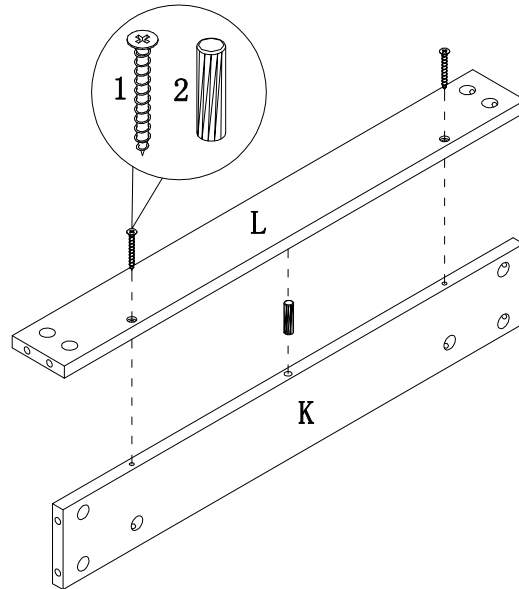

STEP 6

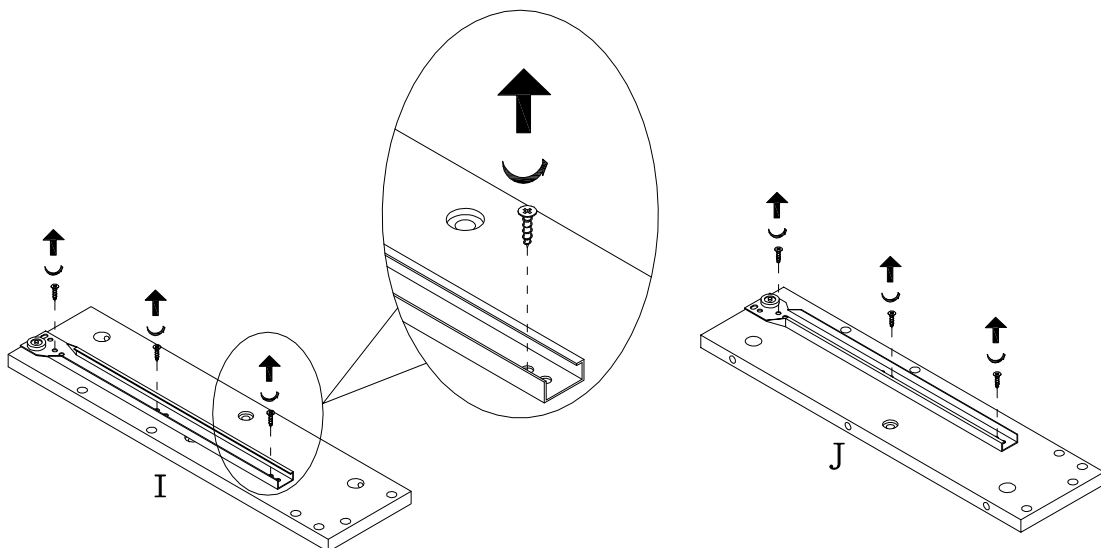

ASSEMBLY INSTRUCTIONS

STEP 7

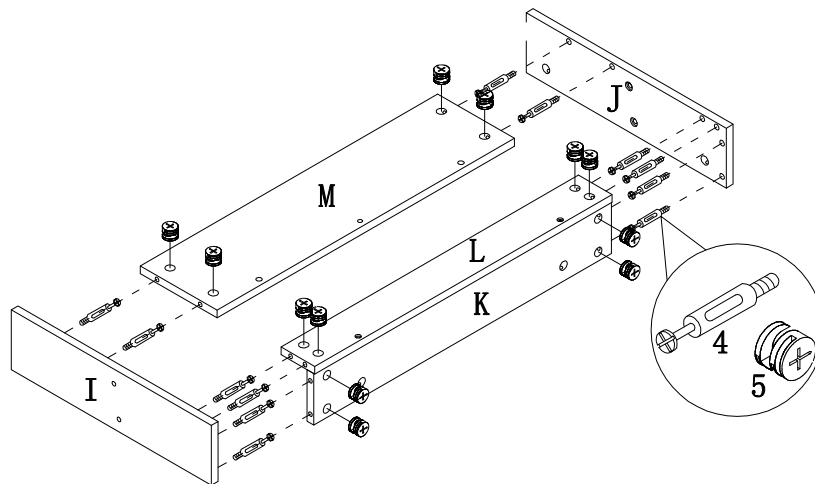

STEP 8

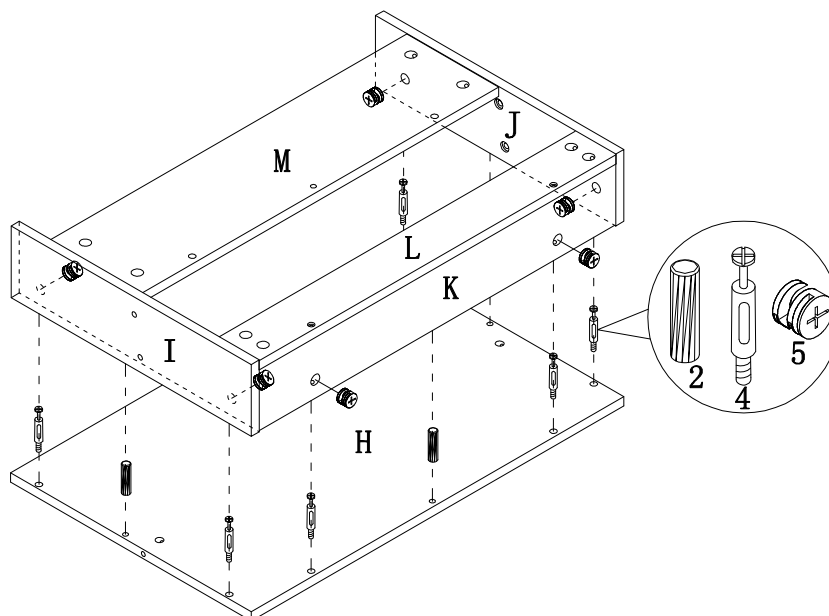

ASSEMBLY INSTRUCTIONS

STEP 9

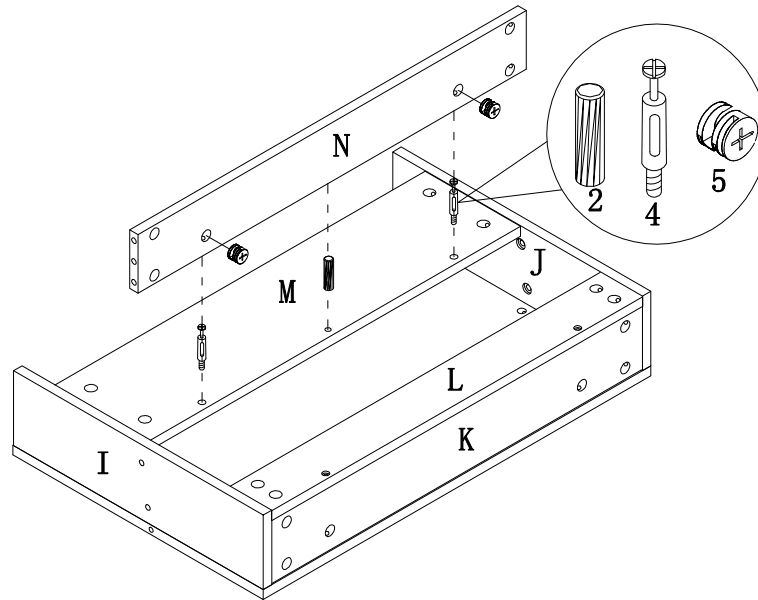

STEP 10

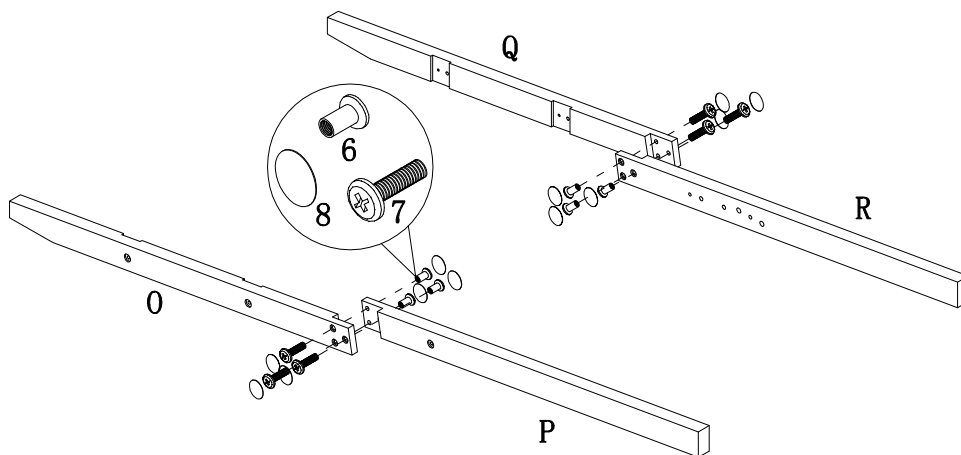

ASSEMBLY INSTRUCTIONS

STEP 11

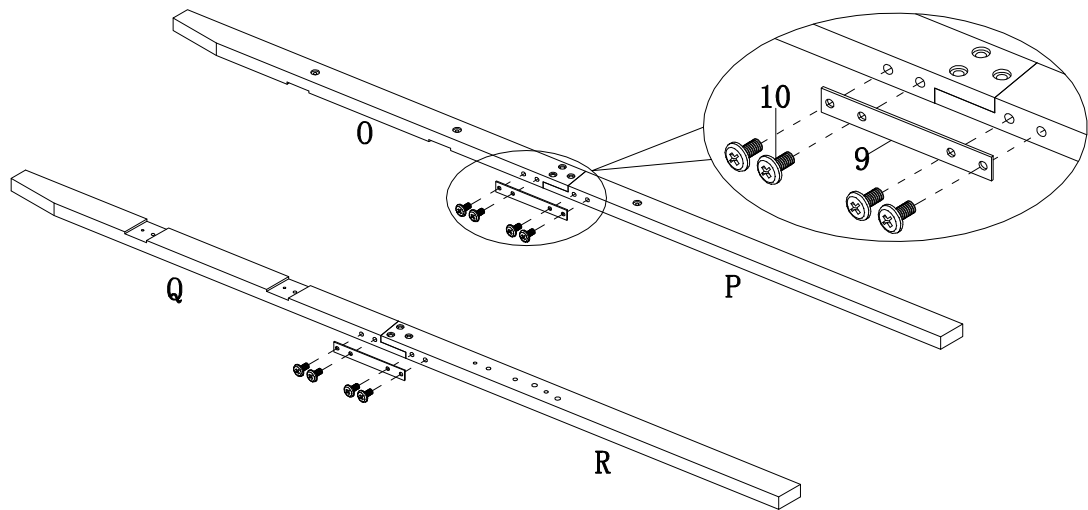

STEP 12

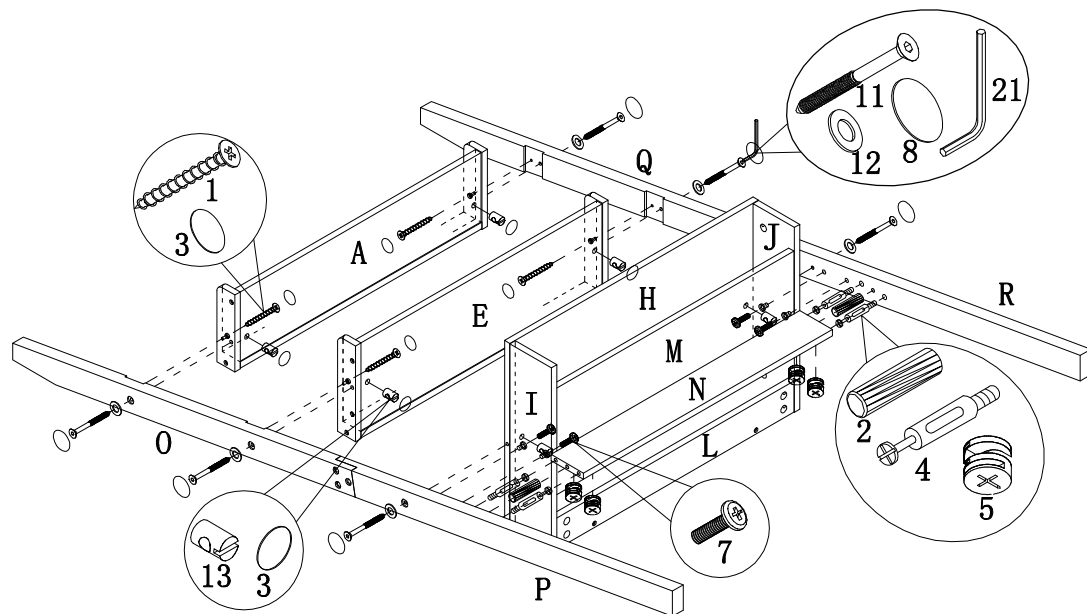

ASSEMBLY INSTRUCTIONS

STEP 13

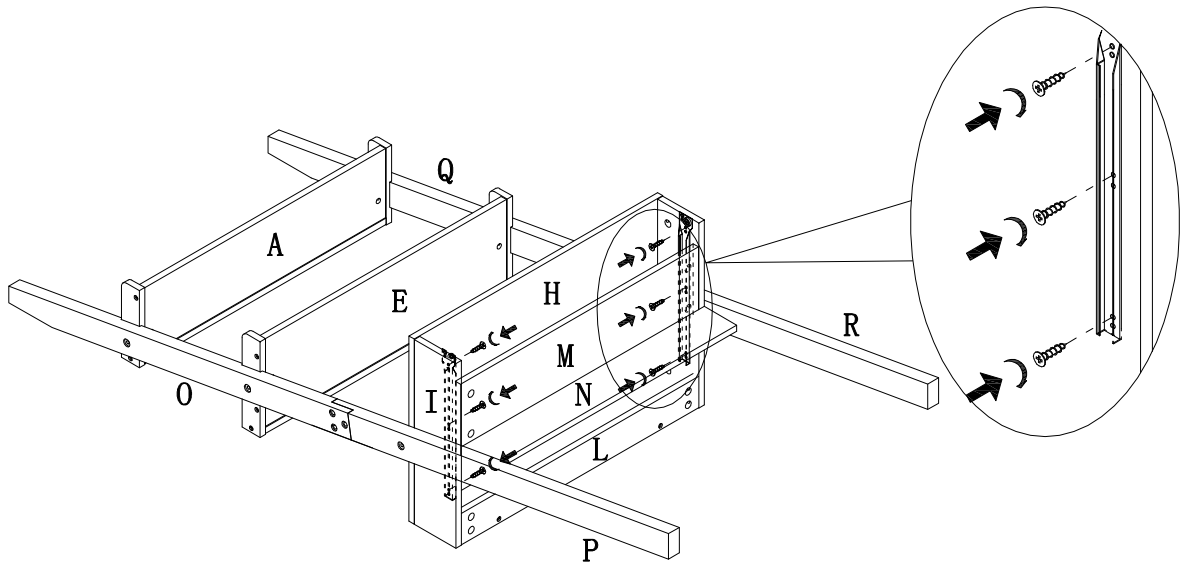

STEP 14

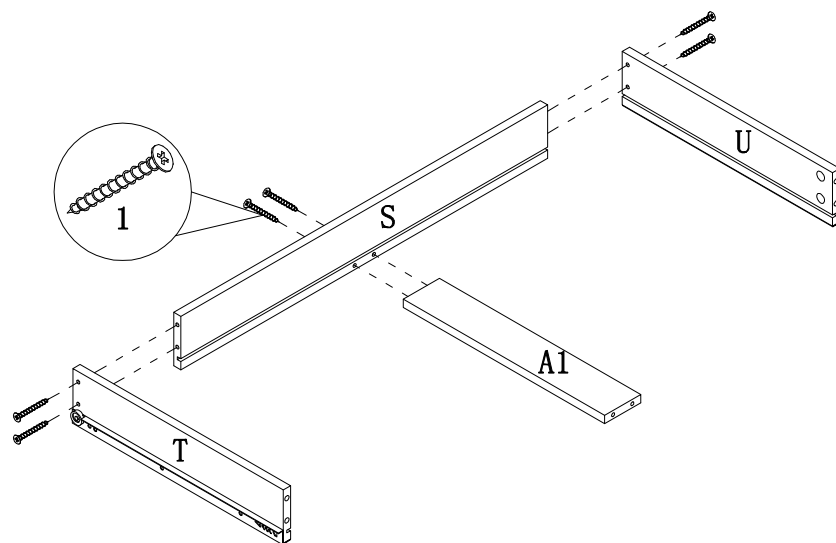

ASSEMBLY INSTRUCTIONS

STEP 15

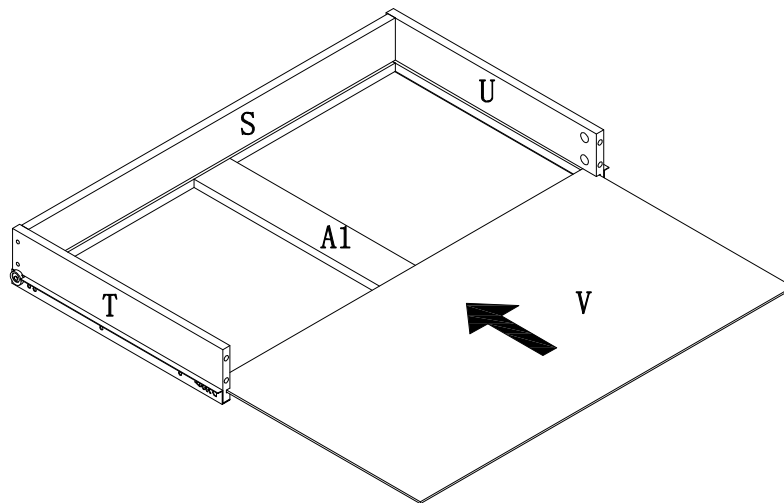

STEP 16

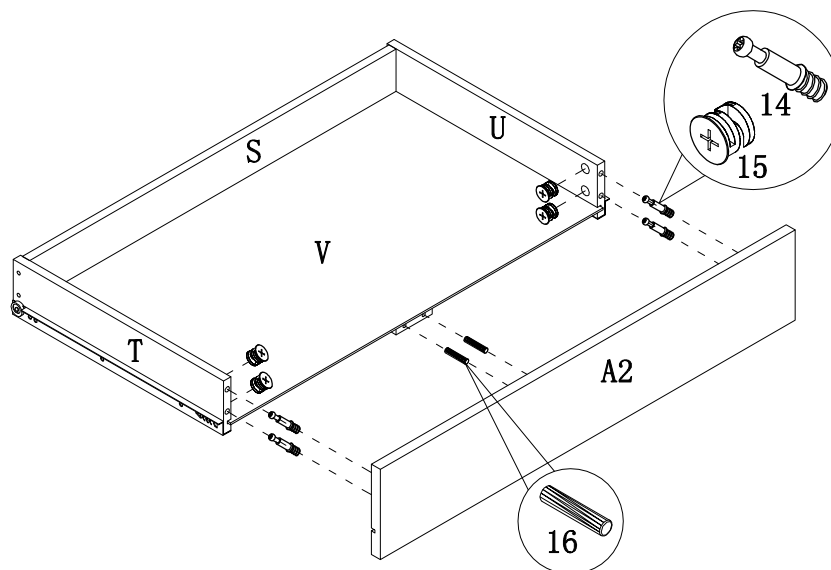

ASSEMBLY INSTRUCTIONS

STEP 17

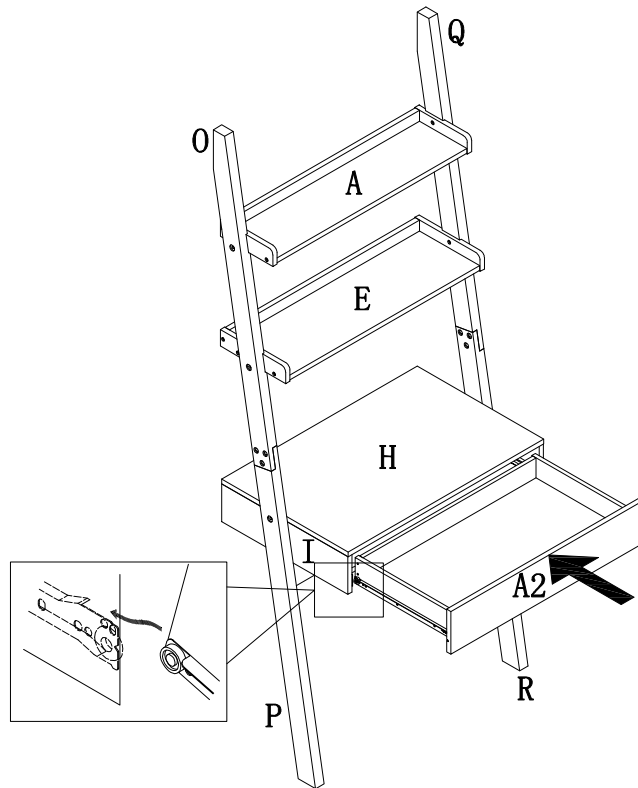

STEP 18

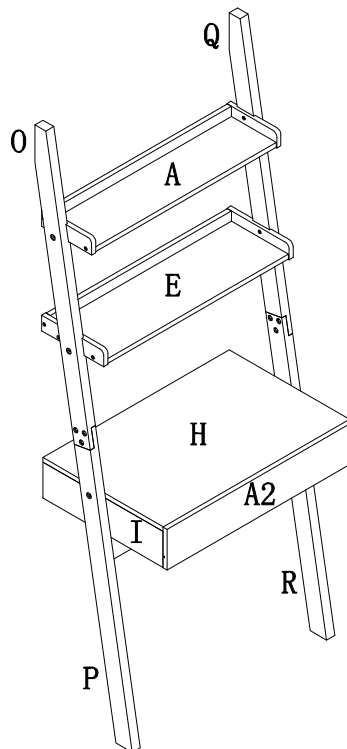

DIMENSION

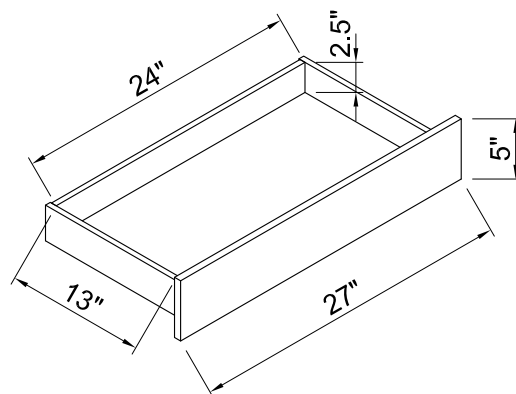
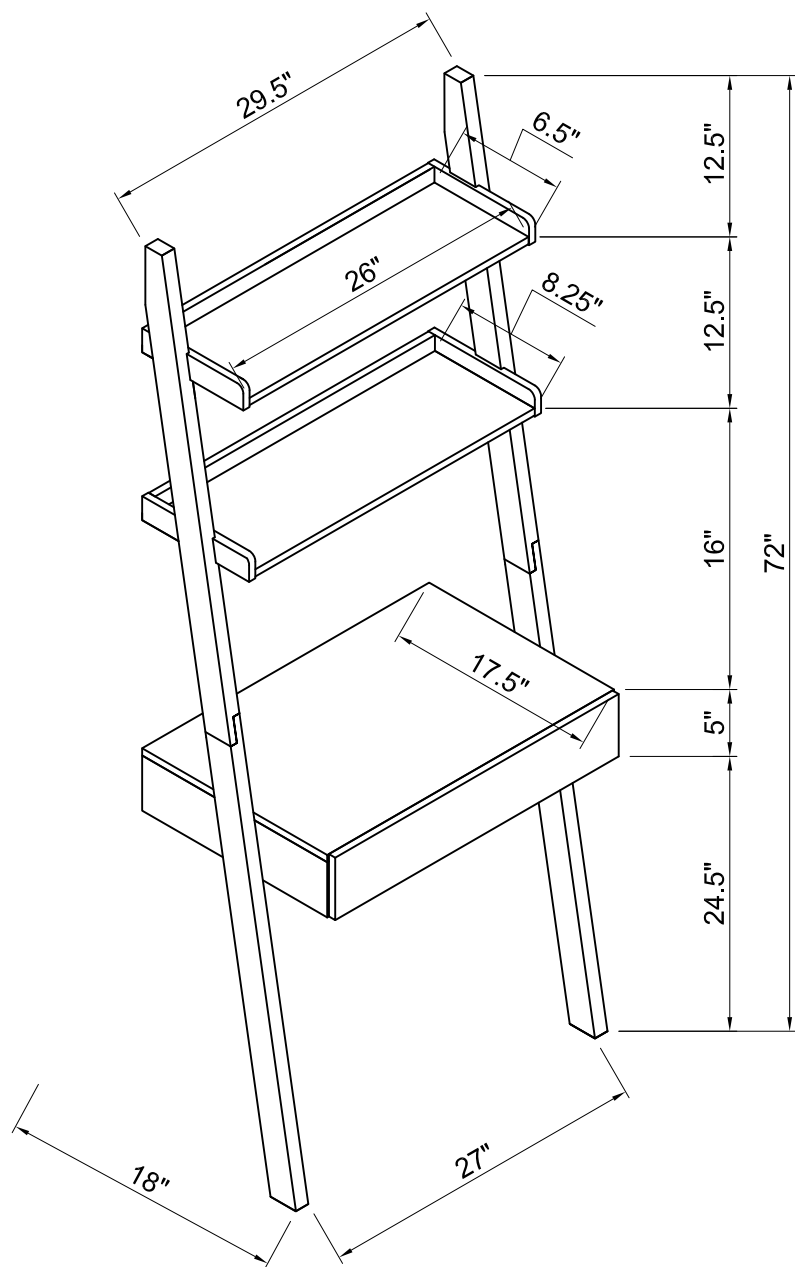

ANTI-TIPPING INSTALLMENT INSTRUCTIONS

FURNITURE TIPPING RESTRAINT

WARNING

Injury may result from tipping furniture.
This restraint may protect against tipping furniture.
Do not allow children to climb on furniture.
This restraint is not a substitute for proper adult supervision.
Failure to detach this restraint before moving the furniture may result in injury and damage.

This tip restraint must be attached to a wall stud using long screw enclosed.

STEP 1

Attach a bracket securely to the back top rail to the furniture using short screw provided, through the smaller hole.

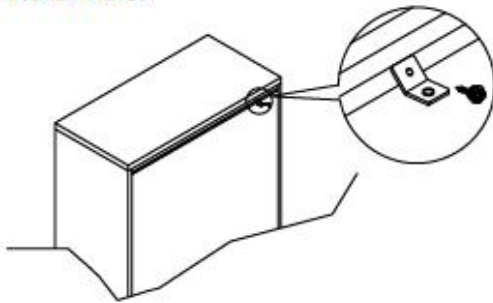

STEP 2

Locate the other bracket on the wall over a wall stud and two inches below the mounting bracket secured to the back of the furniture. Attach the wall stud using the long screw provided, through the smaller hole.

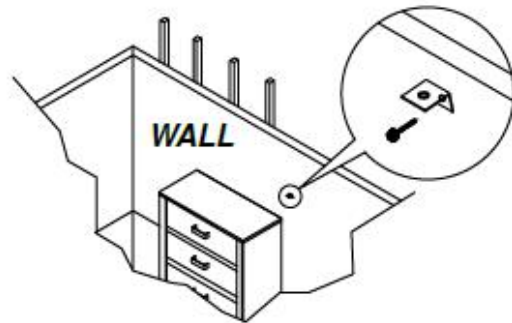

STEP 3

Place the furniture into position so both mounting brackets are vertically in line. Lace the end of the restraint strap through the larger hole in each mounting bracket. Bring both ends together and slide the flat end through the locking and draw it until all slack is removed. Confirm that the strap is securely laced and locked.

