

Parts List For Bed

BED CARTON

- (10) HEADBOARD PANEL
- (11) FOOTBOARD PANEL
- PART HARDWARE BAG FOR BED ATTACHMENT TO FRAME
- (1) 1/4-20 X 2 1/4" COUNTERSUNK ALLEN HEAD SCREW-4
- (2) 1/4-20 X 1" FLAT ALLEN HEAD SCREW-4
- (3) 1/4-20 HEX NUT-4
- (4) 1/4" ID FLAT WASHER-8
- (5) ALLEN WRENCH

- (6) EXTENSION LEG-2
- (7) FINIAL-4
- (8) FOOT CASTING-2
- (9) PLASTIC GLIDES-2

NOTE: PLASTIC GLIDES PRE-INSTALLED-2

HEADBOARD CARTON

- (10) HEADBOARD PANEL
- PART HARDWARE BAG FOR HEADBOARD ATTACHMENT TO FRAME
- (1) 1/4-20 X 2 1/4" COUNTERSUNK ALLEN HEAD SCREW-4
- (3) 1/4-20 HEX NUT-4
- (4) 1/4" ID FLAT WASHER-4
- (5) ALLEN WRENCH

- (6) EXTENSION LEG-2
- (7) FINIAL-2
- (9) PLASTIC GLIDES-2

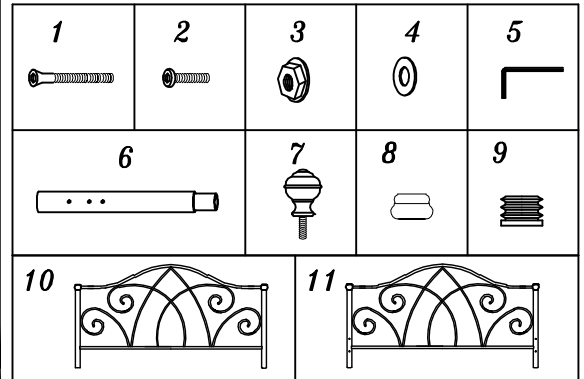

PRODUCT FULLY ASSEMBLED

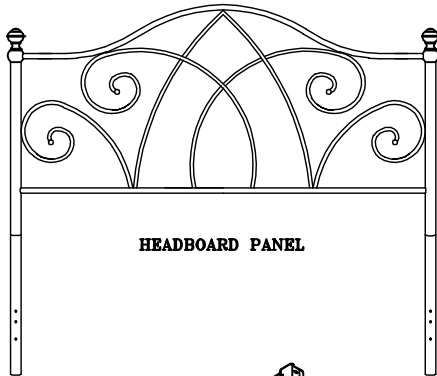

HEADBOARD PANEL

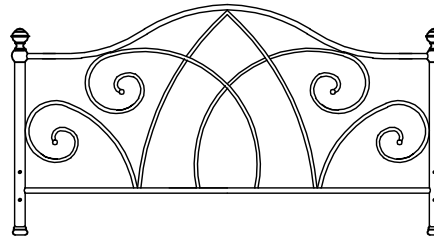

FOOTBOARD PANEL

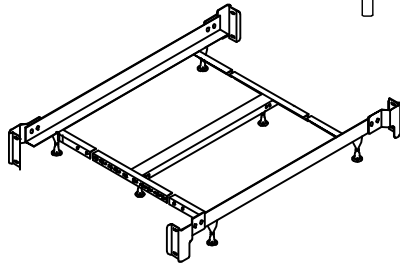

QUEEN - KING BED FRAME FULLY ASSEMBLED
NOTE: SEE INSTRUCTIONS INCLUDED IN FRAME CARTON FOR FRAME ASSEMBLY

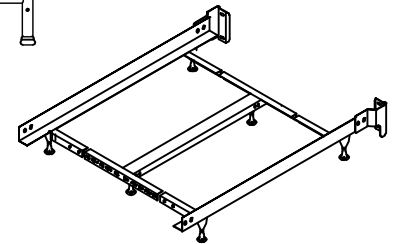

QUEEN - KING HEADBOARD ONLY FRAME FULLY ASSEMBLED
NOTE: SEE INSTRUCTIONS INCLUDED IN FRAME CARTON FOR FRAME ASSEMBLY

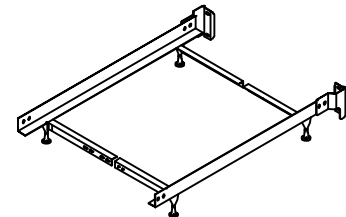

TWIN - FULL HEADBOARD ONLY FRAME FULLY ASSEMBLED
NOTE: SEE INSTRUCTIONS INCLUDED IN FRAME CARTON FOR FRAME ASSEMBLY

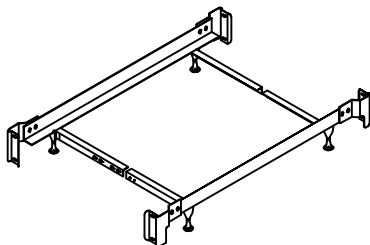

TWIN - FULL BED FRAME FULLY ASSEMBLED
NOTE: SEE INSTRUCTIONS INCLUDED IN FRAME CARTON FOR FRAME ASSEMBLY

FOR ASSISTANCE IN ASSEMBLY ONLY OF THIS PRODUCT. CALL OUR HELP DESK . PLEASE HAVE THE STYLE NUMBER AVAILABLE BEFORE YOU CALL. (STYLE # OR NAME CAN BE FOUND ON PACKING CARTON OR SALES RECEIPT.) OUR PRODUCT IS INSPECTED TO ENSURE IT IS IN GOOD CONDITION. IF YOUR FURNITURE APPEARS TO HAVE BEEN DAMAGED IN SHIPMENT OR YOU ARE IN NEED OF REPLACEMENT PARTS PLEASE CONTACT THE DEALER FROM WHOM YOU PURCHASED THE PRODUCT.

Instruction Sheet

SAVE ALL PACKAGING MATERIALS UNTIL PRODUCT IS FULLY ASSEMBLED. HARDWARE AND SMALL PIECES MAY NOT BE SEEN AND COULD BE ACCIDENTALLY DISCARDED WITH PACKAGING MATERIALS.

FIGURE 1

HEADBOARD PANEL

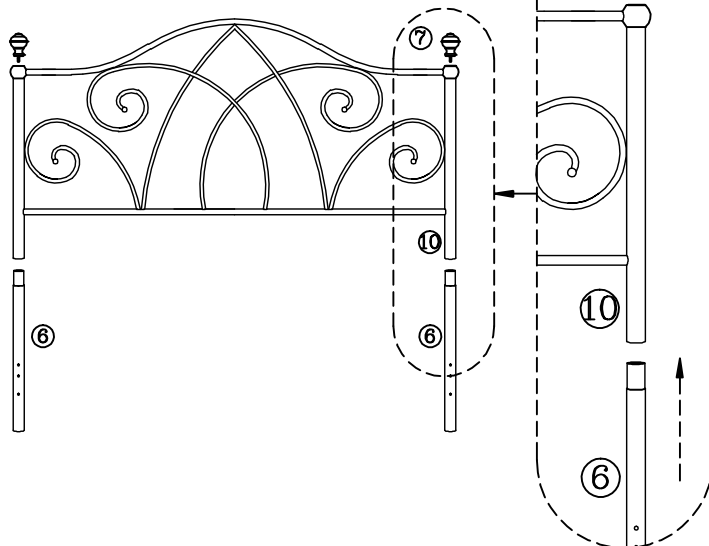

FIGURE 2

FOOTBOARD PANEL

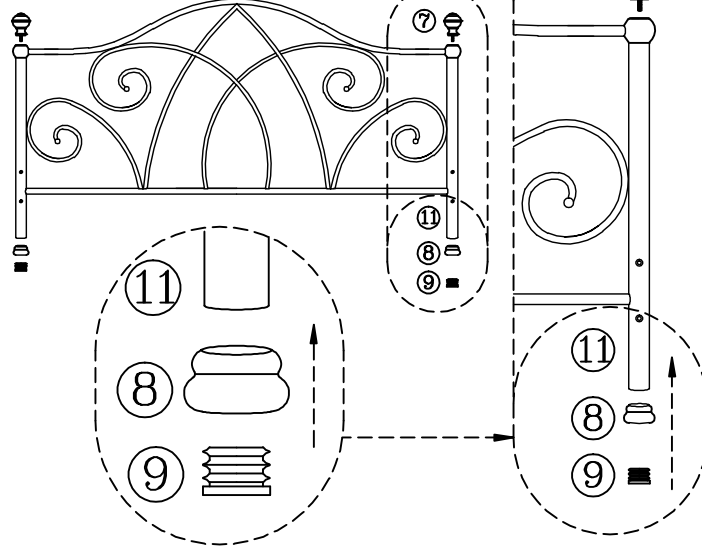
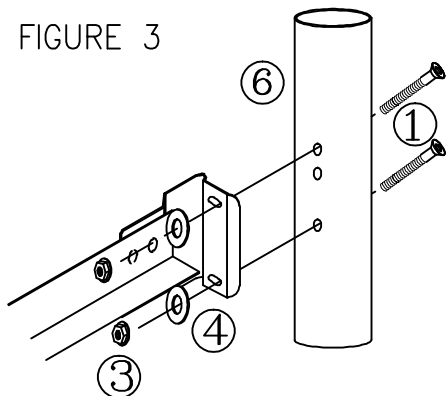

FIGURE 3



Step 1 Headboard Assembly

- Align top reduction of extension legs (6) with bottom of headboard panel (10) posts. (SEE FIGURE 1) Make sure the 3 holes on extension legs are perpendicular to headboard panel.
- Now carefully insert extension legs (6) into bottom of headboard (10) posts.
- Screw in finials (7) on top of headboard Panel (10). (SEE FIGURE 1)

Step 2 Footboard Assembly

- Insert foot casting (8) into footboard panel post (11). (SEE FIGURE 2)
- Secure foot casting (8) with plastic glide (9).
- Screw in finials (7) on top of footboard Panel (11). (SEE FIGURE 2)

Step 3 Headboard Frame Assembly

- Place headboard and frame in desired location in room.
- Place 2 screws (1) through holes located in extension leg (6). (SEE FIGURE 3)
- Align bed frame bracket over screws.
- Place a flat metal washer (4) over screws first and then a hex nut (3) on each screw. Hand tighten, DO NOT TIGHTEN screws all the way.
- Repeat on other side of headboard.
- Tighten all screws securely using the Allen wrench (5).

FIGURE 4

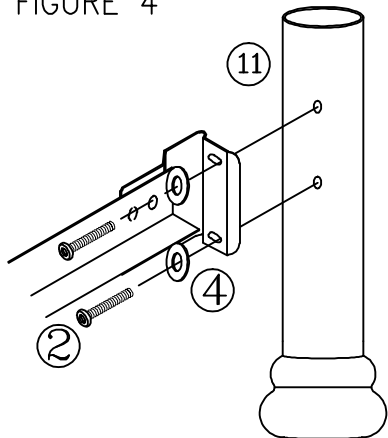

Step 3 Footboard Frame Assembly

- Position footboard panel (11) and align holes in the post with holes in the frame bracket. (SEE FIGURE 4)
- Place flat metal washer (4) on each screw (2). Insert through bracket and into footboard post. Hand tighten, DO NOT TIGHTEN screws all the way.
- Repeat on other side of footboard panel.
- Tighten all screws securely using the Allen wrench (5).