



Made In China

WARNING

Serious or fatal injury may occur from unexpected assembly or use.

1. During the assembly process, keep all parts away from babies or children.
2. Always securely fix this product to the wall. Make sure the wall area to be drilled is free from hidden electrical wires, water and gas pipes.
3. Use of tip-over restraints may only reduce, but not eliminate the risk of tip-over.
4. Unless specially designed to accommodate, do not set heavy objects on top of this product.
5. Place the heaviest items on the lowest shelf.
6. Never allow children to climb or bang on drawers, doors or shelves.

 WARNING	
	<p>Children have died from furniture tipover. To reduce the risk of furniture tipover:</p> <ul style="list-style-type: none">● ALWAYS install tipover restraint provided.● NEVER put a TV on this product.● NEVER allow children to stand, climb or hang on drawers, doors, or shelves.● NEVER open more than one drawer at a time.● Place heaviest items in the lowest drawers.
	



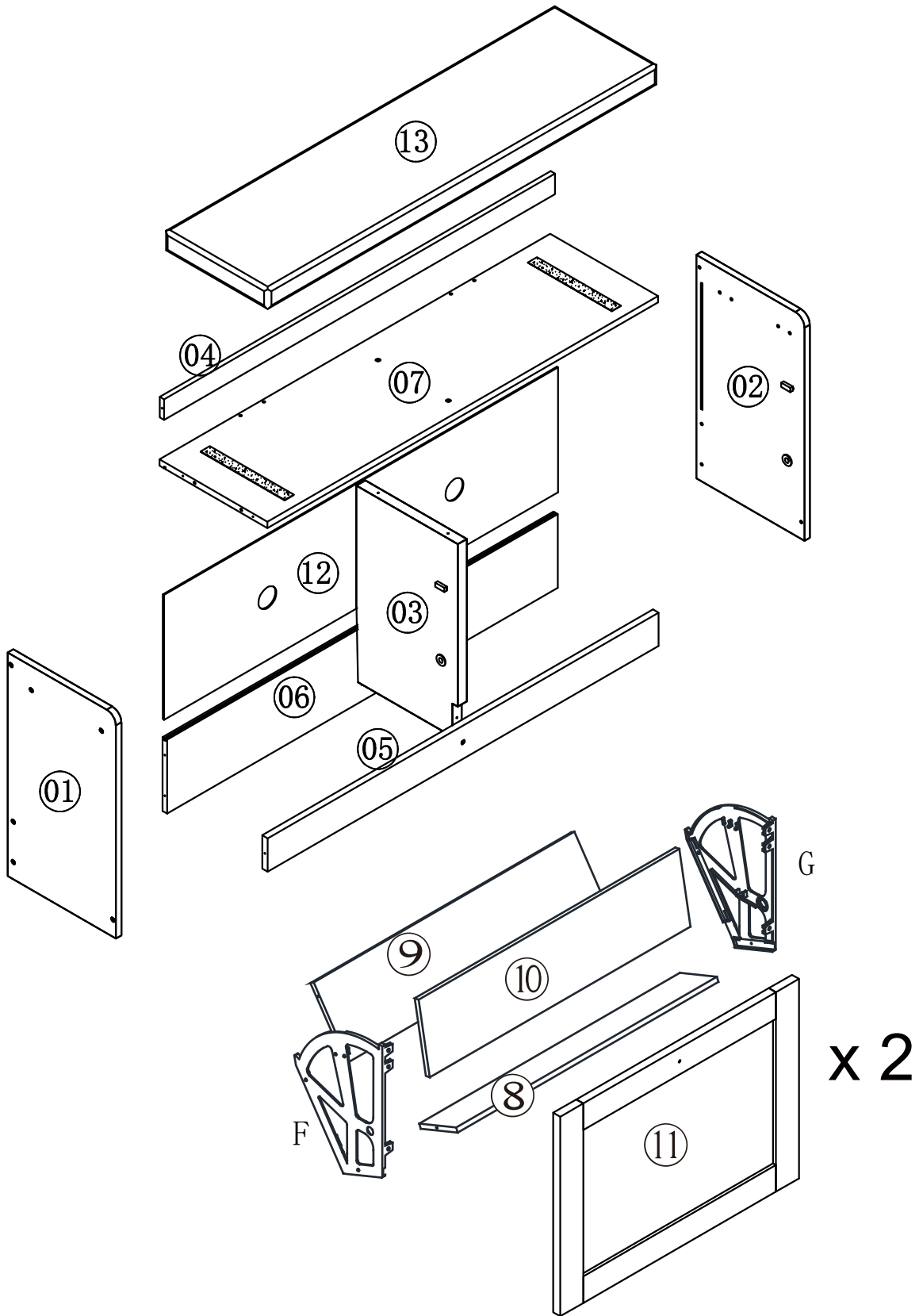

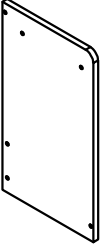
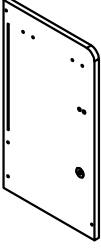
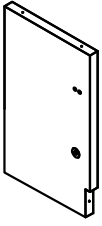
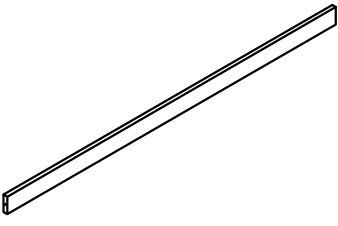
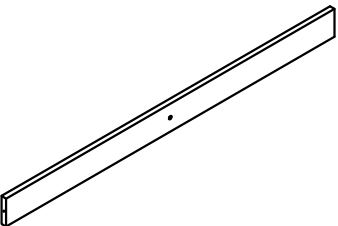
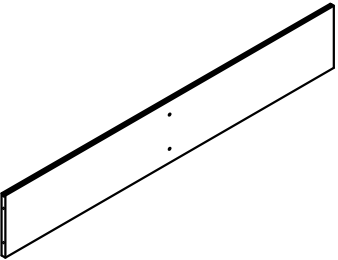
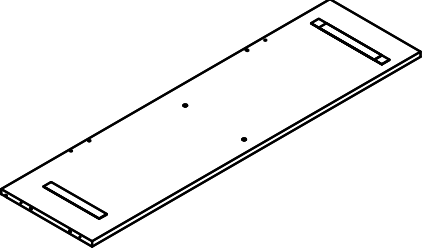
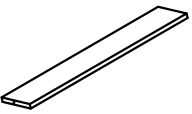
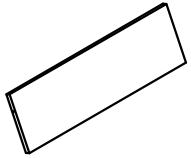
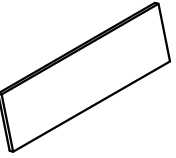
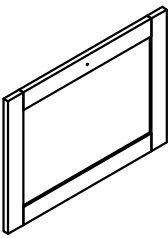
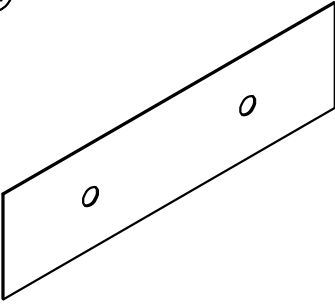
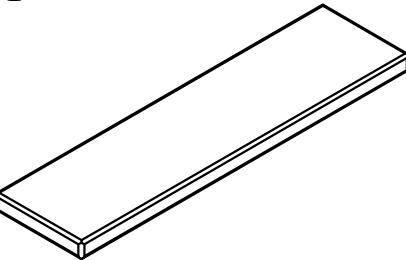

Parts List(EN) / Teile Liste(DE)

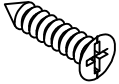
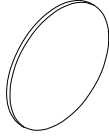
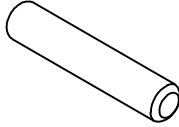

Hardware List (EN) / Teile Liste (DE)

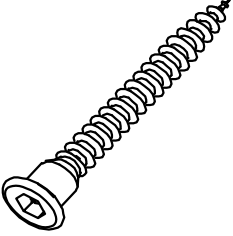
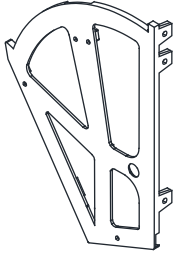
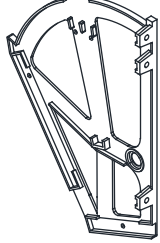
<p>①</p>  <p>530*296*15mm 1 PC</p>	<p>②</p>  <p>530*296*15mm 1 PC</p>	<p>③</p>  <p>464*278*25mm 1 PC</p>
<p>④</p>  <p>1070*49*15mm 1 PC</p>	<p>⑤</p>  <p>1070*79*15mm 1 PC</p>	<p>⑥</p>  <p>1070*175*12mm 1 PC</p>
<p>⑦</p>  <p>1070*296*15mm 1 PC</p>	<p>⑧</p>  <p>511*96*12mm 2 PCS</p>	<p>⑨</p>  <p>511*148*12mm 2 PCS</p>
<p>⑩</p>  <p>511*148*12mm 2 PCS</p>	<p>⑪</p>  <p>373*517*15mm 2 PCS</p>	<p>⑫</p>  <p>1079*298*3mm 1 PC</p>
<p>⑬</p>  <p>1070*281*50mm 1 PC</p>		

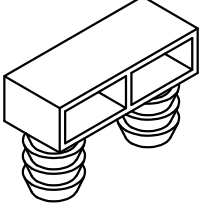
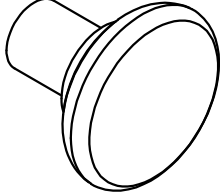
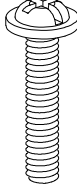
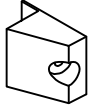
Hardware List (EN) / Teile Liste (DE)

<p>A</p>  <p>$\phi 3.5 \times 16 \text{mm}$ 20PCS</p>	<p>B</p>  <p>$\phi 15 \text{mm}$ 19PCS</p>	<p>C</p>  <p>$\phi 6 \times 30 \text{mm}$ 6PCS</p>	<p>D</p>  <p>$\phi 4 \times 10 \text{mm}$ 4PCS</p>
<p>E</p>  <p>$\phi 5 \times 45 \text{mm}$ 19PCS</p>	<p>F</p>  <p>$290 \times 198 \times 22 \text{mm}$ 2PCS</p>	<p>G</p>  <p>$290 \times 198 \times 22 \text{mm}$ 2PCS</p>	<p>H</p>  <p>$18 \times 10 \text{mm}$ 4PCS</p>
<p>I</p>  <p>$26 \times 18 \times 10 \text{mm}$ 4PCS</p>	<p>J</p>  <p>$\phi 31 \times 28 \text{mm}$ 2PCS</p>	<p>K</p>  <p>$\phi 4 \times 20 \text{mm}$ 2PCS</p>	<p>L</p>  <p>$13 \times 13 \times 11 \text{mm}$ 6PCS</p>
<p>M</p>  <p>M4 1PC</p>	<p>N</p>  <p>$\phi 3 \times 14 \text{mm}$ 6PCS</p>		

Assembly (EN) /Montageschritte (DE)

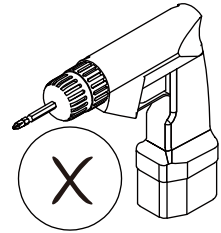
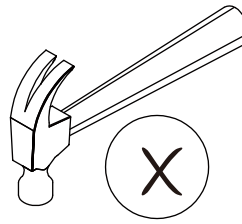
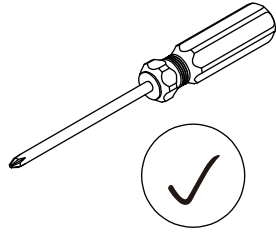
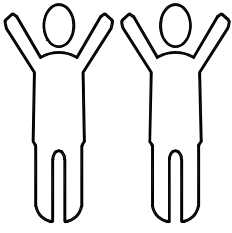

STEP1

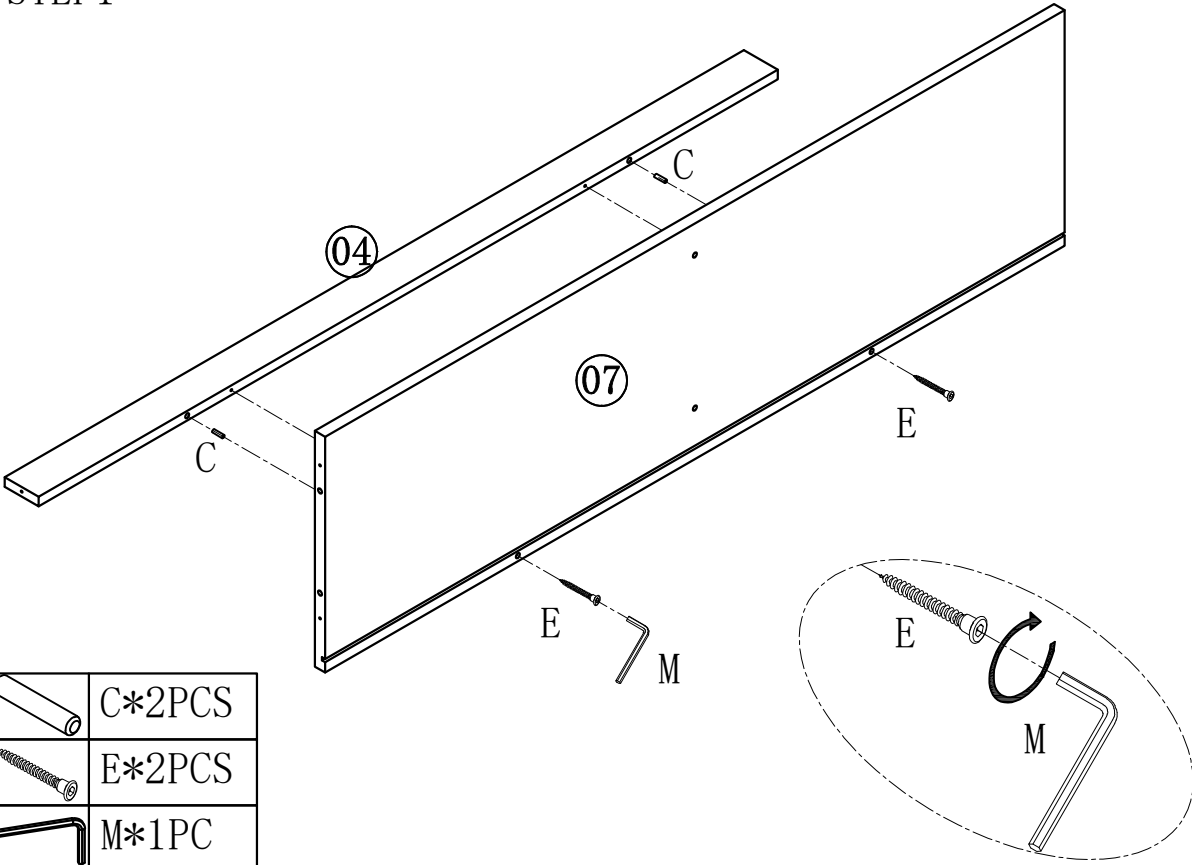

	C*2PCS
	E*2PCS
	M*1PC

STEP2

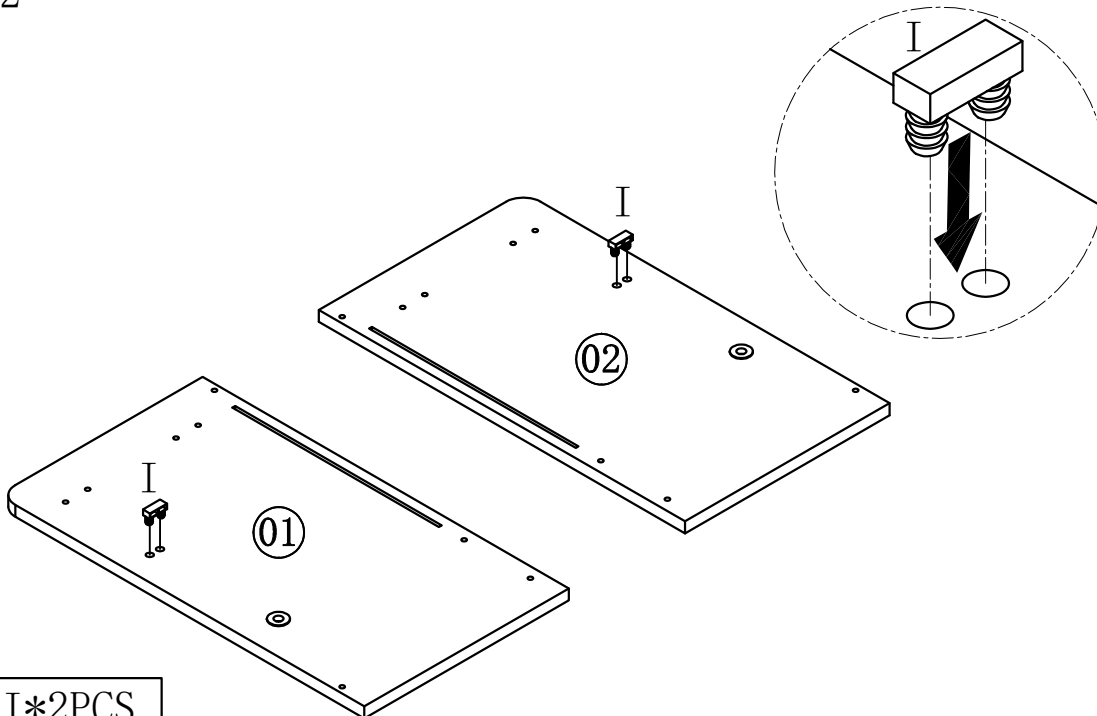

	I*2PCS
--	--------

STEP3

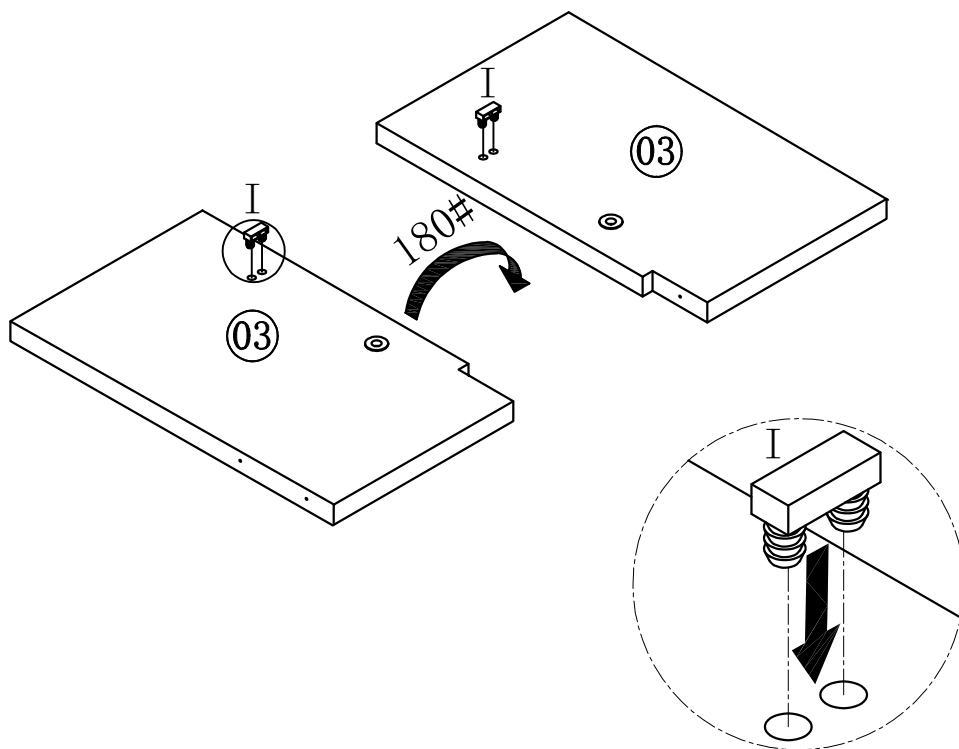

I*2PCS

STEP4

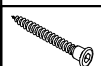
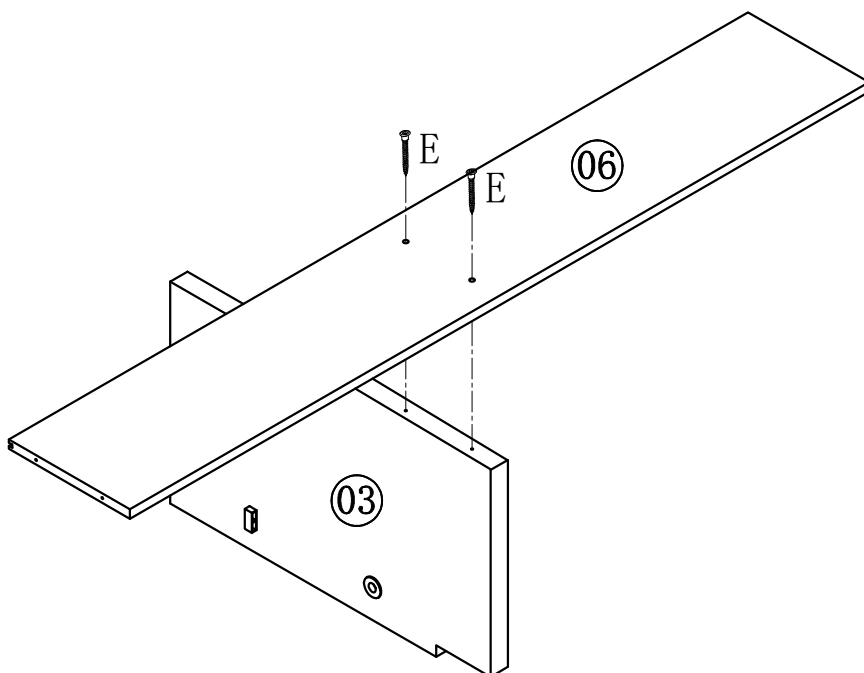

E*2PCS

STEP5

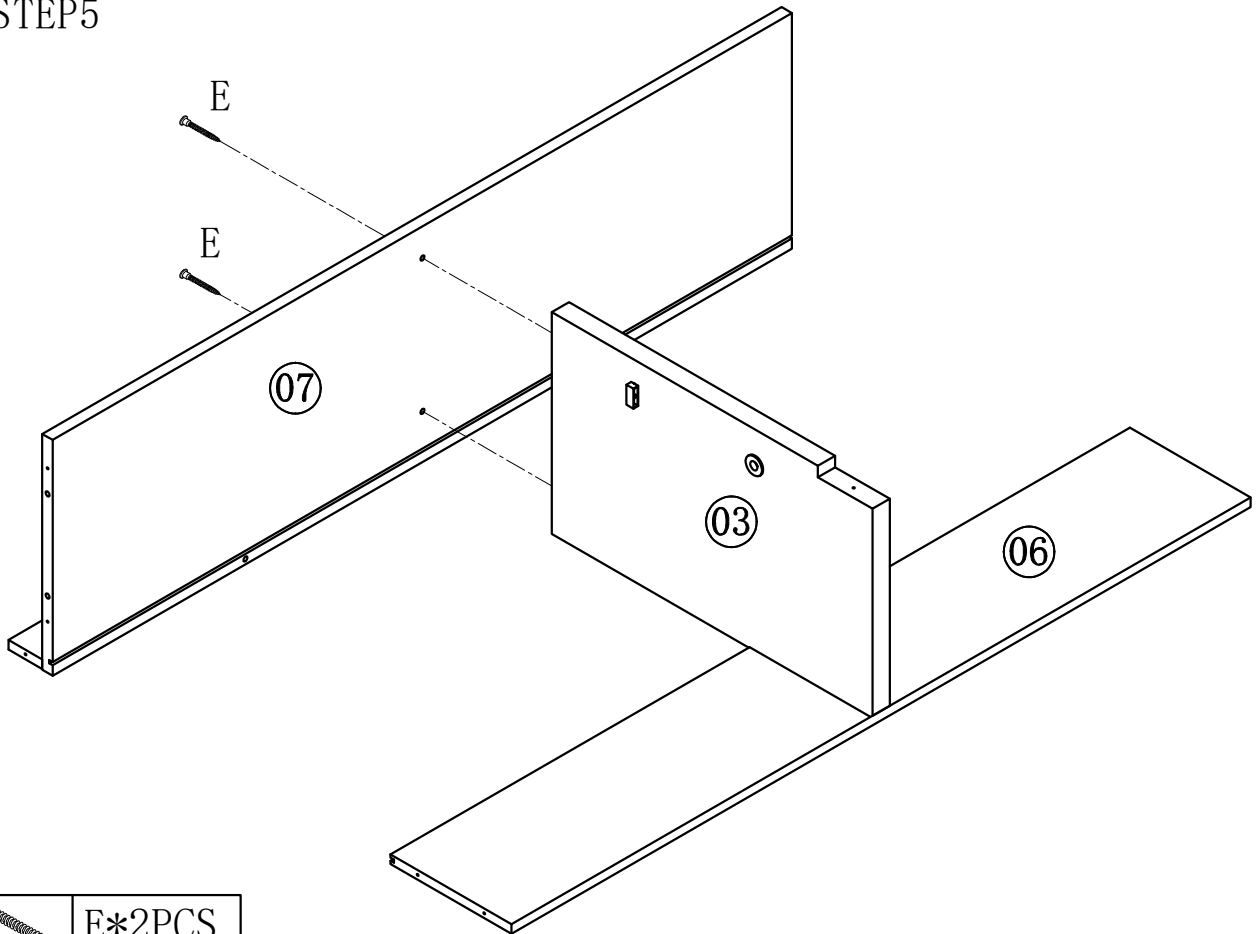

 E*2PCS

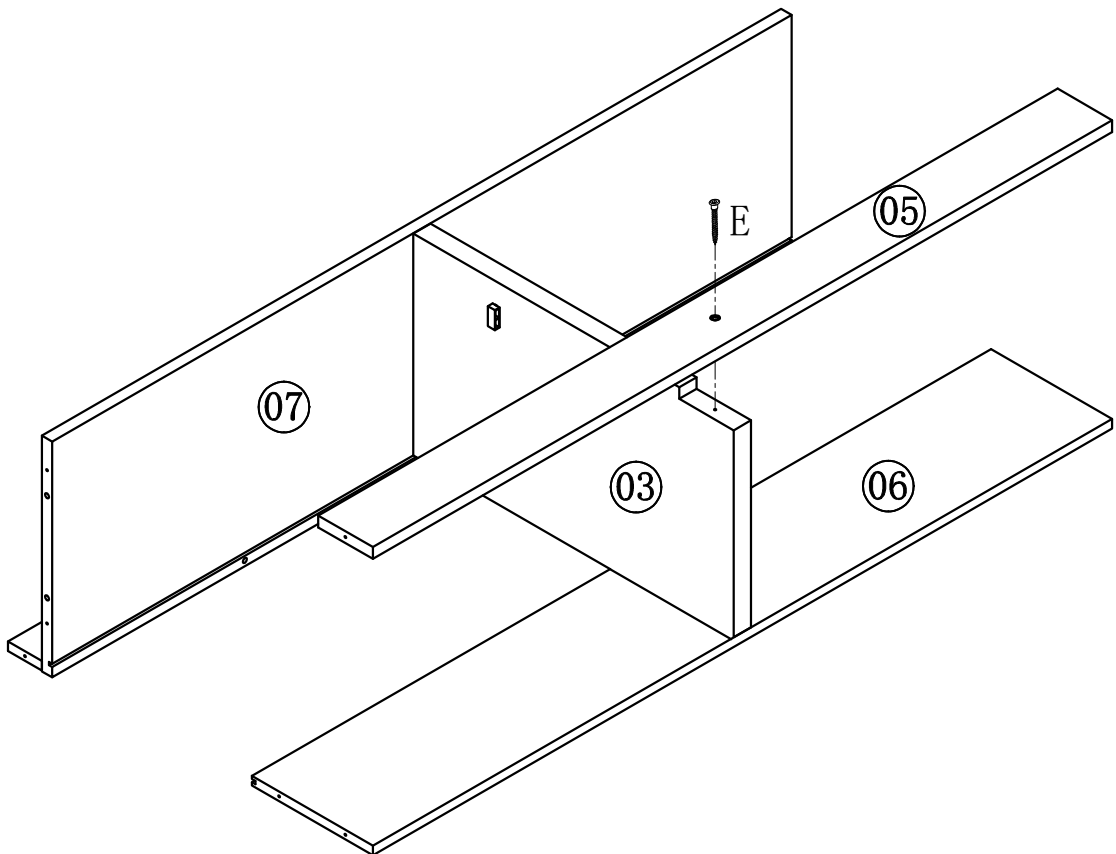

STEP6

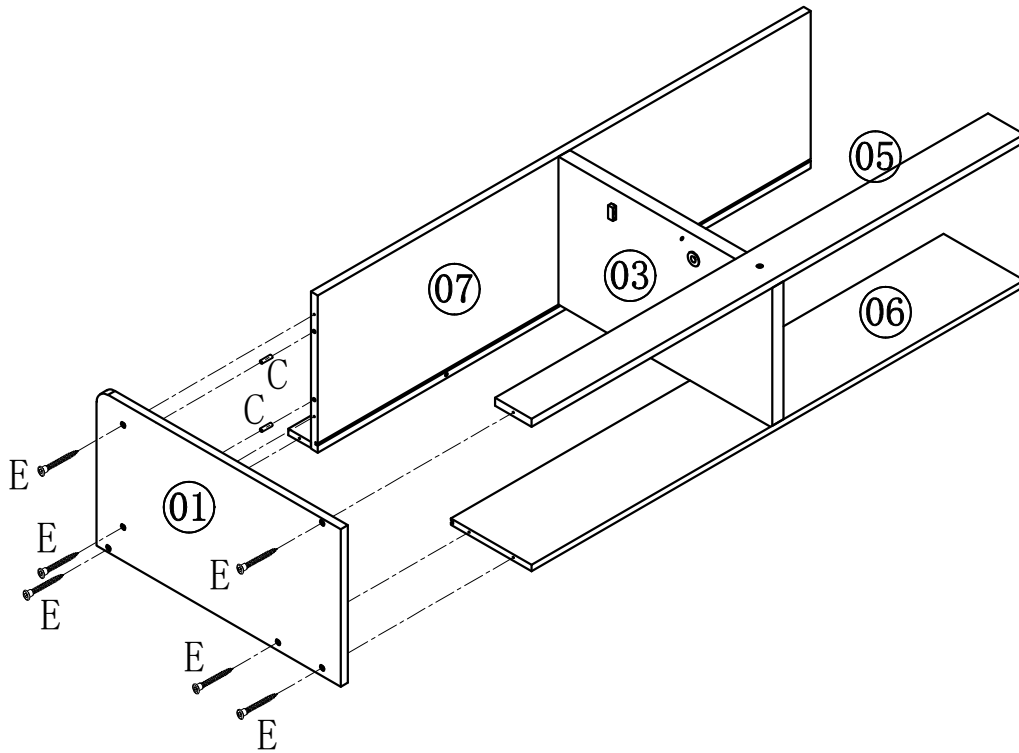

 E*1PC

STEP7



	C*2PCS
	E*6PCS

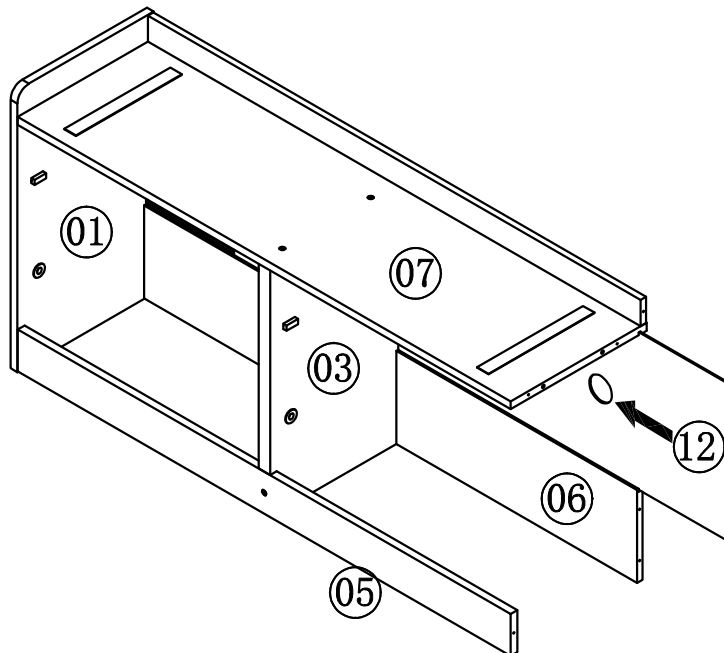

STEP8



Thin back board needs to be inside the slot, otherwise blocks the opposite plate montage.

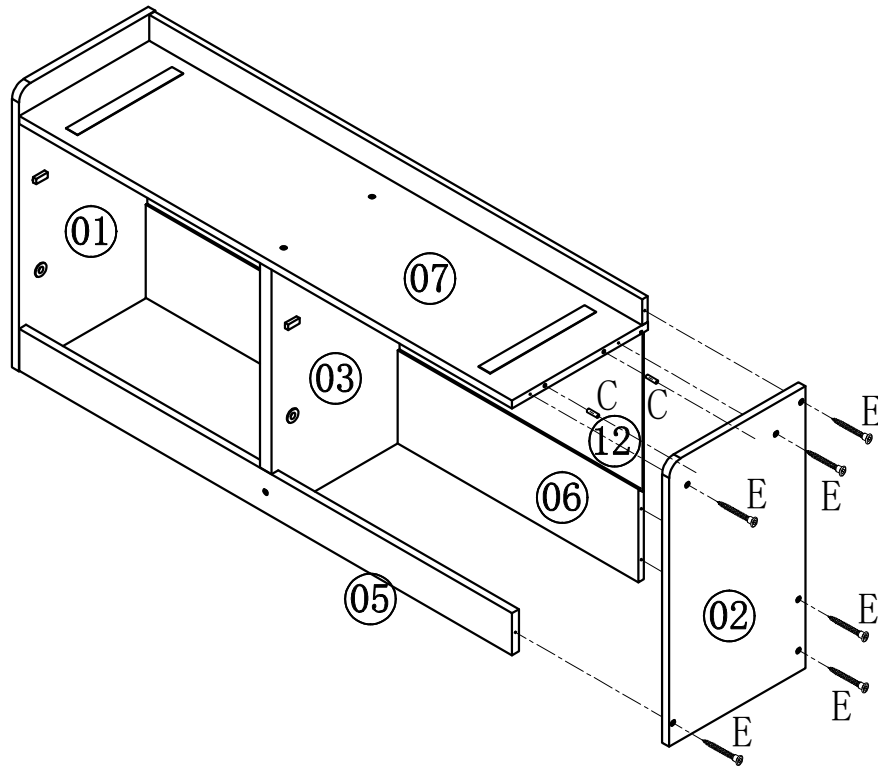

STEP9

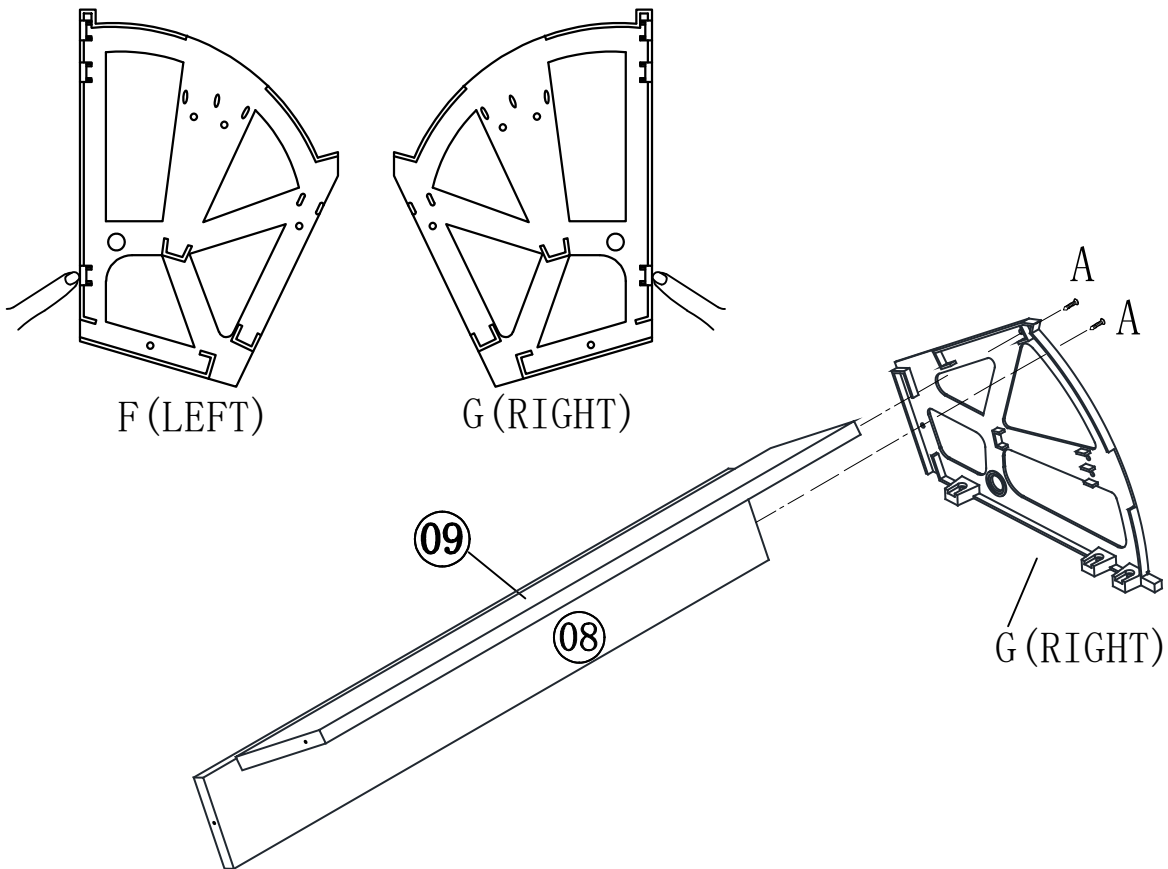

	C*2PCS
	E*6PCS

STEP10





	A*4 PCS
	G*2PCS

X2

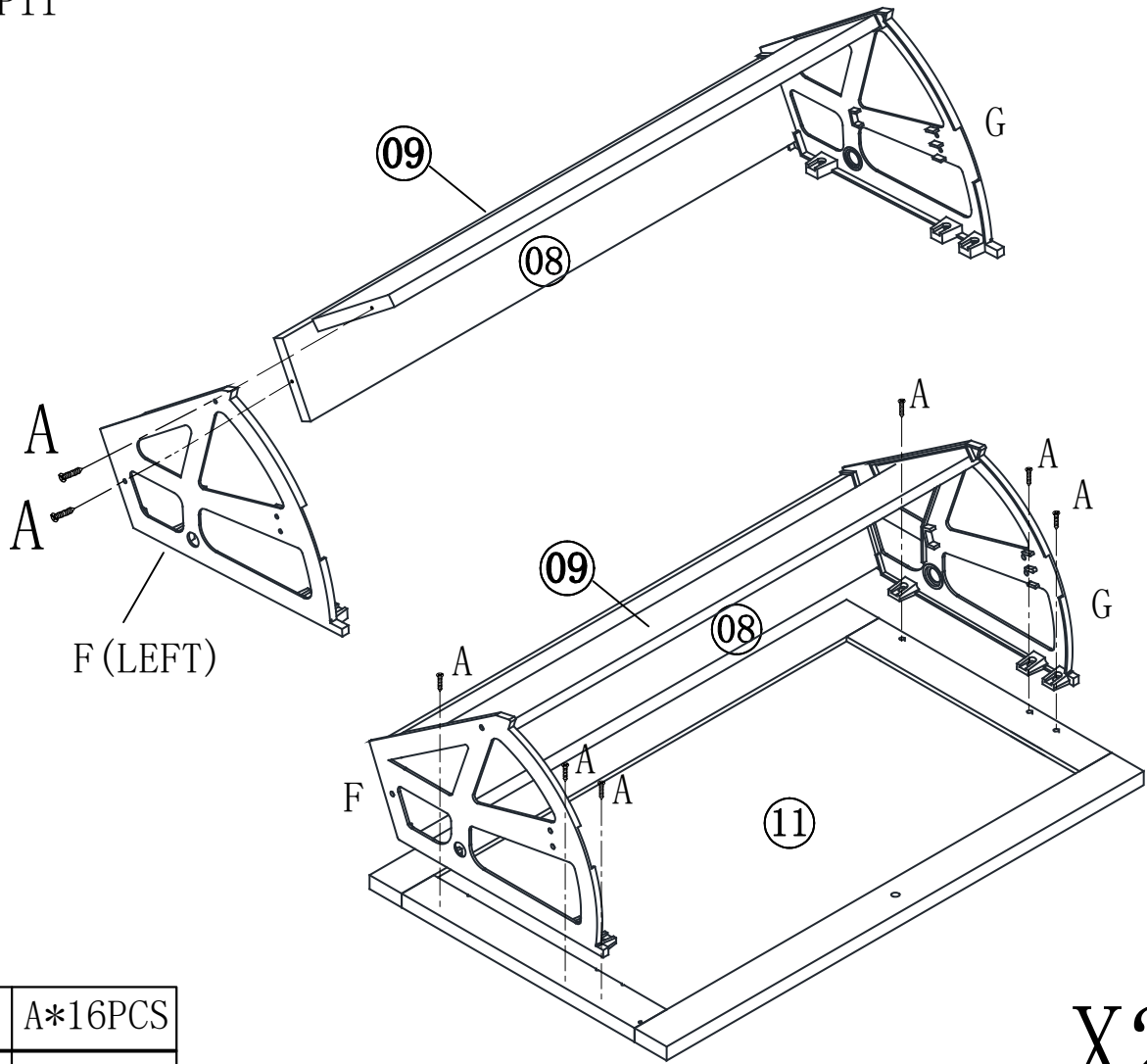
STEP11





X2

	A*16PCS
	F*2PCS

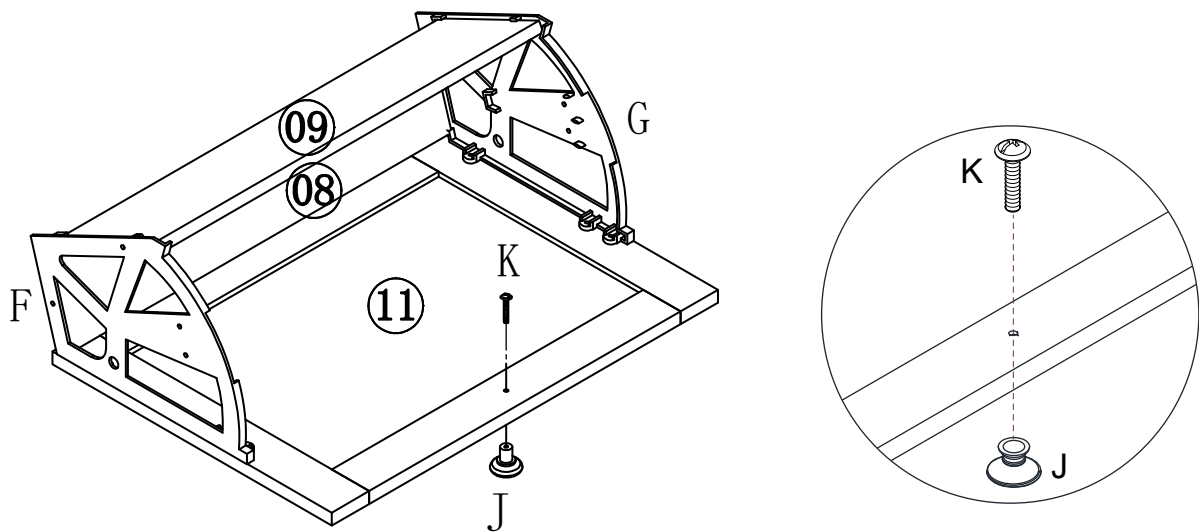
STEP12



X2

	J*2PCS
	K*2PCS

STEP13

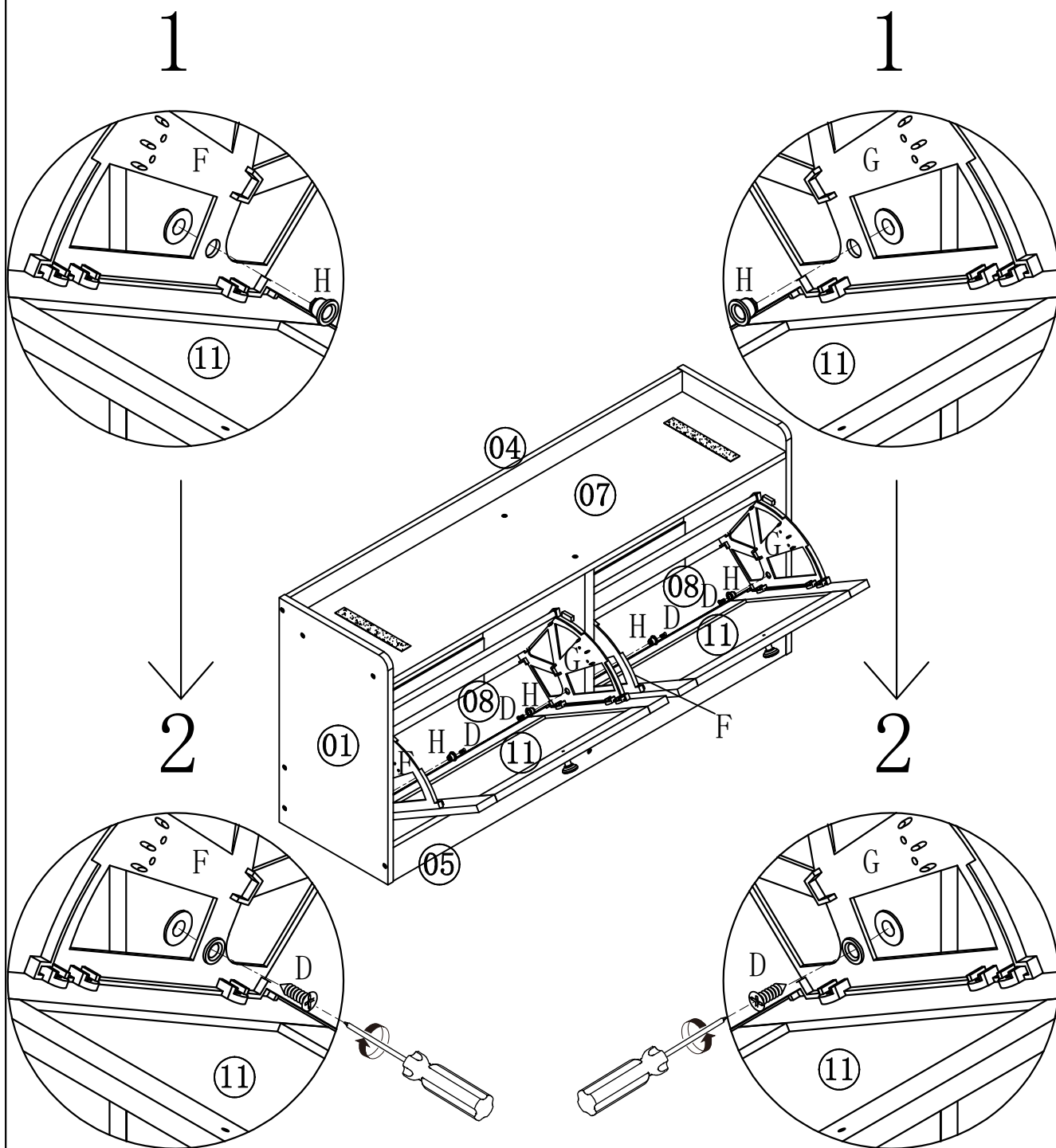

	D*4PCS
	H*4PCS

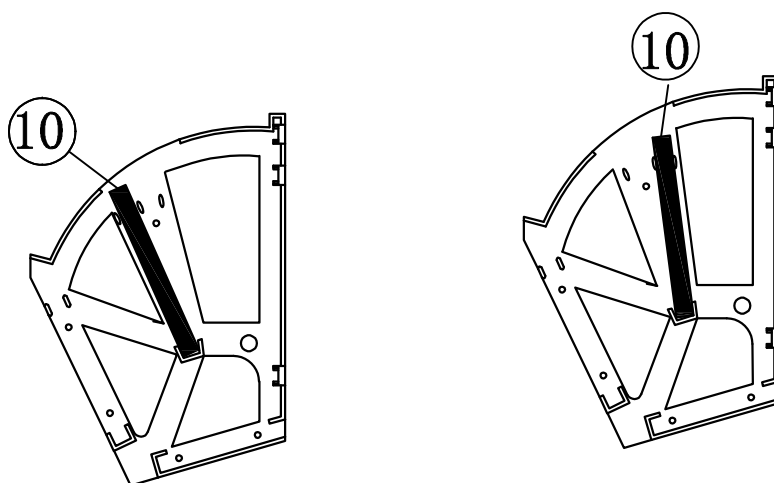
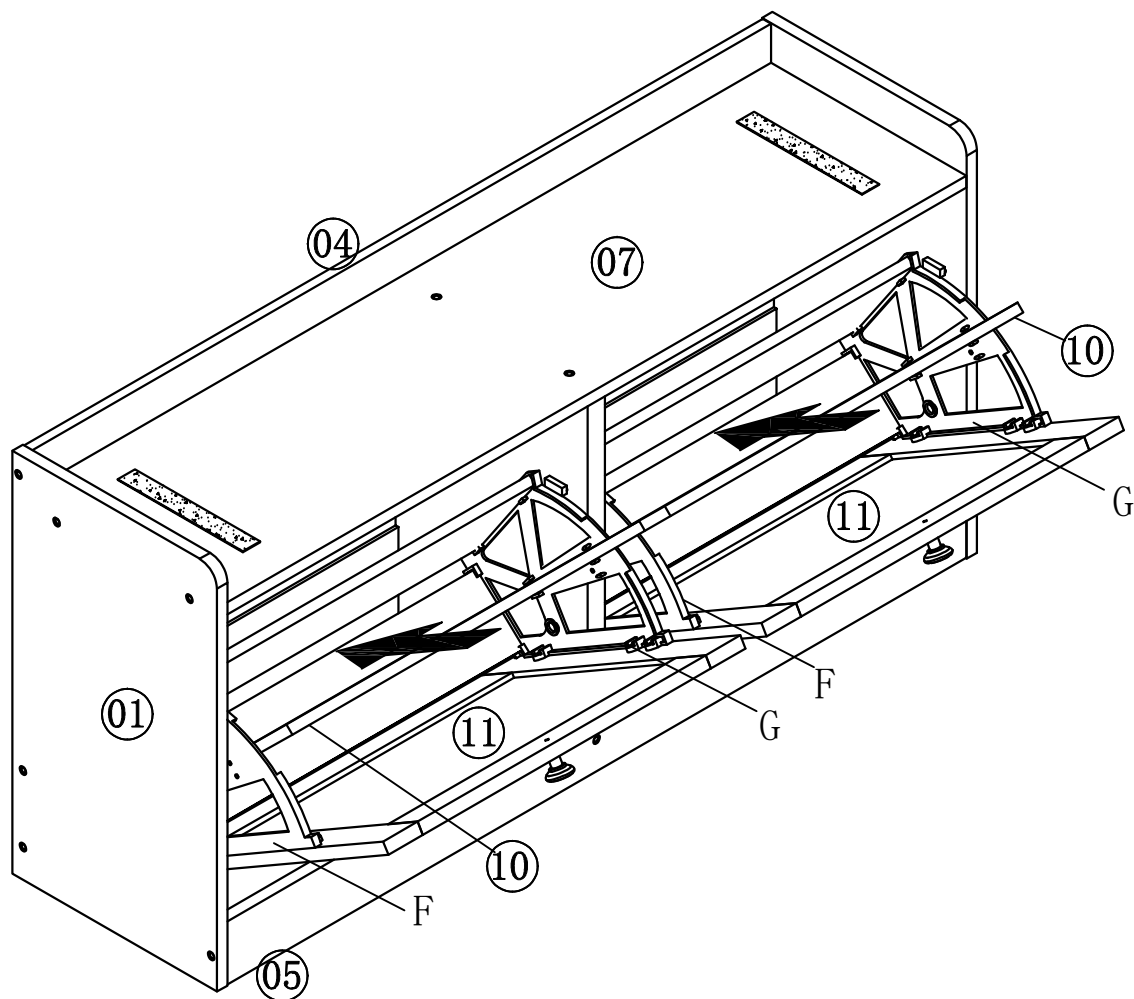

STEP14

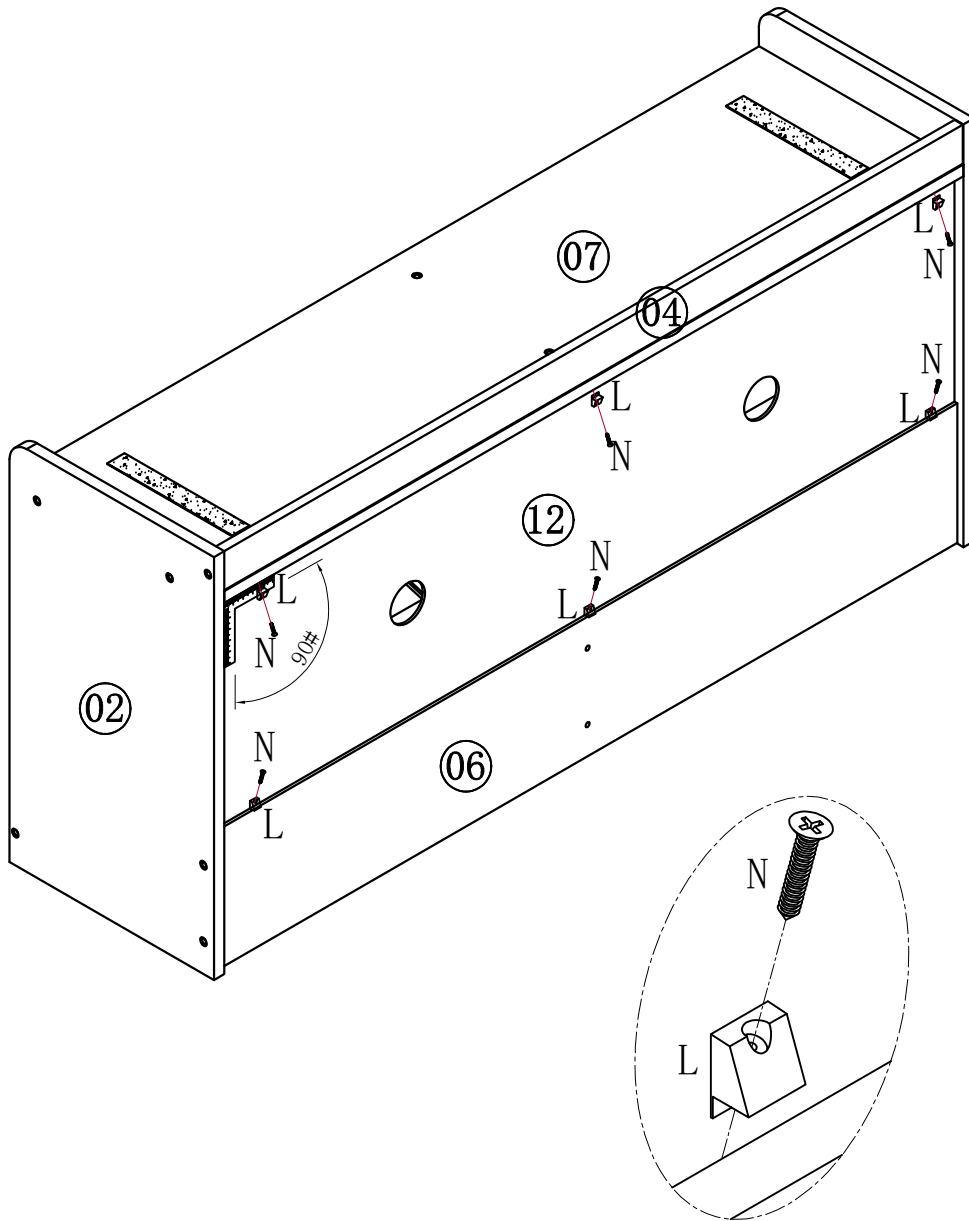

 **Adjustable shelf for various size of shoes.**

STEP15



	N*6PCS
	L*6PCS

STEP16

The zipper is placed on the back.

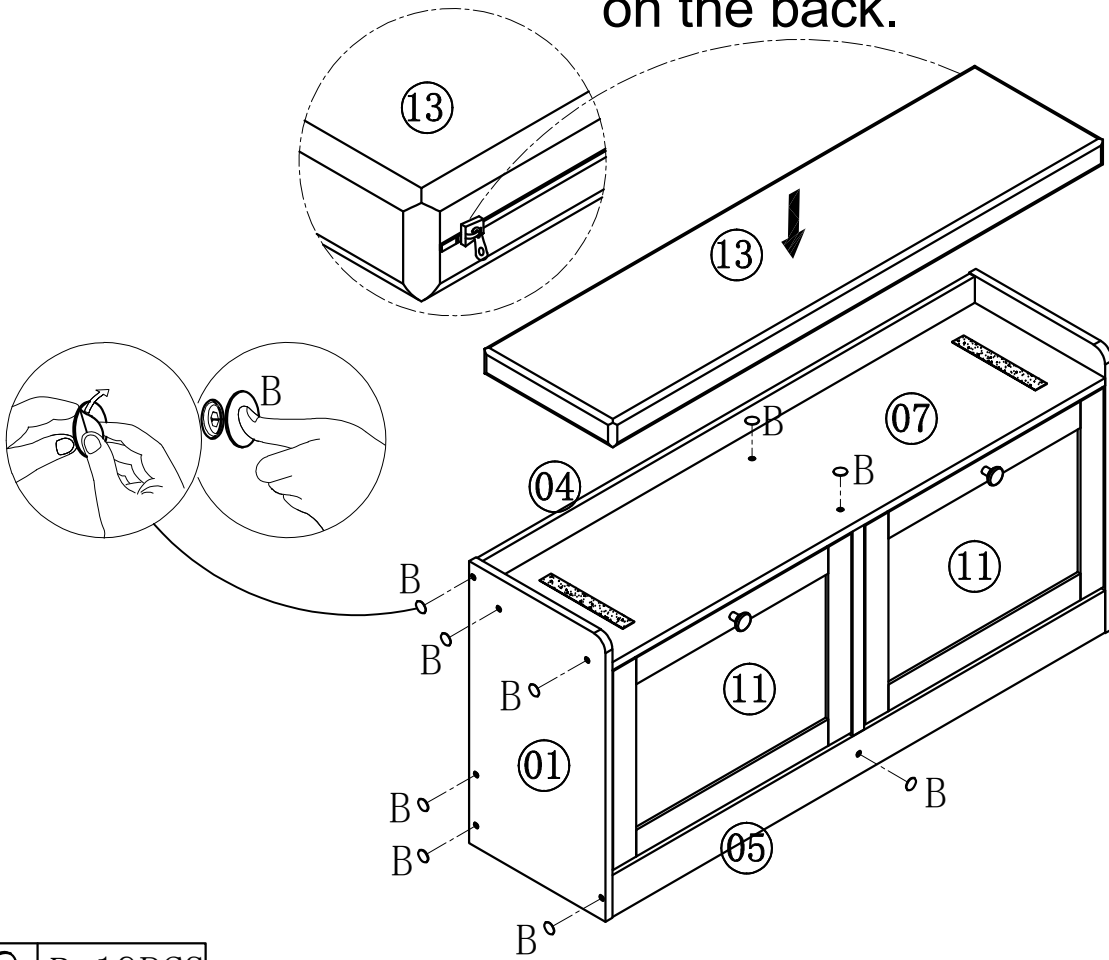

 B*19PCS

STEP17

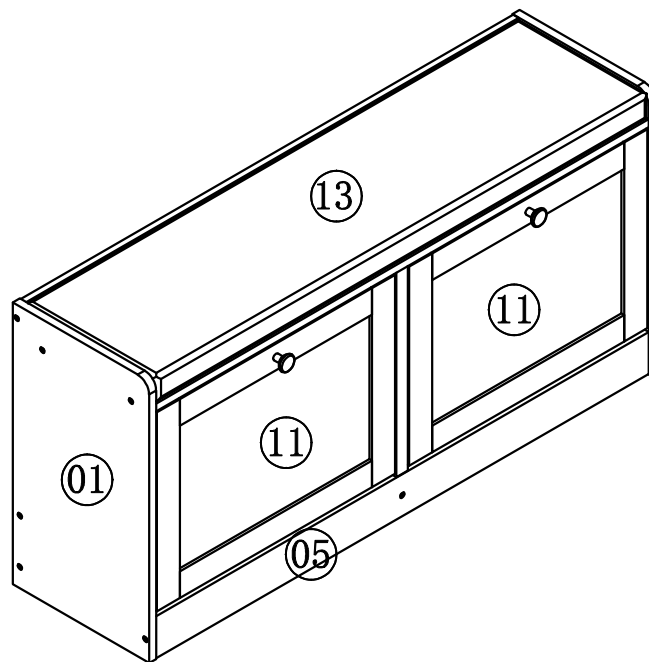

Finish