

Montageanleitung | Instructions de montage Assembly Instructions | Instrucciones de montaje

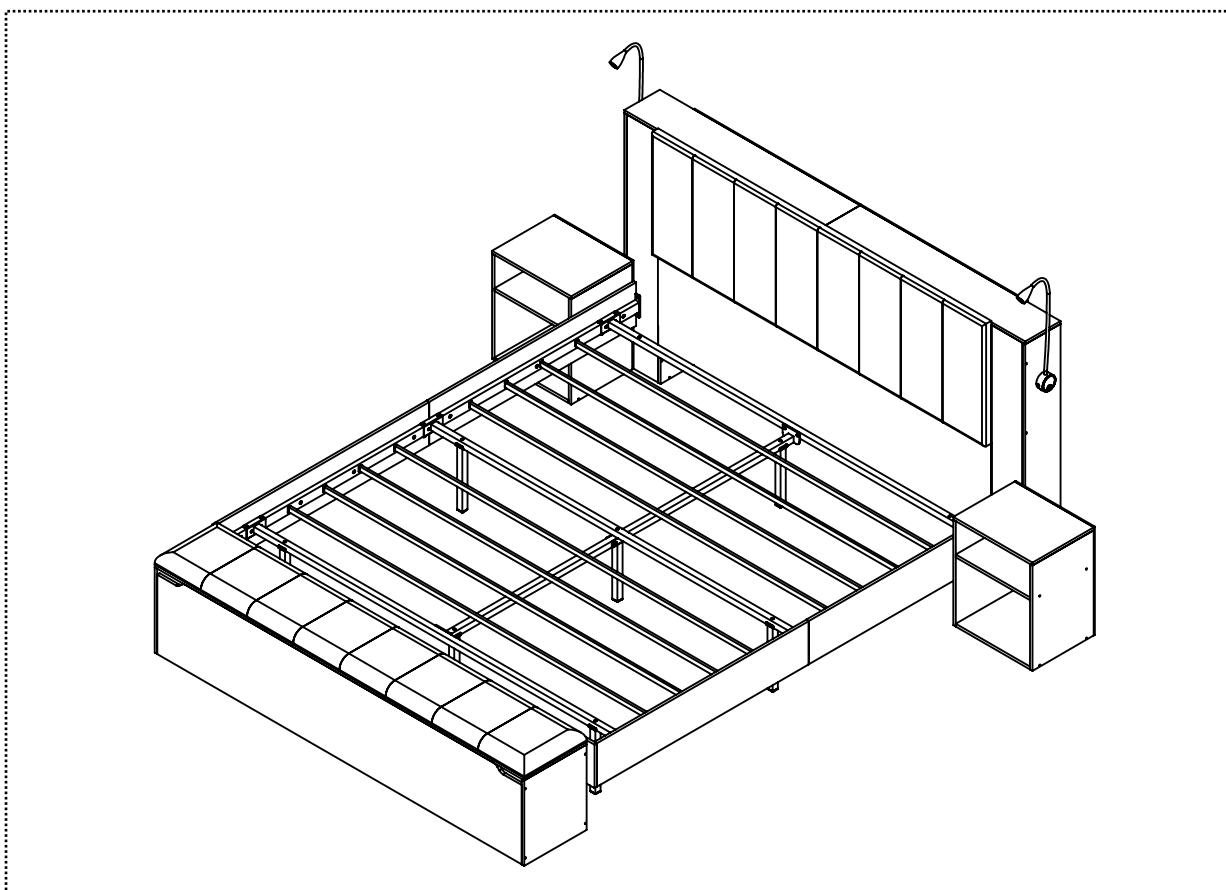

DE Unser Produkt wird Ihnen in 4 Paketen geliefert. Die Lieferzeiten dieser 4 Pakete können abweichen, bitte haben Sie etwas Geduld und vielen Dank für Ihr Verständnis.

UK Our product will be delivered to you in 4 packages. The delivery times of these 4 packages may differ, please be patient and thank you for your understanding.

FR Notre produit vous sera livré en 4 colis. Les délais de livraison de ces 4 colis peuvent différer, soyez patient et merci pour votre compréhension.

IT Il nostro prodotto verrà consegnato in 4 pacchi. I tempi di consegna di questi 4 pacchi possono variare; vi preghiamo di avere un po' di pazienza e vi ringraziamo per la vostra comprensione.

ES Nuestro producto se entregará en 4 paquetes. Los tiempos de entrega de estos 4 paquetes pueden variar; por favor, tenga un poco de paciencia y gracias por su comprensión.

NL Ons product wordt in 4 pakketten bij u geleverd. De levertijden van deze 4 pakketten kunnen verschillen, we vragen om uw geduld en bedanken u voor uw begrip.

SE Vår produkt kommer att levereras till dig i 4 paket. Leveranstiderna för dessa 4 paket kan variera, vi ber om ditt tålamod och tackar för din förståelse.

PL Nasz produkt zostanie dostarczony w 4 paczkach. Czas dostawy tych 4 paczek może się różnić, prosimy o cierpliwość i dziękujemy za zrozumienie.

English

IMPORTANT ! KEEP FOR FUTURE REFERENCE : READ CAREFULLY

- To be assembled by an adult. Assembly must be checked by an adult before use
- WARNING ! Keep all screws, small parts and plastic bags out of the reach of children
- Properly identify all parts before assembling
- Never use your item if any of its parts are broken or missing
- Should any problems arise, please contact our After Sales Service
- Manufacturer's instructions shall be followed at all times
- Care: Clean with a soft, dry cloth. In case of larger stains, carefully rub with a slightly damp, non-abrasive sponge
- Avoid the risk of fire by not placing furniture near sources of ignition or hot items
- Do not jump on the bed

Deutsch

WICHTIG ! ZUM SPÄTEREN NACHSCHLAGEN AUFBEWAHREN: SORGFÄLTIG LESEN

- Muss von einem Erwachsenen zusammengebaut werden. Der Zusammenbau muss vor dem Gebrauch von einem Erwachsenen überprüft werden
- WARNUNG! Bewahren Sie alle Schrauben, Kleinteile und Plastikbeutel außerhalb der Reichweite von Kindern auf
- Kennzeichnen Sie vor dem Zusammenbau alle Teile richtig
- Benutzen Sie Ihren Artikel niemals, wenn Teile gebrochen sind oder fehlen
- Sollten Probleme auftreten, wenden Sie sich bitte an unseren Kundendienst
- Die Anweisungen des Herstellers sind stets zu befolgen
- Pflege: Mit einem weichen, trockenen Tuch reinigen. Bei größeren Flecken vorsichtig mit einem leicht feuchten, nicht scheuernden Schwamm abreiben. nicht scheuernden Schwamm
- Vermeiden Sie die Gefahr eines Brandes, indem Sie die Möbel nicht in der Nähe von Zündquellen oder heißen Gegenständen aufstellen
- Nicht auf das Bett springen

Français

IMPORTANT ! CONSERVER POUR RÉFÉRENCE ULTÉRIEURE : LIRE ATTENTIVEMENT

- Le montage doit être effectué par un adulte. Le montage doit être vérifié par un adulte avant Utilisation
- ATTENTION ! Tenir les vis, les petites pièces et les sachets en plastique hors de portée des enfants
- Identifiez correctement toutes les pièces avant de les assembler
- N'utilisez jamais votre article si l'une de ses pièces est cassée ou manquante
- En cas de problème, veuillez contacter notre service après-vente
- Les instructions du fabricant doivent être respectées à tout moment
- Entretien : nettoyer avec un chiffon doux et sec. En cas de taches plus importantes, frotter soigneusement avec une éponge non abrasive légèrement humide. légèrement humide et non Abrasive
- Évitez les risques d'incendie en ne plaçant pas les meubles à proximité de sources d'inflammation ou d'objets chauds
- Ne pas sauter sur le lit

Italiano

IMPORTANTE! CONSERVARE PER RIFERIMENTO FUTURO: LEGGERE ATTENTAMENTE

- Deve essere assemblato da un adulto. L'assemblaggio deve essere controllato da un adulto prima dell'uso
- **ATTENZIONE!** Tenere tutte le viti, le piccole parti e i sacchetti di plastica fuori dalla portata dei bambini
- Identificare correttamente tutte le parti prima dell'assemblaggio
- Non utilizzare mai l'articolo se alcune parti sono rotte o mancanti
- In caso di problemi, si prega di contattare il nostro Servizio Post Vendita
- Le istruzioni del produttore devono essere sempre seguite
- Cura: Pulire con un panno morbido e asciutto. In caso di macchie più estese, strofinare accuratamente con una spugna leggermente umida e nonspugna leggermente umida e non abrasiva
- Evitare il rischio di incendio, non collocando i mobili vicino a fonti di accensione o a oggetti caldi
- Non saltare sul letto

Español

¡ IMPORTANTE ! CONSERVELO PARA FUTURAS CONSULTAS: LEA ATENTAMENTE

- Debe ser montado por un adulto. El montaje debe ser comprobado por un adulto antes del uso
- ADVERTENCIA Mantenga todos los tornillos, piezas pequeñas y bolsas de plástico fuera del alcance de los niños.
- Identifique correctamente todas las piezas antes de montarlas
 - Nunca utilice su artículo si alguna de sus piezas está rota o falta
 - Si surge algún problema, póngase en contacto con nuestro Servicio Postventa
 - Las instrucciones del fabricante deben seguirse en todo momento
 - Cuidado: Limpiar con un paño suave y seco. En caso de manchas más grandes, frote cuidadosamente con una esponja no abrasiva ligeramente humedecida.
 - Evite el riesgo de incendio no colocando los muebles cerca de fuentes de ignición u objetos calientes.
 - No saltar sobre la cama.

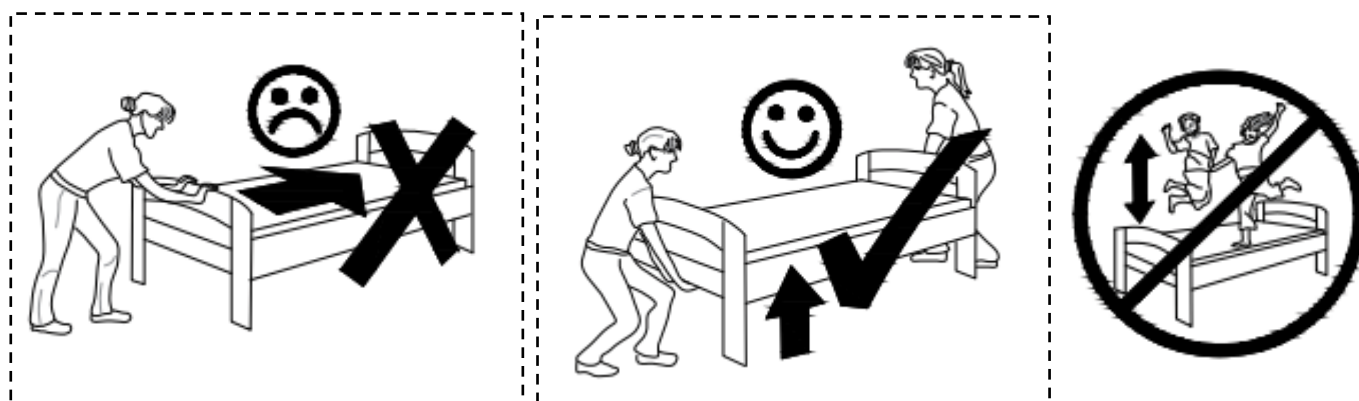

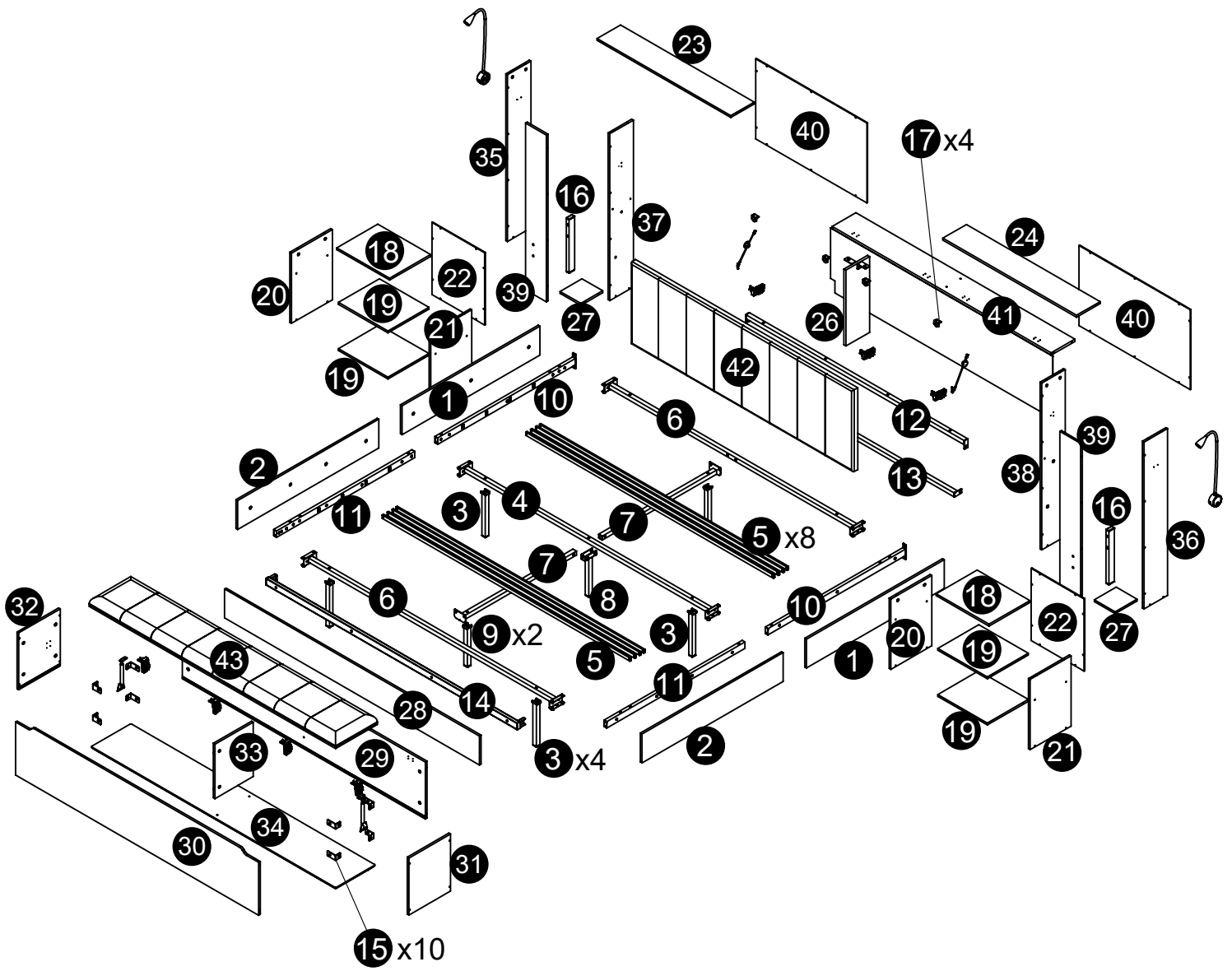

Part List

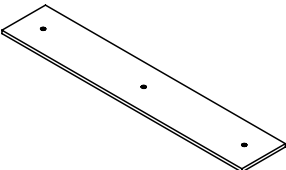
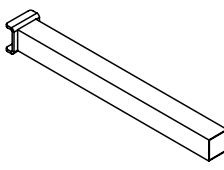
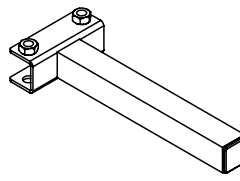
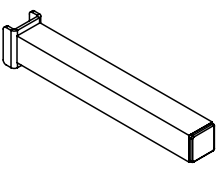
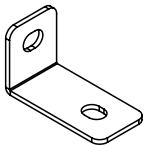
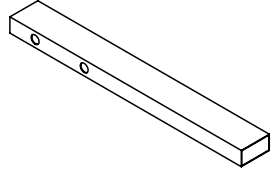
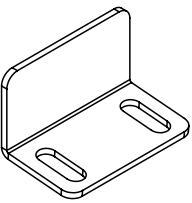
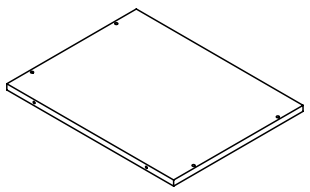
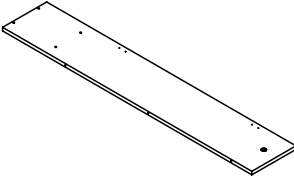
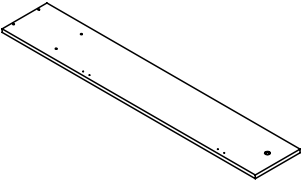
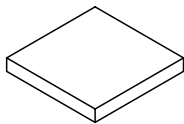
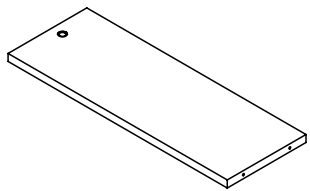
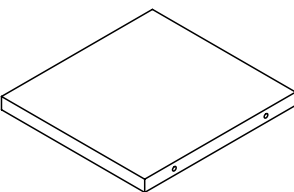
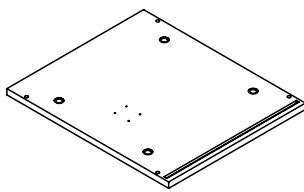
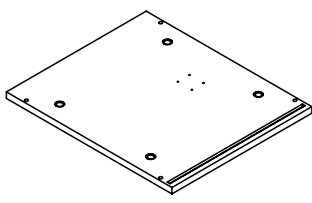
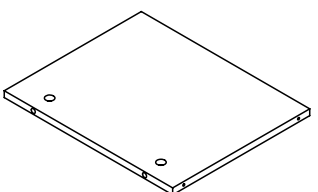
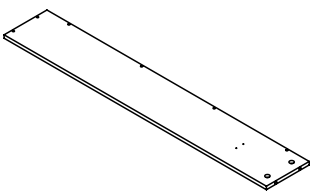
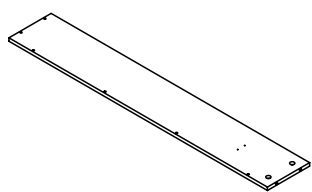
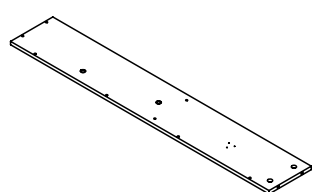
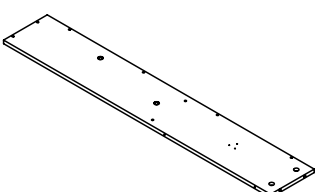
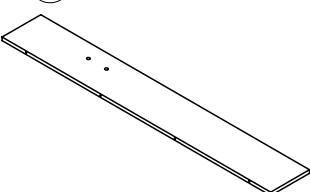
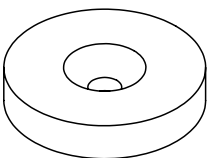
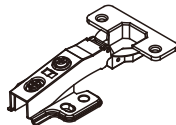
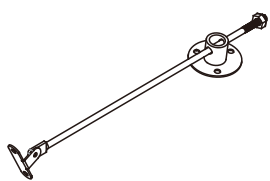
<p>① X2</p> 	<p>③ X4</p> 	<p>⑧ X1</p> 	<p>⑨ X2</p> 
<p>⑮ X10</p> 	<p>⑯ X2</p> 	<p>⑰ X4</p> 	<p>⑱ X2</p> 
<p>⑳ X1</p> 	<p>㉑ X1</p> 	<p>㉒ X24</p> 	<p>㉓ X1</p> 
<p>㉗ X2</p> 	<p>㉙ X1</p> 	<p>㉚ X1</p> 	<p>㉛ X1</p> 
<p>㉝ X1</p> 	<p>㉞ X1</p> 	<p>㉟ X1</p> 	<p>㊱ X1</p> 
<p>㊳ X2</p> 	<p>㊴ X4</p> 	<p>㊵ X8</p>  <p>ST4. 2x12</p>	<p>㊶ X2</p> 

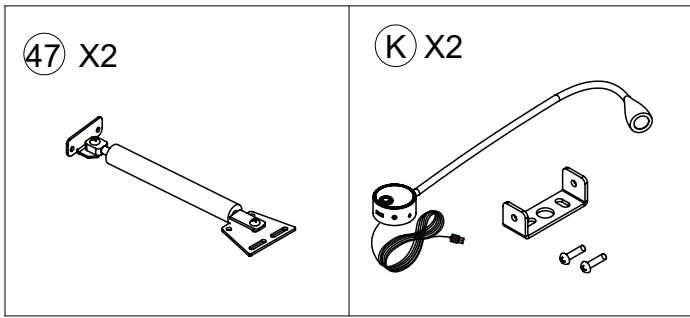

Part List

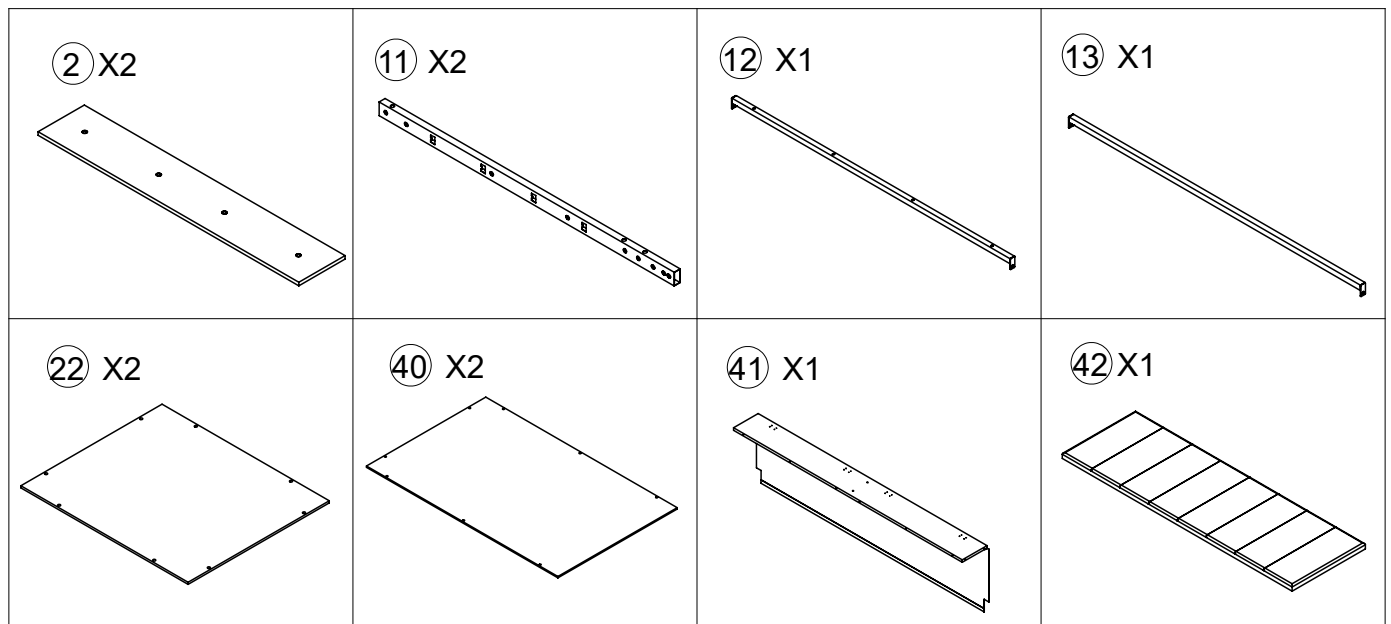



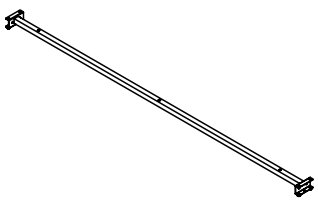
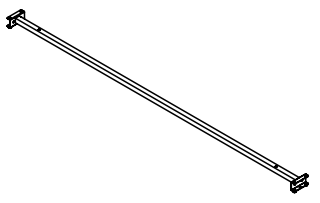
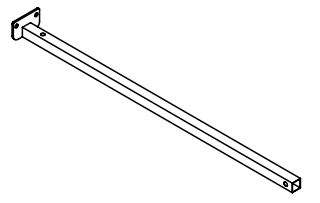
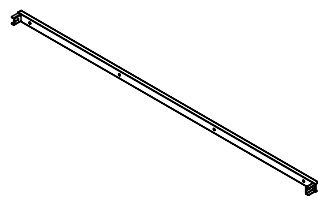
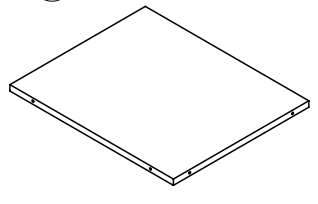
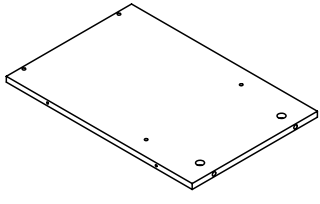
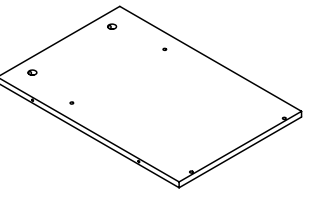
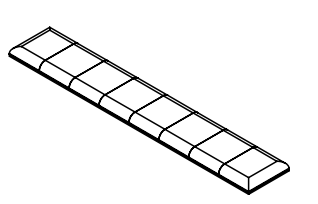



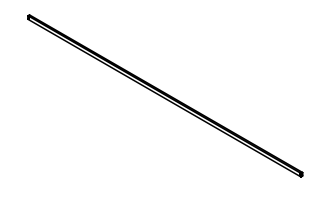
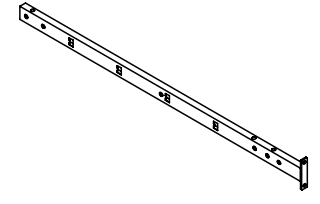
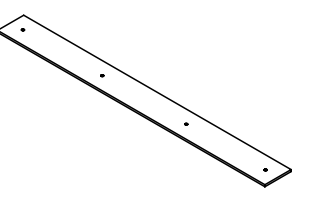
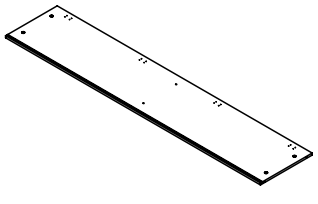
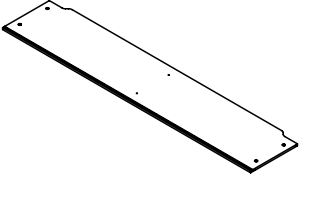
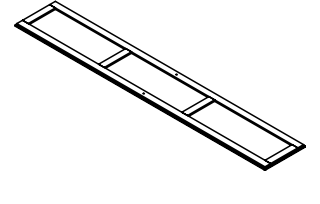





Part List

<p>④ X1</p> 	<p>⑥ X2</p> 	<p>⑦ X2</p> 	<p>⑭ X1</p> 
<p>⑲ X4</p> 	<p>⑳ X2</p> 	<p>㉑ X2</p> 	<p>④③ X1</p> 

Part List

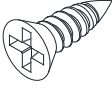
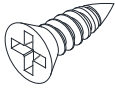
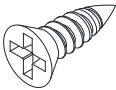

<p>⑤ X8</p> 	<p>⑩ X2</p> 	<p>⑳ X1</p> 	<p>㉑ X1</p> 
<p>⑳ X1</p> 	<p>㉒ X1</p> 		

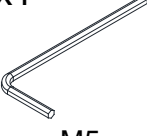
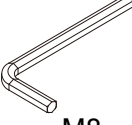
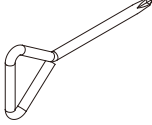
Hardware List

<p>A x20</p>  <p>M8X12</p>	<p>B x24</p>  <p>M8X14</p>	<p>C x18</p>  <p>M8X30</p>	<p>D x4</p>  <p>M8X33</p>	<p>E x8</p>  <p>M8X40</p>
<p>F x17</p>  <p>M8X60</p>	<p>G x90</p>  <p>M5X40</p>	<p>H x14</p>  <p>ST3.2X12</p>	<p>I x4</p>  <p>ST3.2X16</p>	<p>J x12</p>  <p>ST4X12</p>
<p>L x4</p>  <p>ST4X14</p>	<p>M x36</p>  <p>ST4X16</p>	<p>N x18</p>  <p>Φ7*40</p>	<p>O x18</p>  <p>Φ15*10</p>	<p>P x16</p> 
<p>Q x1</p>  <p>M5</p>	<p>R x1</p>  <p>M8</p>	<p>S x1</p> 		

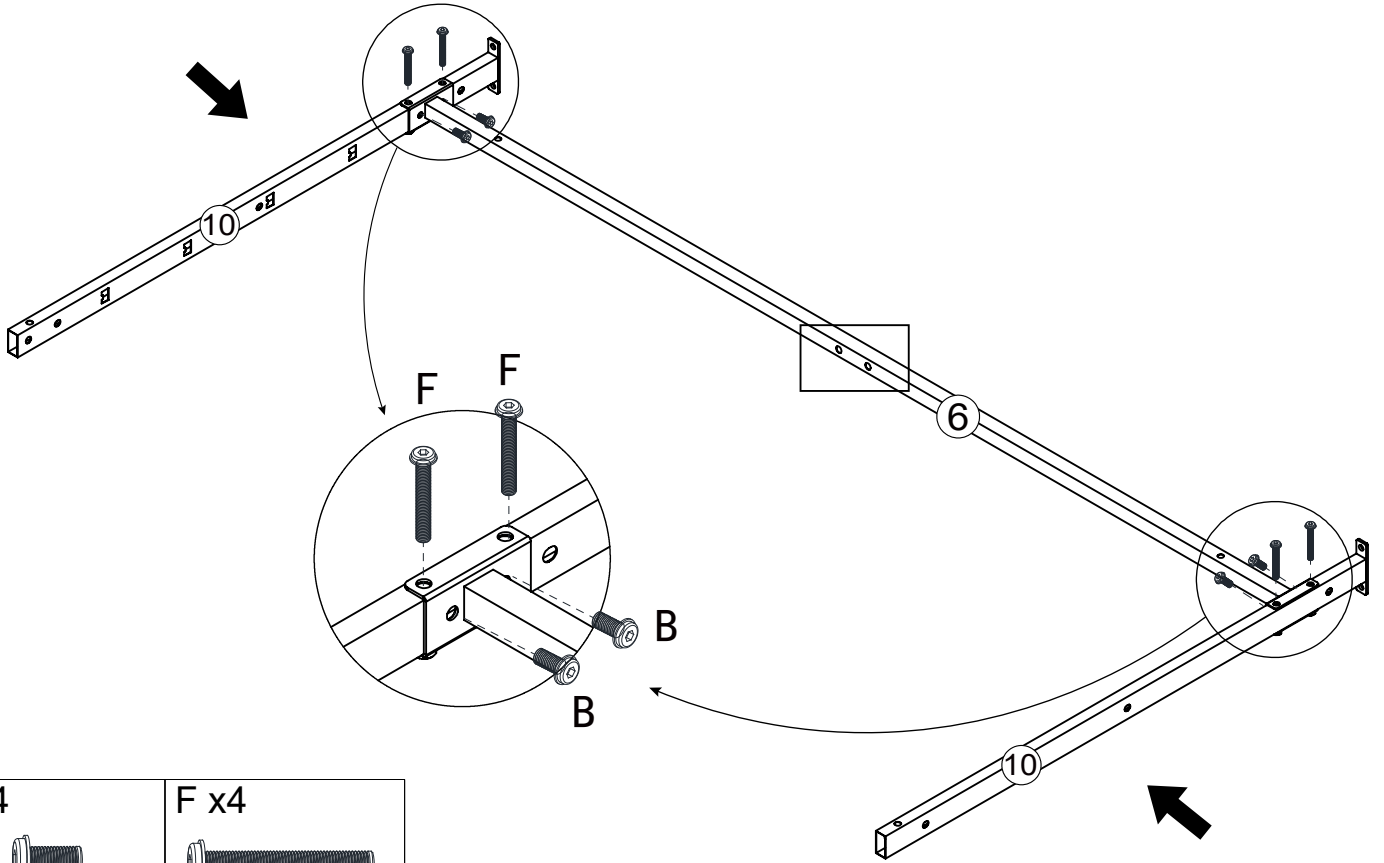
1



B x4	F x4
	
M8X14	M8X60

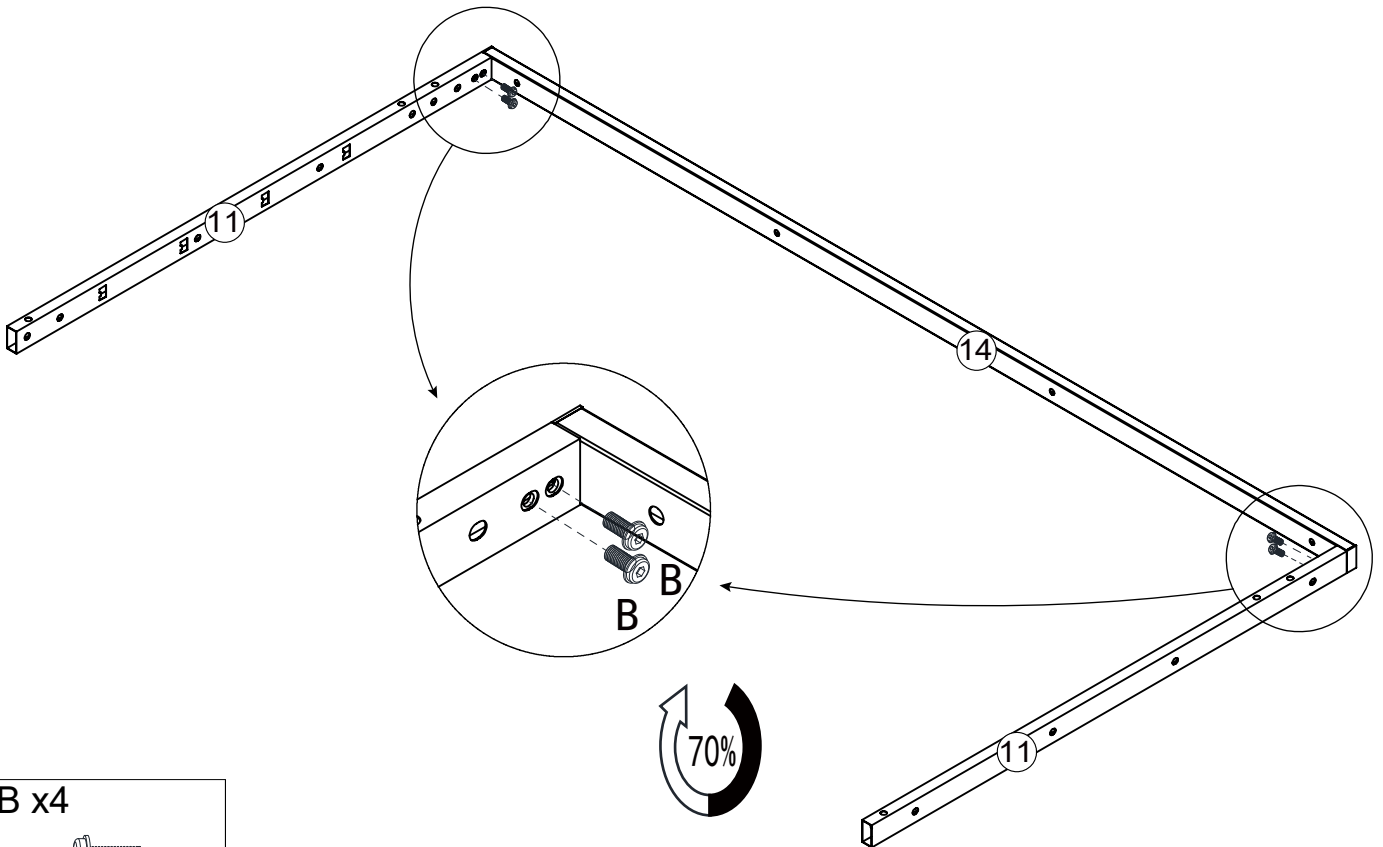

2

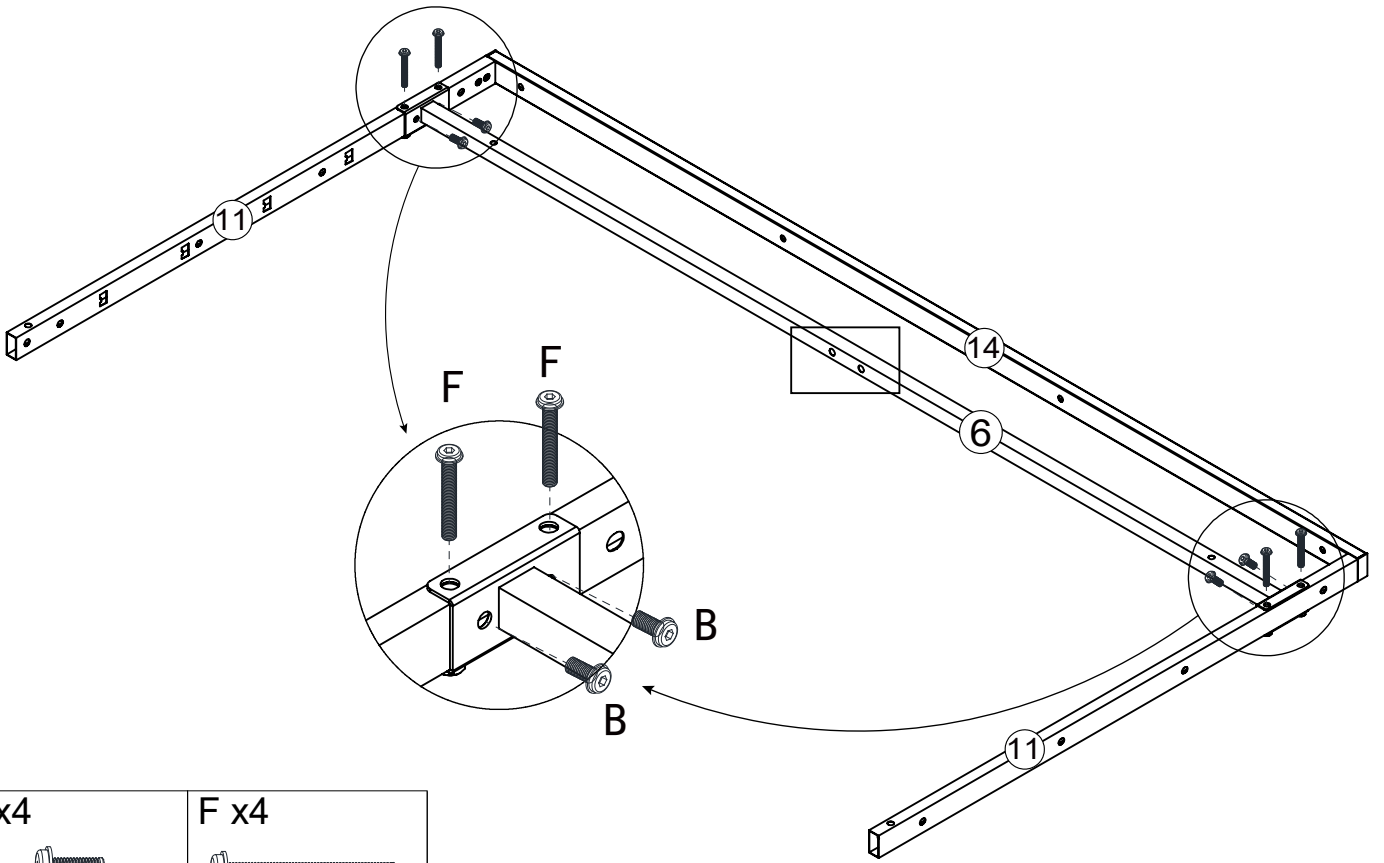

B x4

M8X14



3

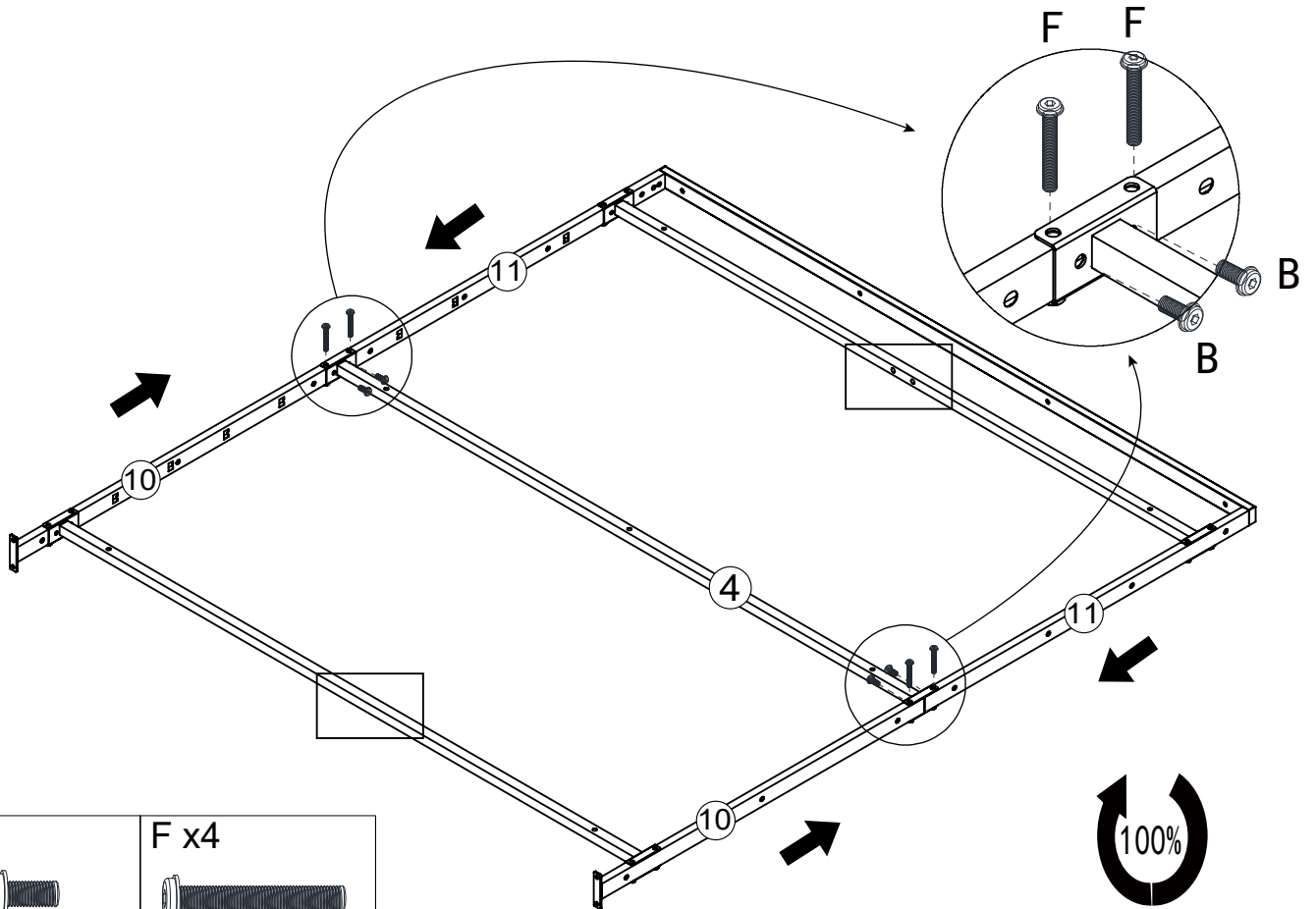

B x4	F x4
	
M8X14	M8X60

4



B x4	F x4
	
M8X14	M8X60

5

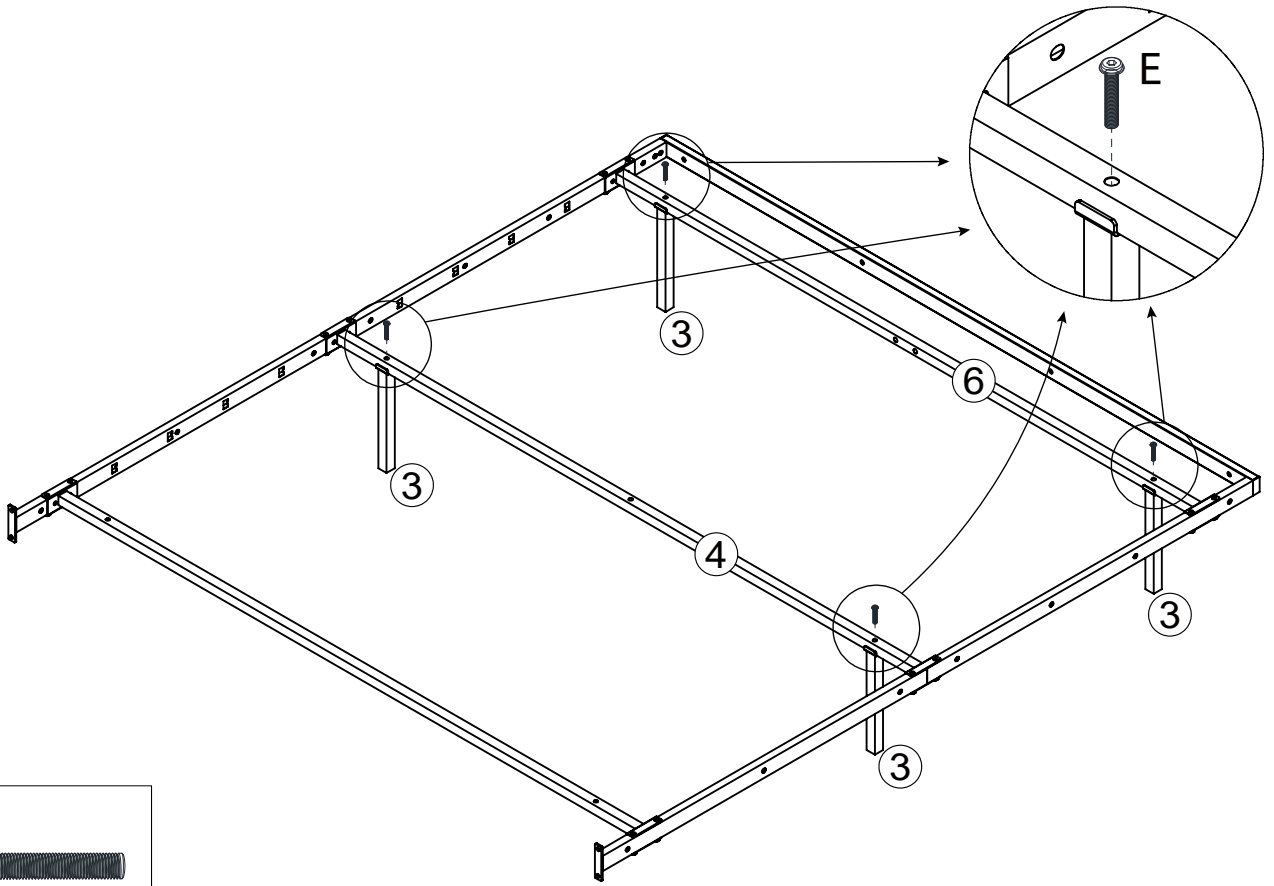

E x4



M8X40

6

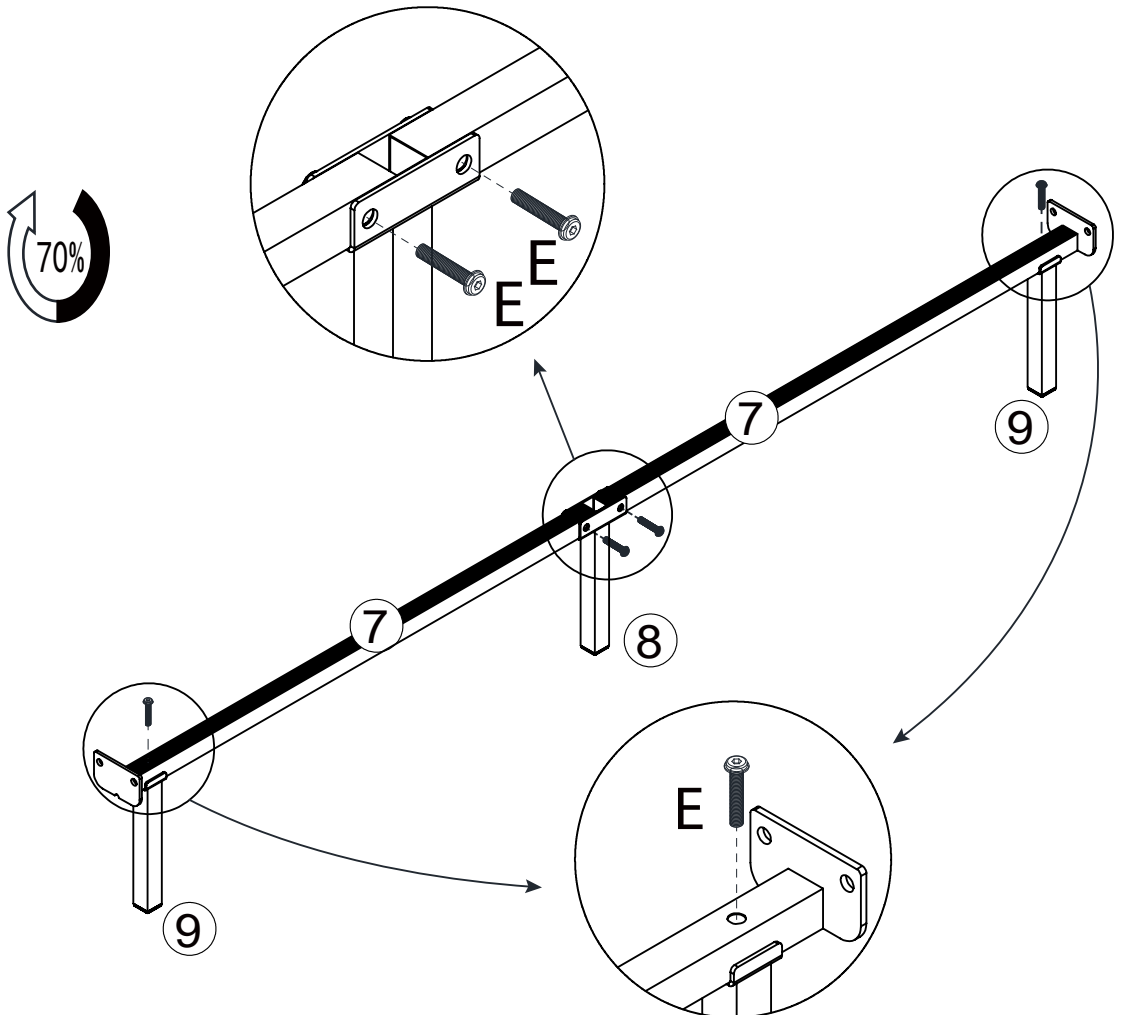

E x4



M8X40

7

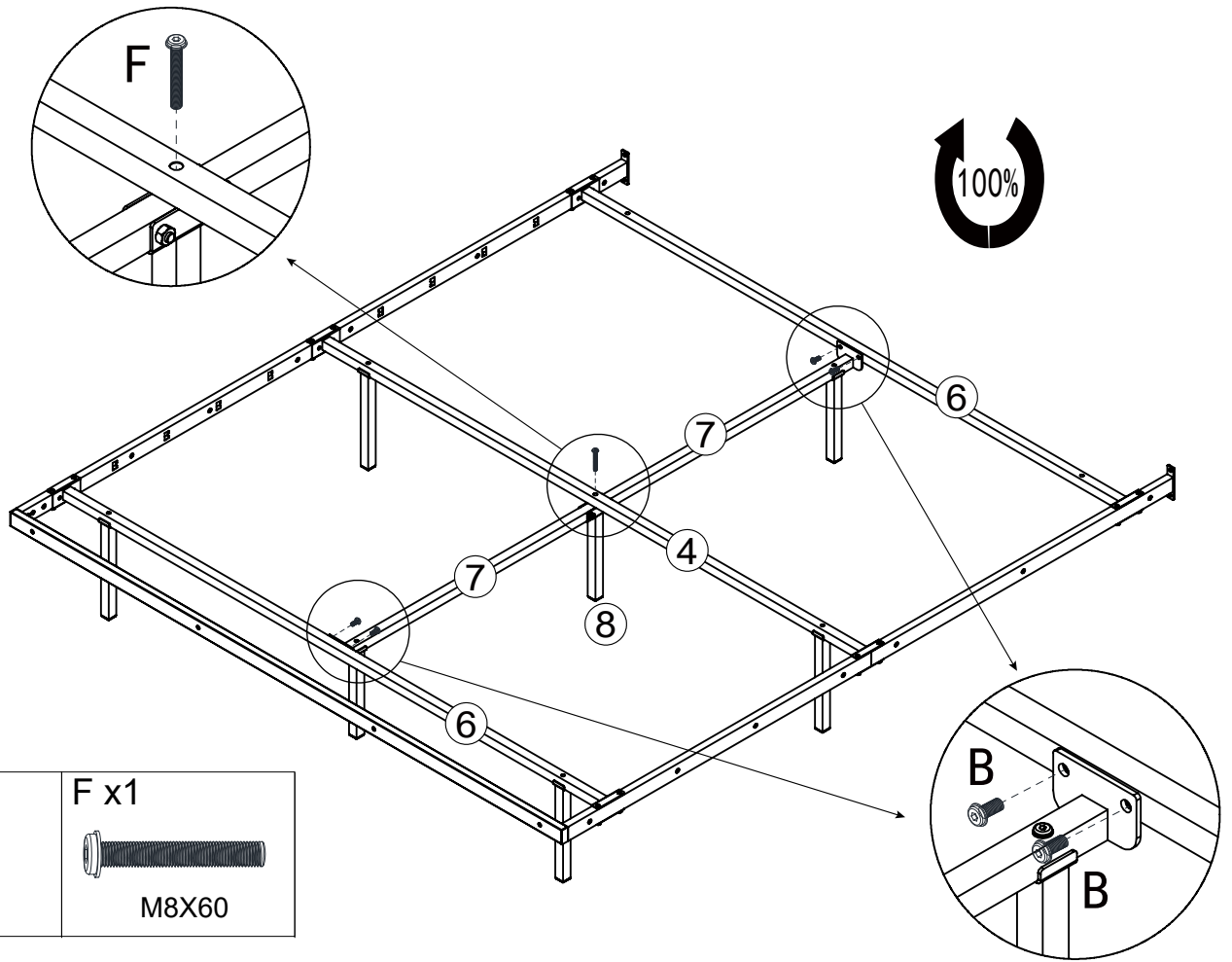

8

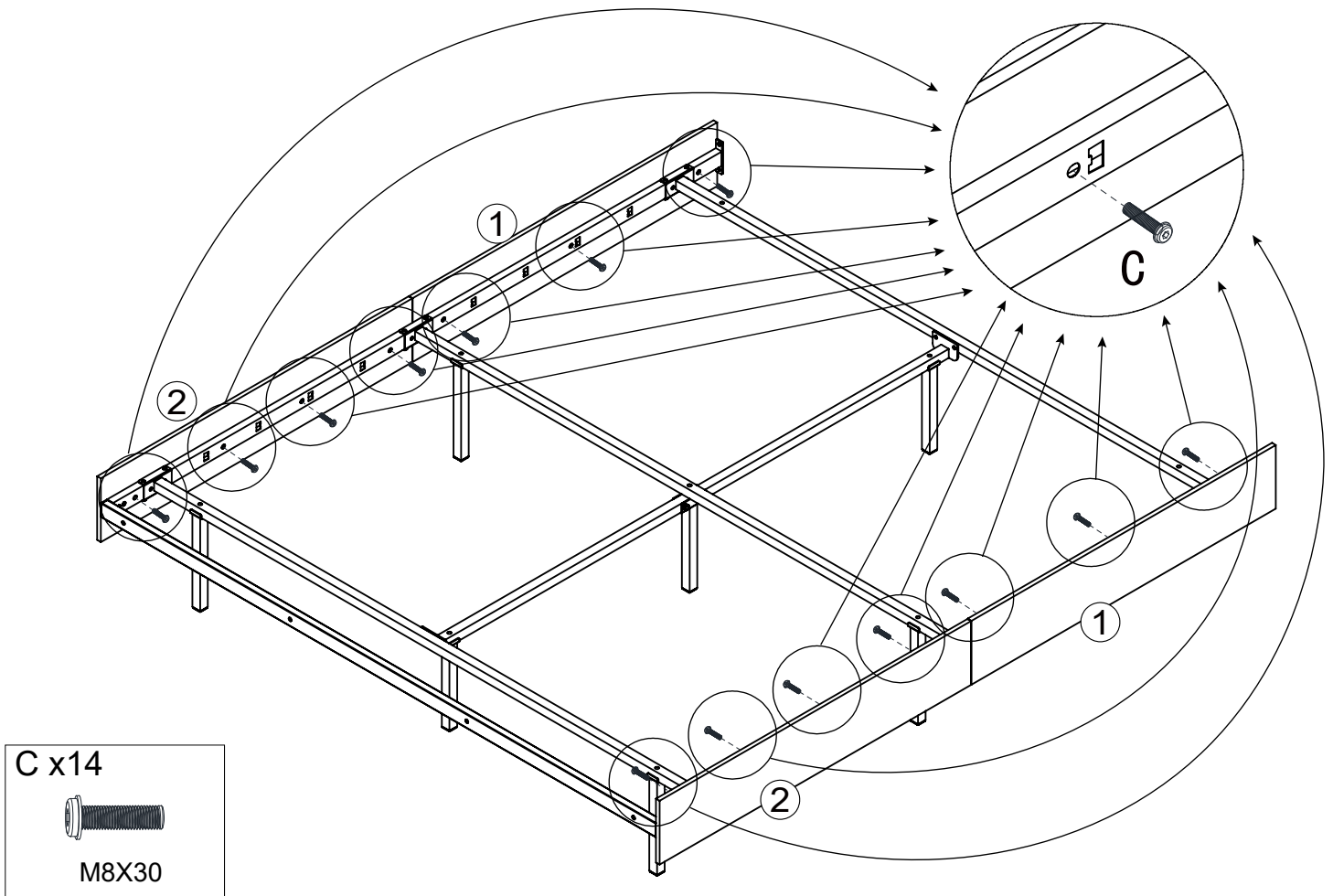

9

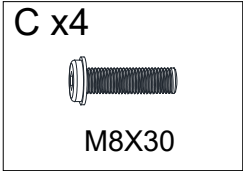
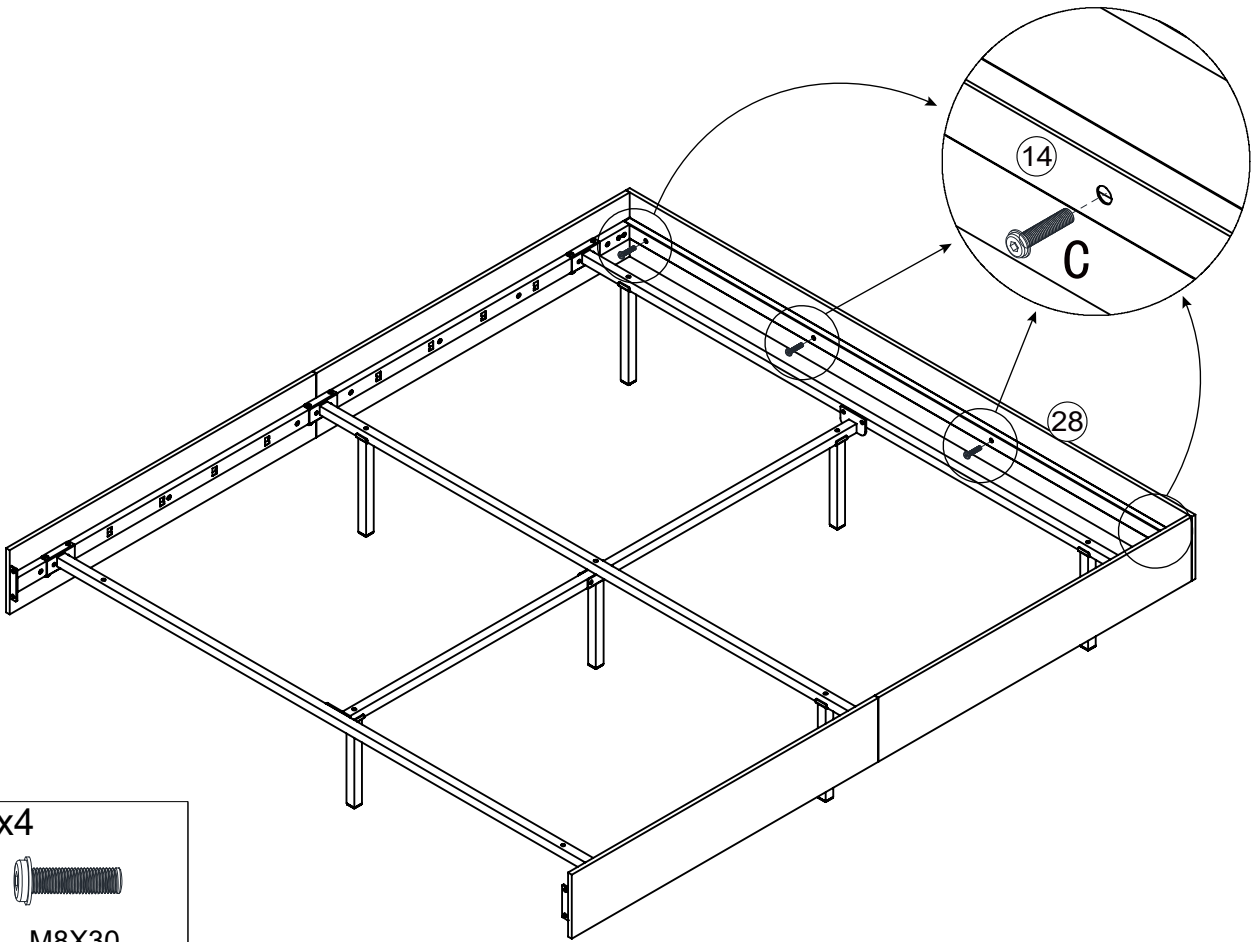

10

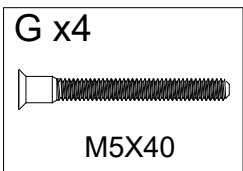
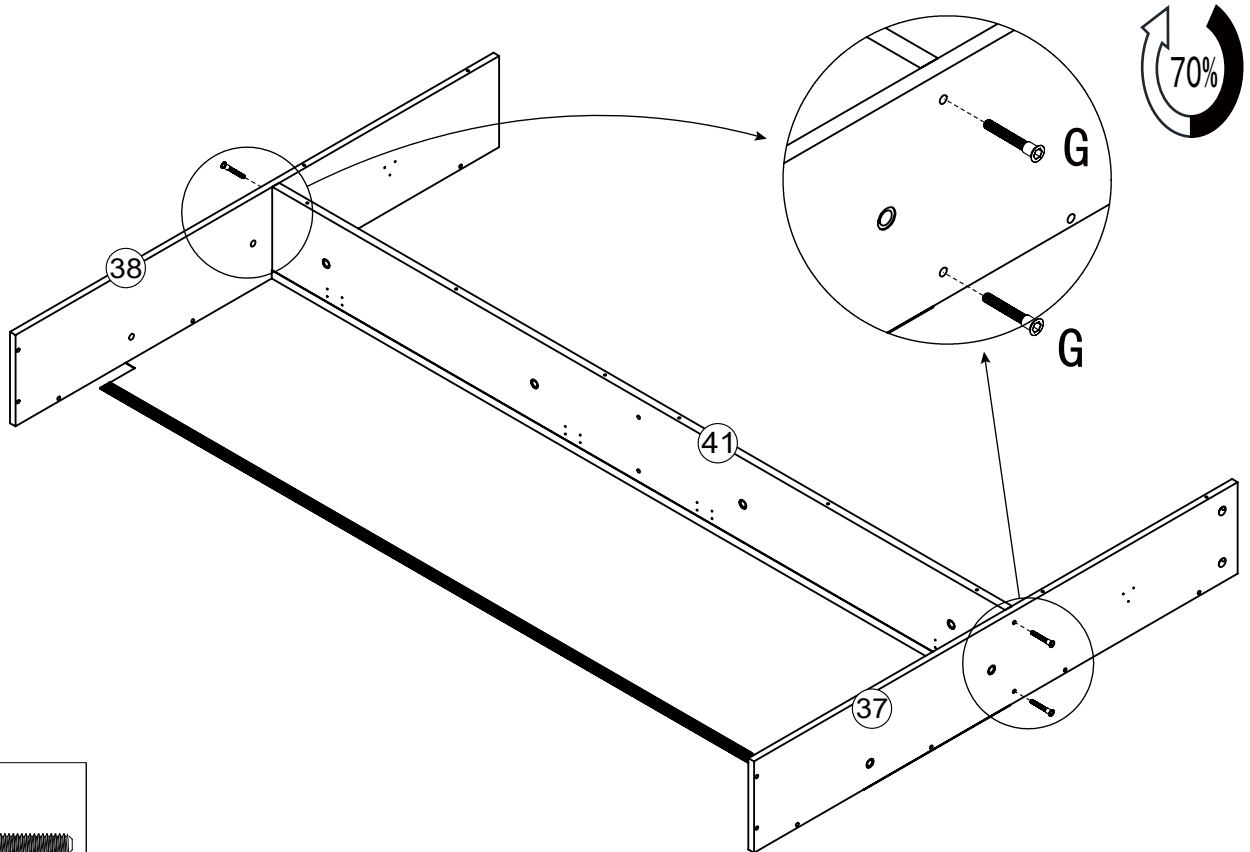

11

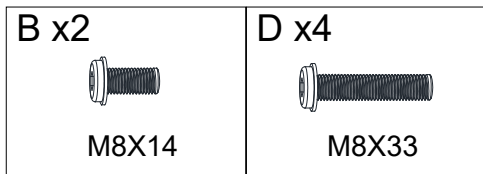
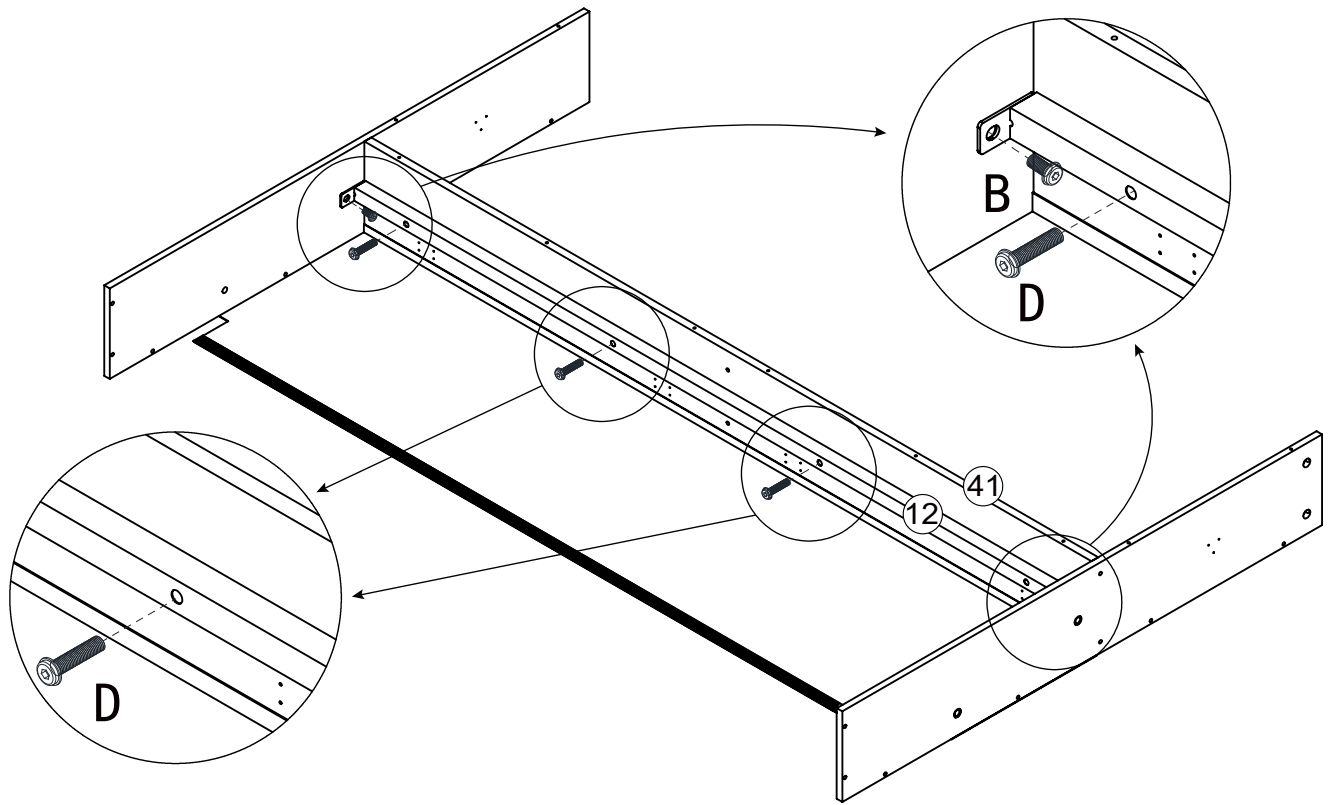

12

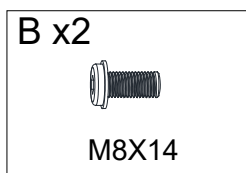
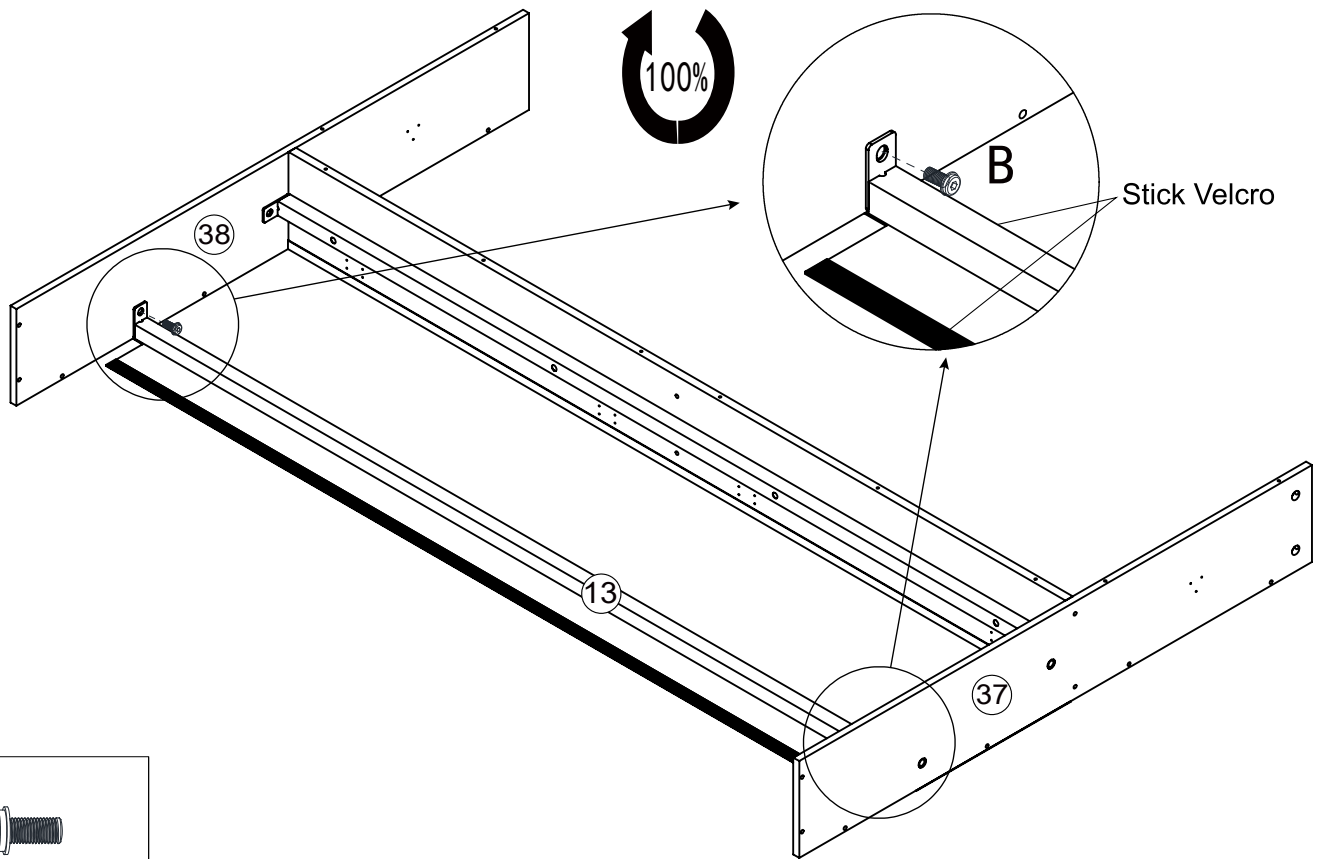

13

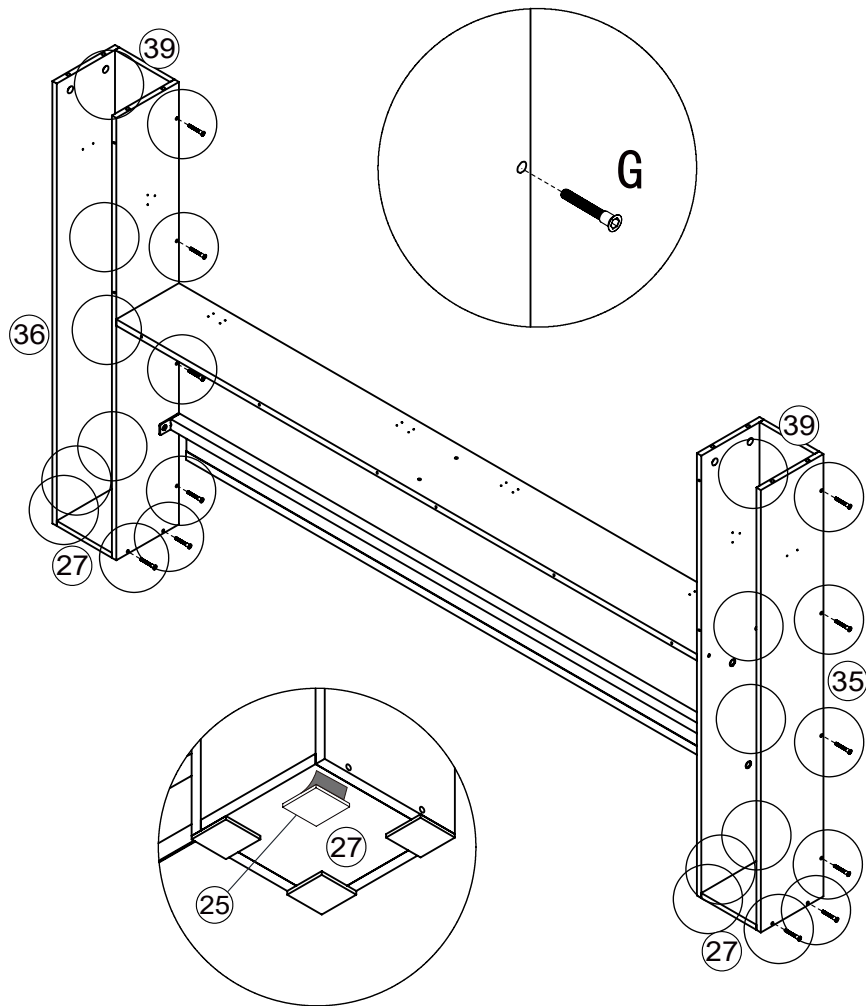

G x24



M5X40

14

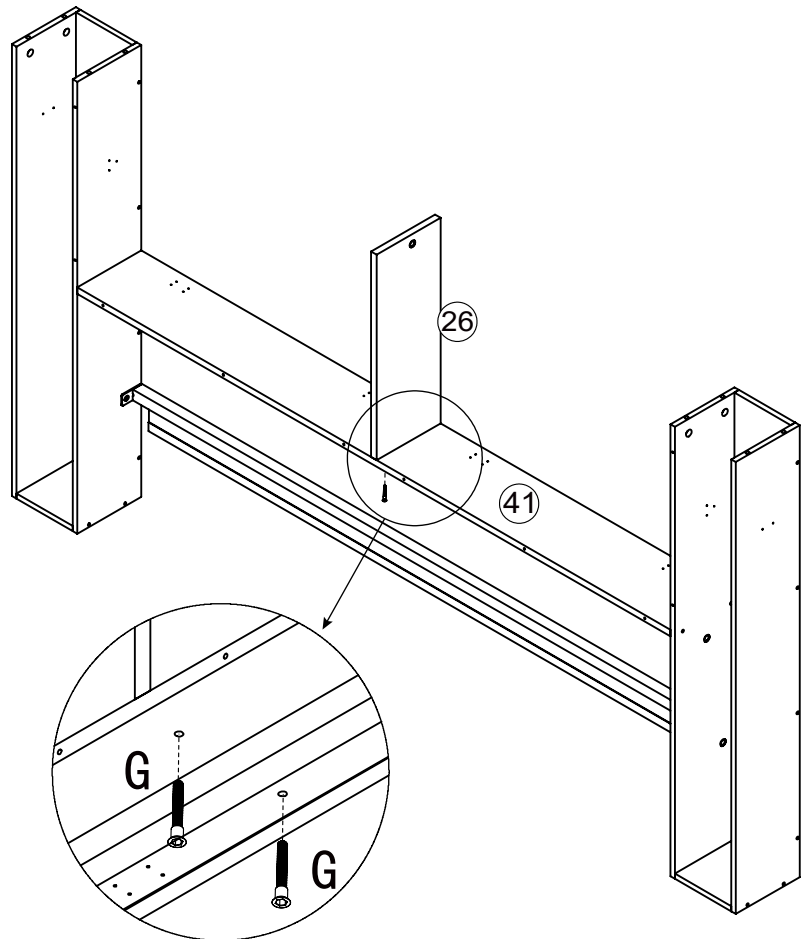

G x2



M5X40

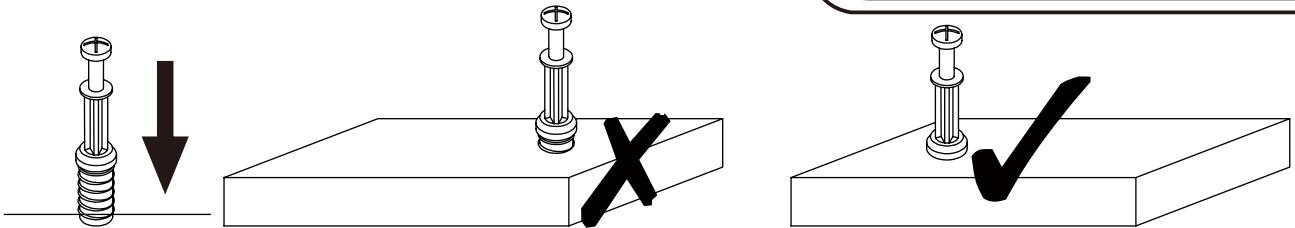

EN_QUICKFIT: Tighten quickfit until shoulder is flush with panel. Do not overtighten or undertighten.

FR_RACCORD RAPIDE: Faites serrer le raccord rapide jusqu'à ce que l'épaulement soit parfaitement encastré dans le panneau. Il ne faut ni trop serrer ni insuffisamment serrer.

ES_QUICKFIT: Apriete quickfit hasta que el hombro se descargue con el panel. NO lo sobreapriete ni lo apriete poco.

DE_QUICKFIT: Ziehen Sie den Quickfit fest, bis die Schulter mit der Platte bündig ist. Bitte nicht zu fest oder zu schwach anziehen.

IT_MONTAGGIO RAPIDO: Stringere il montaggio rapido fino a quando la spalla è a filo con il pannello, non stringere troppo o troppo poco.

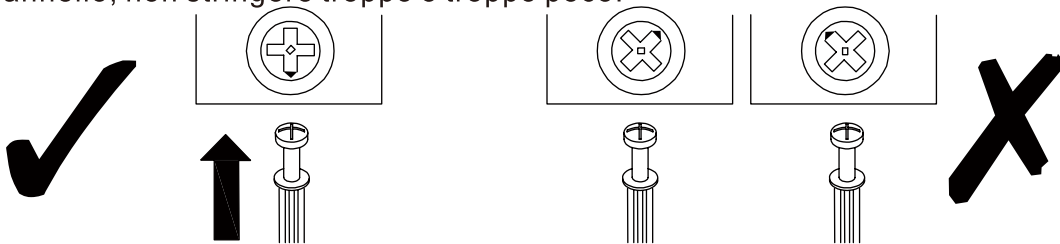

EN_CAM LOCK: When fitting cam lock, ensure starting position is correct before you insert connecting quickfit.

FR_SERRURE BATTEUSE: Avant d'insérer la serrure batteuse, veillez à la bonne orientation avant d'insérer le raccord rapide.

ES_CIERRE DE LA CÁMARA: Cuando instale el cierre de la cámara, asegúrese de que la posición de inicio es correcta antes de que inserte el quickfit conector.

DE_CAM-LOCK: Achten Sie bei der Montage des Cam-Locks auf die richtige Ausgangsposition, bevor Sie den Quickfit einsetzen.

IT_BLOCCAGGIO A CAMMA: Quando si monta il bloccaggio a camma, assicurarsi che la posizione iniziale sia corretta prima di inserire il montaggio rapido di collegamento.

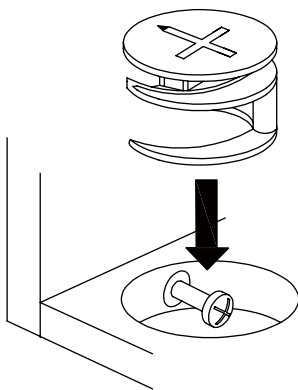

EN_Quickfit head should be in the centre of the cam lock when the two panels are joined.

Cam lock should be inserted before quickfit.

FR_Lorsque les deux panneaux sont assemblés, la tête du raccord rapide doit reposer au centre de la serrure batteuse. Il faut insérer la serrure batteuse avant le raccord rapide.

ES_El cabezal del quickfit debe estar en el centro del cierre de la cámara cuando se unan los dos paneles.

Se debe insertar el cierre de la cámara antes que el quickfit.

DE_Der Quickfit-Kopf sollte sich in der Mitte des Cam-Locks befinden, wenn die beiden Platten zusammengefügt sind.

Der Cam-Lock sollte vor dem Quickfit eingesetzt werden.

IT_La testa del montaggio rapido deve trovarsi al centro del bloccaggio a camma quando i due pannelli sono uniti.

Il Bloccaggio a Camma deve essere inserito prima del montaggio rapido.

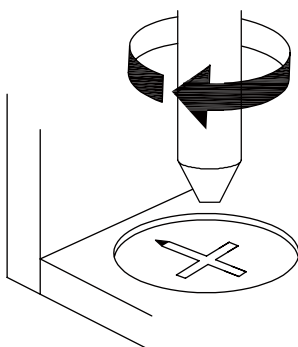

EN_Turn cam lock clockwise to tighten.

FR_Faites tourner la serrure batteuse dans le sens des aiguilles d'une montre pour la resserrer.

ES_Gire el cierre de la cámara en sentido horario para apretarlo.

DE_Drehen Sie den Cam-Lock im Uhrzeigersinn, um ihn festzuziehen.

IT_Ruotare il bloccaggio a camma in senso orario per stringere.

15

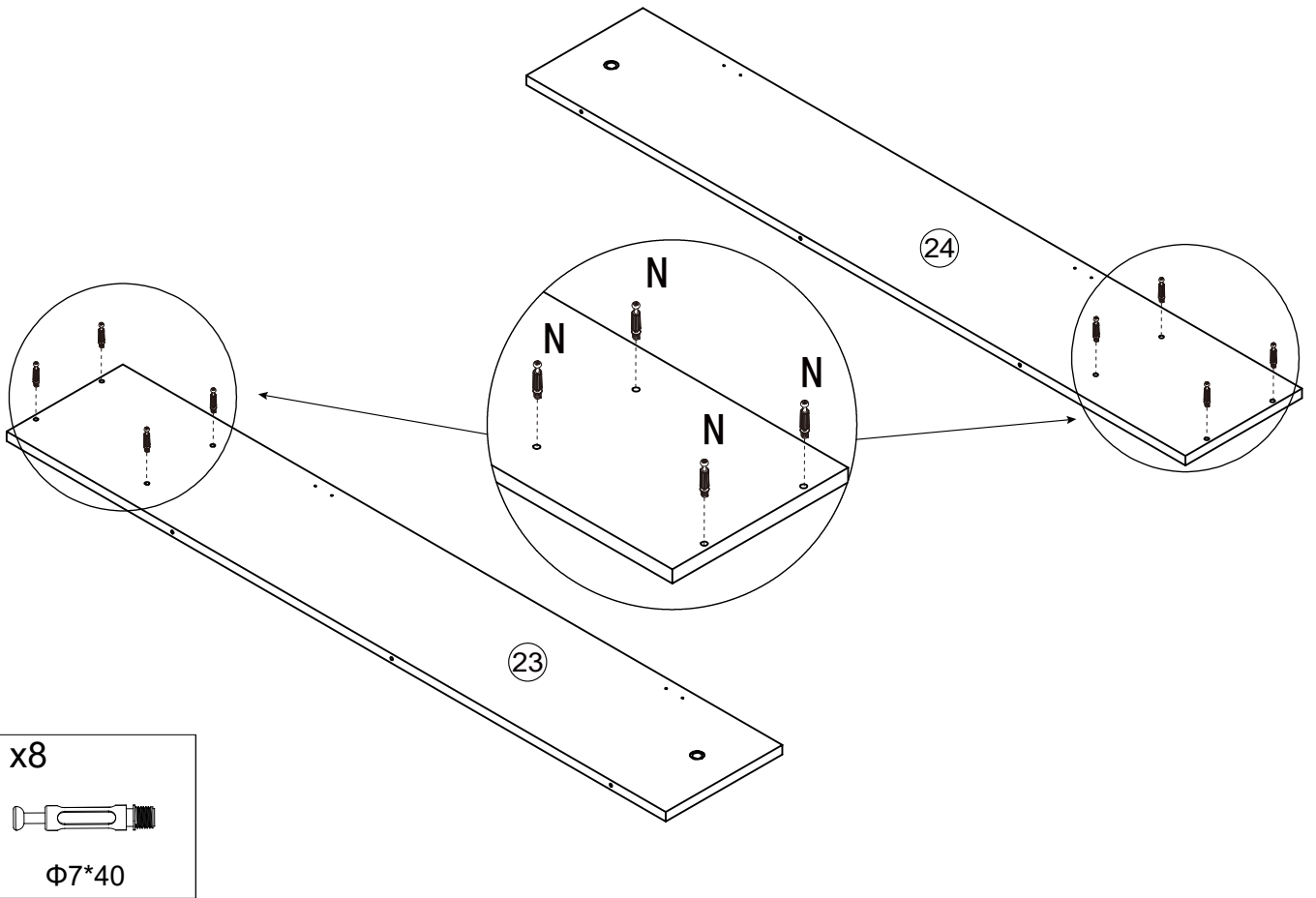

16

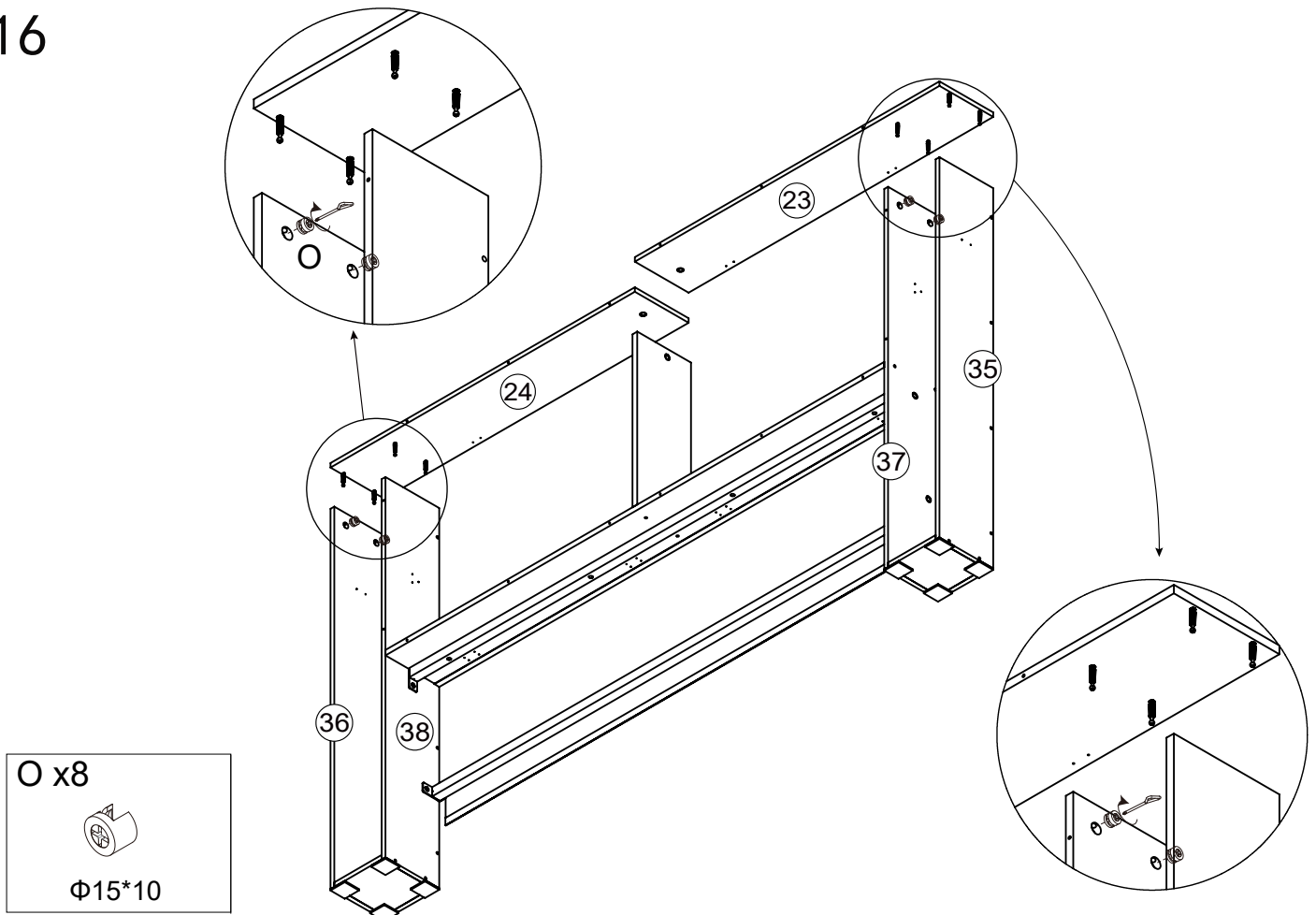

17

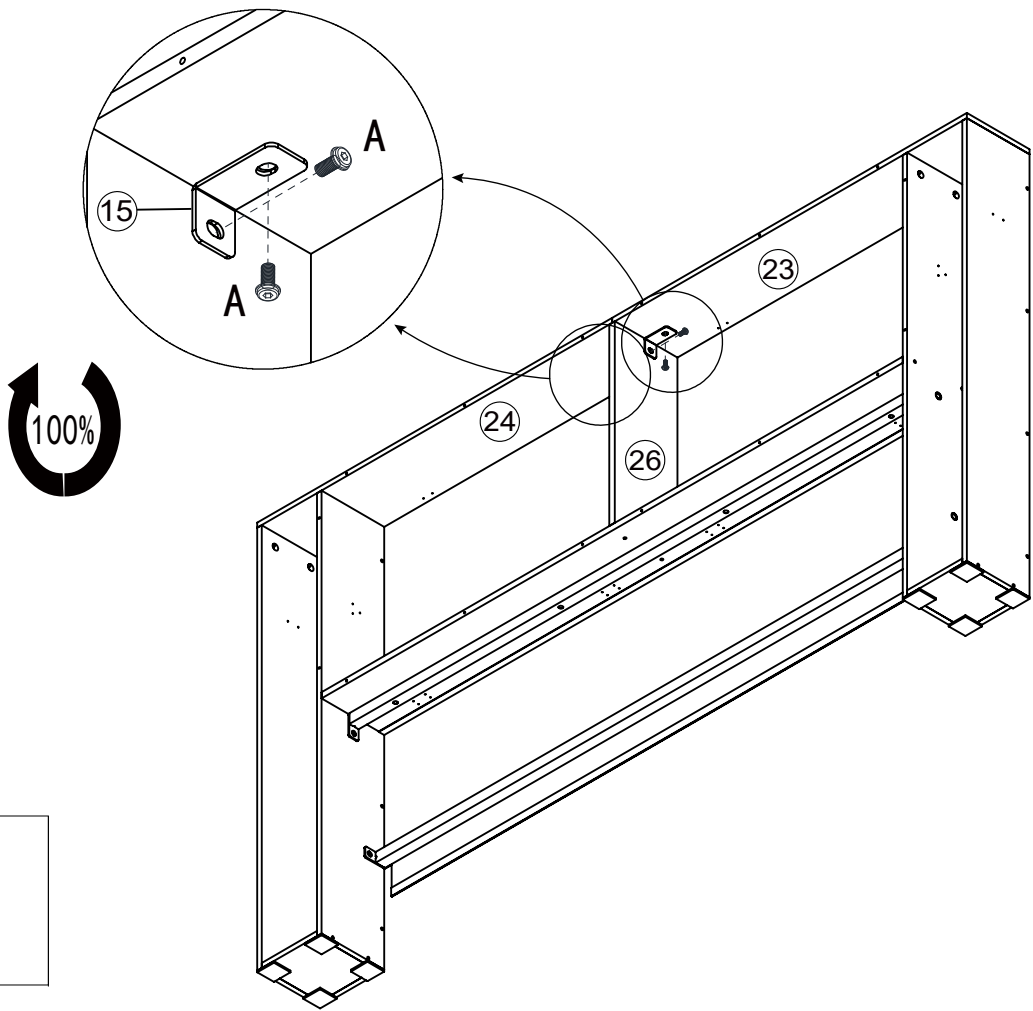

A x4



M8X12

18

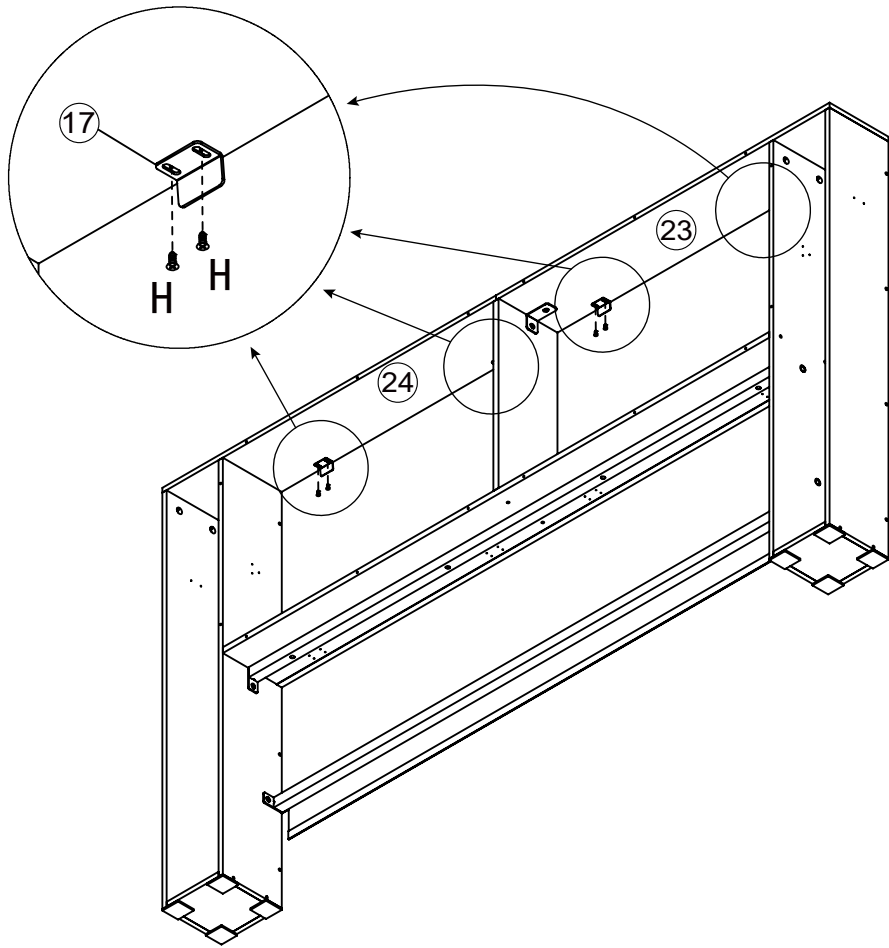

H x8



ST3.2X12

19

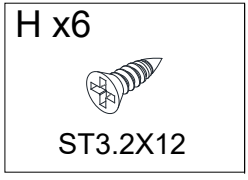
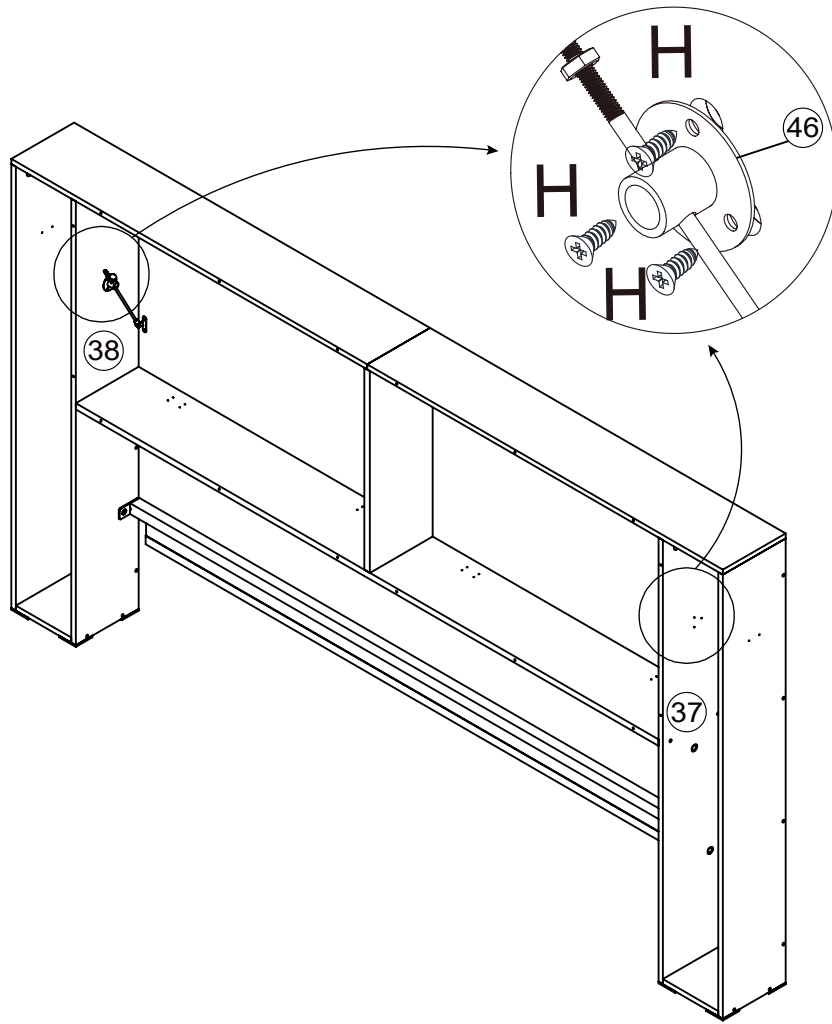

20

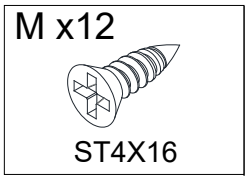
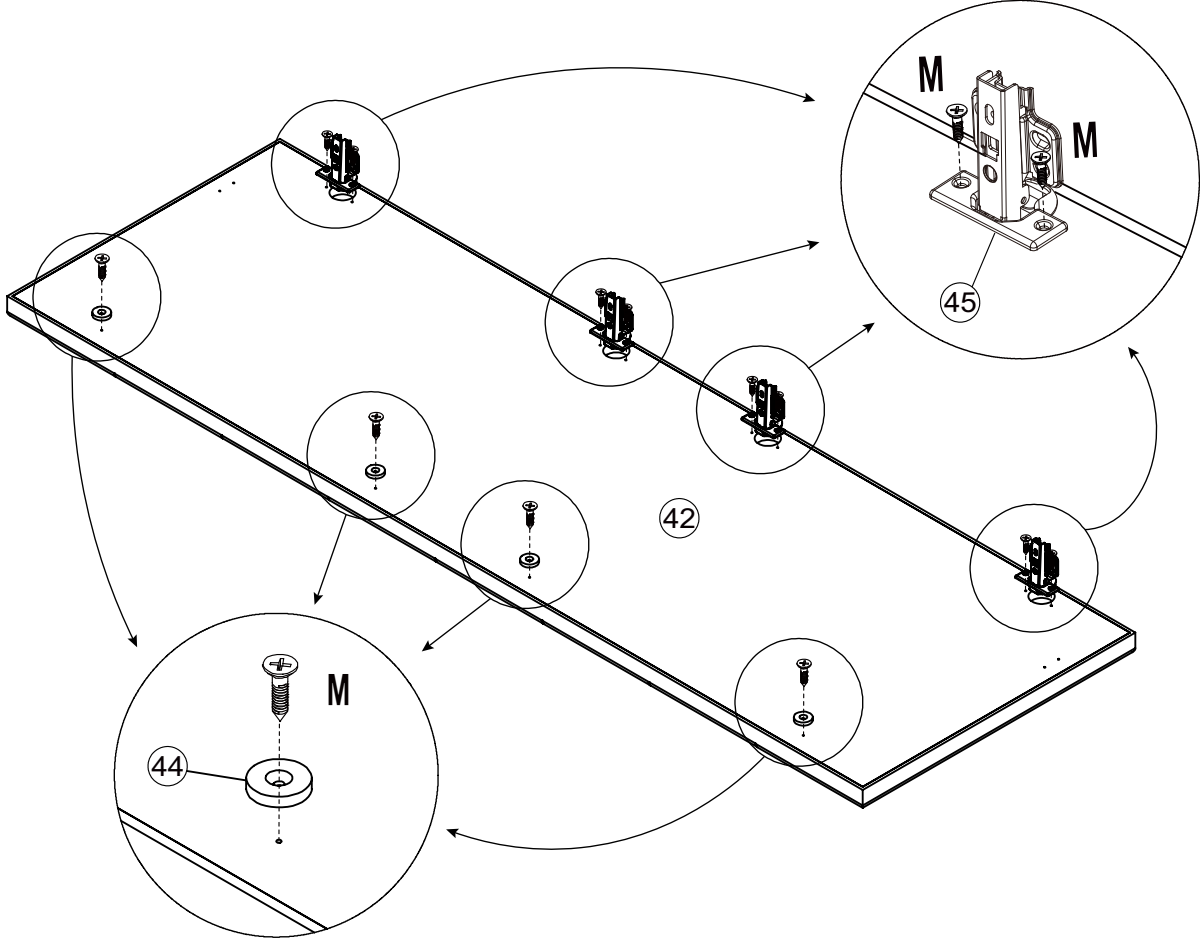

21

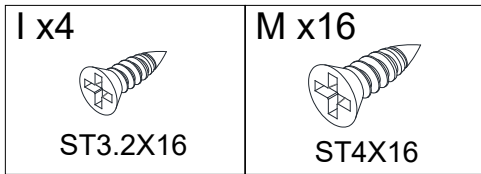
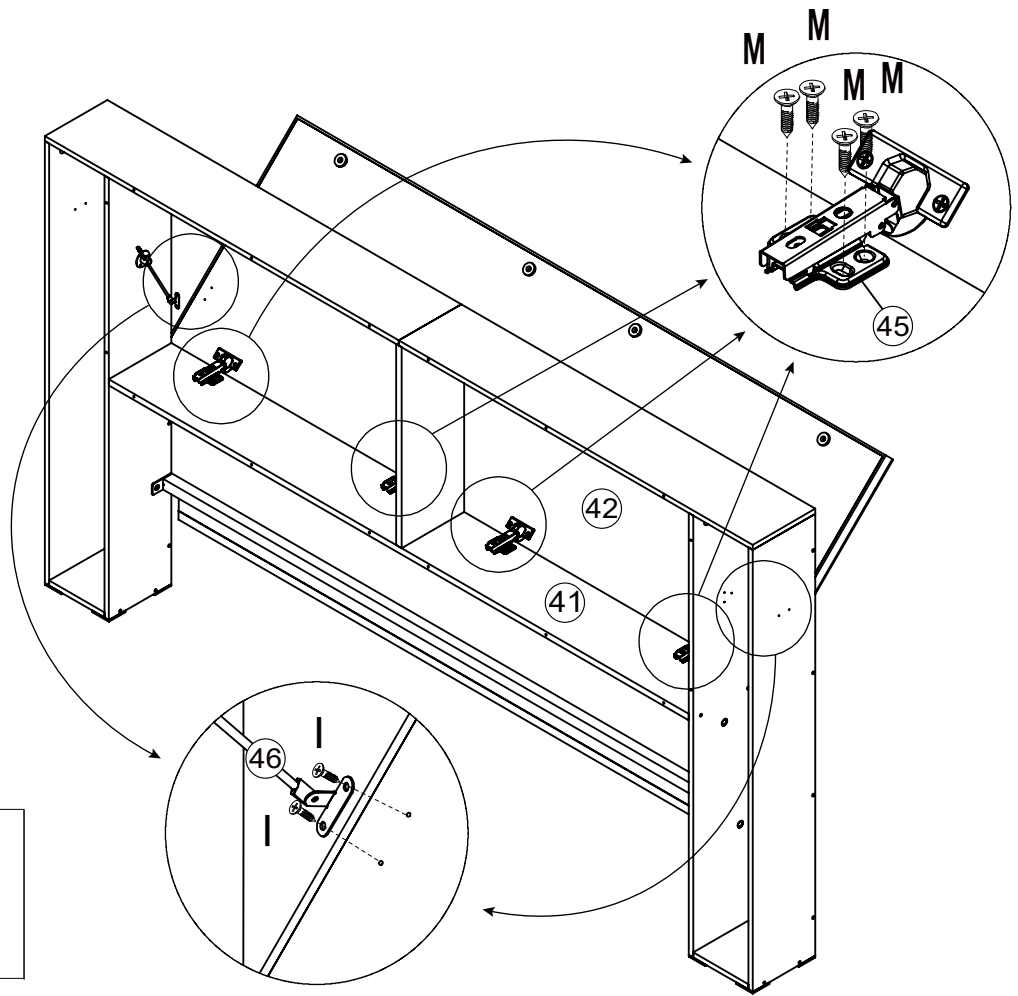
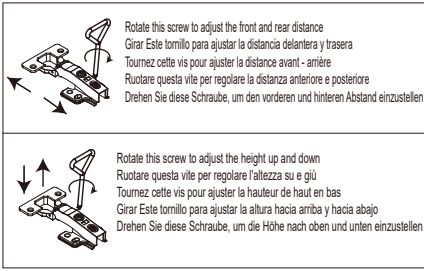

22

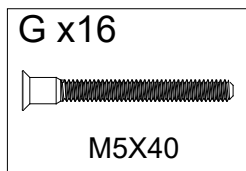
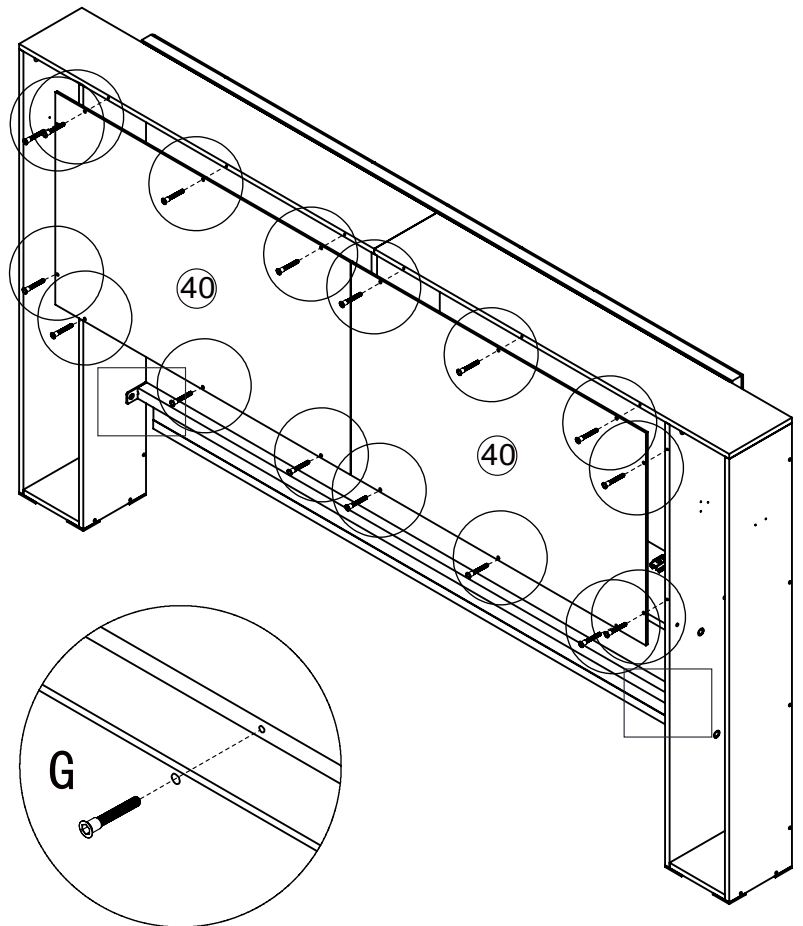
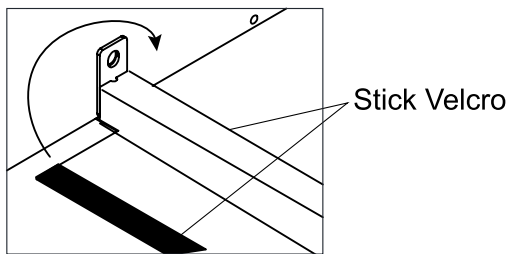

23

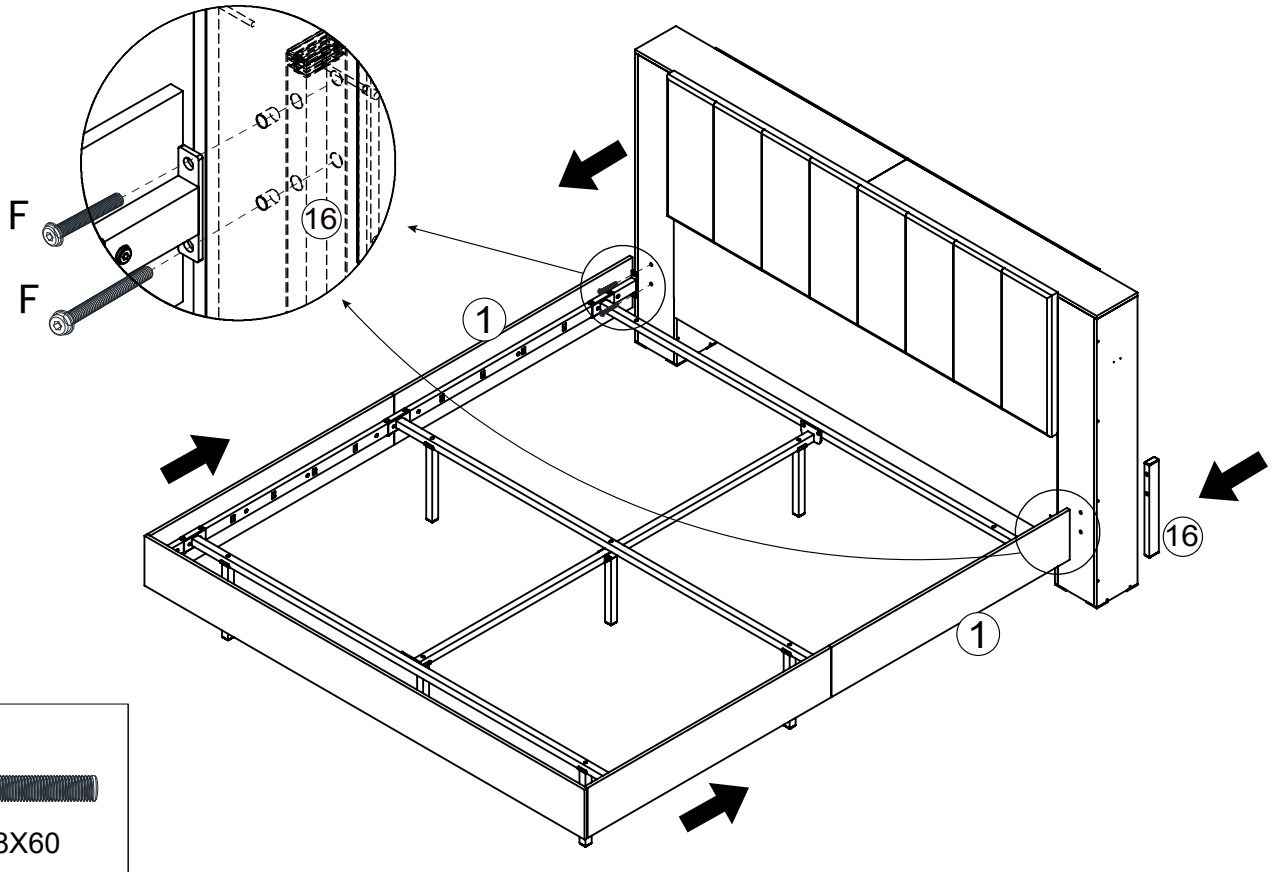

24

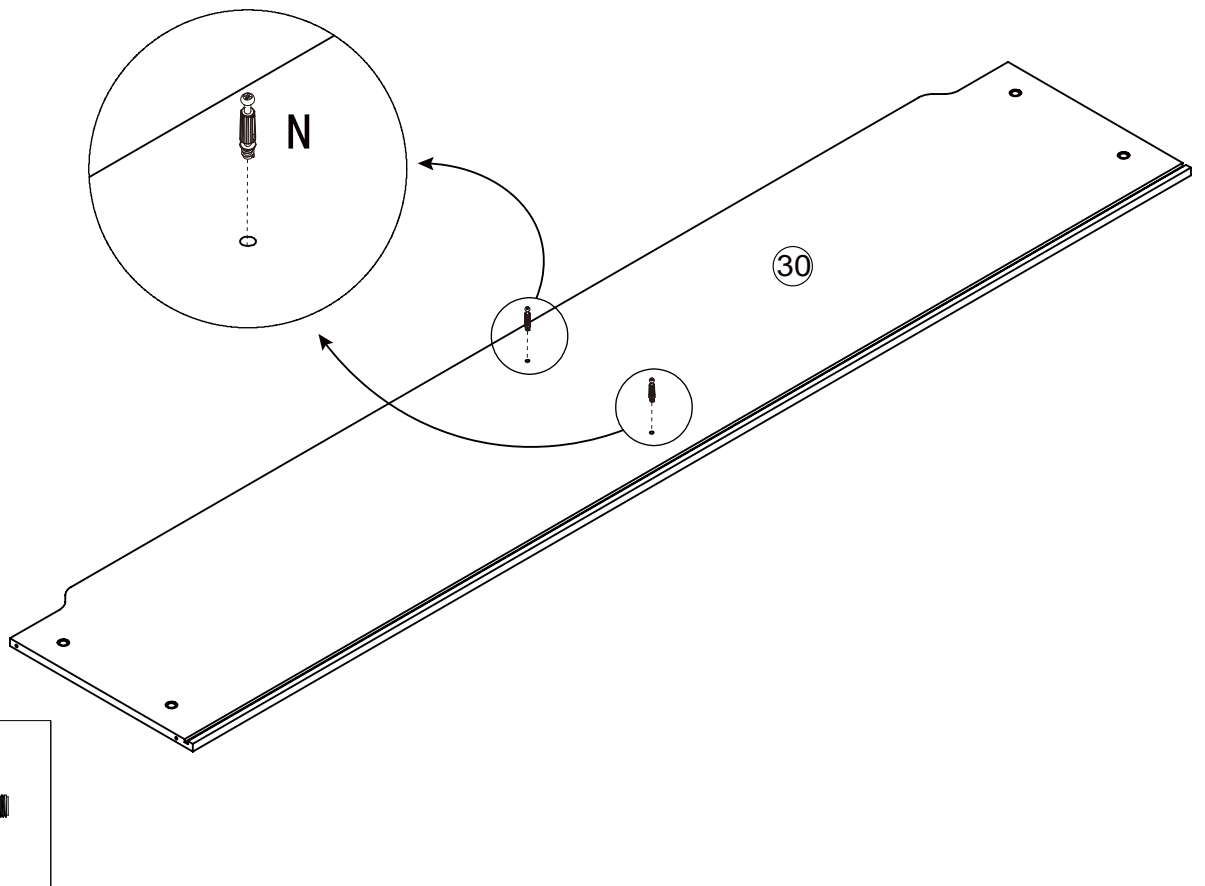

25

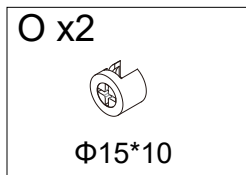
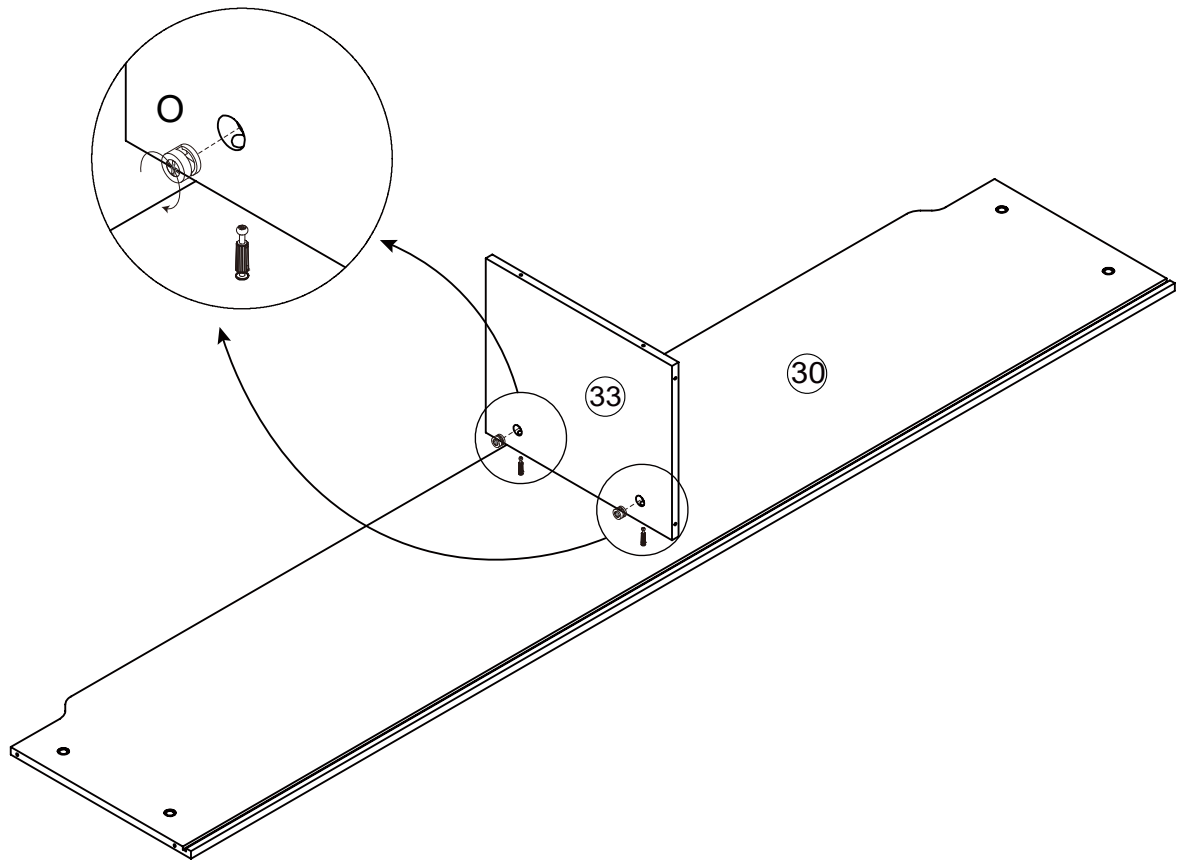

26

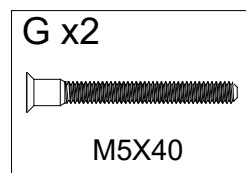
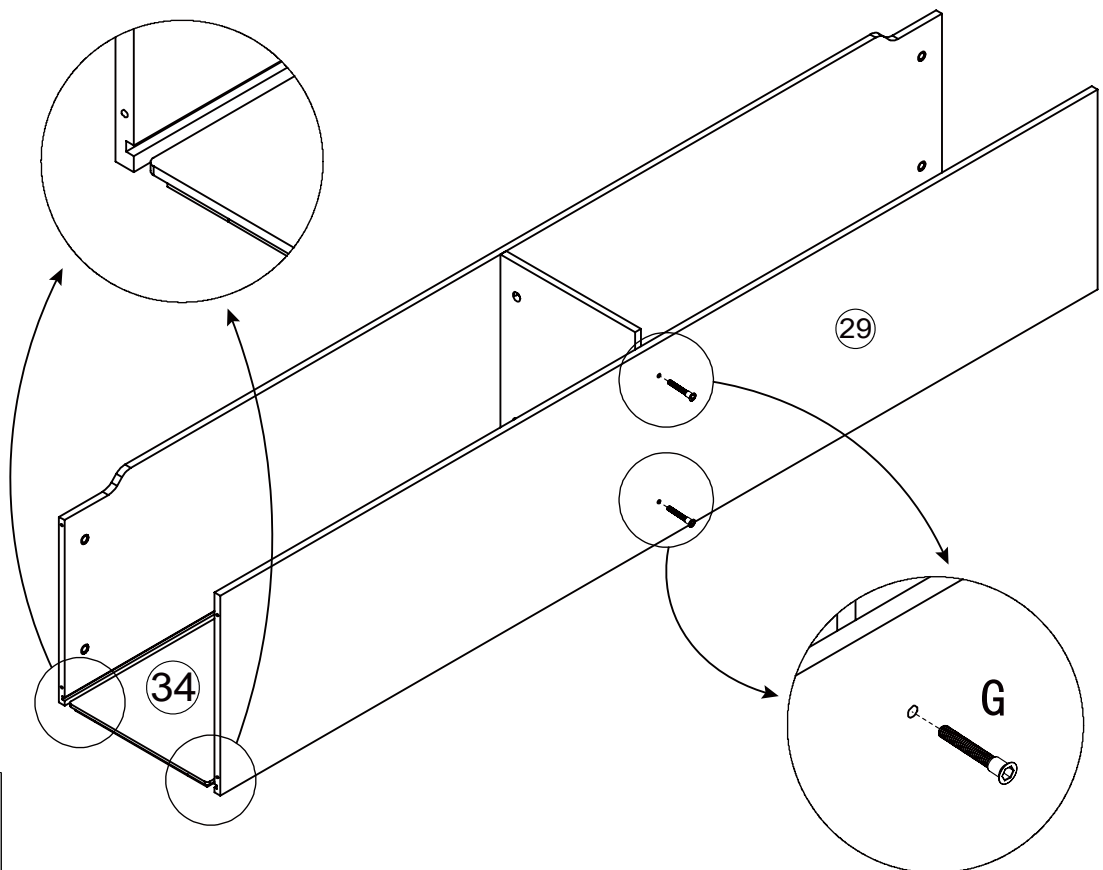

27

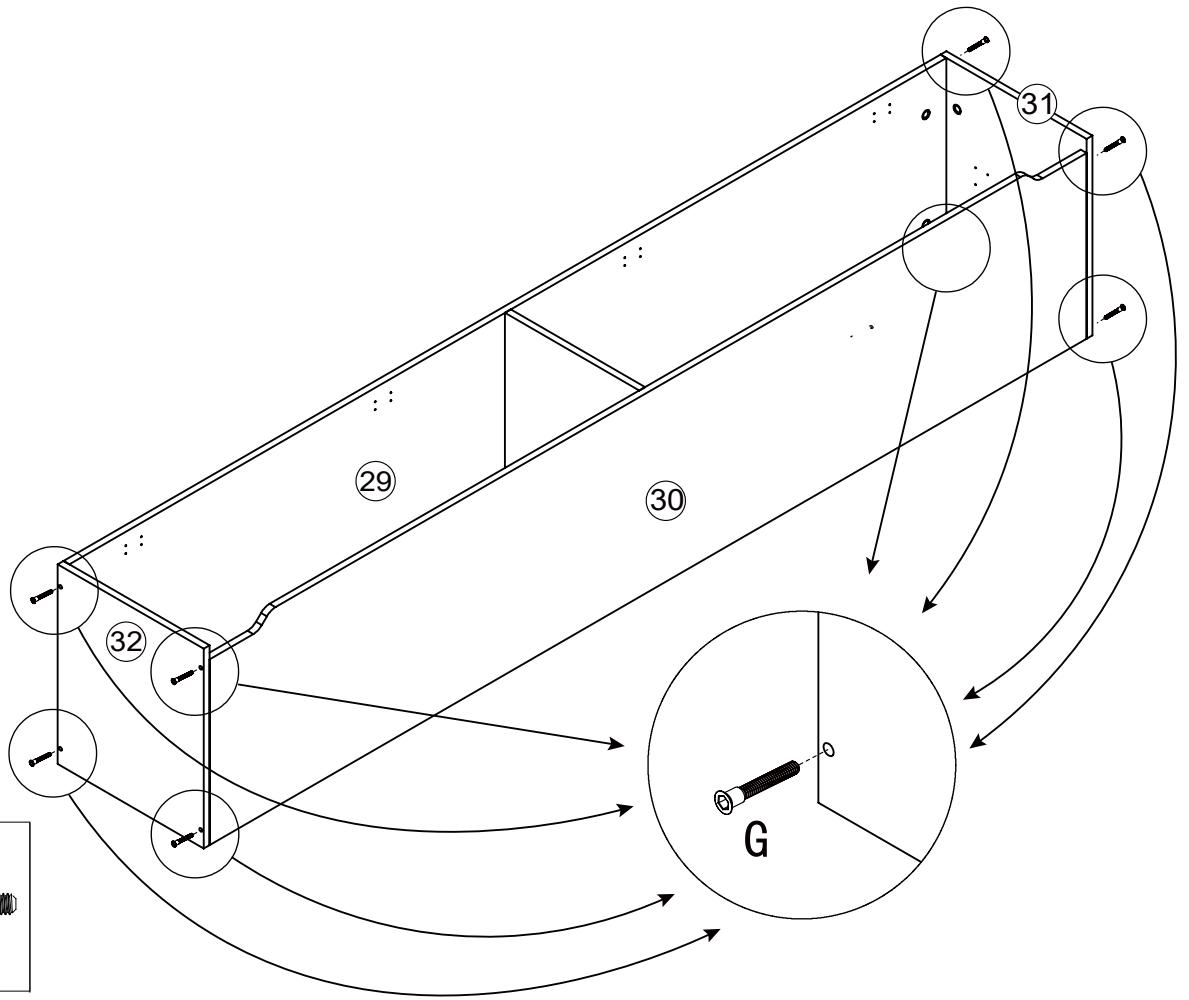

28

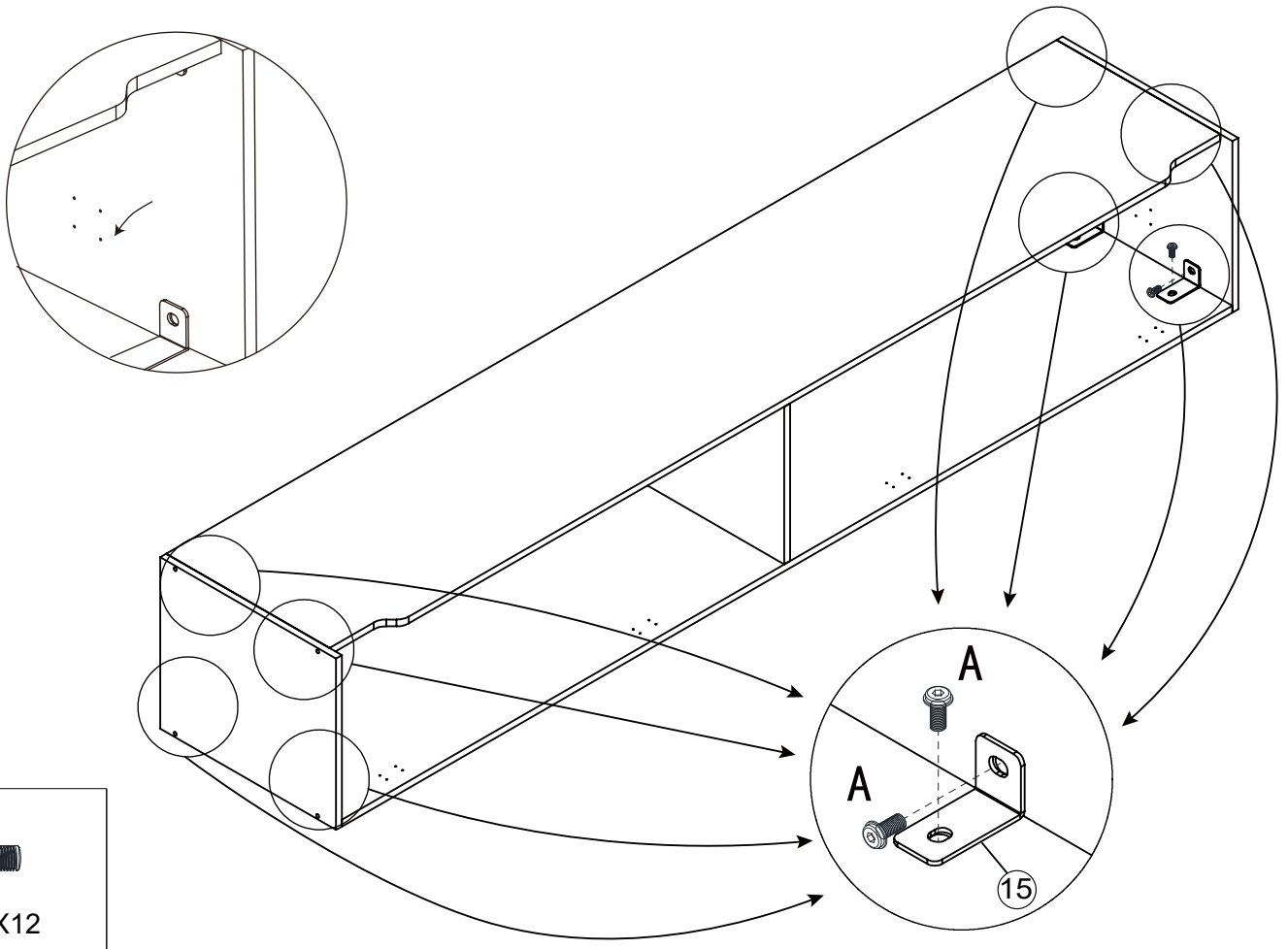

29

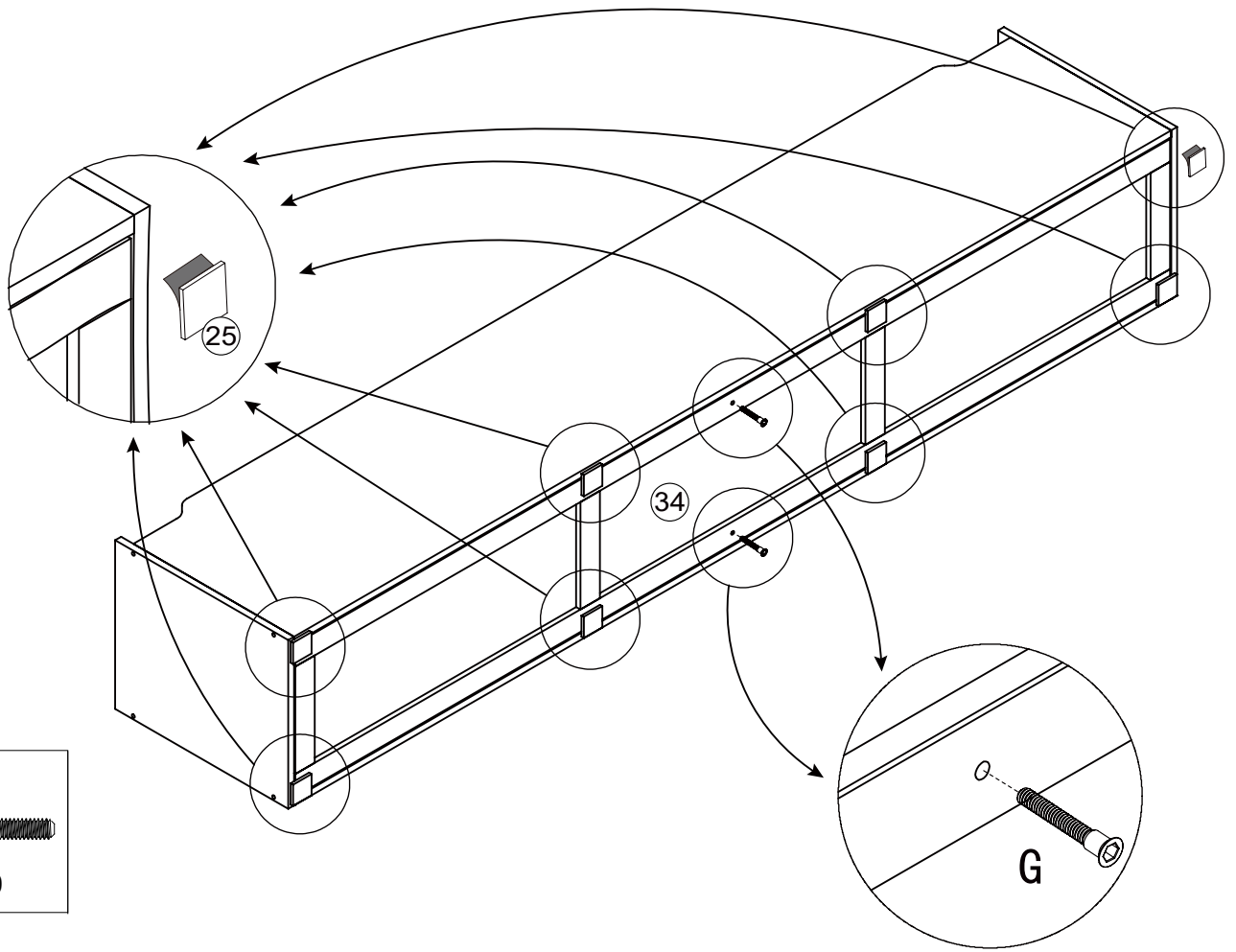

30
x2

Unscrewed Hardware
Ungeschraubte Hardware
Hardware svitato
Herrajes desatornillados
Quincaillerie non vissée

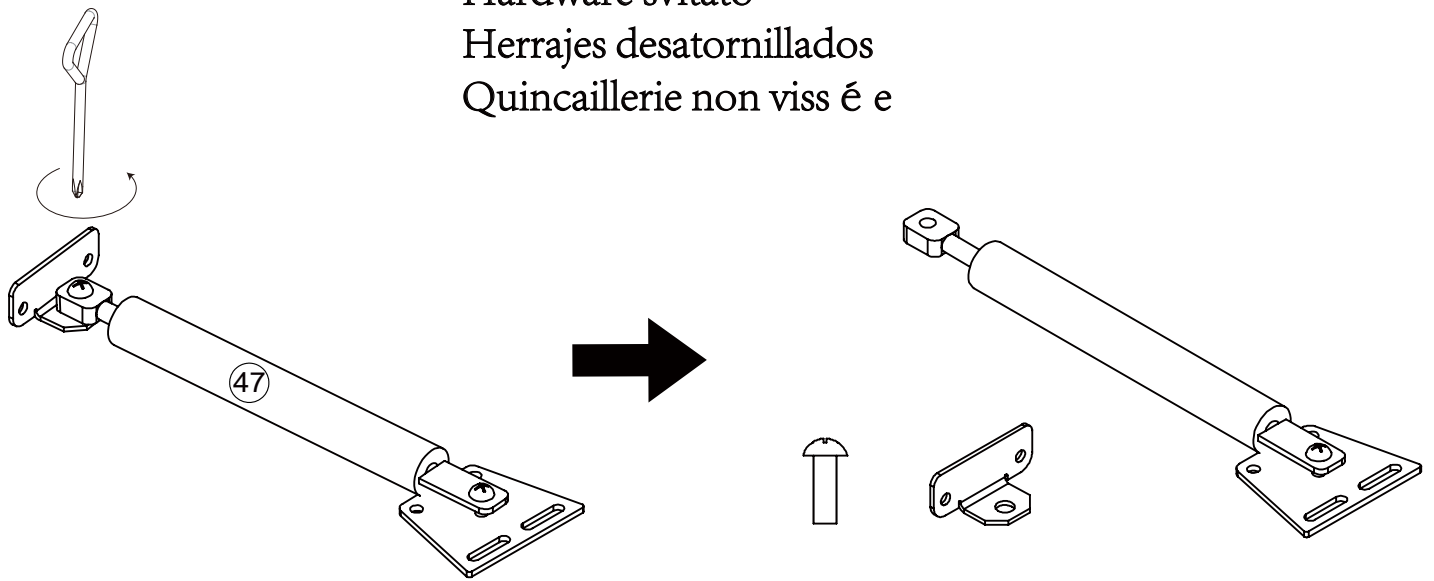

31

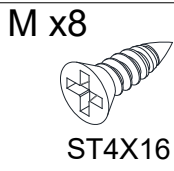
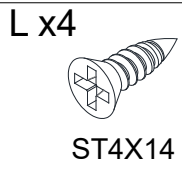
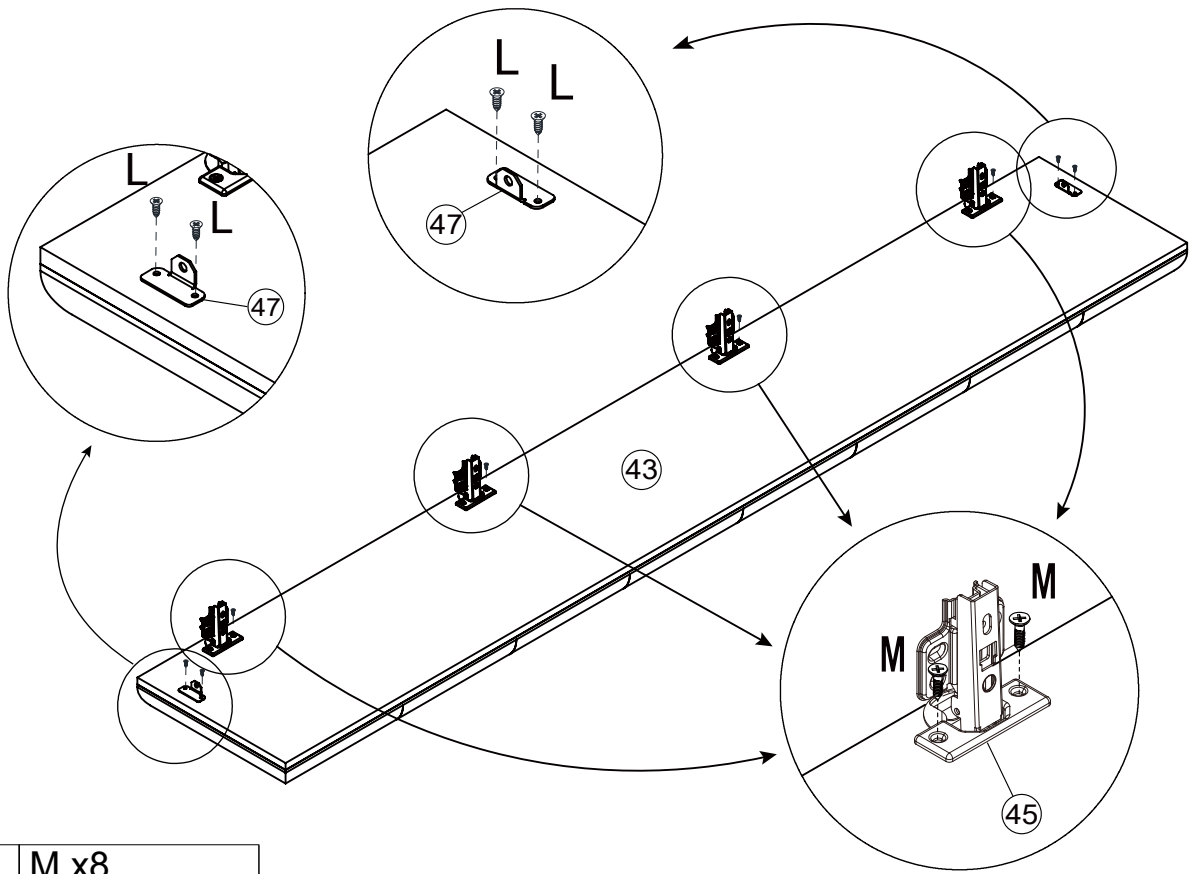

32

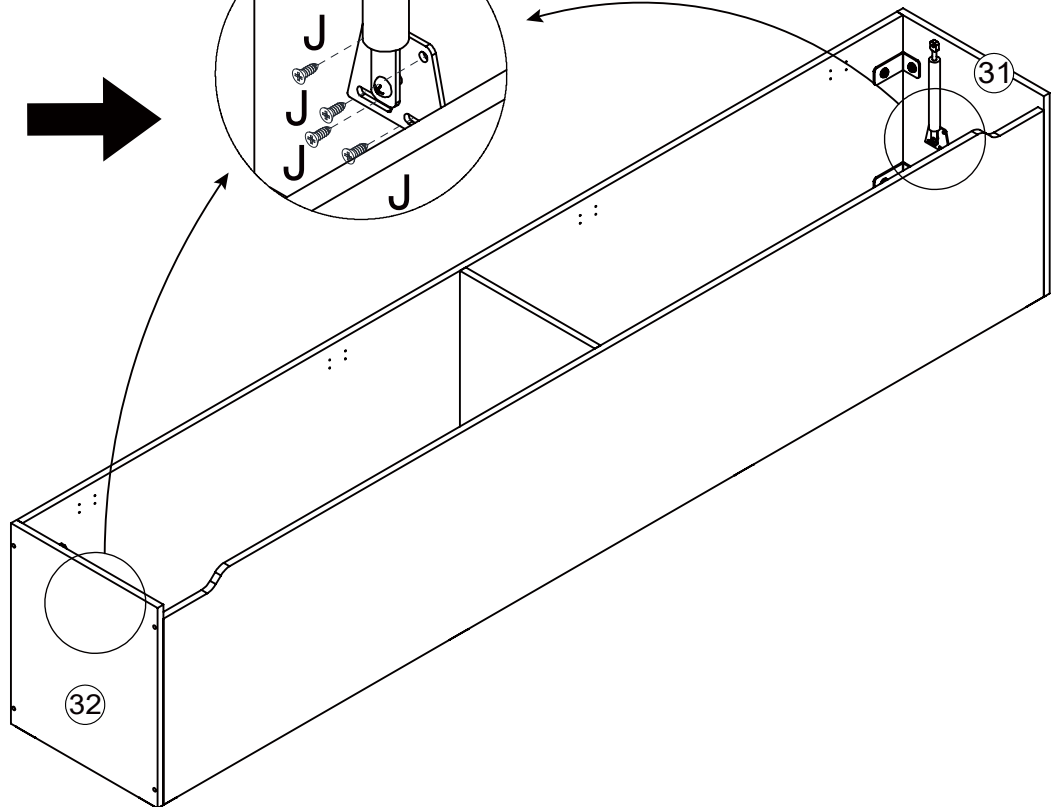
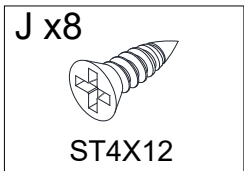
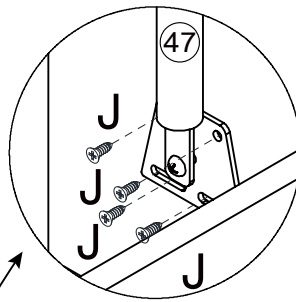
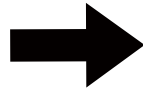
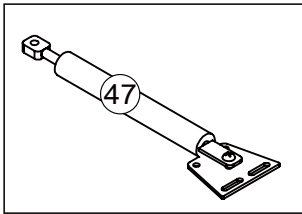

33

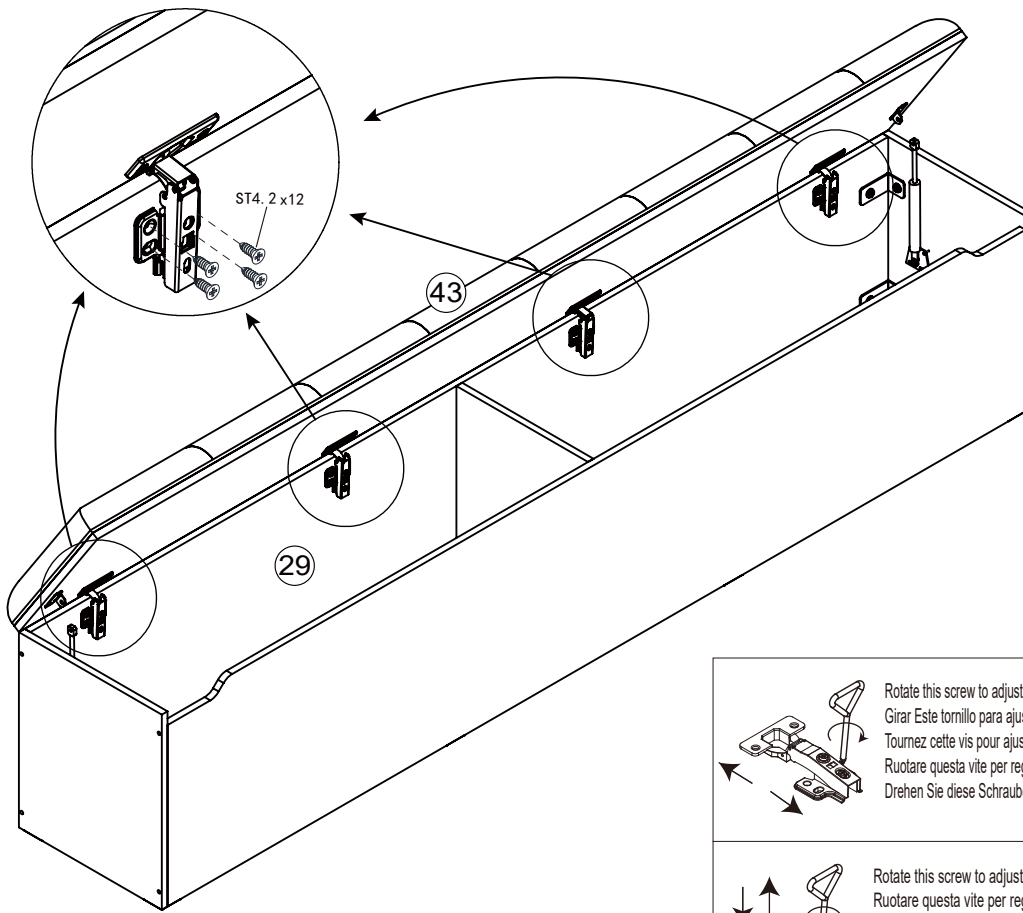

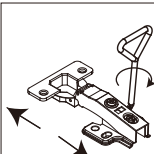
 Rotate this screw to adjust the front and rear distance
 Girar Este tornillo para ajustar la distancia delantera y trasera
 Tournez cette vis pour ajuster la distance avant - arrière
 Ruotare questa vite per regolare la distanza anteriore e posteriore
 Drehen Sie diese Schraube, um den vorderen und hinteren Abstand einzustellen

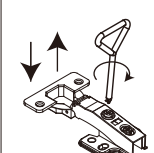

 Rotate this screw to adjust the height up and down
 Ruotare questa vite per regolare l'altezza su e giù
 Tournez cette vis pour ajuster la hauteur de haut en bas
 Girar Este tornillo para ajustar la altura hacia arriba y hacia abajo
 Drehen Sie diese Schraube, um die Höhe nach oben und unten einzustellen

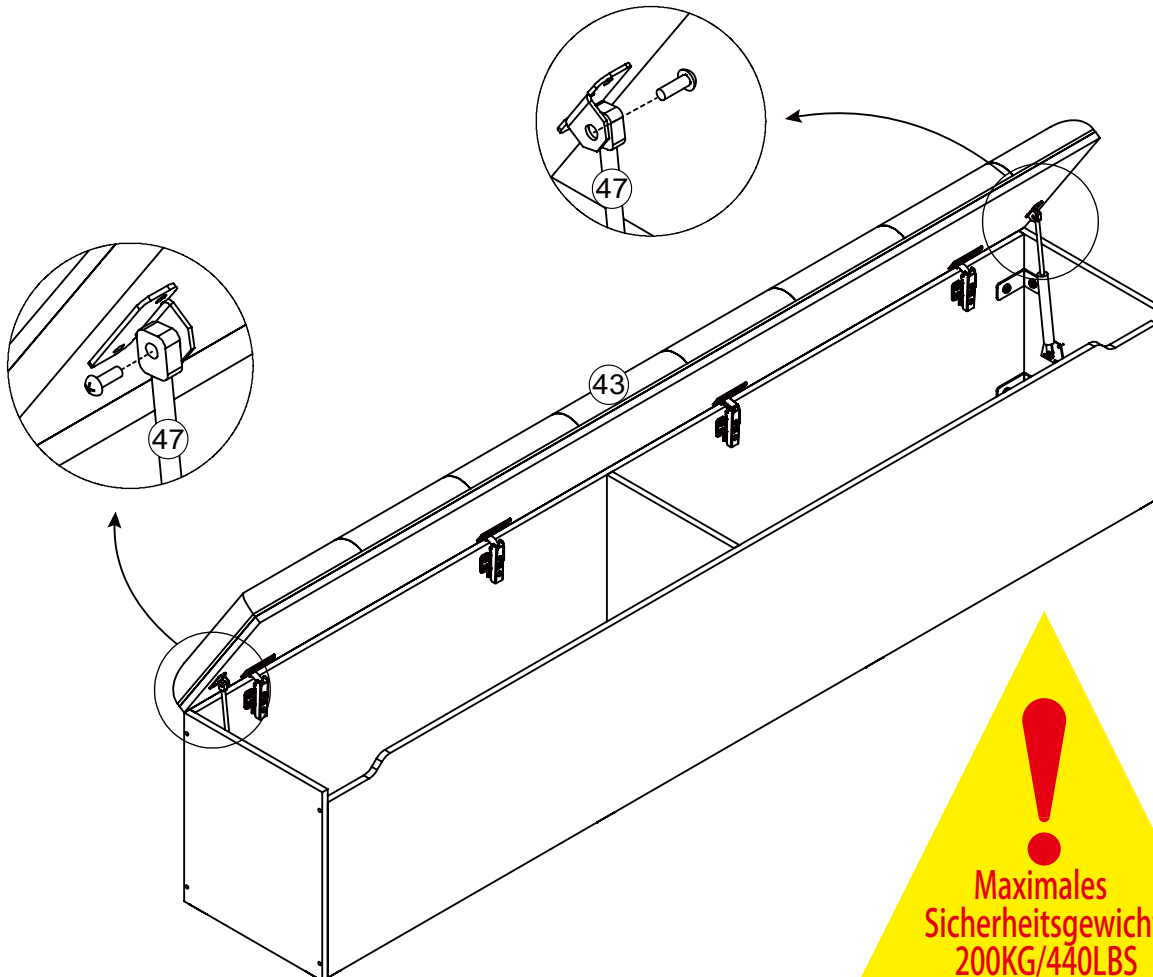
34

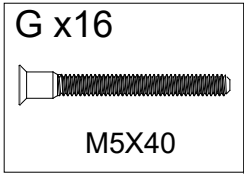
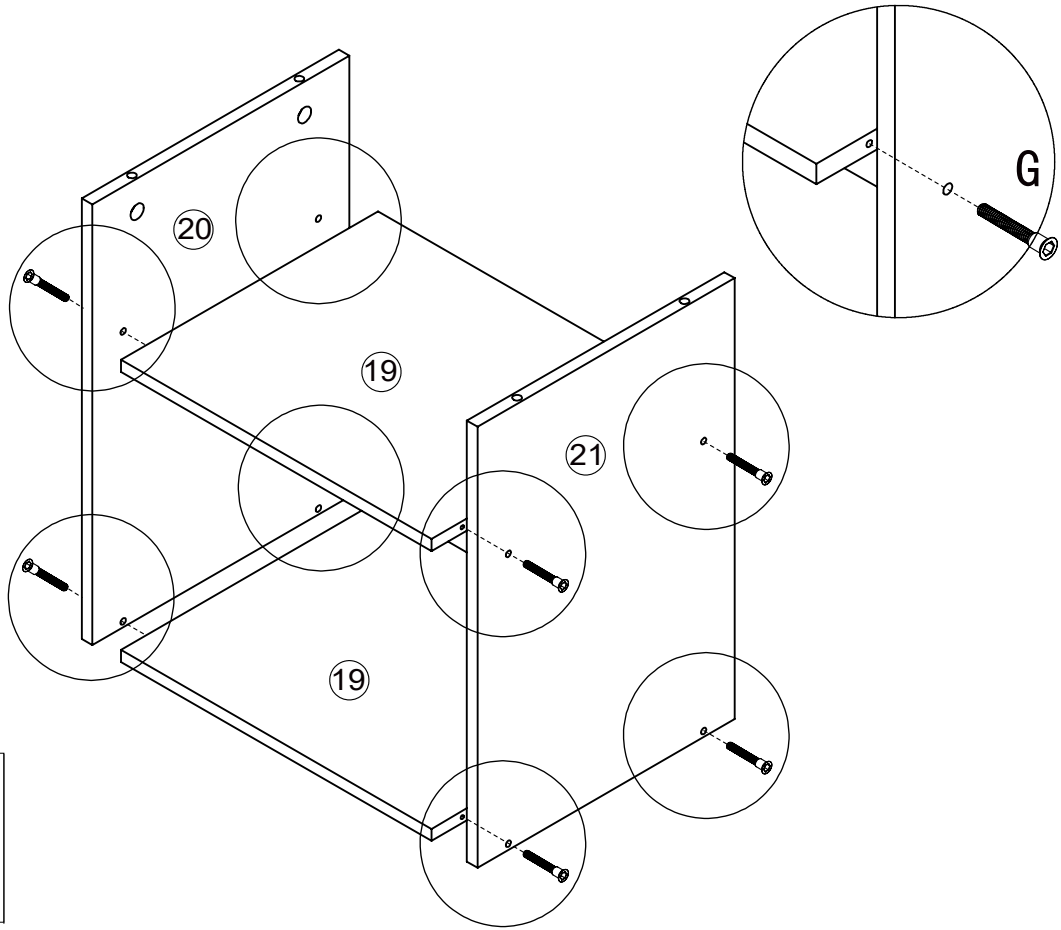

35

x2



36

x2

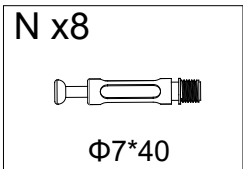
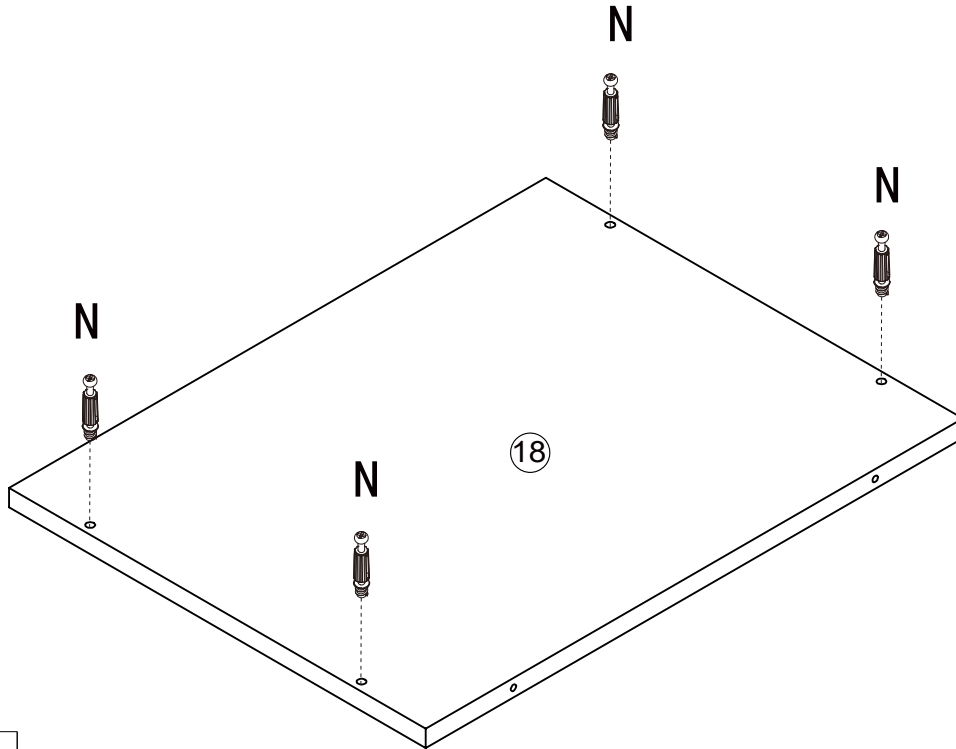

37
x2

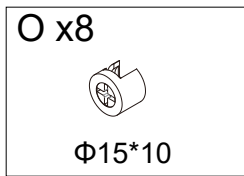
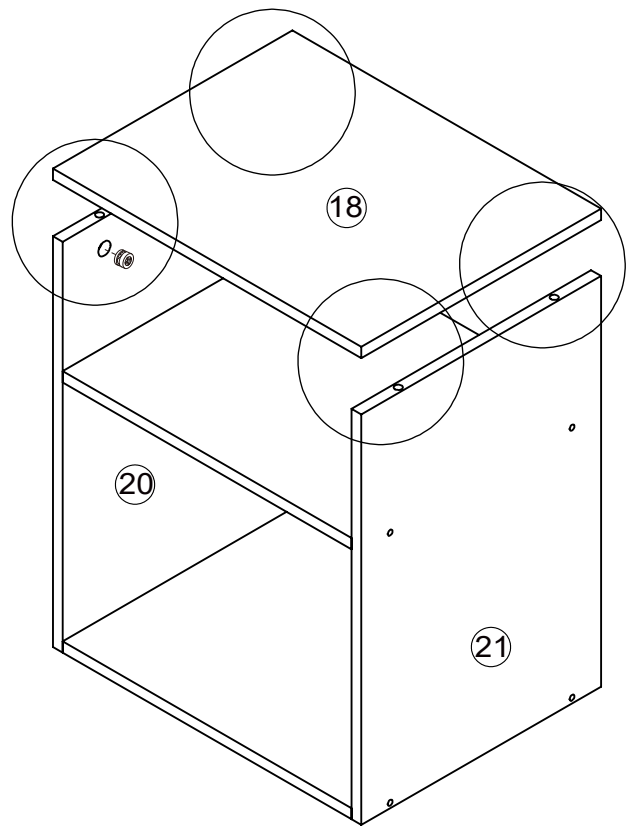
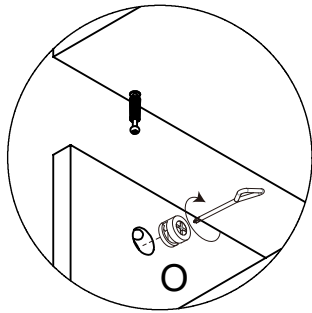

38
x2

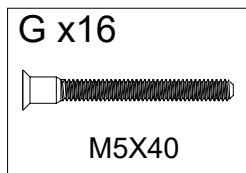
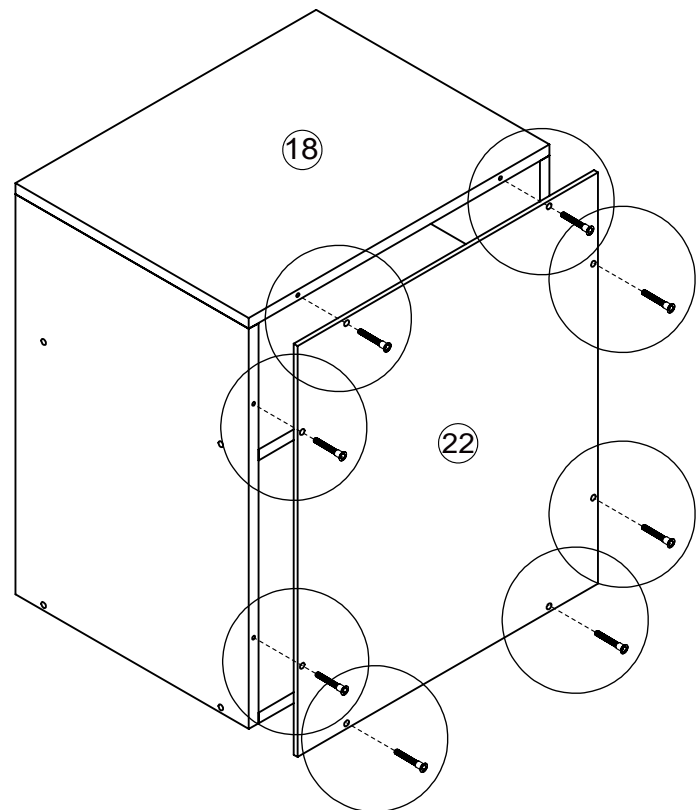
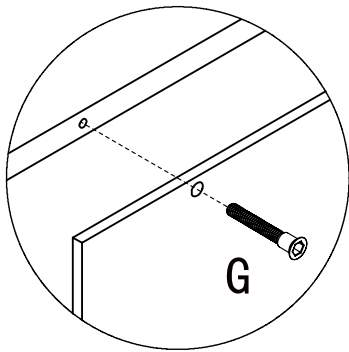

39
x2

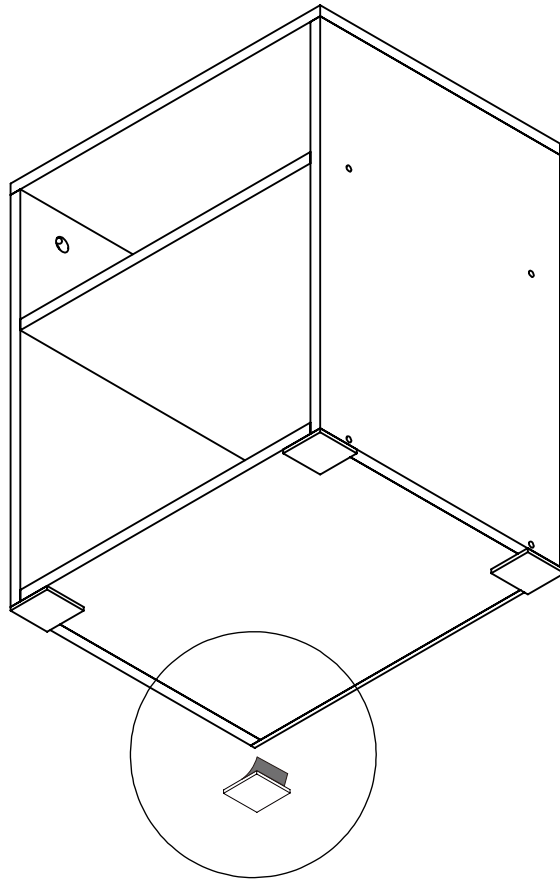
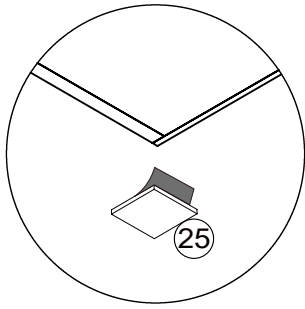

40

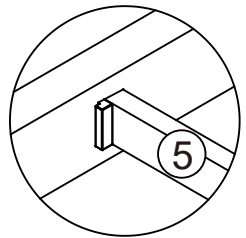
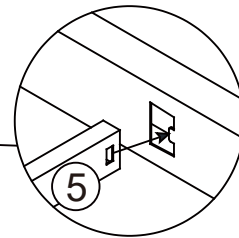
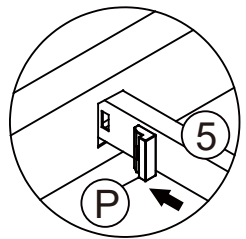
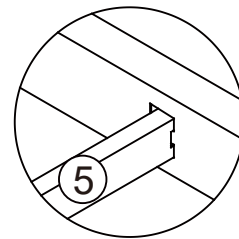
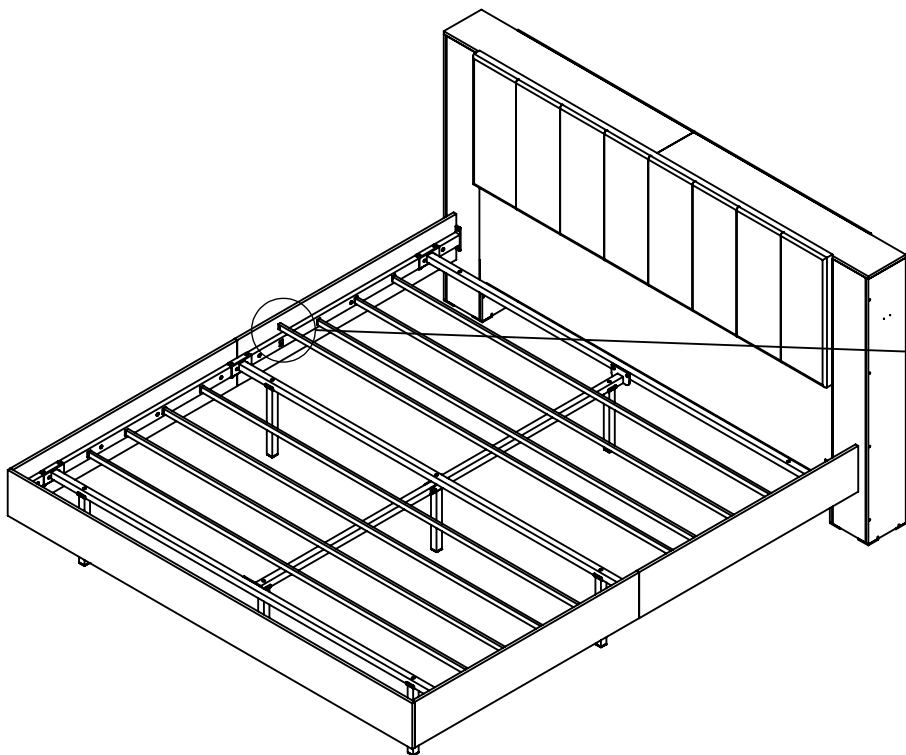

P x 16



41

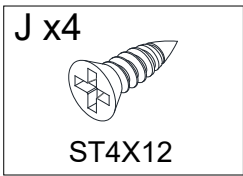
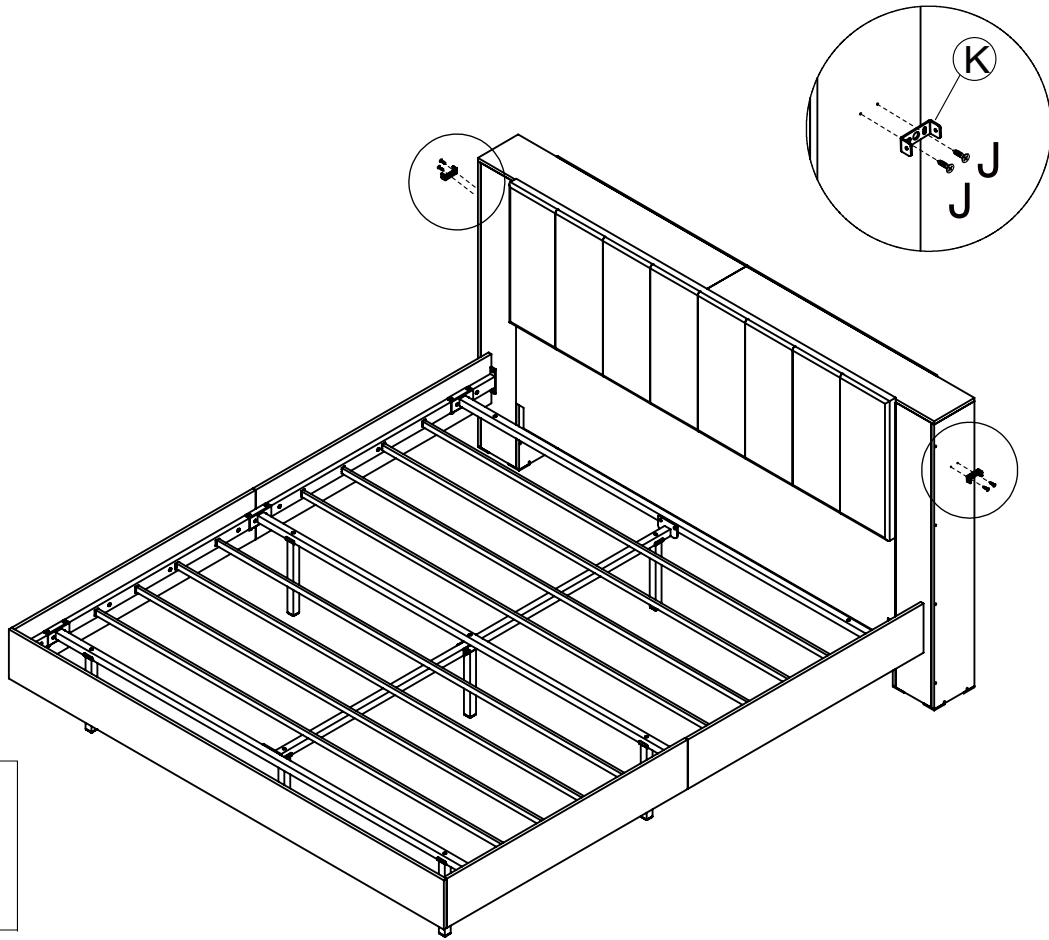

42

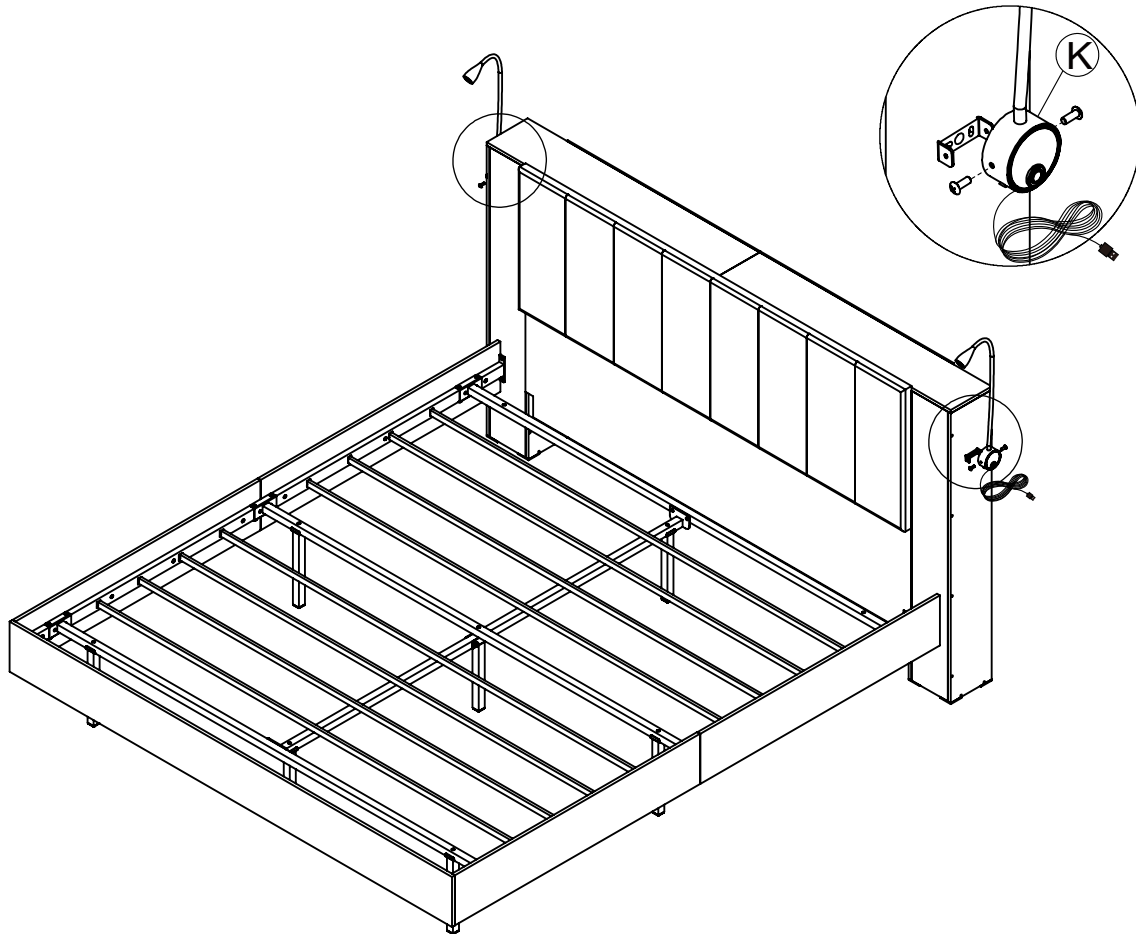



GB: Tighten all hardware
 DE: Ziehen Sie alle Beschläge fest
 FR: Serrez toutes les ferrures
 IT: Stringere tutta la ferramenta
 ES: Apriete toda la tornillería

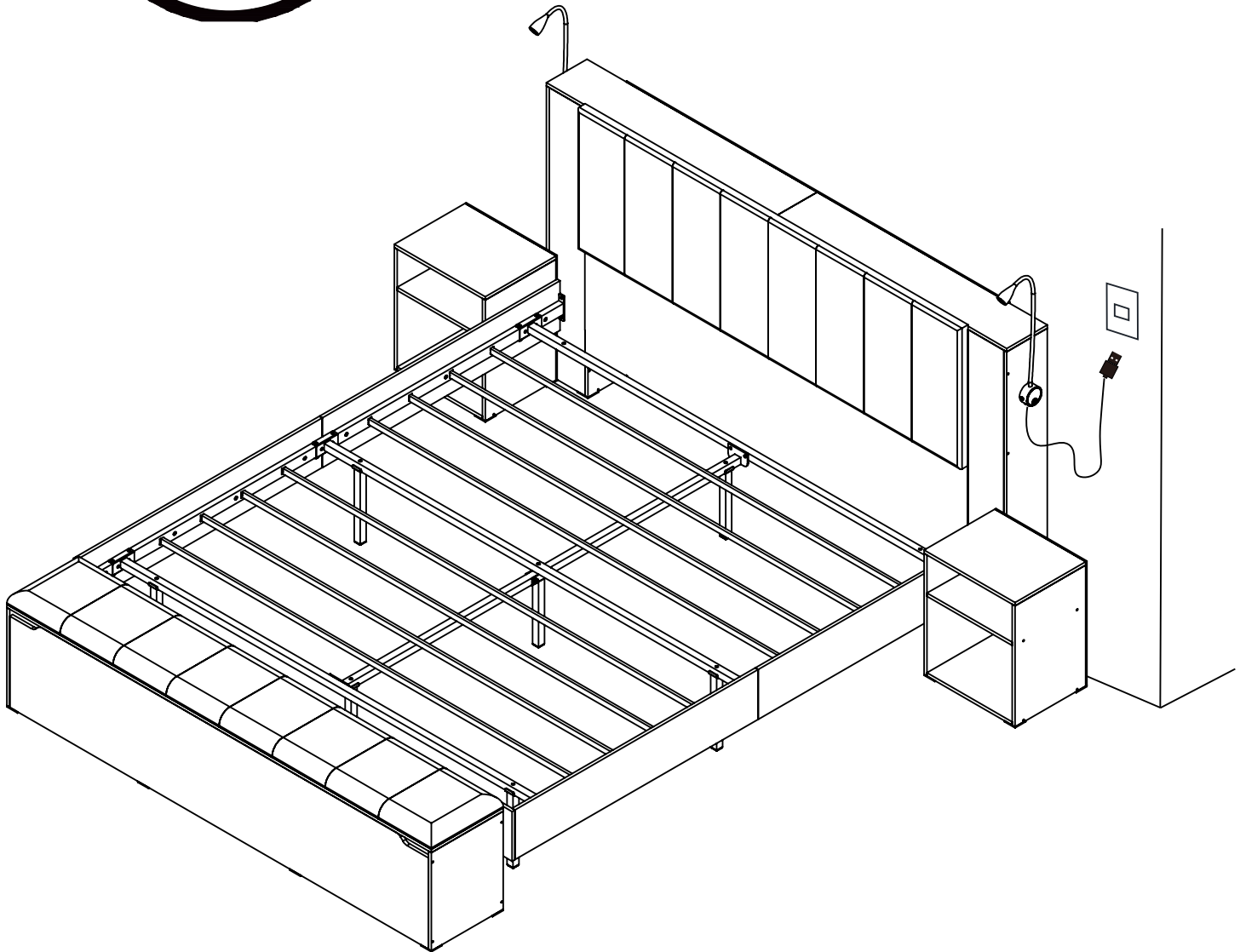

GB: Power adapter not included
 DE: Netzadapter nicht enthalten
 FR: Adaptateur secteur non inclus
 IT: Alimentatore non incluso
 ES: Adaptador de corriente no incluid

Installation Complete