













<p>Ax2</p> 	<p>Bx2</p> 	<p>Cx2</p> 	<p>Dx2</p> 
<p>Ex2</p> 	<p>Fx6</p>  <p>M4x <math>\frac{35}{1.4}</math></p>	<p>Gx4</p>  <p>M5x <math>\frac{25}{1.0}</math></p>	<p>Hx4</p> 
<p>Ix4</p> 	<p>Jx1</p> 	<p>Kx10</p> 	



3

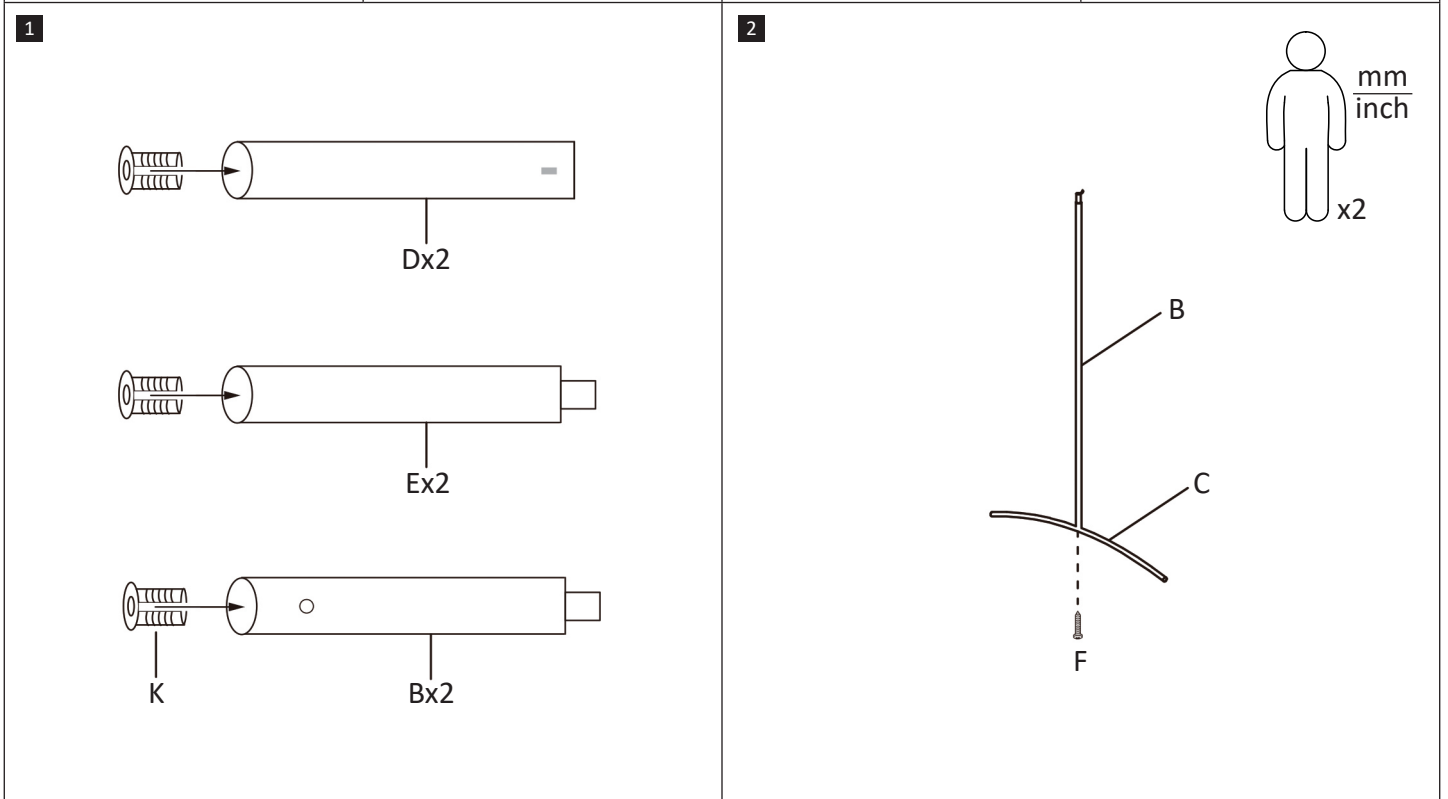
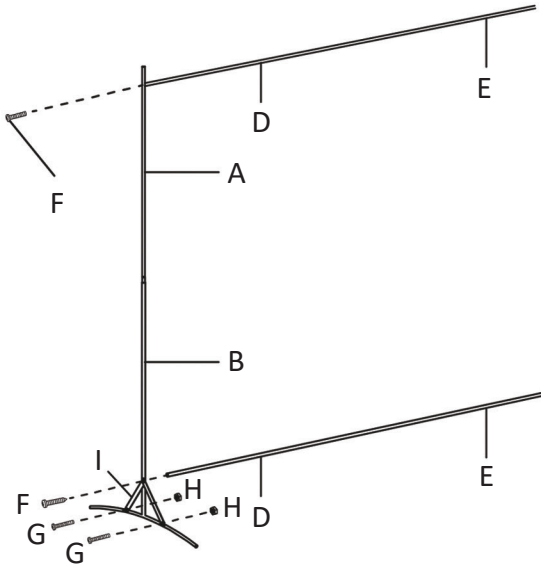

4

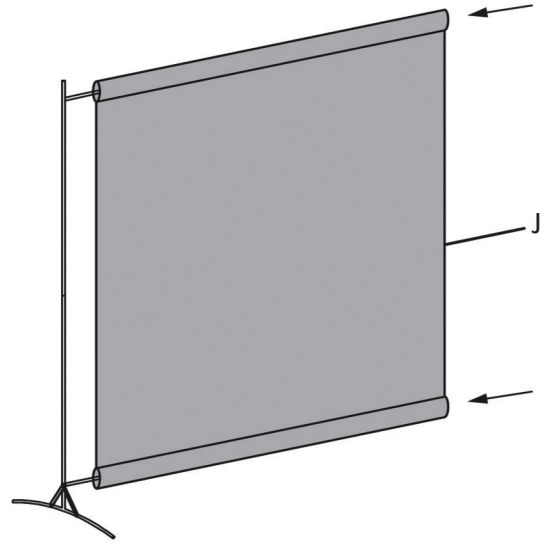

5

