













CARE AND MAINTENANCE

Spot clean using a mild water-free solvent. Only a professional cleaner should undertake a complete overall cleaning.
The use of steam or water-based cleaners may cause excessive shrinking or staining.

NOTICE

- * Please make sure that you have all parts indicated before you begin assembly of this item
- * This item should be assembled on a soft surface to prevent scratching the finish during assembly
- * This item may require periodic tightening

Part List and Hardware List

PIECE	DESCRIPTION	PICTURE	QUANTITY
A	Backrest		1X
B	Chair Leg		4X
C	Footrest		1X
D	Apron with swivel plate		1X
E	Cushion seat		1X
1	Allen Bolts M6×25mm		4X
2	Allen Bolts M6×40mm		8X
3	Allen Bolts M6×45mm		6X
4	Spring Washer M6×10mm		22X
5	Flat Washer M6×16mm		10X
6	Flat Washer M6×13mm		16X
7	Allen Key Small M4		1X
8	Allen Bolts M6×35mm		8X

Product Dimensions: 18.25"W x 19 "D x 43 "H

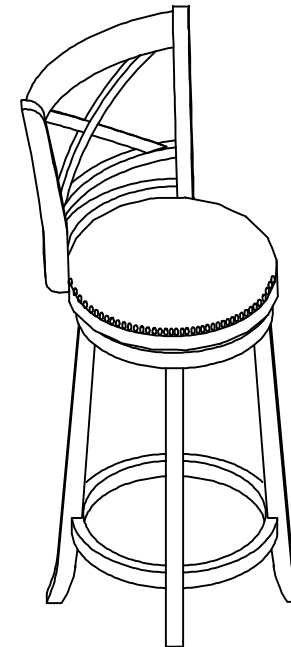

PREPARATION

Before beginning assembly of product make sure all parts are present. Compare parts with package contents list and hardware contents list.

If any part is missing or damaged, do not attempt to assemble the product.

Estimated Assembly Time: 10 minutes.

Tools Required for Assembly (included): Allen Key

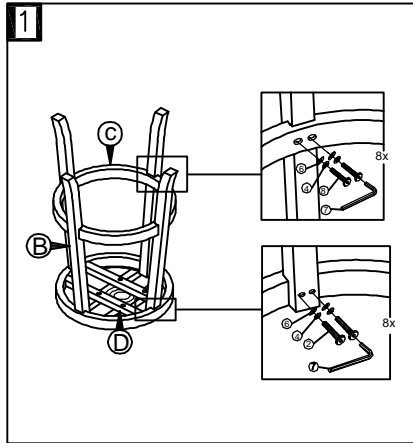

Step 1

Begin assembly by attaching the Legs (B) to the Footrest (C) by using 2 Allen Bolt (2), 2 Spring Washer (4) and 2 Flat Washer (6) per leg.

Attach the Legs (B) to the Apron with Swivel Plate (D) by using 2 Allen Bolts (2), 2 Spring Washers (4) and 2 Flat Washers (6) per leg.

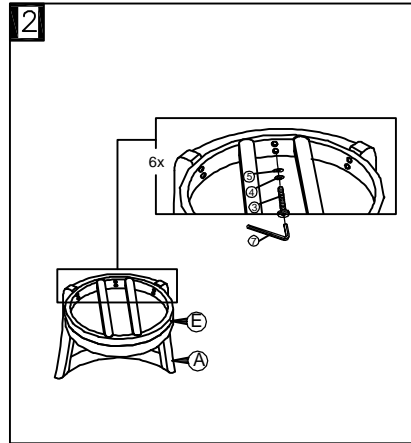

Step 2

Next attach the Backrest (A) to the Seat (E) with 6 Allen Bolts (3), 6 Spring Washers (4) and 6 Flat Washers (5).

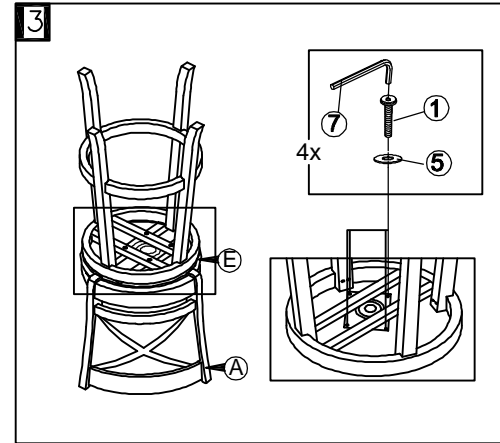

Step 3

Attach the Apron with Swivel Plate (D) to the Seat (E) by using 4 Allen Bolts (1) and 4 Flat Washers (5).

Tighten all screws with the Allen Wrench (G) provided. The assembly is now complete.